

TC74HC4514AP

4 - TO - 16 LINE DECODER / LATCH

The TC74HC4514A are high speed CMOS 4 - LINE TO 16 - LINE DECODER WITH LATCHED INPUTs fabricated with silicon gate C²MOS technology.

It achieves the high speed operation similar to equivalent LSTTL while maintaining the CMOS low power dissipation.

The selected output is enabled by a low on the inhibit input (INHIBIT). A binary code stored in the four input latches (A thru D) is decided and provides a high level at the corresponding one of sixteen outputs. When the INHIBIT is held low, all outputs are kept low however, the latch function is available.

The data applied to the data inputs are transferred to the outputs of latches when the strobe input is held high. When the strobe input is taken low, the data is retained at the output of the latches.

All inputs are equipped with protection circuits against static discharge or transient excess voltage.

FEATURES :

- High Speed..... $t_{pd} = 18ns$ (typ.) at $V_{CC} = 5V$
- Low Power Dissipation..... $I_{CC} = 4\mu A$ (Max.) at $T_a = 25^\circ C$
- High Noise Immunity..... $V_{NIH} = V_{NIL} = 28\% V_{CC}$ (Min.)
- Output Drive Capability..... 10 LSTTL Loads
- Symmetrical Output Impedance... $|I_{OH}| = I_{OL} = 4mA$ (Min.)
- Balanced Propagation Delays..... $t_{pLH} \approx t_{pHL}$
- Wide Operating Voltage Range... V_{CC} (opr.) = 2V~6V
- Pin and Function Compatible with 4514B

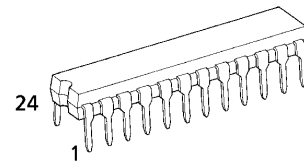

P (DIP24-P-300-2.54)
Weight : 1.50g (Typ.)

PIN ASSIGNMENT

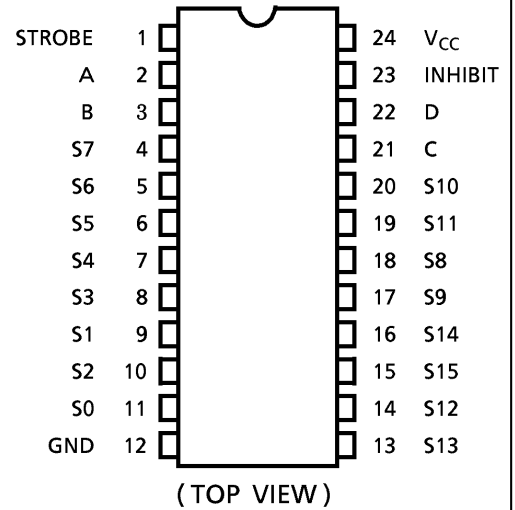

IEC LOGIC SYMBOL

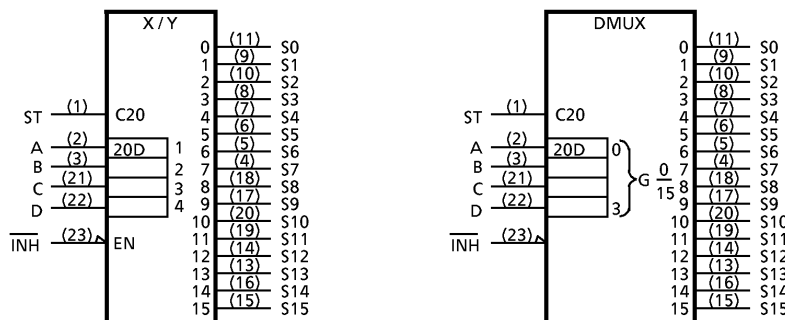

TRUTH TABLE

INPUTS					SELECTED OUTPUT
INHIBIT	A	B	C	D	"H"
L	L	L	L	L	S0
L	H	L	L	L	S1
L	L	H	L	L	S2
L	H	H	L	L	S3
L	L	L	H	L	S4
L	H	L	H	L	S5
L	L	H	H	L	S6
L	H	H	H	L	S7
L	L	L	L	H	S8
L	H	L	L	H	S9
L	L	H	L	H	S10
L	H	H	L	H	S11
L	L	L	H	H	S12
L	H	L	H	H	S13
L	L	H	H	H	S14
L	H	H	H	H	S15
H	X	X	X	X	ALL OUTPUT "L"

- X : Don't Care
- STROBE = "H"; REFER TO TRUTH TABLE
- STROBE = "L"

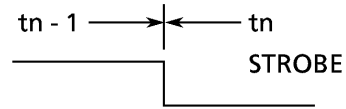

Data at the negative going transition of strobe shall be provided on each output while strobe is held low.

SYSTEM DIAGRAM

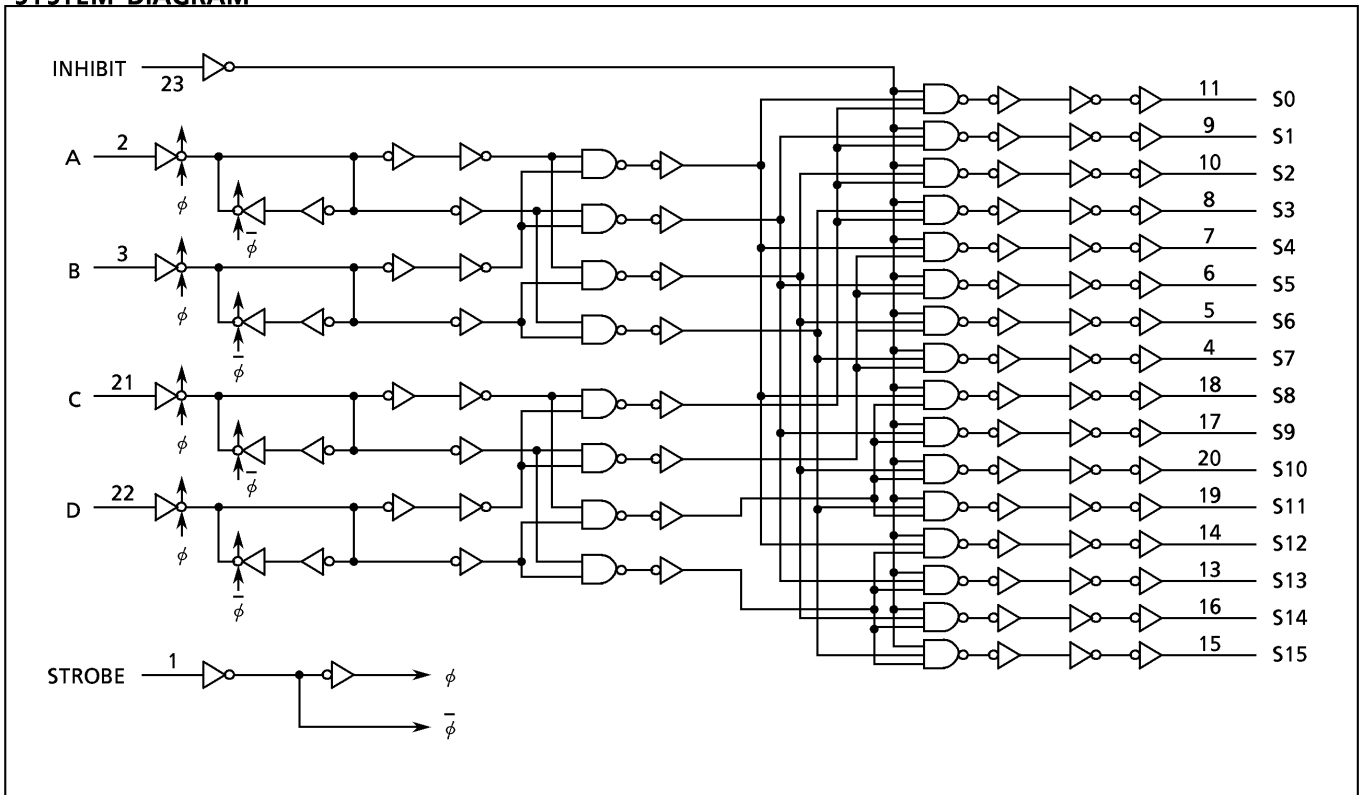

ABSOLUTE MAXIMUM RATINGS

PARAMETER	SYMBOL	VALUE	UNIT
Supply Voltage Range	V_{CC}	-0.5~7	V
DC Input Voltage	V_{IN}	-0.5~ $V_{CC}+0.5$	V
DC Output Voltage	V_{OUT}	-0.5~ $V_{CC}+0.5$	V
Input Diode Current	I_{IK}	± 20	mA
Output Diode Current	I_{OK}	± 20	mA
DC Output Current	I_{OUT}	± 25	mA
DC V_{CC} /Ground Current	I_{CC}	± 50	mA
Power Dissipation	P_D	500 (DIP)*	mW
Storage Temperature	T_{stg}	-65~150	°C

*500mW in the range of $T_a = -40^{\circ}\text{C} \sim 65^{\circ}\text{C}$. From $T_a = 65^{\circ}\text{C}$ to 85°C a derating factor of $-10\text{mW}/^{\circ}\text{C}$ shall be applied until 300mW.

RECOMMENDED OPERATING CONDITIONS

PARAMETER	SYMBOL	VALUE	UNIT
Supply Voltage	V_{CC}	2~6	V
Input Voltage	V_{IN}	0~ V_{CC}	V
Output Voltage	V_{OUT}	0~ V_{CC}	V
Operating Temperature	T_{opr}	-40~85	°C
Input Rise and Fall Time	t_r, t_f	0~1000 ($V_{CC} = 2.0\text{V}$) 0~500 ($V_{CC} = 4.5\text{V}$) 0~400 ($V_{CC} = 6.0\text{V}$)	ns

DC ELECTRICAL CHARACTERISTICS

PARAMETER	SYMBOL	TEST CONDITION	V_{CC} (V)	$T_a = 25^{\circ}\text{C}$			$T_a = -40 \sim 85^{\circ}\text{C}$		UNIT	
				MIN.	TYP.	MAX.	MIN.	MAX.		
High - Level Input Voltage	V_{IH}		2.0	1.50	—	—	1.50	—	V	
			4.5	3.15	—	—	3.15	—		
			6.0	4.20	—	—	4.20	—		
Low - Level Input Voltage	V_{IL}		2.0	—	—	0.50	—	0.50	V	
			4.5	—	—	1.35	—	1.35		
			6.0	—	—	1.80	—	1.80		
High - Level Output Voltage	V_{OH}	$V_{IN} = V_{IH}$ or V_{IL}	$I_{OH} = -20\mu\text{A}$	2.0	1.9	2.0	—	1.9	—	V
				4.5	4.4	4.5	—	4.4	—	
			$I_{OH} = -4\text{ mA}$ $I_{OH} = -5.2\text{ mA}$	4.5	4.18	4.31	—	4.13	—	
				6.0	5.68	5.80	—	5.63	—	
Low - Level Output Voltage	V_{OL}	$V_{IN} = V_{IH}$ or V_{IL}	$I_{OL} = 20\mu\text{A}$	2.0	—	0.0	0.1	—	0.1	V
				4.5	—	0.0	0.1	—	0.1	
			$I_{OL} = 4\text{ mA}$ $I_{OL} = 5.2\text{ mA}$	4.5	—	0.17	0.26	—	0.33	
				6.0	—	0.18	0.26	—	0.33	
Input Leakage Current	I_{IN}	$V_{IN} = V_{CC}$ or GND	6.0	—	—	± 0.1	—	± 1.0	μA	
Quiescent Supply Current	I_{CC}	$V_{IN} = V_{CC}$ or GND	6.0	—	—	4.0	—	40.0		

TIMING REQUIREMENTS (Input $t_r = t_f = 6ns$)

PARAMETER	SYMBOL	TEST CONDITION	Ta = 25°C			Ta = -40-85°C	UNIT
			V _{CC} (V)	TYP.	LIMIT	LIMIT	
Minimum Pulse Width (STROBE)	$t_{W(H)}$		2.0	—	75	95	ns
			4.5	—	15	19	
			6.0	—	13	16	
Minimum Set-up Time (DATA)	t_s		2.0	—	50	65	
			4.5	—	10	13	
			6.0	—	9	11	
Minimum Hold Time (DATA)	t_h		2.0	—	5	5	
			4.5	—	5	5	
			6.0	—	5	5	

AC ELECTRICAL CHARACTERISTICS (C_L = 15pF, V_{CC} = 5V, Ta = 25°C, Input $t_r = t_f = 6ns$)

PARAMETER	SYMBOL	TEST CONDITION	MIN.	TYP.	MAX.	UNIT
Output Transition Time	t_{TLH} t_{THL}		—	4	8	ns
Propagation Delay Time (DATA—Sn)	t_{pLH} t_{pHL}		—	18	30	
Propagation Delay Time (STROBE—Sn)	t_{pLH} t_{pHL}		—	20	30	
Propagation Delay Time (INHIBIT—Sn)	t_{pLH} t_{pHL}		—	16	30	

AC ELECTRICAL CHARACTERISTICS (C_L = 50pF, Input $t_r = t_f = 6ns$)

PARAMETER	SYMBOL	TEST CONDITION	Ta = 25°C			Ta = -40-85°C		UNIT	
			V _{CC} (V)	MIN.	TYP.	MAX.	MIN.		MAX.
Output Transition Time	t_{TLH} t_{THL}		2.0	—	30	75	—	95	ns
			4.5	—	8	15	—	19	
			6.0	—	7	13	—	16	
Propagation Delay Time (DATA—Sn)	t_{pLH} t_{pHL}		2.0	—	65	175	—	220	
			4.5	—	22	35	—	44	
			6.0	—	19	30	—	37	
Propagation Delay Time (STROBE—Sn)	t_{pLH} t_{pHL}		2.0	—	75	175	—	220	
			4.5	—	24	35	—	44	
			6.0	—	20	30	—	37	
Propagation Delay Time (INHIBIT—Sn)	t_{pLH} t_{pHL}		2.0	—	60	175	—	220	
			4.5	—	20	35	—	44	
			6.0	—	17	30	—	37	
Input Capacitance	C _{IN}		—	5	10	—	10	pF	
Power Dissipation Capacitance	C _{PD} (1)		—	61	—	—	—		

Note (1) C_{PD} is defined as the value of the internal equivalent capacitance which is calculated from the operating current consumption without load.

Average operating current can be obtained by the equation :

$$I_{CC}(\text{opr}) = C_{PD} \cdot V_{CC} \cdot f_{IN} + I_{CC}$$

DIP 24PIN PACKAGE DIMENSIONS (DIP24-P-300-2.54)

Unit in mm

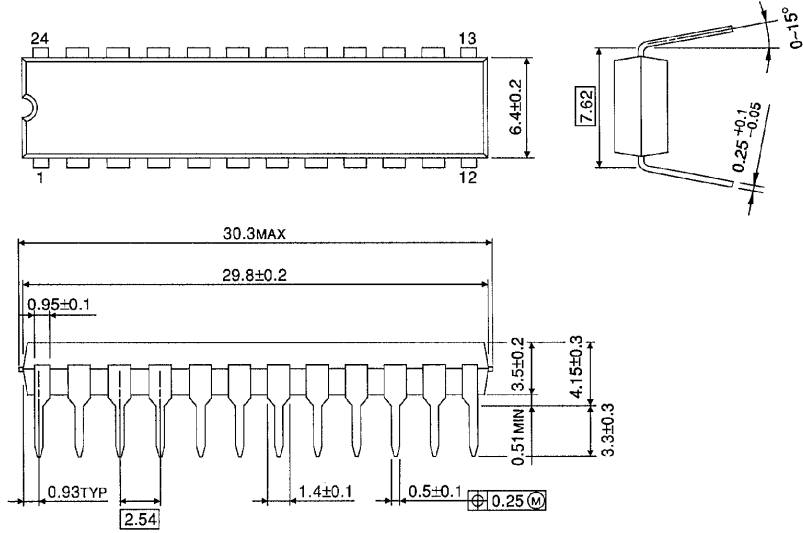

Weight : 1.50g (Typ.)

RESTRICTIONS ON PRODUCT USE

000707EBA

- TOSHIBA is continually working to improve the quality and reliability of its products. Nevertheless, semiconductor devices in general can malfunction or fail due to their inherent electrical sensitivity and vulnerability to physical stress. It is the responsibility of the buyer, when utilizing TOSHIBA products, to comply with the standards of safety in making a safe design for the entire system, and to avoid situations in which a malfunction or failure of such TOSHIBA products could cause loss of human life, bodily injury or damage to property. In developing your designs, please ensure that TOSHIBA products are used within specified operating ranges as set forth in the most recent TOSHIBA products specifications. Also, please keep in mind the precautions and conditions set forth in the "Handling Guide for Semiconductor Devices," or "TOSHIBA Semiconductor Reliability Handbook" etc..
- The TOSHIBA products listed in this document are intended for usage in general electronics applications (computer, personal equipment, office equipment, measuring equipment, industrial robotics, domestic appliances, etc.). These TOSHIBA products are neither intended nor warranted for usage in equipment that requires extraordinarily high quality and/or reliability or a malfunction or failure of which may cause loss of human life or bodily injury ("Unintended Usage"). Unintended Usage include atomic energy control instruments, airplane or spaceship instruments, transportation instruments, traffic signal instruments, combustion control instruments, medical instruments, all types of safety devices, etc.. Unintended Usage of TOSHIBA products listed in this document shall be made at the customer's own risk.
- The products described in this document are subject to the foreign exchange and foreign trade laws.
- The information contained herein is presented only as a guide for the applications of our products. No responsibility is assumed by TOSHIBA CORPORATION for any infringements of intellectual property or other rights of the third parties which may result from its use. No license is granted by implication or otherwise under any intellectual property or other rights of TOSHIBA CORPORATION or others.
- The information contained herein is subject to change without notice.