

TOSHIBA CMOS Digital Integrated Circuit Silicon Monolithic

TC74LCX16244AFT

Low-Voltage 16-Bit Bus Buffer with 5-V Tolerant Inputs and Outputs

The TC74LCX16244AFT is a high-performance CMOS 16-bit bus buffer. Designed for use in 3.3-V systems, it achieves high-speed operation while maintaining the CMOS low power dissipation.

The device is designed for low-voltage (3.3 V) VCC applications, but it could be used to interface to 5 V supply environment for both inputs and outputs.

This device is non-inverting 3-state buffer having four active-low output enables. It can be used as four 4-bit buffers two 8-bit buffers or one 16-bit buffer. When the OE input is high, the outputs are in a high-impedance state. This device is designed to be used with 3-state memory address drivers, etc.

All inputs are equipped with protection circuits against static discharge.

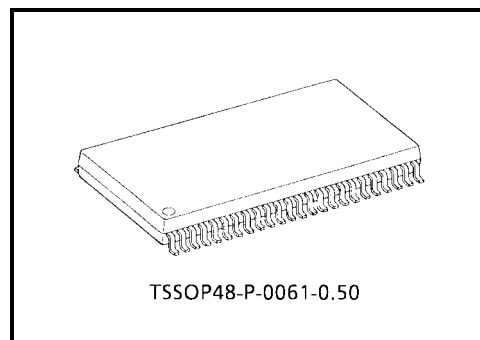

Weight: 0.25 g (typ.)

Features

- Low-voltage operation: $V_{CC} = 2.0$ to 3.6 V
- High-speed operation: $t_{pd} = 5.2$ ns (max) ($V_{CC} = 3.0$ to 3.6 V)
- Output current: $|I_{OH}|/I_{OL} = 24$ mA (min) ($V_{CC} = 3.0$ V)
- Latch-up performance: ± 500 mA
- Package: TSSOP (thin shrink small outline package)
- Power-down protection provided on all inputs and outputs

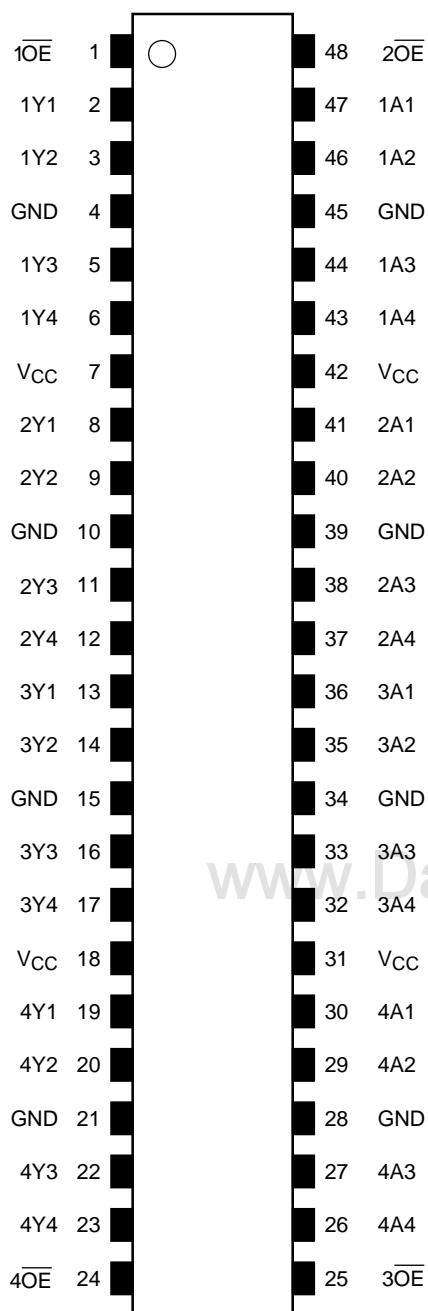
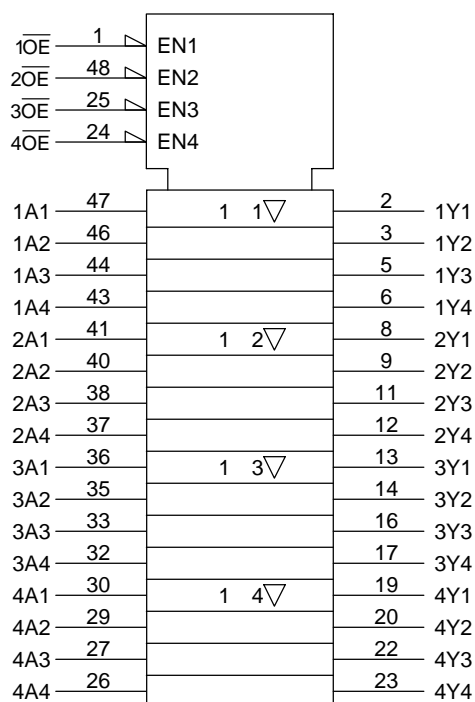
Pin Assignment (top view)**IEC Logic Symbol**

www.DataSheet4U.com

Truth Table

Inputs		Outputs
$\overline{1OE}$	1A1-1A4	1Y1-1Y4
L	L	L
L	H	H
H	X	Z

Inputs		Outputs
$\overline{2OE}$	2A1-2A4	2Y1-2Y4
L	L	L
L	H	H
H	X	Z

Inputs		Outputs
$\overline{3OE}$	3A1-3A4	3Y1-3Y4
L	L	L
L	H	H
H	X	Z

Inputs		Outputs
$\overline{4OE}$	4A1-4A4	4Y1-4Y4
L	L	L
L	H	H
H	X	Z

X: Don't care

Z: High impedance

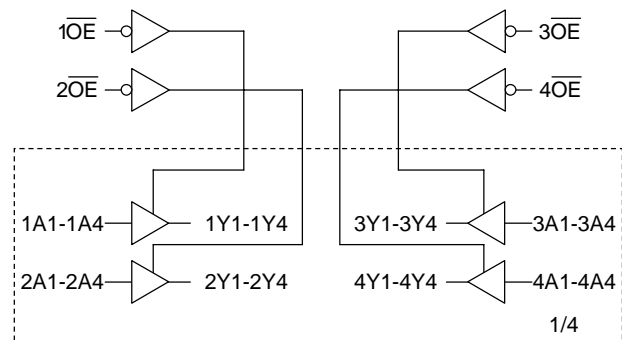
System Diagram

www.DataSheet4U.com

Maximum Ratings

Characteristics	Symbol	Rating	Unit
Power supply voltage	V_{CC}	-0.5 to 7.0	V
Input voltage	V_{IN}	-0.5 to 7.0	V
Output voltage	V_{OUT}	-0.5 to 7.0 (Note 1)	V
		-0.5 to $V_{CC} + 0.5$ (Note 2)	
Input diode current	I_{IK}	-50	mA
Output diode current	I_{OK}	± 50 (Note 3)	mA
DC output current	I_{OUT}	± 50	mA
Power dissipation	P_D	400	mW
DC V_{CC} /ground current per supply pin	I_{CC}/I_{GND}	± 100	mA
Storage temperature	T_{stg}	-65 to 150	$^{\circ}C$

Note 1: Output in OFF state

Note 2: High or low state. I_{OUT} absolute maximum rating must be observed.

Note 3: $V_{OUT} < GND$, $V_{OUT} > V_{CC}$

Recommended Operating Conditions

Characteristics	Symbol	Rating	Unit
Power supply voltage	V_{CC}	2.0 to 3.6	V
		1.5 to 3.6 (Note 4)	
Input voltage	V_{IN}	0 to 5.5	V
Output voltage	V_{OUT}	0 to 5.5 (Note 5)	V
		0 to V_{CC} (Note 6)	
Output current	I_{OH}/I_{OL}	± 24 (Note 7)	mA
		± 12 (Note 8)	
Operating temperature	T_{opr}	-40 to 85	$^{\circ}C$
Input rise and fall time	dt/dv	0 to 10 (Note 9)	ns/V

Note 4: Data retention only

Note 5: Output in OFF state

Note 6: High or low state

Note 7: $V_{CC} = 3.0$ to 3.6 V

Note 8: $V_{CC} = 2.7$ to 3.0 V

Note 9: $V_{IN} = 0.8$ to 2.0 V, $V_{CC} = 3.0$ V

Electrical Characteristics

DC Characteristics (Ta = -40 to 85°C)

Characteristics		Symbol	Test Condition		V _{CC} (V)	Min	Max	Unit
Input voltage	H-level	V _{IH}	—		2.7 to 3.6	2.0	—	V
	L-level	V _{IL}	—		2.7 to 3.6	—	0.8	
Output voltage	H-level	V _{OH}	V _{IN} = V _{IH} or V _{IL}	I _{OH} = -100 μA	2.7 to 3.6	V _{CC} - 0.2	—	V
				I _{OH} = -12 mA	2.7	2.2	—	
				I _{OH} = -18 mA	3.0	2.4	—	
				I _{OH} = -24 mA	3.0	2.2	—	
	L-level	V _{OL}	V _{IN} = V _{IH} or V _{IL}	I _{OL} = 100 μA	2.7 to 3.6	—	0.2	
				I _{OL} = 12 mA	2.7	—	0.4	
				I _{OL} = 16 mA	3.0	—	0.4	
				I _{OL} = 24 mA	3.0	—	0.55	
Input leakage current		I _{IN}	V _{IN} = 0 to 5.5 V		2.7 to 3.6	—	±5.0	μA
3-state output off-state current		I _{OZ}	V _{IN} = V _{IH} or V _{IL} V _{OUT} = 0 to 5.5 V		2.7 to 3.6	—	±5.0	μA
Power off leakage current		I _{OFF}	V _{IN} /V _{OUT} = 5.5 V		0	—	10.0	μA
Quiescent supply current		I _{CC}	V _{IN} = V _{CC} or GND		2.7 to 3.6	—	20.0	μA
			V _{IN} /V _{OUT} = 3.6 to 5.5 V		2.7 to 3.6	—	±20.0	
Increase in I _{CC} per input		ΔI _{CC}	V _{IH} = V _{CC} - 0.6 V		2.7 to 3.6	—	500	

AC Characteristics (Ta = -40 to 85°C)

Characteristics		Symbol	Test Condition		V _{CC} (V)	Min	Max	Unit
Propagation delay time	t _{pLH}	t _{pHL}	Figure 1, Figure 2		2.7	—	6.2	ns
					3.3 ± 0.3	1.5	5.2	
3-state output enable time	t _{pZL}	t _{pZH}	Figure 1, Figure 3		2.7	—	7.5	ns
					3.3 ± 0.3	1.5	6.5	
3-state output disable time	t _{pLZ}	t _{pHZ}	Figure 1, Figure 3		2.7	—	6.5	ns
					3.3 ± 0.3	1.5	5.5	
Output to output skew	t _{osLH}	t _{osHL}	(Note 10)		2.7	—	—	ns
					3.3 ± 0.3	—	1.0	

Note 10: Parameter guaranteed by design.

$$(t_{osLH} = |t_{pLHm} - t_{pLHn}|, t_{osHL} = |t_{pHLm} - t_{pHLn}|)$$

Dynamic Switching Characteristics

($T_a = 25^\circ\text{C}$, input: $t_r = t_f = 2.5 \text{ ns}$, $C_L = 50 \text{ pF}$, $R_L = 500 \Omega$)

Characteristics	Symbol	Test Condition	V_{CC} (V)	Typ.	Unit	
Quiet output maximum dynamic	V_{OL}	V_{OLP}	$V_{IH} = 3.3 \text{ V}, V_{IL} = 0 \text{ V}$	3.3	0.8	V
Quiet output minimum dynamic	V_{OL}	$ V_{OLV} $	$V_{IH} = 3.3 \text{ V}, V_{IL} = 0 \text{ V}$	3.3	0.8	V

Capacitive Characteristics ($T_a = 25^\circ\text{C}$)

Characteristics	Symbol	Test Condition	V_{CC} (V)	Typ.	Unit
Input capacitance	C_{IN}	—	3.3	7	pF
Output capacitance	C_{OUT}	—	3.3	8	pF
Power dissipation capacitance	C_{PD}	$f_{IN} = 10 \text{ MHz}$ (Note 11)	3.3	25	pF

Note 11: C_{PD} is defined as the value of the internal equivalent capacitance which is calculated from the operating current consumption without load.

Average operating current can be obtained by the equation:

$$I_{CC(\text{opr})} = C_{PD} \cdot V_{CC} \cdot f_{IN} + I_{CC}/16 \text{ (per bit)}$$

AC Test Circuit

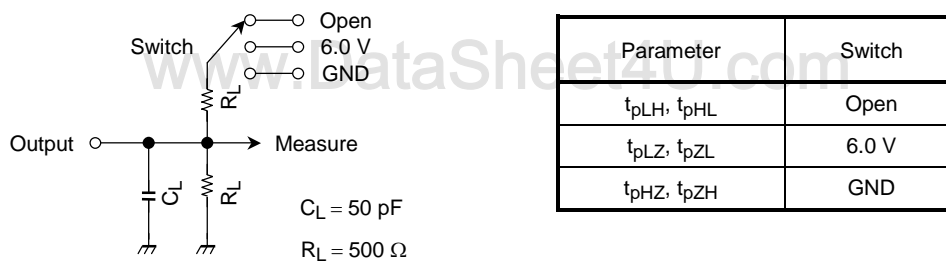

Figure 1

AC Waveform

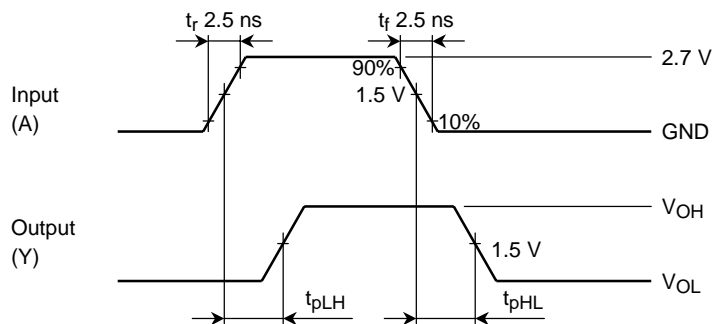

Figure 2 t_{pLH}, t_{pHL}

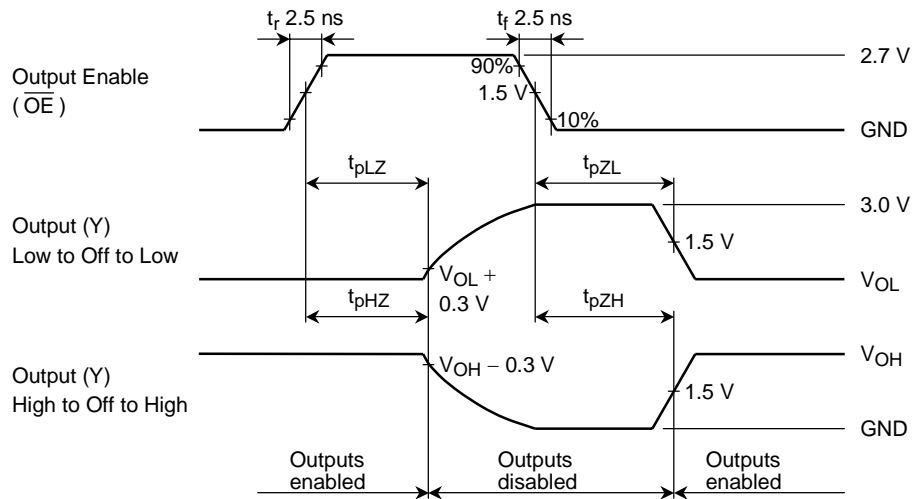

Figure 3 t_{pLZ} , t_{pHZ} , t_{pZL} , t_{pZH}

www.DataSheet4U.com

Package Dimensions

TSSOP48-P-0061-0.50

Unit : mm

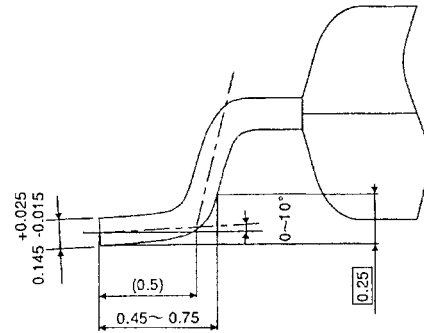
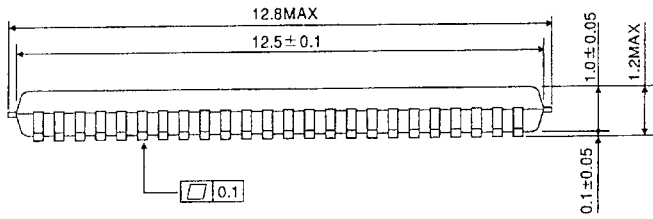
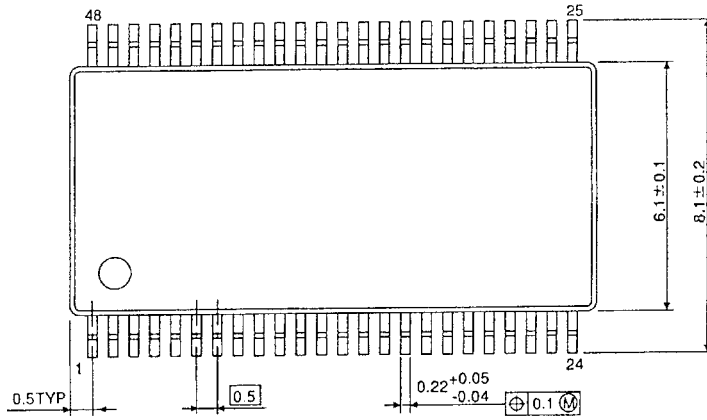

Weight: 0.25 g (typ.)

www.DataSheet4U.com

RESTRICTIONS ON PRODUCT USE

000707EBA

- TOSHIBA is continually working to improve the quality and reliability of its products. Nevertheless, semiconductor devices in general can malfunction or fail due to their inherent electrical sensitivity and vulnerability to physical stress. It is the responsibility of the buyer, when utilizing TOSHIBA products, to comply with the standards of safety in making a safe design for the entire system, and to avoid situations in which a malfunction or failure of such TOSHIBA products could cause loss of human life, bodily injury or damage to property.
In developing your designs, please ensure that TOSHIBA products are used within specified operating ranges as set forth in the most recent TOSHIBA products specifications. Also, please keep in mind the precautions and conditions set forth in the "Handling Guide for Semiconductor Devices," or "TOSHIBA Semiconductor Reliability Handbook" etc..
- The TOSHIBA products listed in this document are intended for usage in general electronics applications (computer, personal equipment, office equipment, measuring equipment, industrial robotics, domestic appliances, etc.). These TOSHIBA products are neither intended nor warranted for usage in equipment that requires extraordinarily high quality and/or reliability or a malfunction or failure of which may cause loss of human life or bodily injury ("Unintended Usage"). Unintended Usage include atomic energy control instruments, airplane or spaceship instruments, transportation instruments, traffic signal instruments, combustion control instruments, medical instruments, all types of safety devices, etc.. Unintended Usage of TOSHIBA products listed in this document shall be made at the customer's own risk.
- The products described in this document are subject to the foreign exchange and foreign trade laws.
- The information contained herein is presented only as a guide for the applications of our products. No responsibility is assumed by TOSHIBA CORPORATION for any infringements of intellectual property or other rights of the third parties which may result from its use. No license is granted by implication or otherwise under any intellectual property or other rights of TOSHIBA CORPORATION or others.
- The information contained herein is subject to change without notice.