

TOSHIBA CMOS Digital Integrated Circuit Silicon Monolithic

## TC74VHC174F, TC74VHC174FN, TC74VHC174FT

### Hex D-Type Flip Flop with Clear

The TC74VHC174 is an advanced high speed CMOS HEX D-TYPE FLIP FLOP fabricated with silicon gate C<sup>2</sup>MOS technology.

It achieves the high speed operation similar to equivalent Bipolar Schottky TTL while maintaining the CMOS low power dissipation.

Information signals applied to D inputs are transferred to the Q output on the positive going edge of the clock pulse.

When the  $\overline{\text{CLR}}$  input is held low, the Q output are in the low logic level independent of the other inputs.

An input protection circuit ensures that 0 to 5.5 V can be applied to the input pins without regard to the supply voltage. This device can be used to interface 5 to 3 V systems and two supply systems such as battery back up. This circuit prevents device destruction due to mismatched supply and input voltages.

### Features

- High speed:  $f_{\text{max}} = 150 \text{ MHz (typ.)}$  at  $V_{\text{CC}} = 5 \text{ V}$
- Low power dissipation:  $I_{\text{CC}} = 4 \mu\text{A (max)}$  at  $T_a = 25^\circ\text{C}$
- High noise immunity:  $V_{\text{NIH}} = V_{\text{NIL}} = 28\% V_{\text{CC}}$  (min)
- Power down protection is provided on all inputs.
- Balanced propagation delays:  $t_{\text{pLH}} \approx t_{\text{pHL}}$
- Wide operating voltage range:  $V_{\text{CC (opr)}} = 2 \text{ to } 5.5 \text{ V}$
- Low noise:  $V_{\text{OLP}} = 0.8 \text{ V (max)}$
- Pin and function compatible with 74ALS174

Note: xxxFN (JEDEC SOP) is not available in Japan.

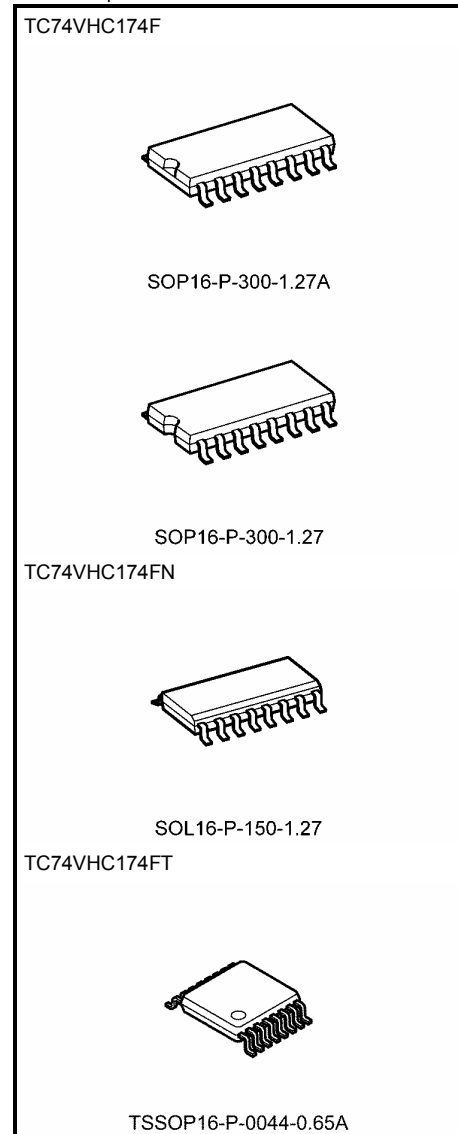

Weight	
SOP16-P-300-1.27A	: 0.18 g (typ.)
SOP16-P-300-1.27	: 0.18 g (typ.)
SOL16-P-150-1.27	: 0.13 g (typ.)
TSSOP16-P-0044-0.65A	: 0.06 g (typ.)

## Pin Assignment

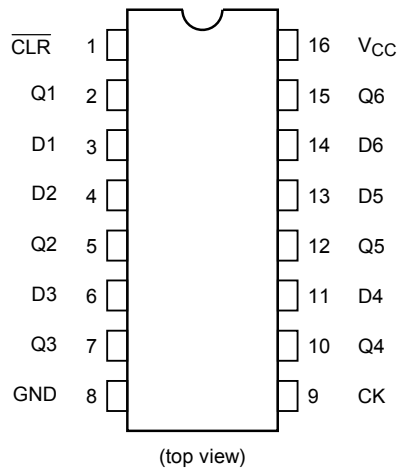

## IEC Logic Symbol

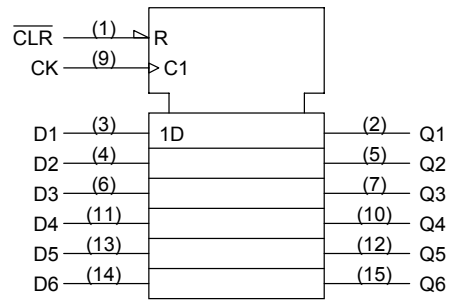

## Truth Table

Inputs			Output	Function
$\overline{\text{CLR}}$	D	CK	Q	
L	X	X	L	Clear
H	L	$\uparrow$	L	—
H	H	$\uparrow$	H	—
H	X	$\downarrow$	$Q_n$	No Change

X: Don't care

## System Diagram

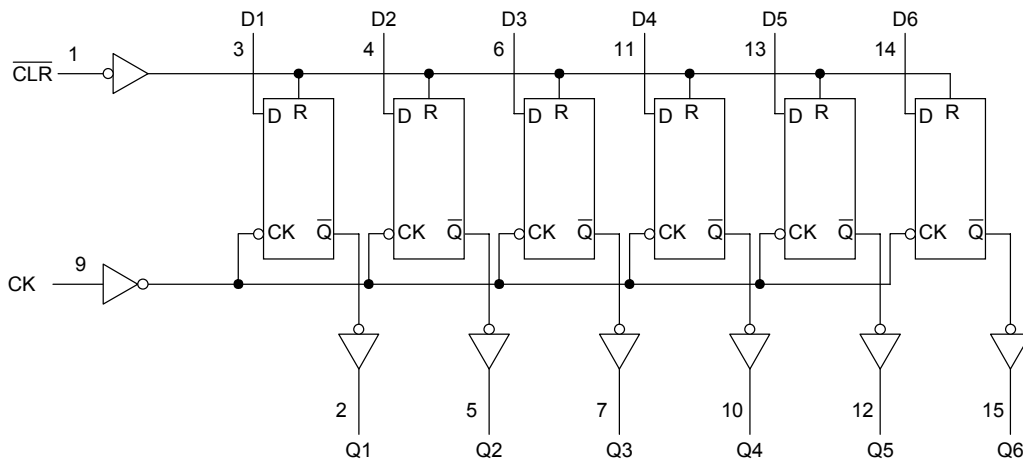

## Absolute Maximum Ratings (Note)

Characteristics	Symbol	Rating	Unit
Supply voltage range	$V_{CC}$	-0.5 to 7.0	V
DC input voltage	$V_{IN}$	-0.5 to 7.0	V
DC output voltage	$V_{OUT}$	-0.5 to $V_{CC} + 0.5$	V
Input diode current	$I_{IK}$	-20	mA
Output diode current	$I_{OK}$	$\pm 20$	mA
DC output current	$I_{OUT}$	$\pm 25$	mA
DC $V_{CC}$ /ground current	$I_{CC}$	$\pm 50$	mA
Power dissipation	$P_D$	180	mW
Storage temperature	$T_{stg}$	-65 to 150	$^{\circ}C$

Note: Exceeding any of the absolute maximum ratings, even briefly, lead to deterioration in IC performance or even destruction.

## Recommended Operating Conditions (Note)

Characteristics	Symbol	Rating	Unit
Supply voltage	$V_{CC}$	2.0 to 5.5	V
Input voltage	$V_{IN}$	0 to 5.5	V
Output voltage	$V_{OUT}$	0 to $V_{CC}$	V
Operating temperature	$T_{opr}$	-40 to 85	$^{\circ}C$
Input rise and fall time	dt/dv	0 to 100 ( $V_{CC} = 3.3 \pm 0.3$ V) 0 to 20 ( $V_{CC} = 5 \pm 0.5$ V)	ns/V

Note: The recommended operating conditions are required to ensure the normal operation of the device. Unused inputs must be tied to either VCC or GND.

## Electrical Characteristics

### DC Characteristics

Characteristics	Symbol	Test Condition		Ta = 25°C			Ta = -40 to 85°C		Unit	
				V <sub>CC</sub> (V)	Min	Typ.	Max	Min		Max
High-level input voltage	V <sub>IH</sub>	—		2.0 3.0 to 5.5	1.50 V <sub>CC</sub> × 0.7	— —	— —	1.50 V <sub>CC</sub> × 0.7	— —	V
Low-level input voltage	V <sub>IL</sub>	—		2.0 3.0 to 5.5	— —	— —	0.50 V <sub>CC</sub> × 0.3	— —	0.50 V <sub>CC</sub> × 0.3	V
High-level output voltage	V <sub>OH</sub>	V <sub>IN</sub> = V <sub>IH</sub> or V <sub>IL</sub>	I <sub>OH</sub> = -50 μA	2.0 3.0 4.5	1.9 2.9 4.4	2.0 3.0 4.5	— — —	1.9 2.9 4.4	— — —	V
			I <sub>OH</sub> = -4 mA	3.0	2.58	—	—	2.48	—	
			I <sub>OH</sub> = -8 mA	4.5	3.94	—	—	3.80	—	
Low-level output voltage	V <sub>OL</sub>	V <sub>IN</sub> = V <sub>IH</sub> or V <sub>IL</sub>	I <sub>OL</sub> = 50 μA	2.0 3.0 4.5	— — —	0.0 0.0 0.0	0.1 0.1 0.1	— — —	0.1 0.1 0.1	V
			I <sub>OL</sub> = 4 mA	3.0	—	—	0.36	—	0.44	
			I <sub>OL</sub> = 8 mA	4.5	—	—	0.36	—	0.44	
Input leakage current	I <sub>IN</sub>	V <sub>IN</sub> = 5.5 V or GND		0 to 5.5	—	—	±0.1	—	±1.0	μA
Quiescent supply current	I <sub>CC</sub>	V <sub>IN</sub> = V <sub>CC</sub> or GND		5.5	—	—	4.0	—	40.0	μA

### Timing Requirements (input: t<sub>r</sub> = t<sub>f</sub> = 3 ns)

Characteristics	Symbol	Test Condition		Ta = 25°C		Ta = -40 to 85°C	Unit	
				V <sub>CC</sub> (V)	Typ.	Limit		Limit
Minimum pulse width (CK)	t <sub>w</sub> (L)	—		3.3 ± 0.3	—	5.0	5.0	ns
	t <sub>w</sub> (H)	—		5.0 ± 0.5	—	5.0	5.0	
Minimum pulse width ( $\overline{\text{CLR}}$ )	t <sub>w</sub> (L)	—		3.3 ± 0.3 5.0 ± 0.5	— —	5.0 5.0	5.0 5.0	ns
Minimum set-up time	t <sub>s</sub>	—		3.3 ± 0.3	—	5.0	6.0	ns
		—		5.0 ± 0.5	—	4.5	4.5	
Minimum hold time	t <sub>h</sub>	—		3.3 ± 0.3	—	0.0	0.0	ns
		—		5.0 ± 0.5	—	0.5	0.5	
Minimum removal time ( $\overline{\text{CLR}}$ )	t <sub>rem</sub>	—		3.3 ± 0.3	—	3.0	3.0	ns
		—		5.0 ± 0.5	—	2.5	2.5	

## AC Characteristics (input: $t_r = t_f = 3$ ns)

Characteristics	Symbol	Test Condition	Ta = 25°C			Ta = -40 to 85°C		Unit		
			V <sub>CC</sub> (V)	C <sub>L</sub> (pF)	Min	Typ.	Max		Min	Max
Propagation delay time (CK-Q)	t <sub>pLH</sub>	—	3.3 ± 0.3	15	—	7.2	11.0	1.0	13.0	ns
				50	—	9.7	14.5	1.0	16.5	
	5.0 ± 0.5		15	—	4.9	7.2	1.0	8.5		
			50	—	6.4	9.2	1.0	10.5		
Propagation delay time ( $\overline{\text{CLR}}-Q$ )	t <sub>pHL</sub>	—	3.3 ± 0.3	15	—	7.4	11.4	1.0	13.5	ns
				50	—	9.9	14.9	1.0	17.0	
			5.0 ± 0.5	15	—	5.1	7.6	1.0	9.0	
				50	—	6.6	9.6	1.0	11.0	
Maximum clock frequency	f <sub>max</sub>	—	3.3 ± 0.3	15	95	150	—	80	—	MHz
				50	55	85	—	50	—	
			5.0 ± 0.5	15	130	175	—	110	—	
				50	90	120	—	80	—	
Output to output skew	t <sub>osLH</sub>	(Note 1)	3.3 ± 0.3	50	—	—	1.5	—	1.5	ns
	t <sub>osHL</sub>		5.5 ± 0.5	50	—	—	1.0	—	1.0	
Input capacitance	C <sub>IN</sub>	—	—	—	4	10	—	10	pF	
Power dissipation capacitance	C <sub>PD</sub>	(Note 2)	—	—	29	—	—	—	pF	

Note 1: Parameter guaranteed by design.

$$t_{osLH} = |t_{pLHm} - t_{pLHn}|, t_{osHL} = |t_{pHLm} - t_{pHLn}|$$

Note 2: C<sub>PD</sub> is defined as the value of the internal equivalent capacitance which is calculated from the operating current consumption without load.

Average operating current can be obtained by the equation:

$$I_{CC(opr)} = C_{PD} \cdot V_{CC} \cdot f_{IN} + I_{CC}/6 \text{ (per F/F)}$$

And the total C<sub>PD</sub> when n pcs. of flip flop operate can be gained by the following equation:

$$C_{PD} \text{ (total)} = 19 + 10 \cdot n$$

## Noise Characteristics (input: $t_r = t_f = 3$ ns)

Characteristics	Symbol	Test Condition	Ta = 25°C			Unit
			V <sub>CC</sub> (V)	Typ.	Max	
Quiet output maximum dynamic V <sub>OL</sub>	V <sub>OLP</sub>	C <sub>L</sub> = 50 pF	5.0	0.4	0.8	V
Quiet output minimum dynamic V <sub>OL</sub>	V <sub>OLV</sub>	C <sub>L</sub> = 50 pF	5.0	-0.4	-0.8	V
Minimum high level dynamic input voltage	V <sub>IHD</sub>	C <sub>L</sub> = 50 pF	5.0	—	3.5	V
Maximum low level dynamic input voltage	V <sub>ILD</sub>	C <sub>L</sub> = 50 pF	5.0	—	1.5	V

**Input Equivalent Circuit**

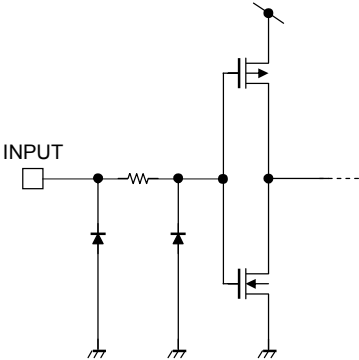

## Package Dimensions

SOP16-P-300-1.27A

Unit: mm

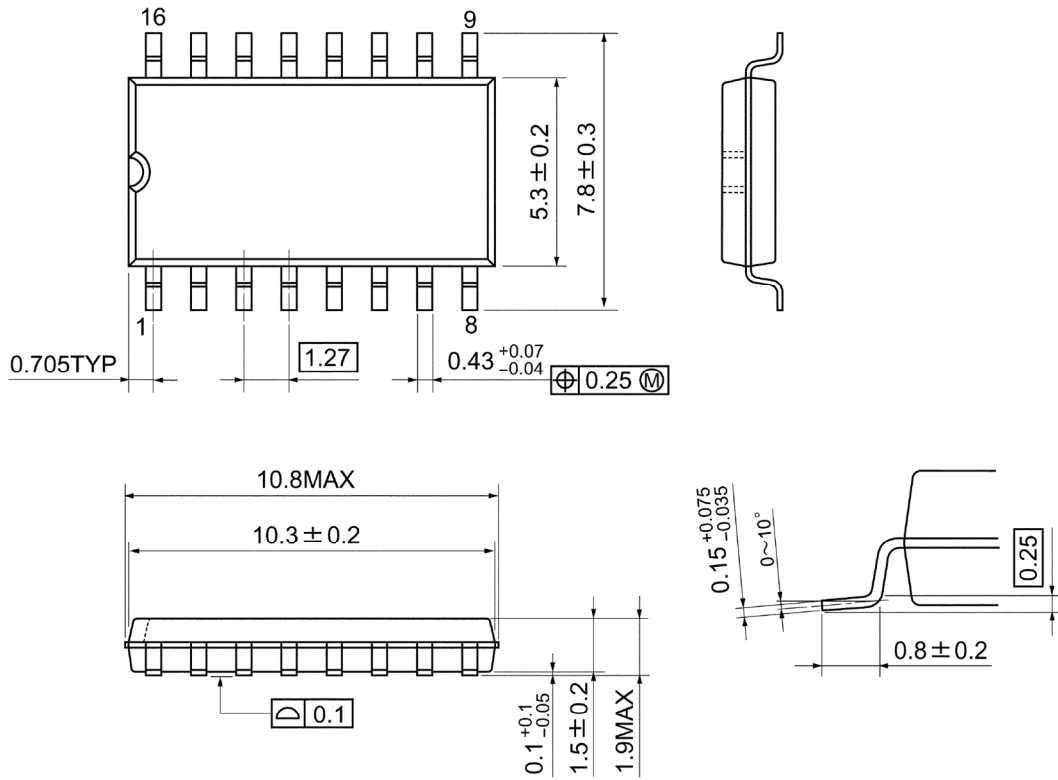

Weight: 0.18 g (typ.)

## Package Dimensions

SOP16-P-300-1.27

Unit : mm

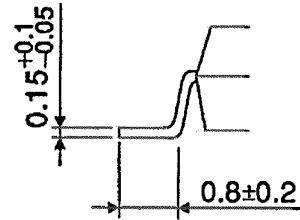
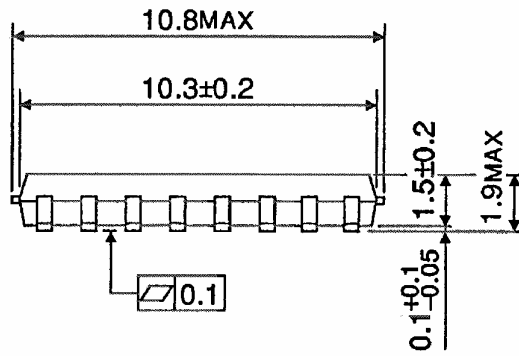
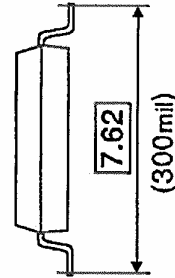
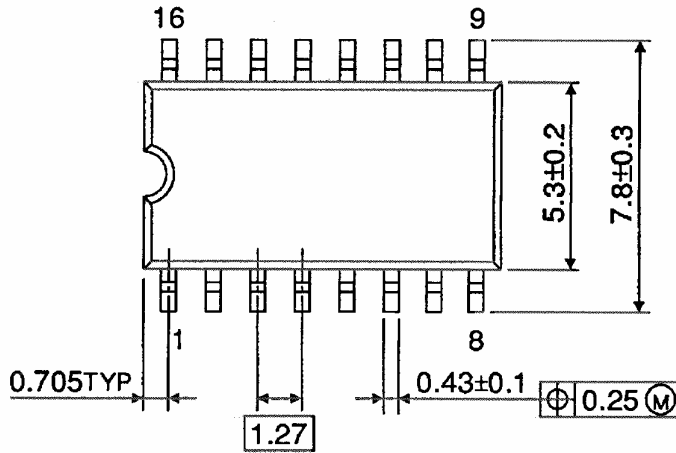

Weight: 0.18 g (typ.)



Package Dimensions (Note)

SOL16-P-150-1.27

Unit : mm

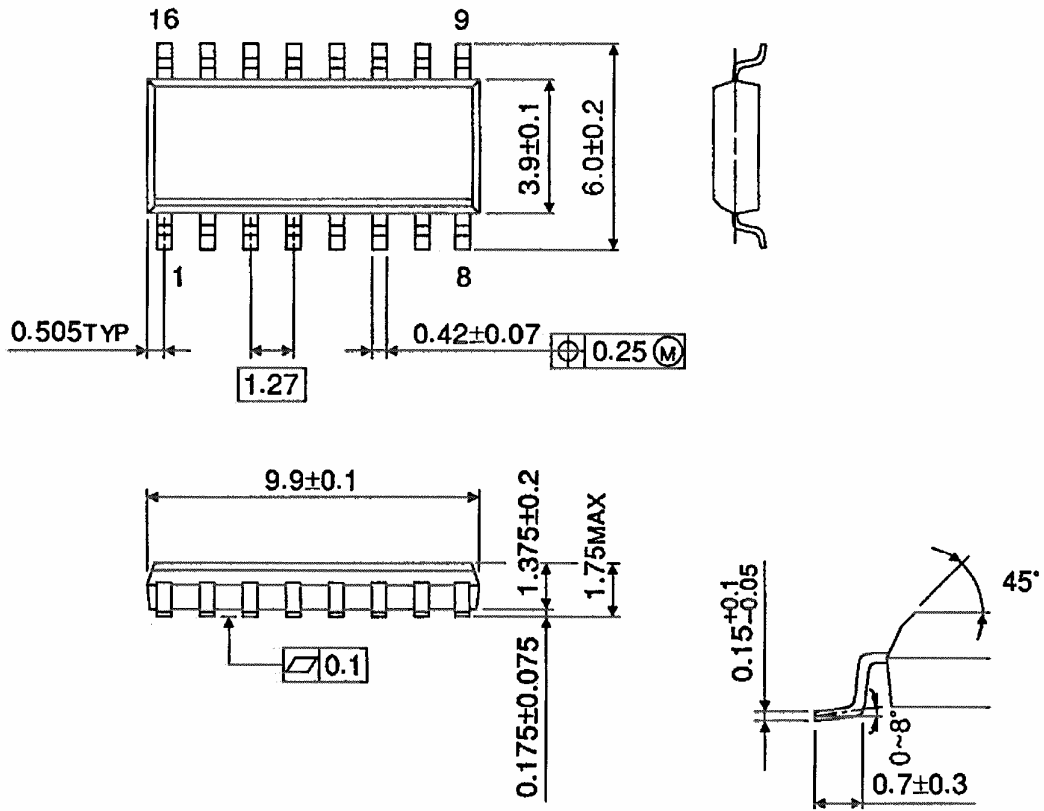

Note: This package is not available in Japan.

Weight: 0.13 g (typ.)

Package Dimensions

TSSOP16-P-0044-0.65

Unit : mm

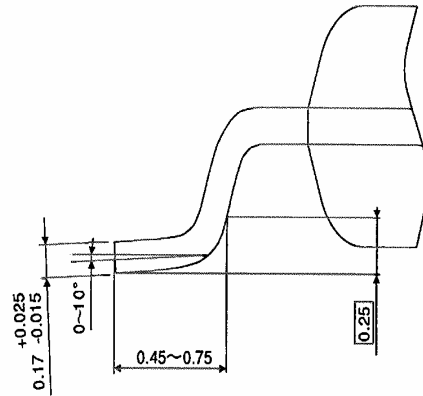
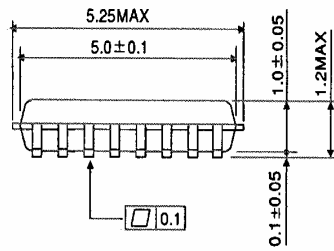
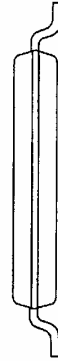
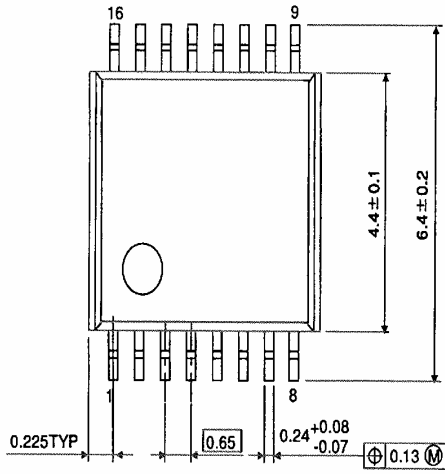

Weight: 0.06 g (typ.)

**Note: Lead (Pb)-Free Packages****SOP16-P-300-1.27A SOL16-P-150-1.27 TSSOP16-P-0044-0.65A****RESTRICTIONS ON PRODUCT USE**

060116EBA

- The information contained herein is subject to change without notice. 021023\_D
- TOSHIBA is continually working to improve the quality and reliability of its products. Nevertheless, semiconductor devices in general can malfunction or fail due to their inherent electrical sensitivity and vulnerability to physical stress. It is the responsibility of the buyer, when utilizing TOSHIBA products, to comply with the standards of safety in making a safe design for the entire system, and to avoid situations in which a malfunction or failure of such TOSHIBA products could cause loss of human life, bodily injury or damage to property.  
In developing your designs, please ensure that TOSHIBA products are used within specified operating ranges as set forth in the most recent TOSHIBA products specifications. Also, please keep in mind the precautions and conditions set forth in the "Handling Guide for Semiconductor Devices," or "TOSHIBA Semiconductor Reliability Handbook" etc. 021023\_A
- The TOSHIBA products listed in this document are intended for usage in general electronics applications (computer, personal equipment, office equipment, measuring equipment, industrial robotics, domestic appliances, etc.). These TOSHIBA products are neither intended nor warranted for usage in equipment that requires extraordinarily high quality and/or reliability or a malfunction or failure of which may cause loss of human life or bodily injury ("Unintended Usage"). Unintended Usage include atomic energy control instruments, airplane or spaceship instruments, transportation instruments, traffic signal instruments, combustion control instruments, medical instruments, all types of safety devices, etc. Unintended Usage of TOSHIBA products listed in this document shall be made at the customer's own risk. 021023\_B
- The products described in this document shall not be used or embedded to any downstream products of which manufacture, use and/or sale are prohibited under any applicable laws and regulations. 060106\_Q
- The information contained herein is presented only as a guide for the applications of our products. No responsibility is assumed by TOSHIBA for any infringements of patents or other rights of the third parties which may result from its use. No license is granted by implication or otherwise under any patent or patent rights of TOSHIBA or others. 021023\_C
- The products described in this document are subject to the foreign exchange and foreign trade laws. 021023\_E