

TC7MPB9326FT,TC7MPB9327FT

1. Functional Description

- Low-Voltage, Low-Power Dual SPDT Supply Bus Switch

2. General

The TC7MPB9326FT and TC7MPB9327FT are CMOS dual multiplexer/demultiplexer bus switches that can provide an interface between two nodes at different voltage levels. These devices can be connected to two independent power supplies. V_{CCA} supports 1.8 V, 2.5 V and 3.3 V power supplies, whereas V_{CCB} supports 2.5 V, 3.3 V and 5.0 V power supplies.

Bidirectional level-shifting is possible by simply adding external pull-up resistors between the A/Bn data lines and the V_{CCA} / V_{CCB} supplies. There is no restriction on the relative magnitude of the A and Bn voltages; both the 1A/2A and 1B1/1B2, 2B1/2B2 data lines can be pulled up to the arbitrary power supplies.

The Output Enable pin (OE) can be used to disable the device so that the bus lines are effectively isolated.

This device consists of dual individual two-inputs multiplexer/demultiplexer with a common select input (S) and an output enable (OE:TC7MPB9326FT, \overline{OE} :TC7MPB9327FT). The 1A/2A inputs are connected to 1B1/1B2 and 2B1/2B2 outputs based on the combination of select input and output enable.

For TC7MPB9326FT, it has an active high Output Enable (OE) : When OE is High, the switch is on; When Low, the switch is turned off. For the TC7MPB9327FT, it has an active low Output Enable (\overline{OE}) : When \overline{OE} is Low, the switch is turned on; When \overline{OE} is High, the switch is off.

The TC7MPB9326FT and TC7MPB9327FT supports power-down protection at the \overline{OE} , OE input, with \overline{OE} , OE being 5.5 V tolerant.

The channels consist of n-type MOSFETs.

All the inputs provide protection against electrostatic discharge.

3. Features

- (1) Wide operating temperature range: $T_{opr} = -40$ to 125 °C (Note 1)
- (2) Operating voltage: 1.8 V to 2.5 V / 1.8 V to 3.3 V / 1.8 V to 5.0 V / 2.5 V to 3.3 V / 2.5 V to 5.0 V / 3.3 V to 5.0 V bidirectional interface
- (3) Operating voltage: $V_{CCA} = 1.65$ to 5.0 V, $V_{CCB} = 2.3$ to 5.5 V
- (4) Low ON-resistance: $R_{ON} = 5.0$ Ω (typ.) @ $V_{IS} = 0$ V, $I_{IS} = 30$ mA, $V_{CCA} = 3.0$ V, $V_{CCB} = 4.5$ V
- (5) ESD performance: MM $\geq \pm 200$ V, HBM $\geq \pm 2000$ V
- (6) 5.5 V tolerance and power-down protection at the Output Enable input.
- (7) Packages: TSSOP14

Note 1: Operating Range spec of $T_{opr} = -40$ °C to 125 °C is applicable only for the products which manufactured after April 2020.

Start of commercial production
2020-04

4. Packaging

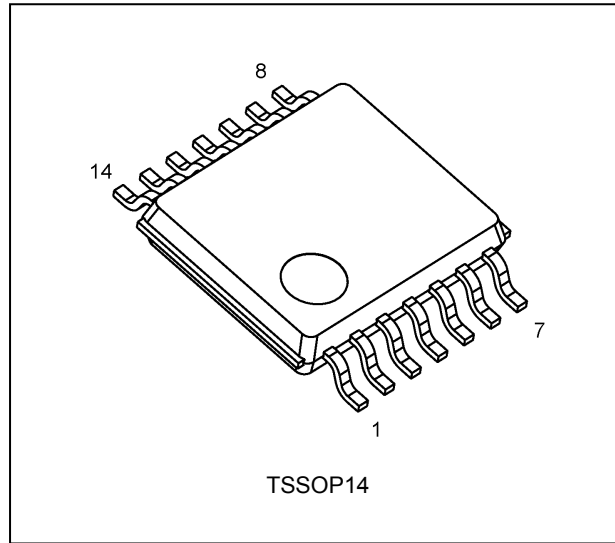

5. Pin Assignment

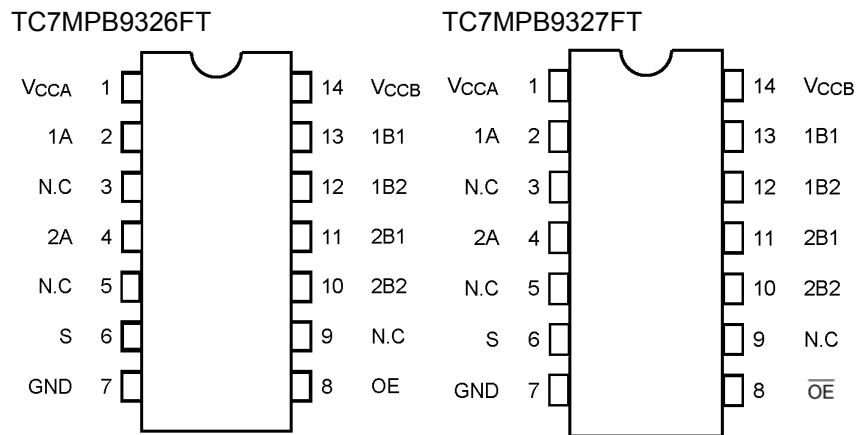

6. Marking

TC7MPB9326FT

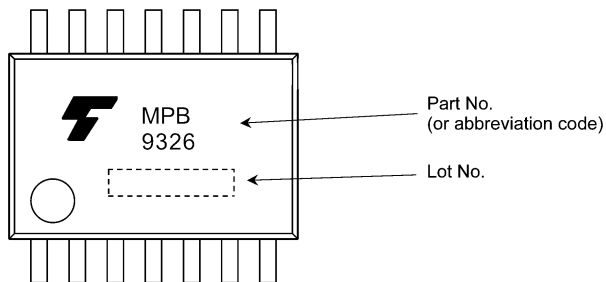

TC7MPB9327FT

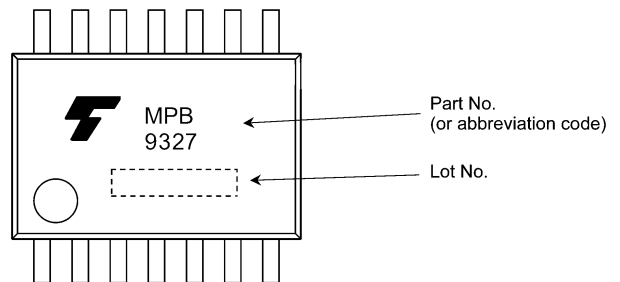

7. Block Diagram

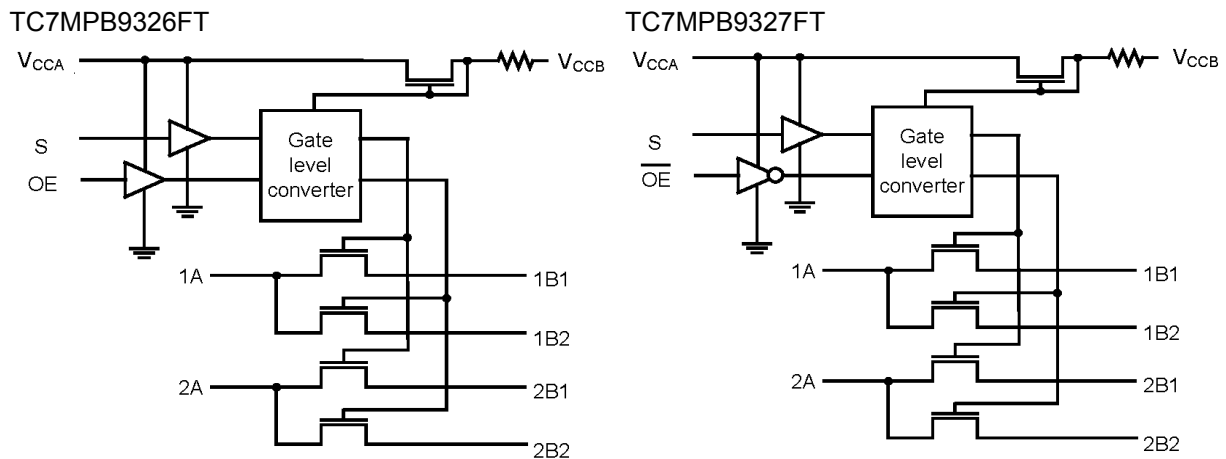

8. Truth Table

Inputs (9326) OE	Inputs (9327) OE	Inputs S	Function
H	L	L	A = B1
H	L	H	A = B2
L	H	X	Disconnect

9. Absolute Maximum Ratings (Note)

Characteristics	Symbol	Note	Rating	Unit
Supply voltage	V_{CCA}		-0.5 to 7.0	V
	V_{CCB}		-0.5 to 7.0	
Input voltage	V_{IN}		-0.5 to 7.0	V
Switch I/O voltage	V_S		-0.5 to 7.0	V
Clamp diode current	I_{IK}		-50	mA
Switch I/O current	I_S		64	mA
V_{CC} /ground current per supply pin	I_{CCA}		± 25	mA
	I_{CCB}		± 25	
Power dissipation	P_D	(Note 1)	180	mW
Storage temperature	T_{stg}		-65 to 150	$^{\circ}C$

Note: Exceeding any of the absolute maximum ratings, even briefly, lead to deterioration in IC performance or even destruction.

Using continuously under heavy loads (e.g. the application of high temperature/current/voltage and the significant change in temperature, etc.) may cause this product to decrease in the reliability significantly even if the operating conditions (i.e. operating temperature/current/voltage, etc.) are within the absolute maximum ratings and the operating ranges.

Please design the appropriate reliability upon reviewing the Toshiba Semiconductor Reliability Handbook ("Handling Precautions"/"Derating Concept and Methods") and individual reliability data (i.e. reliability test report and estimated failure rate, etc).

Note 1: 180 mW in the range of $T_a = -40$ to 85. From $T_a = 85$ to 125 $^{\circ}C$ a derating factor of -3.25 mW/ $^{\circ}C$ shall be applied until 50 mW.

10. Operating Ranges (Note)

Characteristics	Symbol	Note	Rating	Unit
Supply voltage	V_{CCA}	(Note 1)	1.65 to 5.0	V
	V_{CCB}		2.3 to 5.5	
Input voltage	V_{IN}		0 to 5.5	V
Switch I/O voltage	V_S		0 to 5.5	V
Operating temperature	T_{opr}	(Note 2)	-40 to 125	°C
Input rise time	dt/dv		0 to 10	ns/V
Input fall time	dt/dv		0 to 10	

Note : The operating ranges must be maintained to ensure the normal operation of the device.

Unused inputs and bus inputs must be tied to either V_{CCA} or GND.

Note 1: The V_{CCA} voltage must be lower than the V_{CCB} voltage.

Note 2: Operating Ranges of $T_a = -40\text{ °C}$ to 125 °C are only applicable for products which manufactured from April 2020 onward.

11. Application Circuit (Note)

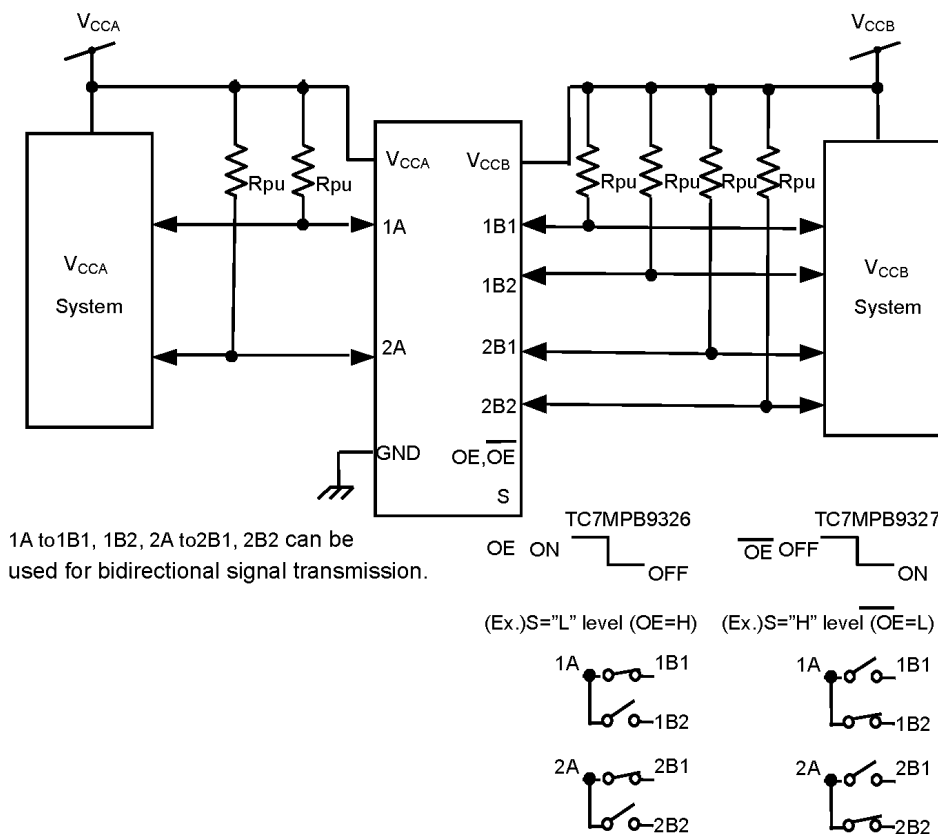

Note: The $V_{CCA} < V_{CCB}$ voltage must be lower than the V_{CCB} voltage.

Note: Level-shifting functionality is enabled by adding pull-up resistors from An to V_{CCA} or V_{CCB} and from Bn to V_{CCB} or V_{CCA} , respectively.

12. Electrical Characteristics

12.1. DC Characteristics (Unless otherwise specified, $T_a = -40$ to 85 °C)

Characteristics	Symbol	Note	Test Condition	V_{CCA} (V)	V_{CCB} (V)	Min	Max	Unit	
High-level input voltage (OE/ \overline{OE} , S)	V_{IH}		—	$1.65 \leq V_{CCA} < 2.3$	V_{CCA} to 5.5	$0.8 \times V_{CCA}$	—	V	
				$2.3 \leq V_{CCA} < 5.0$	V_{CCA} to 5.5	$0.7 \times V_{CCA}$	—		
Low-level input voltage (OE/ \overline{OE} , S)	V_{IL}		—	$1.65 \leq V_{CCA} < 2.3$	V_{CCA} to 5.5	—	$0.2 \times V_{CCA}$	V	
				$2.3 \leq V_{CCA} < 5.0$	V_{CCA} to 5.5	—	$0.3 \times V_{CCA}$		
ON-resistance	R_{ON}	(Note 1)	$V_{IS} = 0$ V, $I_{IS} = 30$ mA See Figure 13.1	1.65	2.3	—	16.0	Ω	
				2.3	3.0	—	11.0		
				3.0	4.5	—	8.0		
Power-OFF leakage current	I_{OFF}		1A, 2A, 1Bn, 2Bn = 0 to 5.5 V (per circuit)	0	0	—	± 1.0	μ A	
Switch OFF-state leakage current	I_{SZ}		1A, 2A, 1Bn, 2Bn = 0 to 5.5 V OE = GND, $\overline{OE} = V_{CCA}$	1.65 to 5.0	V_{CCA} to 5.5	—	± 1.0	μ A	
Input leakage current	I_{IN}		OE, \overline{OE} , S = 0 to 5.5 V	1.65 to 5.0	V_{CCA} to 5.5	—	± 1.0	μ A	
Leakage current from V_{CCB} to V_{CCA}	I_{CCBA}		OE, $\overline{OE} =$ GND or V_{CCA} $V_{CCB} \rightarrow V_{CCA}$	3.3	5.0	—	20.0	μ A	
Quiescent supply current	I_{CCA1}		OE, $\overline{OE} = V_{CCA}$ or GND, $I_{IS} = 0$ A	1.65 to 5.0	V_{CCA}	—	4.0	μ A	
	I_{CCB1}			1.65 to 5.0	V_{CCA}	—	4.0		
	I_{CCA2}			$V_{CCA} \leq$ OE, $\overline{OE} \leq 5.5$ V, $I_{IS} = 0$ A	1.65 to 5.0	V_{CCA}	—		± 4.0
	I_{CCB2}			$V_{CCA} \leq$ OE, $\overline{OE} \leq 5.5$ V, $I_{IS} = 0$ A	1.65 to 5.0	V_{CCA}	—		± 4.0

Note 1: ON-resistance is measured by measuring the voltage drop across the switch at the indicated current.

12.2. DC Characteristics (Note) (Unless otherwise specified, $T_a = -40$ to 125 °C)

Characteristics	Symbol	Note	Test Condition	V_{CCA} (V)	V_{CCB} (V)	Min	Max	Unit
High-level input voltage (OE/ \overline{OE} , S)	V_{IH}		—	$1.65 \leq V_{CCA} < 2.3$	V_{CCA} to 5.5	$0.8 \times V_{CCA}$	—	V
				$2.3 \leq V_{CCA} < 5.0$	V_{CCA} to 5.5	$0.7 \times V_{CCA}$	—	
Low-level input voltage (OE/ \overline{OE} , S)	V_{IL}		—	$1.65 \leq V_{CCA} < 2.3$	V_{CCA} to 5.5	—	$0.2 \times V_{CCA}$	V
				$2.3 \leq V_{CCA} < 5.0$	V_{CCA} to 5.5	—	$0.3 \times V_{CCA}$	
ON-resistance	R_{ON}	(Note 1)	$V_{IS} = 0$ V, $I_{IS} = 30$ mA See Figure 13.1	1.65	2.3	—	25.0	Ω
				2.3	3.0	—	16.0	
				3.0	4.5	—	12.0	
Power-OFF leakage current	I_{OFF}		1A, 2A, 1Bn, 2Bn = 0 to 5.5 V (per circuit)	0	0	—	± 4.0	μ A
Switch OFF-state leakage current	I_{SZ}		1A, 2A, 1Bn, 2Bn = 0 to 5.5 V OE = GND, $\overline{OE} = V_{CCA}$	1.65 to 5.0	V_{CCA} to 5.5	—	± 4.0	μ A
Input leakage current	I_{IN}		OE, \overline{OE} , S = 0 to 5.5 V	1.65 to 5.0	V_{CCA} to 5.5	—	± 4.0	μ A
Leakage current form V_{CCB} to V_{CCA}	I_{CCBA}		OE, $\overline{OE} =$ GND or V_{CCA} $V_{CCB} \rightarrow V_{CCA}$	3.3	5.0	—	40.0	μ A
Quiescent supply current	I_{CCA1}		OE, $\overline{OE} = V_{CCA}$ or GND, $I_{IS} = 0$ A	1.65 to 5.0	V_{CCA}	—	20.0	μ A
	I_{CCB1}		OE, $\overline{OE} = V_{CCA}$ or GND, $I_{IS} = 0$ A	1.65 to 5.0	V_{CCA}	—	20.0	
	I_{CCA2}		$V_{CCA} \leq OE$, $\overline{OE} \leq 5.5$ V, $I_{IS} = 0$ A	1.65 to 5.0	V_{CCA}	—	± 20.0	
	I_{CCB2}		$V_{CCA} \leq OE$, $\overline{OE} \leq 5.5$ V, $I_{IS} = 0$ A	1.65 to 5.0	V_{CCA}	—	± 20.0	

Note: Operating Range spec of $T_{opr} = -40$ °C to 125 °C is applicable only for the products which manufactured after April 2020.

Note 1: ON-resistance is measured by measuring the voltage drop across the switch at the indicated current.

12.3. Level Shift Characteristics (Unless otherwise specified, $T_a = -40$ to 85 °C)

Characteristics	Symbol	Note	Test Condition	V_{CCA} (V)	V_{CCB} (V)	Min	Max	Unit
Input/Output characteristics (translating up)	V_{OHU}	(Note 1)	1A, 2A = V_{IN} SW = ON See Fig. 15.1.	1.65	3.0 to 5.5	1.4	—	V
				2.3	4.5 to 5.5	2.05	—	
				3.0	4.5 to 5.5	2.7	—	
Input/Output characteristics (translating down)	V_{OHD}	(Note 2)	1A, 2A = V_{CCA} SW = ON See Fig. 16.1.	1.65	3.3 to 5.5	1.3	1.65	V
				2.3	4.5 to 5.5	1.95	2.3	
				3.0	4.5 to 5.5	2.6	3.0	

Note 1: The Input/Output characteristics for translating up indicate the input voltages required to provide $V_{CCA} + 0.5$ V on the outputs when measured using the test circuitry shown in Fig. 15.1.

Note 2: The Input/Output characteristics for translating down indicate the voltages that cause the output voltages to saturate when measured using the test circuitry shown in Fig. 16.1.

12.4. Level Shift Characteristics (Note) (Unless otherwise specified, $T_a = -40$ to 125 °C)

Characteristics	Symbol	Note	Test Condition	V_{CCA} (V)	V_{CCB} (V)	Min	Max	Unit
Input/Output characteristics (translating up)	V_{OHU}	(Note 1)	1A, 2A = V_{IN} SW = ON See Fig. 15.1.	1.65	3.0 to 5.5	1.4	—	V
				2.3	4.5 to 5.5	2.05	—	
				3.0	4.5 to 5.5	2.7	—	
Input/Output characteristics (translating down)	V_{OHD}	(Note 2)	1A, 2A = V_{CCA} SW = ON See Fig. 16.1.	1.65	3.3 to 5.5	1.3	1.65	V
				2.3	4.5 to 5.5	1.95	2.3	
				3.0	4.5 to 5.5	2.6	3.0	

Note: Operating Range spec of $T_{opr} = -40$ °C to 125 °C is applicable only for the products which manufactured after April 2020.

Note 1: The Input/Output characteristics for translating up indicate the input voltages required to provide $V_{CCA} + 0.5$ V on the outputs when measured using the test circuitry shown in Fig. 15.1.

Note 2: The Input/Output characteristics for translating down indicate the voltages that cause the output voltages to saturate when measured using the test circuitry shown in Fig. 16.1.

12.5. AC Characteristics

(Unless otherwise specified, $T_a = -40$ to 85 °C, Input: $t_r = t_f = 2.0$ ns, $f = 10$ kHz)

12.5.1. $V_{CCA} = 3.3 \pm 0.3$ V, $V_{CCB} = 5.0 \pm 0.5$ V

Characteristics	Symbol	Note	Test Condition	Min	Max	Unit
Propagation delay time (bus to bus)	t_{PLH}	(Note 1)	See Fig. 14.1, 14.3	—	0.3	ns
	t_{PHL}			—	1.2	
Output enable time	t_{PZL}		See Fig. 14.2, 14.4	—	9.0	ns
Output disable time	t_{PLZ}			—	11.0	ns

Note 1: This parameter is guaranteed by design but is not tested. The bus switch contributes no propagation delay other than the RC delay of the typical On resistance of the switch and the 30 pF load capacitance, when driven by an ideal voltage the source (zero output impedance).

12.5.2. $V_{CCA} = 2.5 \pm 0.2$ V, $V_{CCB} = 5.0 \pm 0.5$ V

Characteristics	Symbol	Note	Test Condition	Min	Max	Unit
Propagation delay time (bus to bus)	t_{PLH}	(Note 1)	See Fig. 14.1, 14.3	—	0.35	ns
	t_{PHL}			—	1.8	
Output enable time	t_{PZL}		See Fig. 14.2, 14.4	—	13.0	ns
Output disable time	t_{PLZ}			—	15.0	ns

Note 1: This parameter is guaranteed by design but is not tested. The bus switch contributes no propagation delay other than the RC delay of the typical On resistance of the switch and the 30 pF load capacitance, when driven by an ideal voltage the source (zero output impedance).

12.5.3. $V_{CCA} = 2.5 \pm 0.2$ V, $V_{CCB} = 3.3 \pm 0.3$ V

Characteristics	Symbol	Note	Test Condition	Min	Max	Unit
Propagation delay time (bus to bus)	t_{PLH}	(Note 1)	See Fig. 14.1, 14.3	—	0.45	ns
	t_{PHL}			—	2.2	
Output enable time	t_{PZL}		See Fig. 14.2, 14.4	—	17.0	ns
Output disable time	t_{PLZ}			—	19.0	ns

Note 1: This parameter is guaranteed by design but is not tested. The bus switch contributes no propagation delay other than the RC delay of the typical On resistance of the switch and the 30 pF load capacitance, when driven by an ideal voltage the source (zero output impedance).

12.6. AC Characteristics (Note)

(Unless otherwise specified, $T_a = -40$ to 125 °C, Input: $t_r = t_f = 2.0$ ns, $f = 10$ kHz)

12.6.1. $V_{CCA} = 3.3 \pm 0.3$ V, $V_{CCB} = 5.0 \pm 0.5$ V

Characteristics	Symbol	Note	Test Condition	Min	Max	Unit
Propagation delay time (bus to bus)	t_{PLH}	(Note 1)	See Fig. 14.1, 14.3	—	0.5	ns
	t_{PHL}			—	1.4	
Output enable time	t_{PZL}		See Fig. 14.2, 14.4	—	13.0	ns
Output disable time	t_{PLZ}			—	15.0	ns

Note: Operating Range spec of $T_{opr} = -40$ °C to 125 °C is applicable only for the products which manufactured after April 2020.

Note 1: This parameter is guaranteed by design but is not tested. The bus switch contributes no propagation delay other than the RC delay of the typical On resistance of the switch and the 30 pF load capacitance, when driven by an ideal voltage the source (zero output impedance).

12.6.2. $V_{CCA} = 2.5 \pm 0.2$ V, $V_{CCB} = 5.0 \pm 0.5$ V

Characteristics	Symbol	Note	Test Condition	Min	Max	Unit
Propagation delay time (bus to bus)	t_{PLH}	(Note 1)	See Fig. 14.1, 14.3	—	0.55	ns
	t_{PHL}			—	2.0	
Output enable time	t_{PZL}		See Fig. 14.2, 14.4	—	17.0	ns
Output disable time	t_{PLZ}			—	19.0	ns

Note: Operating Range spec of $T_{opr} = -40$ °C to 125 °C is applicable only for the products which manufactured after April 2020.

Note 1: This parameter is guaranteed by design but is not tested. The bus switch contributes no propagation delay other than the RC delay of the typical On resistance of the switch and the 30 pF load capacitance, when driven by an ideal voltage the source (zero output impedance).

12.6.3. $V_{CCA} = 2.5 \pm 0.2$ V, $V_{CCB} = 3.3 \pm 0.3$ V

Characteristics	Symbol	Note	Test Condition	Min	Max	Unit
Propagation delay time (bus to bus)	t_{PLH}	(Note 1)	See Fig. 14.1, 14.3	—	0.65	ns
	t_{PHL}			—	2.4	
Output enable time	t_{PZL}		See Fig. 14.2, 14.4	—	21.0	ns
Output disable time	t_{PLZ}			—	23.0	ns

Note: Operating Range spec of $T_{opr} = -40$ °C to 125 °C is applicable only for the products which manufactured after April 2020.

Note 1: This parameter is guaranteed by design but is not tested. The bus switch contributes no propagation delay other than the RC delay of the typical On resistance of the switch and the 30 pF load capacitance, when driven by an ideal voltage the source (zero output impedance).

12.7. Capacitive Characteristics (Unless otherwise specified, $T_a = 25$ °C)

Characteristics	Symbol	Test Condition	V_{CCA} (V)	V_{CCB} (V)	Typ.	Unit
Input capacitance (OE/OE, S)	C_{IN}	—	3.3	3.3	3	pF
Switch terminal ON-capacitance (1A, 2A)	$C_{I/O}$	SW = ON (A, B)	3.3	3.3	14	pF
Switch terminal OFF-capacitance (1A, 2A)	$C_{I/O}$	SW = OFF (A)	3.3	3.3	7	pF
Switch terminal OFF-capacitance (1B1, 1B2, 2B1, 2B2)		SW = OFF (B)	3.3	3.3	7	

13. DC Test Circuit

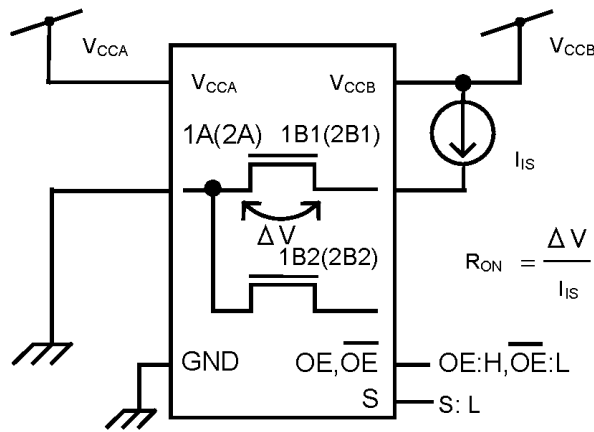

Fig. 13.1 ON-resistance Test Circuits

14. AC Test Circuits/Waveform

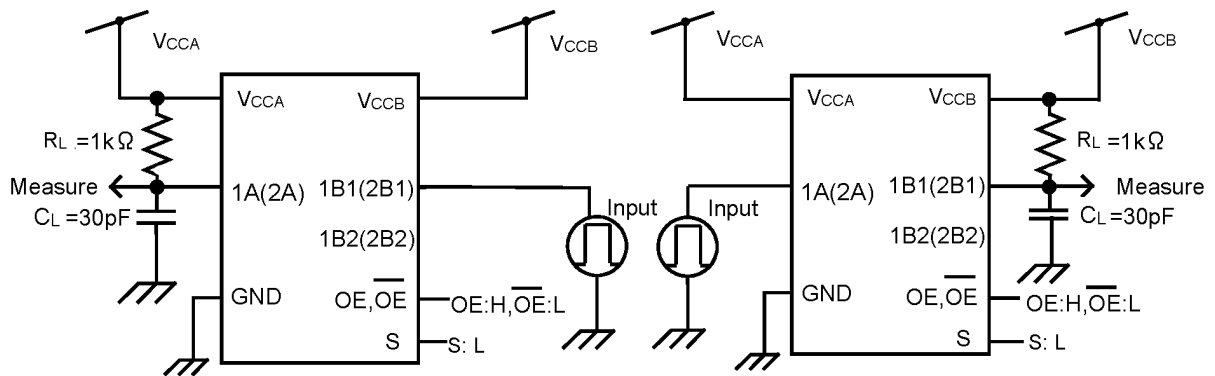

Fig. 14.1 t_{PLH}, t_{PHL} Test Circuits

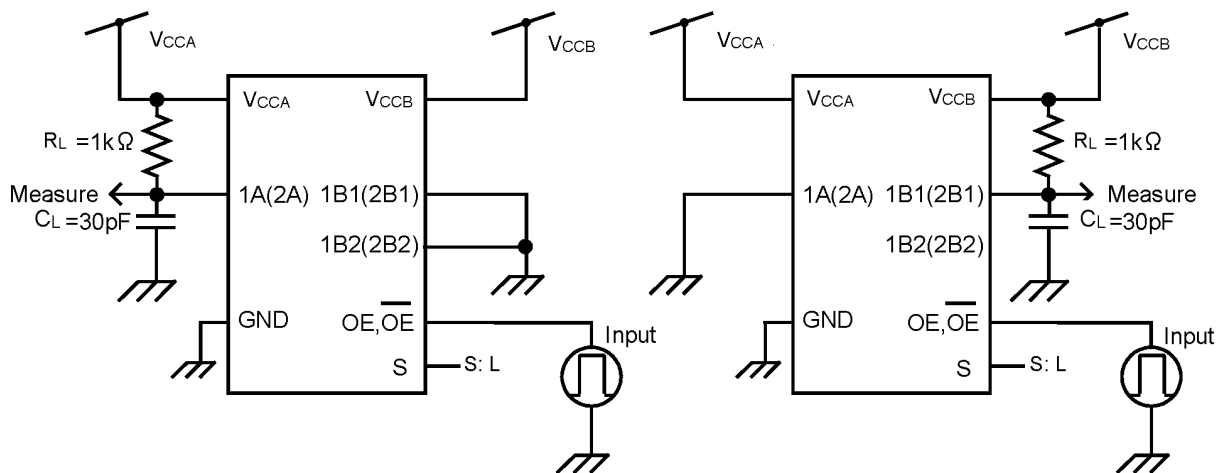

Fig. 14.2 t_{PLZ}, t_{PZL} Test Circuits

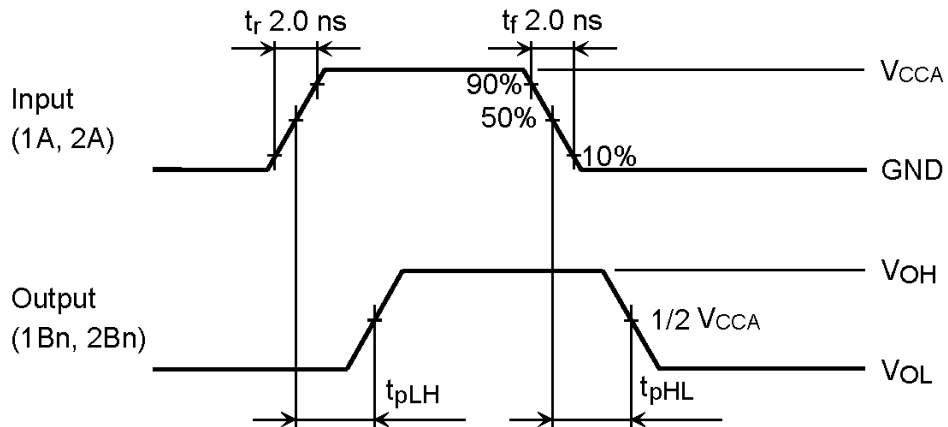

Fig. 14.3 AC Waveform of t_{pLH} , t_{pHL}

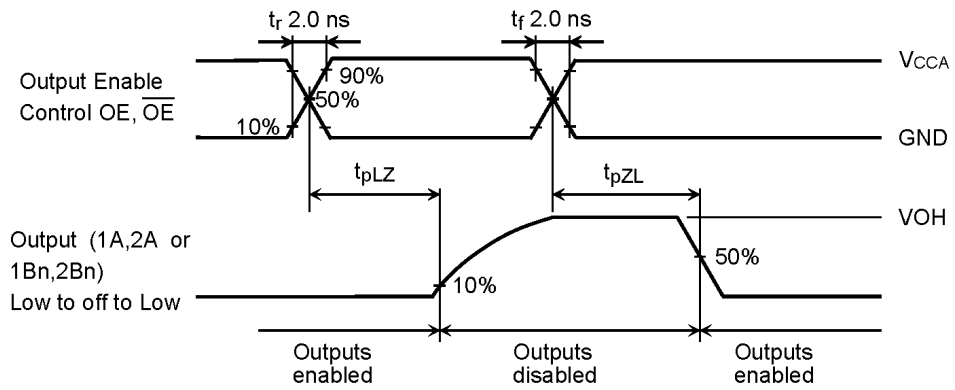

Fig. 14.4 AC Waveform of t_{pLZ} , t_{pZL}

15. Level Shift Function (Used Pull-up Resistance)

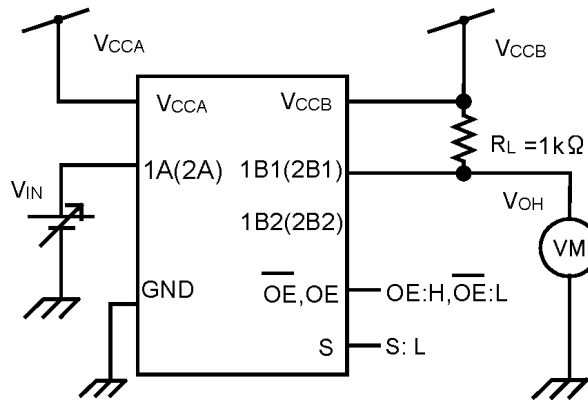

Fig. 15.1 Test Circuit

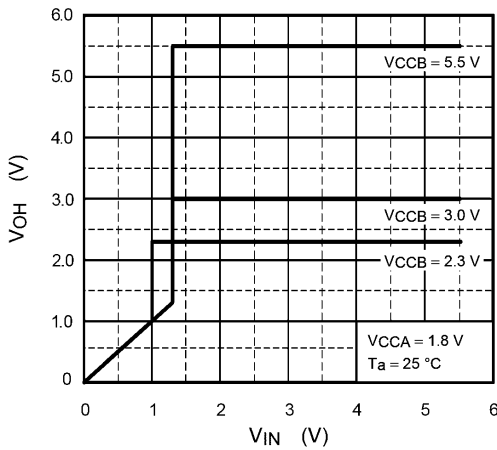

Fig. 15.2 Input/Output Characteristics (Typ.)
V_{CCA} = 1.8 V, T_a = 25 °C

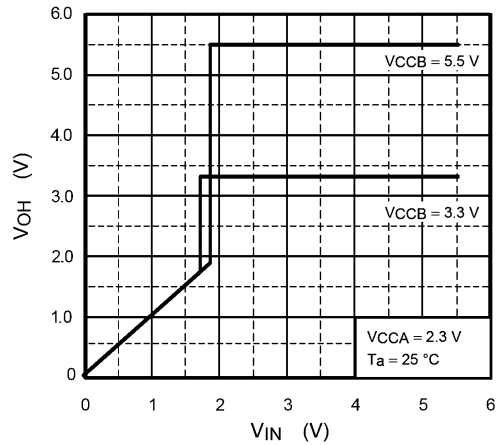

Fig. 15.3 Input/Output Characteristics (Typ.)
V_{CCA} = 2.3 V, T_a = 25 °C

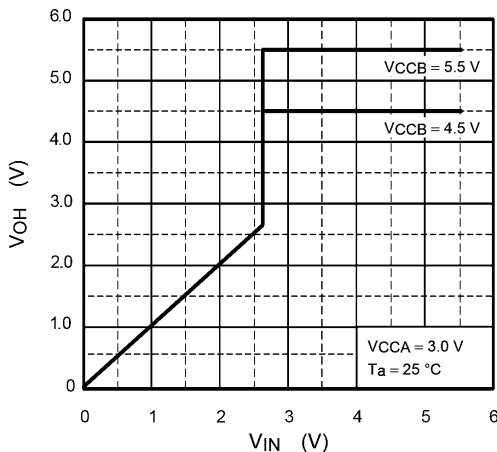

Fig. 15.4 Input/Output Characteristics (Typ.)
V_{CCA} = 3.0 V, T_a = 25 °C

Note: The above characteristics curves are presented for reference only and not guaranteed by production test, unless otherwise noted.

16. Level Shift Function (Unused Pull-up Resistance)

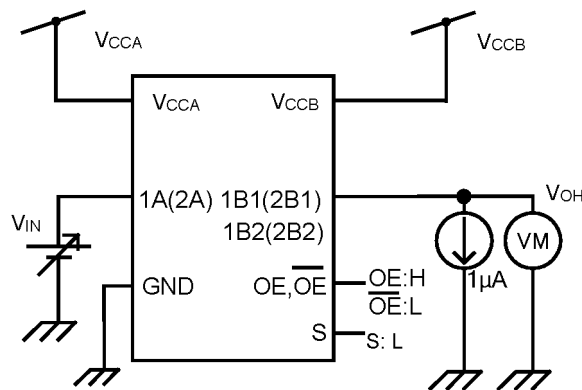

Fig. 16.1 Test Circuit

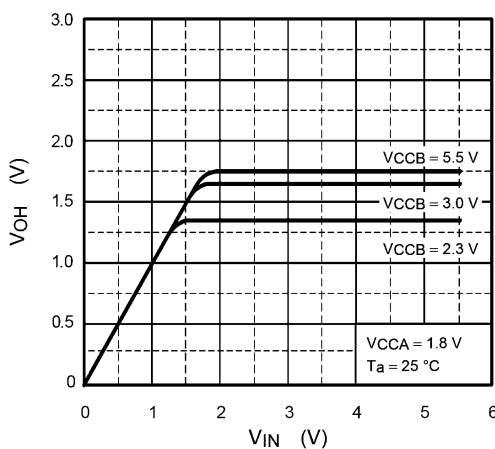

Fig. 16.2 Input/Output Characteristics (Typ.)
V_{CCA} = 1.8 V, T_a = 25 °C

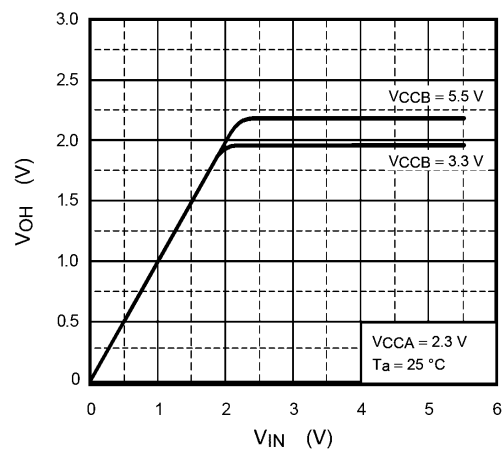

Fig. 16.3 Input/Output Characteristics (Typ.)
V_{CCA} = 2.3 V, T_a = 25 °C

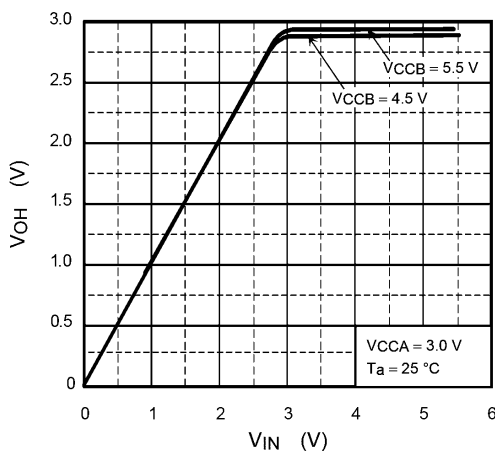
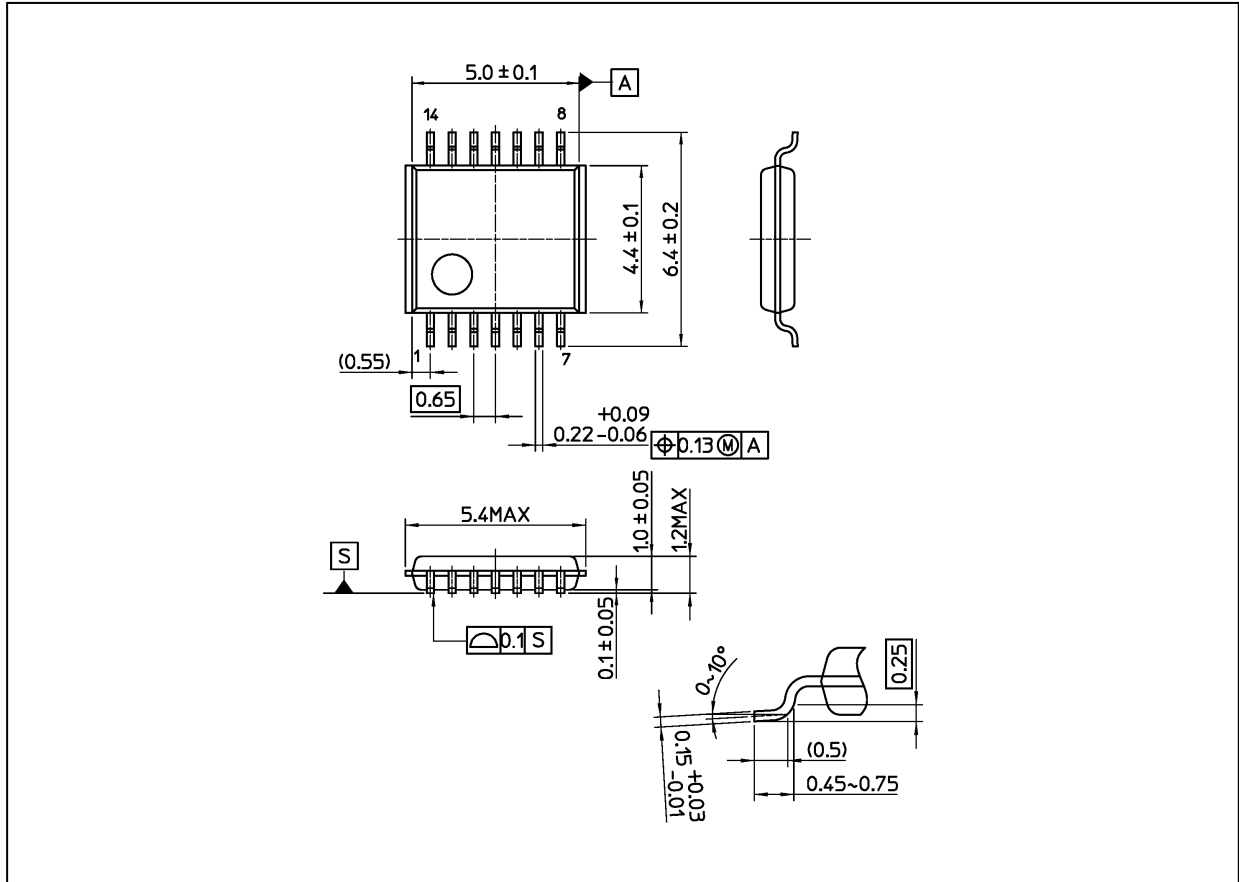

Fig. 16.4 Input/Output Characteristics (Typ.)
V_{CCA} = 3.0 V, T_a = 25 °C

Note: The above characteristics curves are presented for reference only and not guaranteed by production test, unless otherwise noted.

Package Dimensions

Unit: mm



Weight: 0.06 g (typ.)

Package Name(s)
Nickname: TSSOP14

RESTRICTIONS ON PRODUCT USE

Toshiba Corporation and its subsidiaries and affiliates are collectively referred to as "TOSHIBA".

Hardware, software and systems described in this document are collectively referred to as "Product".

- TOSHIBA reserves the right to make changes to the information in this document and related Product without notice.
- This document and any information herein may not be reproduced without prior written permission from TOSHIBA. Even with TOSHIBA's written permission, reproduction is permissible only if reproduction is without alteration/omission.
- Though TOSHIBA works continually to improve Product's quality and reliability, Product can malfunction or fail. Customers are responsible for complying with safety standards and for providing adequate designs and safeguards for their hardware, software and systems which minimize risk and avoid situations in which a malfunction or failure of Product could cause loss of human life, bodily injury or damage to property, including data loss or corruption. Before customers use the Product, create designs including the Product, or incorporate the Product into their own applications, customers must also refer to and comply with (a) the latest versions of all relevant TOSHIBA information, including without limitation, this document, the specifications, the data sheets and application notes for Product and the precautions and conditions set forth in the "TOSHIBA Semiconductor Reliability Handbook" and (b) the instructions for the application with which the Product will be used with or for. Customers are solely responsible for all aspects of their own product design or applications, including but not limited to (a) determining the appropriateness of the use of this Product in such design or applications; (b) evaluating and determining the applicability of any information contained in this document, or in charts, diagrams, programs, algorithms, sample application circuits, or any other referenced documents; and (c) validating all operating parameters for such designs and applications.
TOSHIBA ASSUMES NO LIABILITY FOR CUSTOMERS' PRODUCT DESIGN OR APPLICATIONS.

- **PRODUCT IS NEITHER INTENDED NOR WARRANTED FOR USE IN EQUIPMENTS OR SYSTEMS THAT REQUIRE EXTRAORDINARILY HIGH LEVELS OF QUALITY AND/OR RELIABILITY, AND/OR A MALFUNCTION OR FAILURE OF WHICH MAY CAUSE LOSS OF HUMAN LIFE, BODILY INJURY, SERIOUS PROPERTY DAMAGE AND/OR SERIOUS PUBLIC IMPACT ("UNINTENDED USE").**

Except for specific applications as expressly stated in this document, Unintended Use includes, without limitation, equipment used in nuclear facilities, equipment used in the aerospace industry, lifesaving and/or life supporting medical equipment, equipment used for automobiles, trains, ships and other transportation, traffic signaling equipment, equipment used to control combustions or explosions, safety devices, elevators and escalators, and devices related to power plant.

IF YOU USE PRODUCT FOR UNINTENDED USE, TOSHIBA ASSUMES NO LIABILITY FOR PRODUCT.

For details, please contact your TOSHIBA sales representative or contact us via our website.

- Do not disassemble, analyze, reverse-engineer, alter, modify, translate or copy Product, whether in whole or in part.
- Product shall not be used for or incorporated into any products or systems whose manufacture, use, or sale is prohibited under any applicable laws or regulations.
- The information contained herein is presented only as guidance for Product use. No responsibility is assumed by TOSHIBA for any infringement of patents or any other intellectual property rights of third parties that may result from the use of Product. No license to any intellectual property right is granted by this document, whether express or implied, by estoppel or otherwise.
- **ABSENT A WRITTEN SIGNED AGREEMENT, EXCEPT AS PROVIDED IN THE RELEVANT TERMS AND CONDITIONS OF SALE FOR PRODUCT, AND TO THE MAXIMUM EXTENT ALLOWABLE BY LAW, TOSHIBA (1) ASSUMES NO LIABILITY WHATSOEVER, INCLUDING WITHOUT LIMITATION, INDIRECT, CONSEQUENTIAL, SPECIAL, OR INCIDENTAL DAMAGES OR LOSS, INCLUDING WITHOUT LIMITATION, LOSS OF PROFITS, LOSS OF OPPORTUNITIES, BUSINESS INTERRUPTION AND LOSS OF DATA, AND (2) DISCLAIMS ANY AND ALL EXPRESS OR IMPLIED WARRANTIES AND CONDITIONS RELATED TO SALE, USE OF PRODUCT, OR INFORMATION, INCLUDING WARRANTIES OR CONDITIONS OF MERCHANTABILITY, FITNESS FOR A PARTICULAR PURPOSE, ACCURACY OF INFORMATION, OR NONINFRINGEMENT.**
- Do not use or otherwise make available Product or related software or technology for any military purposes, including without limitation, for the design, development, use, stockpiling or manufacturing of nuclear, chemical, or biological weapons or missile technology products (mass destruction weapons). Product and related software and technology may be controlled under the applicable export laws and regulations including, without limitation, the Japanese Foreign Exchange and Foreign Trade Law and the U.S. Export Administration Regulations. Export and re-export of Product or related software or technology are strictly prohibited except in compliance with all applicable export laws and regulations.
- Please contact your TOSHIBA sales representative for details as to environmental matters such as the RoHS compatibility of Product. Please use Product in compliance with all applicable laws and regulations that regulate the inclusion or use of controlled substances, including without limitation, the EU RoHS Directive. **TOSHIBA ASSUMES NO LIABILITY FOR DAMAGES OR LOSSES OCCURRING AS A RESULT OF NONCOMPLIANCE WITH APPLICABLE LAWS AND REGULATIONS.**