

TC9135P

TC9135P 6CH MUTUAL RESET TYPE TOUCH SWITCH

TC9135P is a 6 circuit flip-flop IC having mutual reset action. When a "L" level signal is given to one input, corresponding output only is ON and all other outputs become OFF.

This IC is effective for electronization of function selector switch of audio system.

- (6-circuit mutual reset type) and (3-circuit mutual reset type) are available for use.
- Nch open drain large current buffer is employed and small type LED relays can be directly driven.
- Input has high impedance, and by providing a touch sensor externally, a touch sensor can be easily configured.
- CMOS construction provides a broad range of operating voltage, and current consumption is low.

Unit in mm

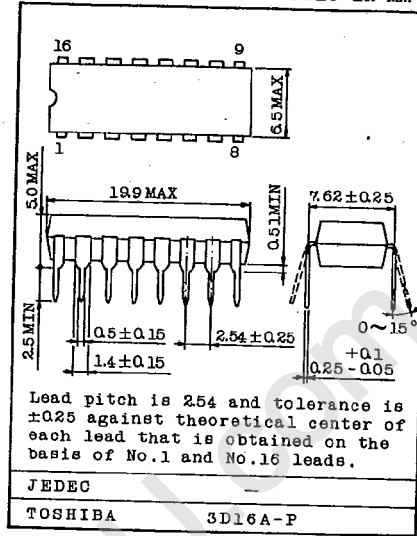

Lead pitch is 2.54 and tolerance is ± 0.25 against theoretical center of each lead that is obtained on the basis of No.1 and No.16 leads.

MAXIMUM RATINGS ($T_a=25^\circ\text{C}$)

CHARACTERISTIC	SYMBOL	RATING	UNIT
Supply Voltage	VDD	16	V
Input Voltage	VIN	-0.3 ~ VDD+0.3	V
Output Voltage	Vout	-0.3 ~ VDD+0.3	V
Output Current	Iout	30	mA
Power Dissipation	PD	600	mW
Operating Temperature	Topr	-30 ~ 75	°C
Storage Temperature	Tstg	-55 ~ 125	°C

PIN CONNECTION

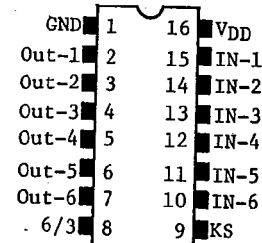

TOSHIBA

TC9135P

T-6505

ELECTRICAL CHARACTERISTICS (Unless otherwise specified, $V_{DD}=12V$, $T_a=25^\circ C$)

CHARACTERISTIC	SYMBOL	TEST CIRCUIT	TEST CONDITION	MIN.	TYP.	MAX.	UNIT
Operating Supply Voltage	V_{DD}	—		3	—	16	V
Quiescent Supply Current	I_{DD}	—	$V_{DD}=16.0V$	—	—	20	μA
Input Current	"H" Level	I_{IH}	$V_{IH}=12.0V$, All input terminal	—	—	0.1	μA
	"L" Level	I_{IL}	$V_{IL}=0V$, All input terminal	-0.1	—	—	μA
Input Current Threshold Voltage	V_{I-th}	—	All input terminal	—	—	3.0	V
Output Current	"L" Level	I_{OL}	$V_{DS}=1.0V$, Out=1~6	20	—	—	mA
	"H" Level	I_{OH}	$V_{DS}=1.0V$, KS terminal	—	—	-1.0	mA
	"L" Level	I_{OL}	$V_{DS}=1.0V$, KS terminal	1.0	—	—	mA
	"H" Level	I_{OH}	$V_{DS}=16V$, Out=1~6	—	—	1.0	μA

Characteristic of Output Buffer Transistor (Reference)

Characteristic of V_{DS} to I_{DD} at the time when V_{GS} is taken as parameter (Reference value).

* This IC is equivalent to $V_{GS}=V_{DD}$, and V_{DS} is the remaining voltage of output.

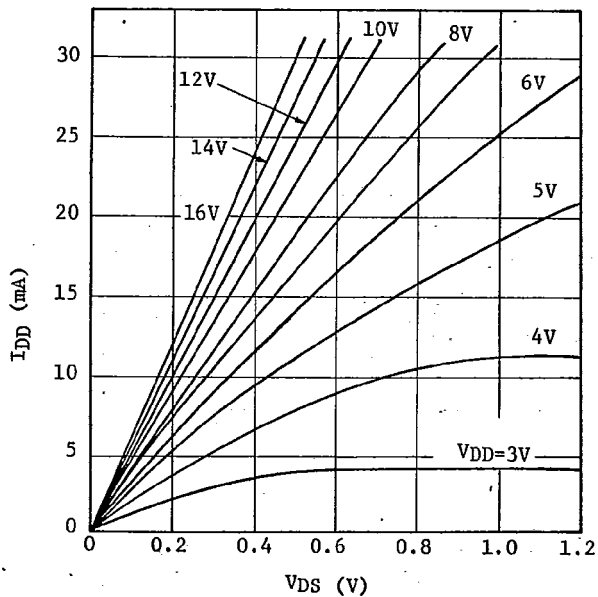

TEST CIRCUIT

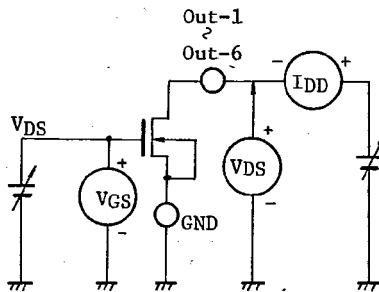

AUDIO DIGITAL IC

TC9135P

T-65-05

FUNCTIONAL EXPLANATION OF TERMINALS

PIN NO.	SYMBOL	TERMINAL NAME	FUNCTION
15 7 10	IN-1 ? IN-6	Input signal Terminals	When volatage applied to either one of 1 ~ 6 terminal is changed from "H" to "L" level, Nch FET of corresponding output is turned ON and other outputs are turned OFF. It is thus possible to correspond to both the feather-touch system by measures of a mechanical key and the touch switch by means of a touch sensor.
2 ? 7	Out-1 ? Out-6	Output Terminals	When corresponding input terminals are changed to "L" level, output Nch FET is turned ON and output level becomes "L" level. Even when input signal is returned to "H" level, output is kept at "L" level, but it is released if input is applied to other channels, and Nch FET is turned OFF and output is turned to an open state. As max 30mA of current can be applied to output Nch FET, it is possible to directly drive LED's and small size relays.
9	KS	Input Detection signal	KS output becomes "H" level only during the period when "L" level signal is given to input to either IN-1 ~ IN-6.
8	6/3	6ch/3ch x 2 switching input terminal	When this terminal is at "H" level, the internal 6-circuit flip-flops are all connected as mutual reset type. When it is at "L" level, the flip-flops are separated to 3ch mutual reset types; IN-1 ~ IN-3 and IN-4 ~ IN-6.
16	VDD		
-1	GND		

TOSHIBA

TC9135P

T-65-05

BLOCK DIAGRAM

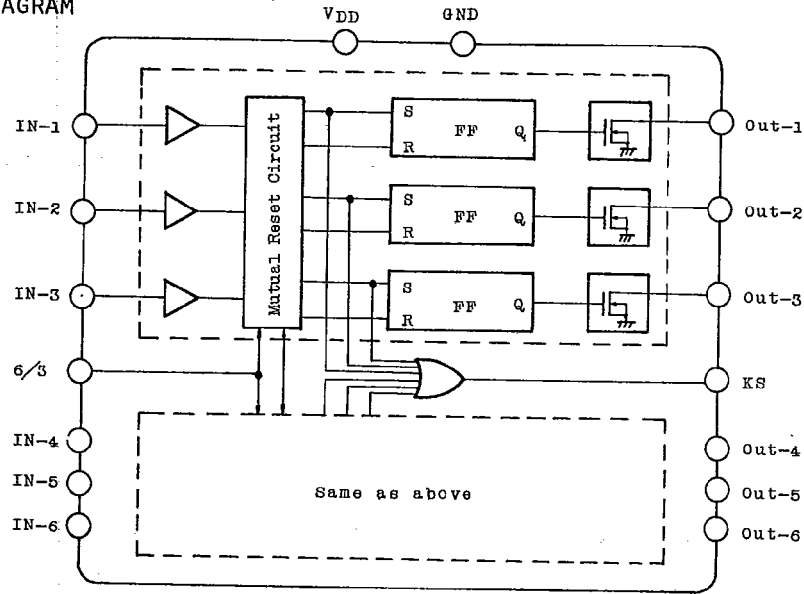

EXAMPLES OF APPLICATION CIRCUIT

1. INPUT CIRCUIT

a. Feather-touch key system

b. Touch sensor system

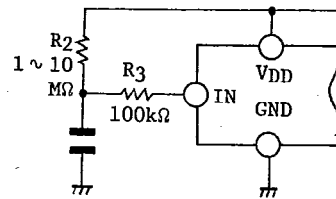
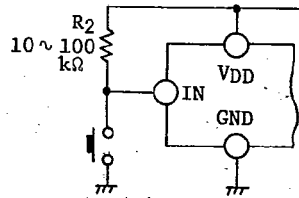

- * If an erroneous operation is a problem in a noisy equipment, a condenser of small capacity should be connected between IN and GND
- * R_2 should be decided with specification of sensor sensitivity, V_{DD} voltage, et.
- * R_3 is a static voltage breakdown protective resistor.

AUDIO DIGITAL IC

TC9135P

T-65-05

2. OUTPUT CIRCUIT

The output circuit is of Nch FET open drain type, capable of leading in current up to 30mA, and is able to directly drive LED's and relays.

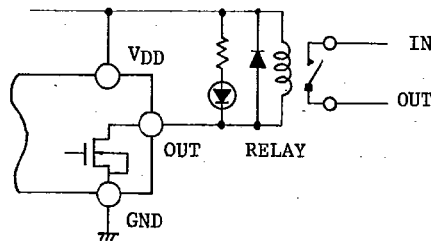

- * Drive current should be limited to 30mA per output terminal.
- * In the event using supply voltage is low, current capacity of output FET also drops and current up to 30mA may not be applied.
(See the graph.)

When signal level only is required without driving LED's and relays, a load resistance must be connected between Out-V_{DD}.

3. STATUS BACK-UP

Current consumption of TC9135P itself is as very small as 10 μ A, max., and V_{DD} is operable up to 3V. Therefore, by providing a condenser to power supply, status back-up for an extended period of time is possible.

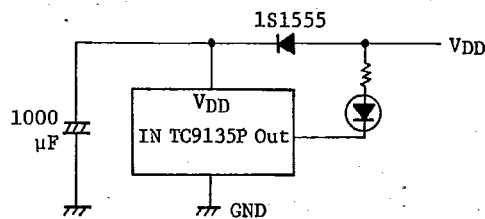

TOSHIBA

TC9135P

T-65-05

4. INITIALIZATION AT TIME POWER IS TURNED ON

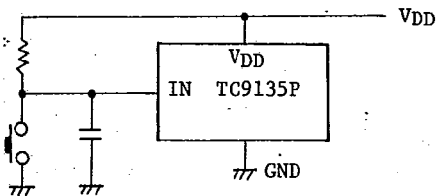
If the initialization of a specific channel is desirable at time power is turned ON, the initialization is possible by connecting a condenser of small capacity to the input to a desired channel.



AUDIO DIGITAL IC