

# TC9143P, TC9144P

T-17-21

## FOR TAPE DECK CONTROL

TC9143P/TC9144P are C-MOS IC for electro-mechanical control of cassette tape deck by a soft touch switch with various functions making the most of electronic features.

- Non-Lock type input key is usable. Mechanical control in desired mode is possible by placing input at "H" level instantaneously.
- Direct change among all operation mode is possible, mode change is effected automatically through stop mode as required.
- Multi-pushing of input keys and other measures incorporated for preventing erroneous operation.
- In set under STOP mode at time of power ON.
- Input terminals are in I/O construction and direct illumination of operating mode LED's is possible. This allows mode display on the wired remote control switch box.
- The driving bipolar transistor housed in each output terminal provides large current capacity, makes the motor or solenoid driving easy, and allows direct illumination of the operating mode display LED's.
- The built-in tape running detecting timer assures easy formation of a tape running.
- TC9143P has the control function for PAUSE TO PAUSE and TC9144P has that for PAUSE TO PLAY.

### MAXIMUM RATINGS ( Ta=25°C )

CHARACTERISTIC	SYMBOL	RATING	UNIT
Supply Voltage	VDD	12	V
Input Voltage	VIN	-0.3~VDD+0.3	V
Output Current	I <sub>OUT</sub>	30	mA
Power Dissipation	P <sub>D</sub>	300	mW
Operating Temperature	T <sub>opr</sub>	-30 ~ 75	°C
Storage Temperature	T <sub>stg</sub>	-55 ~ 125	°C

Unit in mm

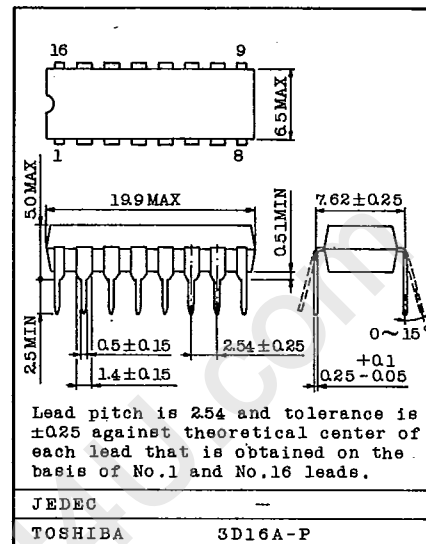

### PIN CONNECTIONS

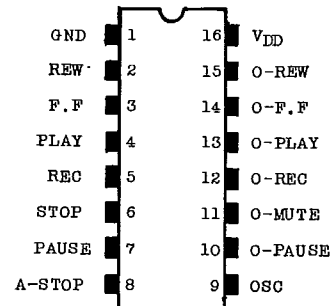

**TOSHIBA**

# TC9143P, TC9144P

T-77-21

ELECTRICAL CHARACTERISTICS (Unless otherwise specified,  $T_a=25^\circ\text{C}$ ,  $V_{DD}=8\text{V}$ )

CHARACTERISTIC		SYMBOL	TEST CIRCUIT	TEST CONDITION	MIN.	TYP.	MAX.	UNIT
Operating Supply Voltage		$V_{DD}$	-	All operations are possible.	4.5	-	10	V
Operating Supply Current		$I_{DD}$	-	After no load STOP	-	-	1.0	mA
Input Voltage	"H" Level	$V_{IH}$	-	All input terminals	5.6	-	$V_{DD}$	V
	"L" Level	$V_{IL}$	-		0	-	2.4	
Output Current	"H" Level	$I_{OH}$	-	Bipolar Output $V_{OH}=6.8\text{V}$	15	20	-	mA
	"H" Level	$I_{OH}$	-	C-MOS Output	$V_{OH}=6\text{V}$	1.0	-	
	"L" Level	$I_{OL}$	-		$V_{OH}=2\text{V}$	1.0	-	
Input Current	"H" Level	$I_{IH}$	-	A-STOP Input	$V_{IH}=8\text{V}$	-	-	1.0
	"L" Level	$I_{IL}$	-		$V_{IL}=0\text{V}$	-	-	1.0
Hysteresis Width		$V_{HIS}$	-		-	2.0	-	V
Pull-down Resistor		$R_{DOWN}$	-	Except for STOP and A-STOP Inputs	10	-	30	$\text{k}\Omega$
Pull-up Resistor		$R_{UP}$	-	STOP Input	20	-	60	$\text{k}\Omega$
Max. Operating Frequency		$f_{MAX.}$	-	OSC Oscillation Frequency	10	-	-	kHz
Min. Load Resistance		$R_X \text{ MIN.}$	-	OSC Terminal	Resistance	12	-	-
Max. Load Capacity		$C_X \text{ MAX.}$	-	Load		Capacity	-	-

AUDIO DIGITAL IC

# TC9143P, TC9144P

T-77-21

## BLOCK DIAGRAM

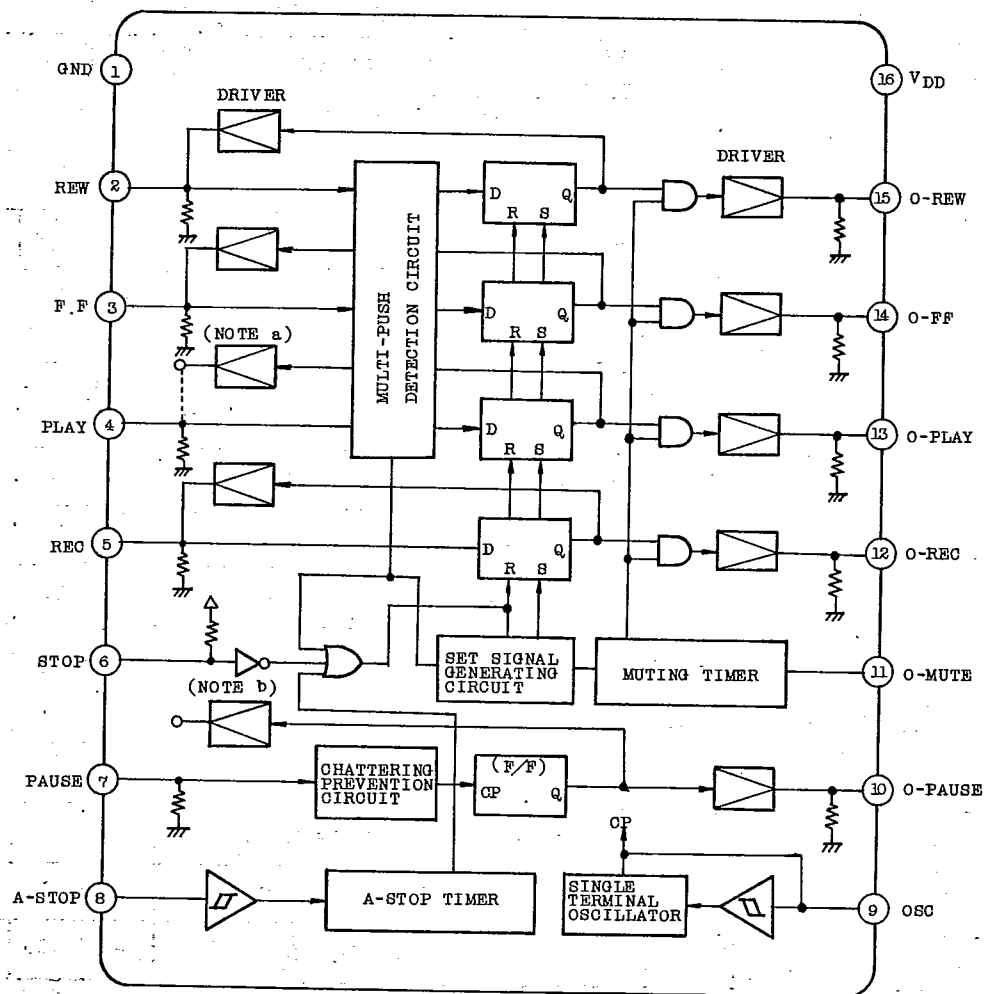

Note : Above diagram is the block diagram of TC9143P.

In the case of TC9144P, the output terminal of DRIVER (Note a) is opened, and the output terminal of DRIVER (Note b) is connected to PAUSE input terminal.

TOSHIBA

# TC9143P, TC9144P

T-77-21

PIN NAMES & DESCRIPTION

PIN NO.	NAME	FUNCTION	NOTE
1	GND	Earth Terminal	-
2	REW	Rewind command input	1
3	F.F	Fast forward command input	1
4	PLAY	Record command input by simultaneous pushing PLAY and REC Keys.	1
5	REC	Record command input by simultaneous pushing Source Monitor and PLAY Keys.	1
6	STOP	Operation stop command input	2
7	PAUSE	PLAY pause (TC9143/44P) and release command input (TC9143P)	1
8	A-STOP	Input terminal for tape running stop	3
9	OSC	Input terminal for timing generation	4
10	O-PAUSE	Output in PAUSE mode	5
11	O-MUTE	Output for fixed time at time of mode change	6
12	O-REC	Output in REC mode	5
13	O-PLAY	Output in PLAY and REC modes	5
14	O-FF	Output in F. FWD mode	5
15	O-REW	Output in REW mode	5
16	VDD	Power Supply terminal	-

INTERNAL EQUIVALENT CIRCUIT IN EACH TERMINAL

NOTE - 1

[Those shown in ( ) indicate KEY(s) of TC9144P]

(I/O Port)

REW, F.F, PLAY, REC (REW, F.F, PAUSE, REC)

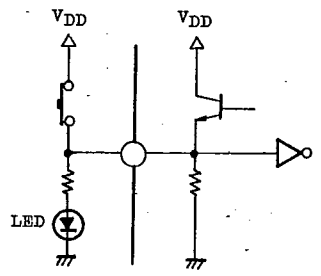

Input terminals serve as I/O ports. When a command is executed by "H" input, "H" level is kept till the mode is changed to other modes. Therefore, it is possible to use for mode display.

Note : As PAUSE (PLAY) input terminal has no driver, "H" level is not retained even when a command is executed by "H" input.

# TC9143P, TC9144P

T-77-21

NOTE - 2

(Input Port)

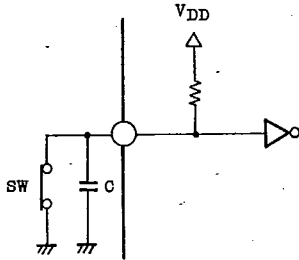

As a pull-up resistor is housed in STOP input, a command is executed by "L" Level. Initialization is executed by externally mounted Capacitor when power is turned on.

NOTE - 3

(Schmid Trigger Input Port)

• A-STOP Input

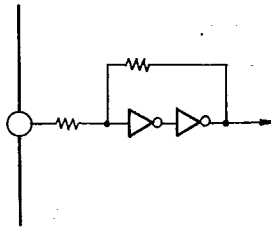

NOTE - 4

(Oscillation I/O Port)

• OSC Terminal

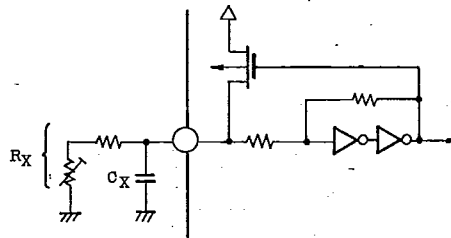

NOTE - 5

(Bipolar Output Port)

• O-REW/F.F/PLAY  
• O-REC/PAUSE

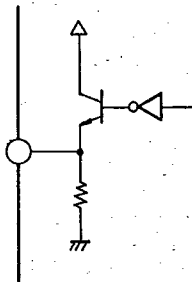

NOTE - 6

(C-MOS Output Port)

• O-MUTE

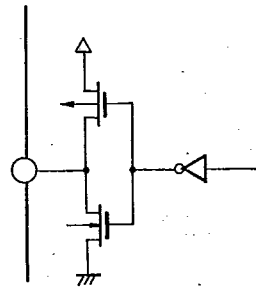

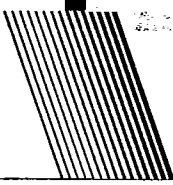

# TC9143P, TC9144P

T-77-21

STATE OF OUTPUT TERMINALS AGAINST KEY INPUTS

○ mark → "H" Output

KEY INPUT \ OUTPUT		O-F.F	O-REW	O-PLAY	O-REC	O-MUTE	O-PAUSE	MODE DESIGNATION
		STOP					○	
F.F	○					○		F. FWD
REW			○			○		REWIND
PLAY				○				PLAY BACK
REC					○			MONITOR
REC/PLAY				○	○			RECORD
P A U S E	STOP					○	○	PAUSE
	PLAY			○		○	○	PLAY PAUSE
	REC				○		○	MONITOR PAUSE
	REC/PLAY			○	○		○	RECORD PAUSE
A-STOP					○		AUTO SHUT-OFF	

OPERATIONS FOR KEY MULTI-PUSHING

KEY INPUT-1	OTHER KEY INPUTS	OUTPUT MODE
STOP	REW, F.F, PLAY, REC, PAUSE	STOP
F.F	REW, PLAY	STOP
	REC, PAUSE	F. FWD
REW	F.F, PLAY	STOP
	REC, PAUSE	REWIND
PLAY	PAUSE	PLAYBACK PAUSE
REC	PLAY	RECORD
	PAUSE	MONITOR PAUSE
	PLAY, PAUSE	RECORD PAUSE

AUDIO DIGITAL IC

# IC9143P, TC9144P

T-77-21

## OPERATIONS AGAINST OPERATING KEY

Those shown in ( ) indicate the operation(s) of TC9144P.

KEY INPUT PRESENT MODE	STOP	F. F	REW	PLAY	REC	REC/PLAY	PAUSE
STOP	-	F. FWD	REWIND	PLAYBACK	MONITOR	RECORD	PAUSE
F. FWD	STOP	-	* REWIND	* PLAYBACK	-	* RECORD	-
REWIND	STOP	* F. FWD	-	* PLAYBACK	-	* RECORD	-
PLAYBACK	STOP	* F. FWD	* REWIND	-	-	-	PLAYBACK PAUSE
MONITOR	STOP	F. FWD	REWIND	PLAYBACK	-	RECORD	MONITOR PAUSE
RECORD	STOP	* F. FWD	* REWIND	-	-	-	RECORD PAUSE
PAUSE	STOP	F. FWD	REWIND	PLAYBACK PAUSE (PLAYBACK)	MONITOR PAUSE	RECORD PAUSE (RECORD)	STOP ( - )
PLAYBACK PAUSE	STOP	* F. FWD	* REWIND	- (PLAYBACK)	-	- (PLAYBACK)	PLAYBACK ( - )
MONITOR PAUSE	STOP	F. FWD	REWIND	PLAYBACK PAUSE (PLAYBACK)	-	RECORD PAUSE (RECORD)	MONITOR ( - )
RECORD PAUSE	STOP	F. FWD	REWIND	(RECORD)	-	- (RECORD)	RECORD ( - )

- (Note)
1. Change of mode with \* mark is executed by way of stop mode in 0.4 sec.
  2. REC/PLAY of KEY input means that REC·KEY is pushed faster than or simultaneously with PLAY·KEY.
  3. - mark shows that current operation mode does not change.
  4. PAUSE release of TC9143P is made by PAUSE·KEY. (PAUSE TO PAUSE)
  5. PAUSE release of TC9144P is made by PLAY·KEY. (PAUSE TO PAUSE)

**TOSHIBA**

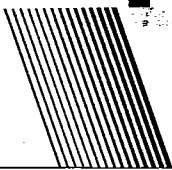

# TC9143P, TC9144P

T-77-21

## METHOD FOR UTILIZING OUTPUT TERMINALS

There are various methods for utilizing output terminals according to mechanisms used in combination. Most basic examples of use are provided here.

### (a) CURRENT CAPACITY OF OUTPUT TERMINAL

All output terminals except O-MUTE (Note) employ bipolar transistor emitter output and current up to 30mA can be obtained at "H" Level output. Therefore it is possible to drive motor and solenoid driving power transistors directly and number of externally mounted parts is minimized. Further, it is also possible to drive the operation mode displaying LED's and Lamps directly.

(Note) Including I/O port input terminal.

### (b) EXAMPLES OF CORRESPONDENCE OF OUTPUT TERMINALS MECHANISMS

PIN NO.	PIN NAME	CONNECTING DRIVER (OTHERS)
13	O-PLAY	Driver for play solenoid (Play Indicator Lamp)
12	O-REC	Driver for Record Solenoid (Record Indicator Lamp)
10	O-PAUSE	Driver for Pause Solenoid(Pause Indicator Lamp)
11	O-MUTE	Driver for Audio Amp Muting
15 14	O-REW O-F.F	} Driver for Driving Reel Motor { (REW Indicator Lamp) (F.F Indicator Lamp)



# TC9143P, TC9144P

T-77-21

## OPERATION TIMING OF OUTPUT TERMINALS TO KEY INPUTS

### (a) Muting Timer operation (O-MUTE Terminal)

The muting timer is used to damp a "Hollow Sound" generated when operation mode is changed by shutting off output from the audio amplifier when the operation mode is changed by KEY Input. Length of this muting time is 0.1 sec when actuated in Stop mode and 0.5 sec at time of direct change (However, as 0.4 sec for the auto Stop is involved, the muting time is 0.1 sec).

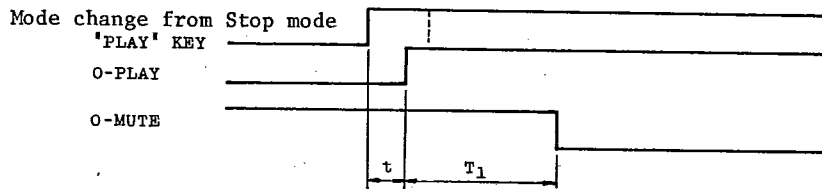

$$t : \text{Chattering Prevention time} = \frac{2}{f_{OSC}} \approx 25 \text{ msec}, f_{OSC} = 80 \text{ Hz}$$

$$T_1 : \text{Muting time} = \frac{8}{f_{OSC}} \approx 100 \text{ msec}, f_{OSC} = 80 \text{ Hz}$$

### (b) MODE CHANGE FROM OTHER MODES EXCEPT STOP MODE (Direct Change)

At time of direct change, mode change is effected by way of Stop Mode for 0.4 sec automatically for tape protection.

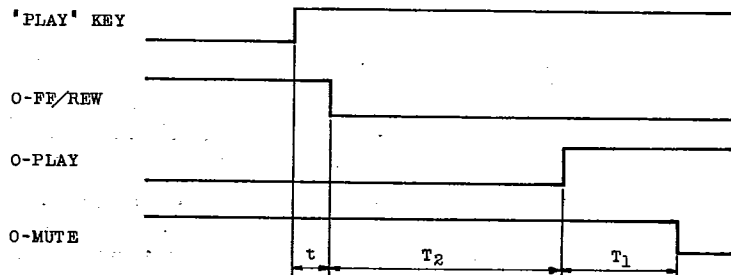

$$t : \text{Chattering prevention time} = \frac{2}{f_{OSC}} \approx 25 \text{ msec}, f_{OSC} = 80 \text{ Hz}$$

$$T_1 : \text{Muting time} = \frac{8}{f_{OSC}} \approx 100 \text{ msec}, f_{OSC} = 80 \text{ Hz}$$

$$T_2 : \text{Stop Mode time} = \frac{32}{f_{OSC}} \approx 0.4 \text{ sec}, f_{OSC} = 80 \text{ Hz}$$

# TC9143P, TC9144P

T-77-21

## (c) A-STOP INPUT

A-STOP Input has the function to detect the end of tape running and automatically change operation mode to STOP mode. (AUTO SHUT OFF)

As A-STOP Input has a built in timer operation mode is changed to STOP mode after about 0.8 sec when A-STOP Input is changed from "H" Level to "L" Level.

Further, A-STOP Input is operable either by AC or DC input as shown below.

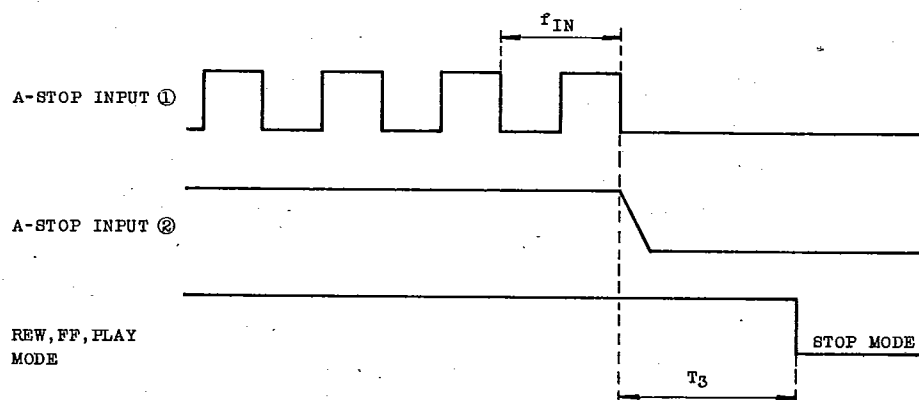

A-STOP ① shows reel turning signal amplified and directly input.

However, input frequency shall be more than 1.25 Hz.

A-STOP ② shows above signal after rectified.

$$T_3 = \frac{64}{f_{OSC}} \text{ (sec)} \approx 0.8 \text{ sec, } f_{OSC} = 80 \text{ Hz}$$

$$f_{IN} \geq \frac{f_{OSC}}{64} \text{ (Hz)} \approx 1.25 \text{ Hz, } f_{OSC} = 80 \text{ Hz}$$

# TC9143P, TC9144P

T-77-21

## EXAMPLE OF APPLICATION CIRCUIT

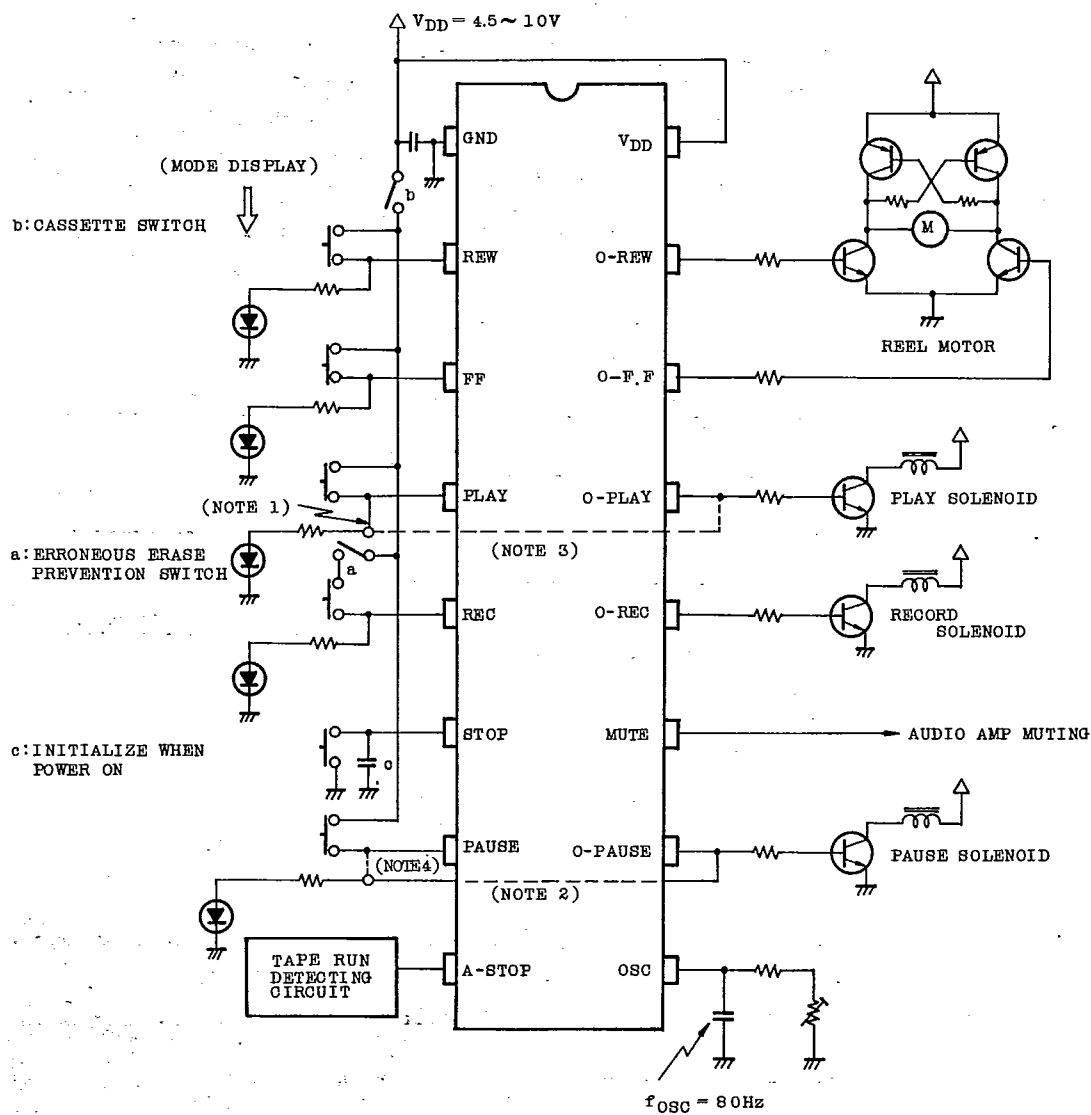

Note : Shown in above diagram is an example of application of TC9143P.  
In the case of TC9144P, the leads (Note 1 and 2) in the diagram  
are opened and leads (Note 3 and 4) are connected.

TOSHIBA

# TC9143P, TC9144P

T-77-21

## CAUTIONS IN APPLICATION

### (1) Method for determining C and R constants of OSC Terminal

a. When oscillation frequency is  $f_{OSC}$ , internal operation time is set as follows :

\* Chattering prevention time  $t = \frac{1}{f_{OSC}} \sim \frac{2}{f_{OSC}}$  (sec)

\* Muting time  $T_1 = \frac{8}{f_{OSC}}$  (sec)

\* Direct change auto stop time  $T_2 = \frac{32}{f_{OSC}}$  (sec)

\* Tape run detection timer time  $T_3 = \frac{64}{f_{OSC}}$  (sec)

Therefore, operation time can be optionally selected according to the mechanisms used.

a. As oscillation frequency may vary depending upon IC, it is adequate to use a semi-fixed resistor. Refer to Graph (1) and (2).

### (2) Method for initializing (Stop mode) at time of power on.

\* Initialization is possible when a capacitor is connected to Stop Terminal (6 pin) as illustrated below. Warm-up time is determined by internal pull-up resistors ( $20 \sim 60k\Omega$ ) and time constant of the externally mounted capacitor "C".

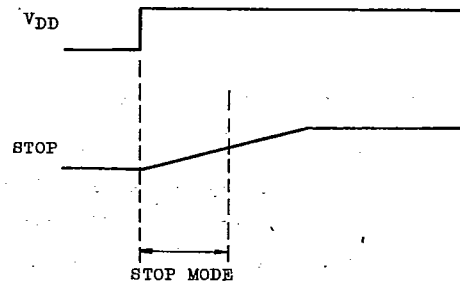
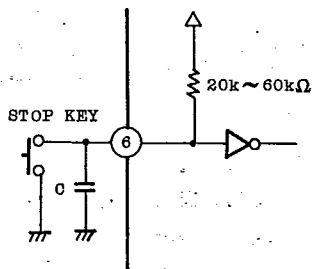

AUDIO DIGITAL IC

# TC9143P, TC9144P

T-77-21

### (3) Addition of cassette switch function

To reject all operating key inputs and to keep a cassette deck in stop mode when cassette tape isn't loaded, a cassette switch shall be connected as shown below.

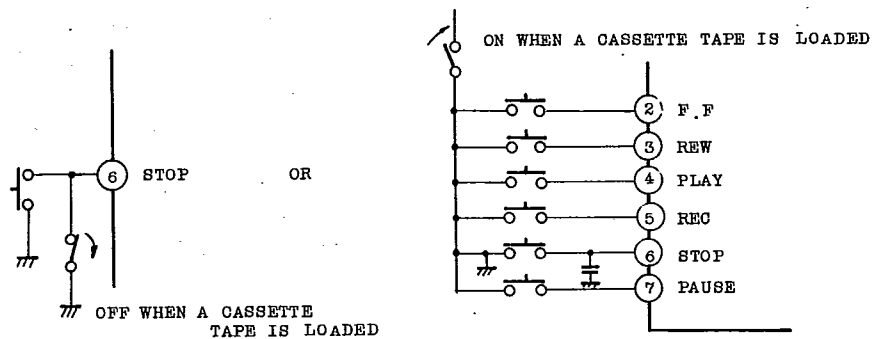

### (4) Addition of erroneous erase preventing function

Any cassette tape has a tab for preventing erroneous erasing. The erroneous erase preventing function can be added by connecting a switch for detecting this tab as shown below.

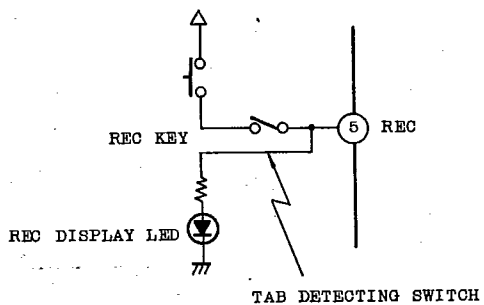

### (5) Remote control function

As one of features of electronic control system, the remote control function can be easily realized. This IC is also capable of displaying mode on the remote control box. To prevent large current from flowing to the remote control wire, it is considered appropriate to additionally provide a buffer transistor as illustrated.

# TC9143P, TC9144P

T-77-21

## TC9143P : EXAMPLES OF APPLICATION CIRCUIT

Body switch/Display

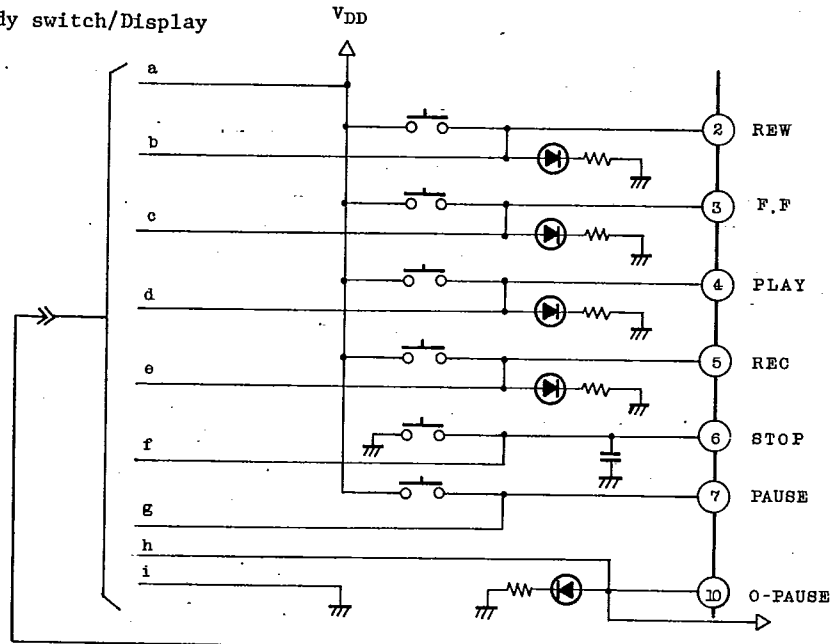

Remote-Control Box Switch/Display

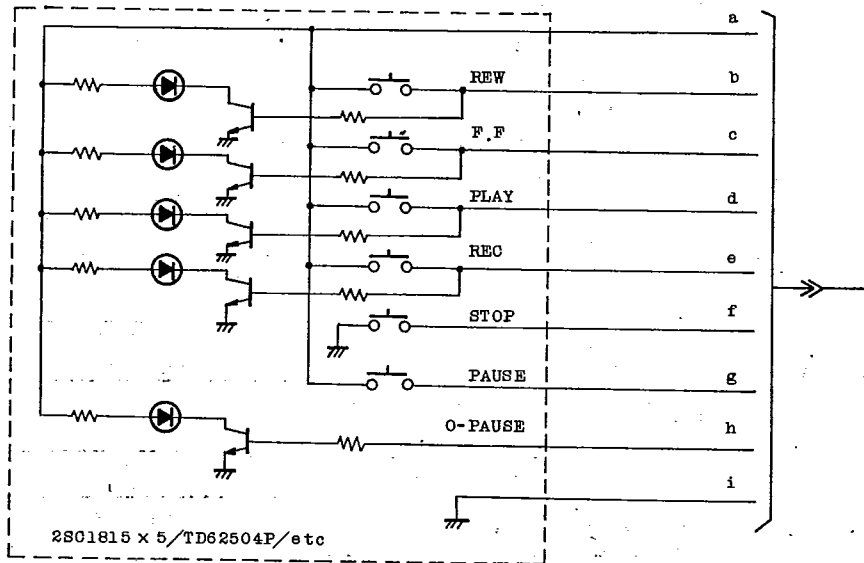

AUDIO DIGITAL IC

# TC9143P, TC9144P

T-77-21

## TC9144P : EXAMPLES OF APPLICATION CIRCUIT

Body switch/Display

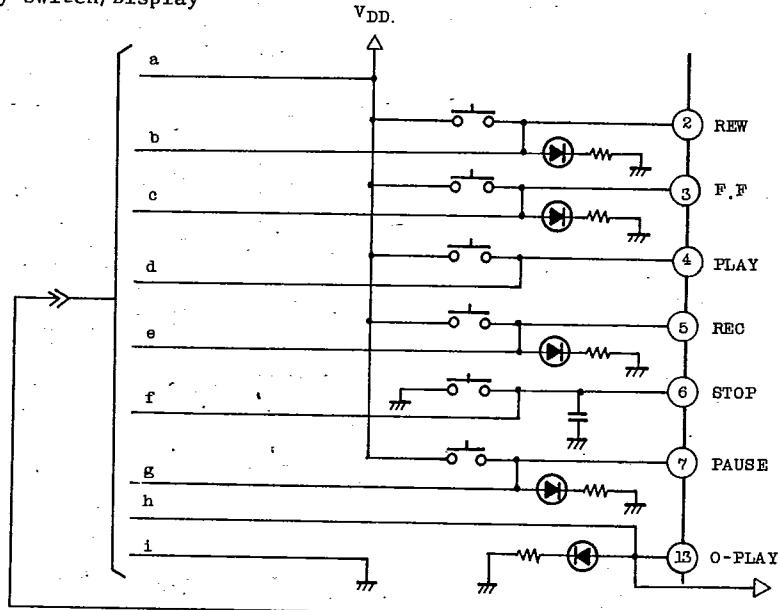

Remote Control Box Switch/Display

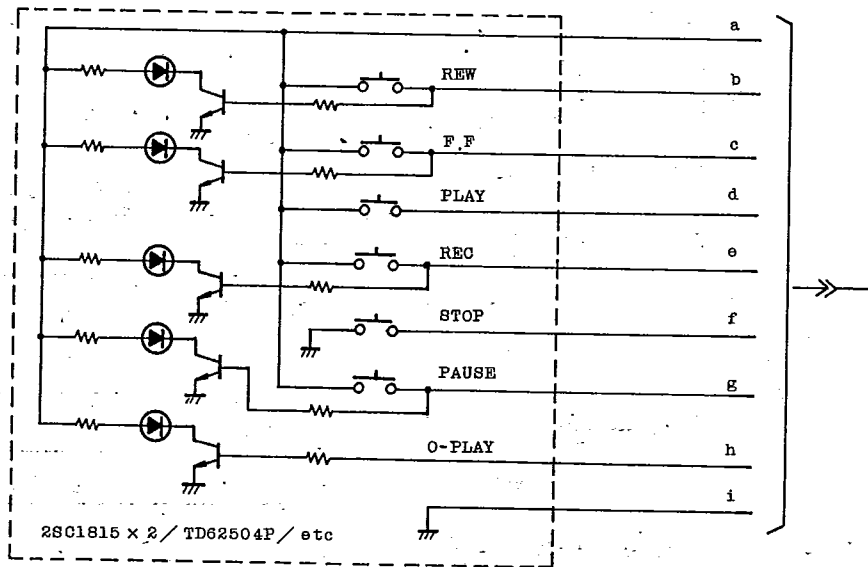

# TC9143P, TC9144P

T-77-21

(6) Mechanical type counter with memory connecting method

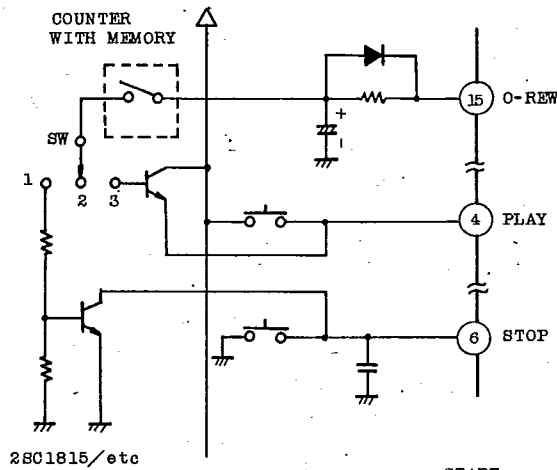

SW : 1 Memory Stop  
2 OFF  
3 Memory Play

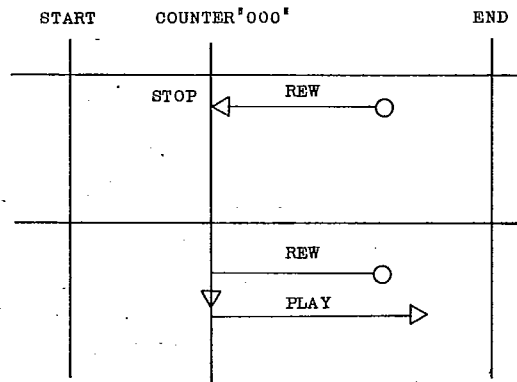

(Note) Switch ON time of the counter with memory should be longer than chattering preventing time ( $t=2/f_{OSC}$  (sec)).  
(When memory play is used)

(7) A-STOP Signal Generating method

A-STOP signal shall be such a signal that becomes "H" level when a type is running, "L" level when stopping, or AC signal when a tape is running (input frequency  $\geq f_{OSC}/64$ ) and "L" level when stopping.



# TC9143P, TC9144P

T-77-21

Example-1 (When a photo-transistor is used)

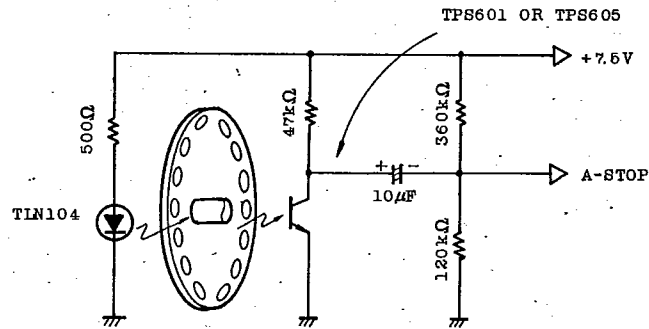

Example-2 (When a hole element is used)

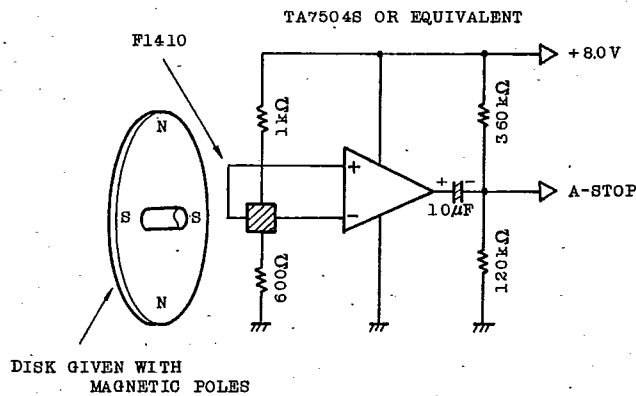

(Note) Number of slits of the reel rotation detecting disk (Example-1) and Number of magnetic poles (Example-2) should be so set that oscillation frequency becomes more than  $f_{OSC}/64$  (Hz) even when the reel rotation drops to the min. speed.

# TC9143P, TC9144P

T-77-21

GRAPH (1) OSC TERMINAL OSCILLATION CHARACTERISTICS

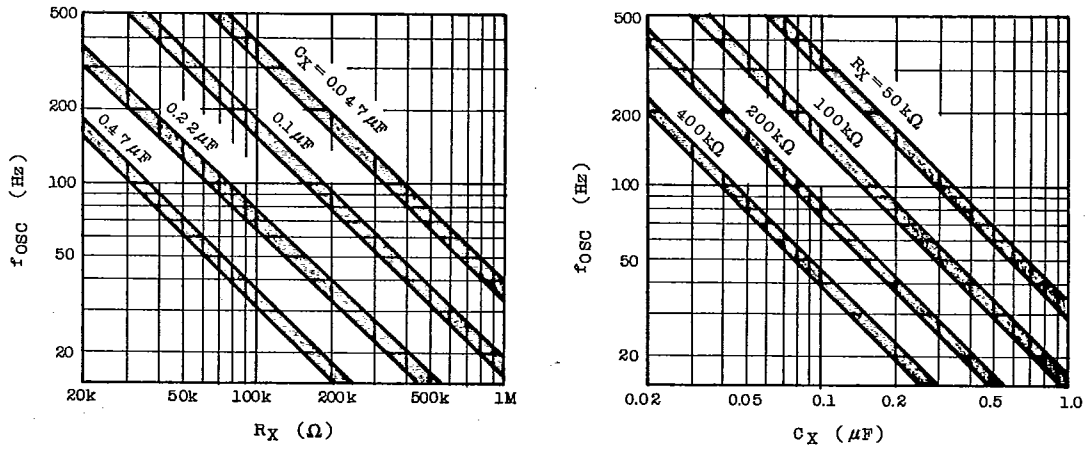

TEST CIRCUIT  $V_{DD} = 8.0V$

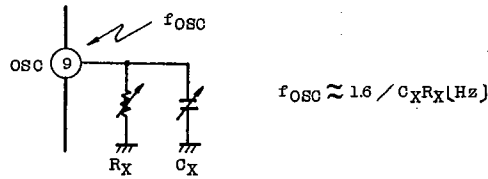

GRAPH (2) OSC TERMINAL SUPPLY VOLTAGE CHARACTERISTICS

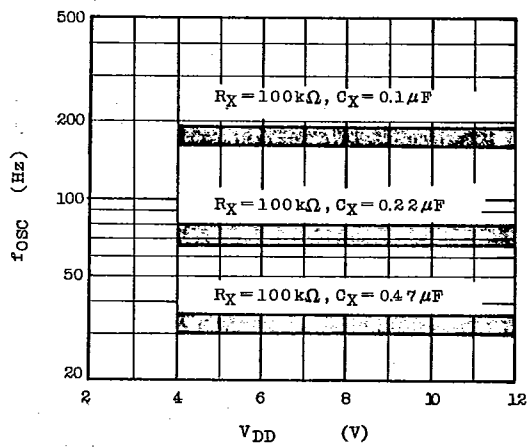

TEST CIRCUIT

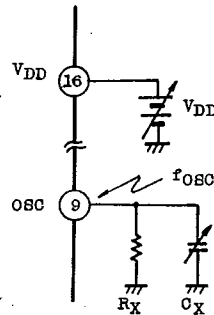

AUDIO DIGITAL IC