

TOSHIBA CMOS Digital Integrated Circuit Silicon Monolithic

TC9495F

Digital Servo Single Chip Processor Built in 1 Bit DA Converter

The TC9495F is a single chip processor which incorporates the following function: synchronous separation protection and interpolation, EFM demodulation, Error correction, micro controller interface, digital equalizer for use in servo LSI and servo control circuit.

In addition, the TC9495F incorporates a 1 bit DA converter. In combination with the head amplifier TA2109F, TA2150FN, TA2153FN for digital servo, the TC9495F allow simplified, adjustment-free structuring of CD player system.

Features

- Capable of decode the text data.
- Sync pattern detection, sync signal protection and synchronization can be made correctly.
- Built in EFM demodulation circuit, subcode demodulation circuit.
- Capable of correcting dual C₁ correction and quadruple C₂ correction using the CIRC correction theoretical format.
- The TC9495F respond to variable playback system.
- Jitter absorbing capacity of ± 6 frames.
- Built in 16 KB RAM.
- Built in digital out circuit.
- Built in L/R independent digital attenuator.
- Audio output responds to bilingual function.
- Reed timing free subcode Q data and capable of synchronous output with audio data.
- Built in data slicer and analog PLL (free-adjustment VCO).
- Capable of automatic adjustment function of focus servo and tracking servo, for loop gain, offset and balance.
- Built in RF gain automatic adjustment circuit.
- Built in digital equalizer for phase compensation.
- Built in RAM for digital equalizer for coefficient, and capable of variable pickup.
- Built in focus, tracking servo control circuit.
- Search control corresponds to every mode and can realize high speed and stable search.
- Lens-kick and feed-kick are using speed controlled form.
- Built in AFC circuit and APC circuit for CLV servo of disc motor.
- Built in anti-defect and anti-shock circuit.
- Built in 8 times over sampling digital filter and 1 bit DA converter.
- Built in analog filter for 1 bit DA converter.
- Output format for audio out can be selected 32 fs, 48 fs, or 64 fs modes.
- Built in zero data detect output circuit.
- The TC9495F capable of 4 times speed operation.
- Built in micro controller interface circuit.
- CMOS silicon structure and high speed, low power consumption.
- 100 pin flat package.

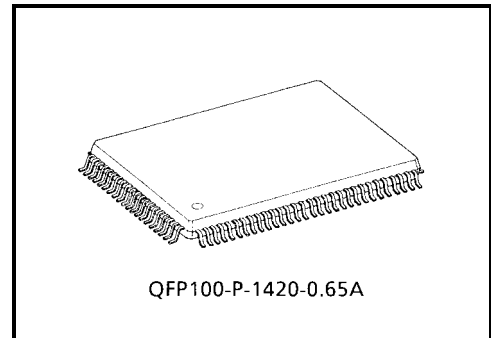

Weight: 1.6 g (typ.)

Block Diagram (top view)

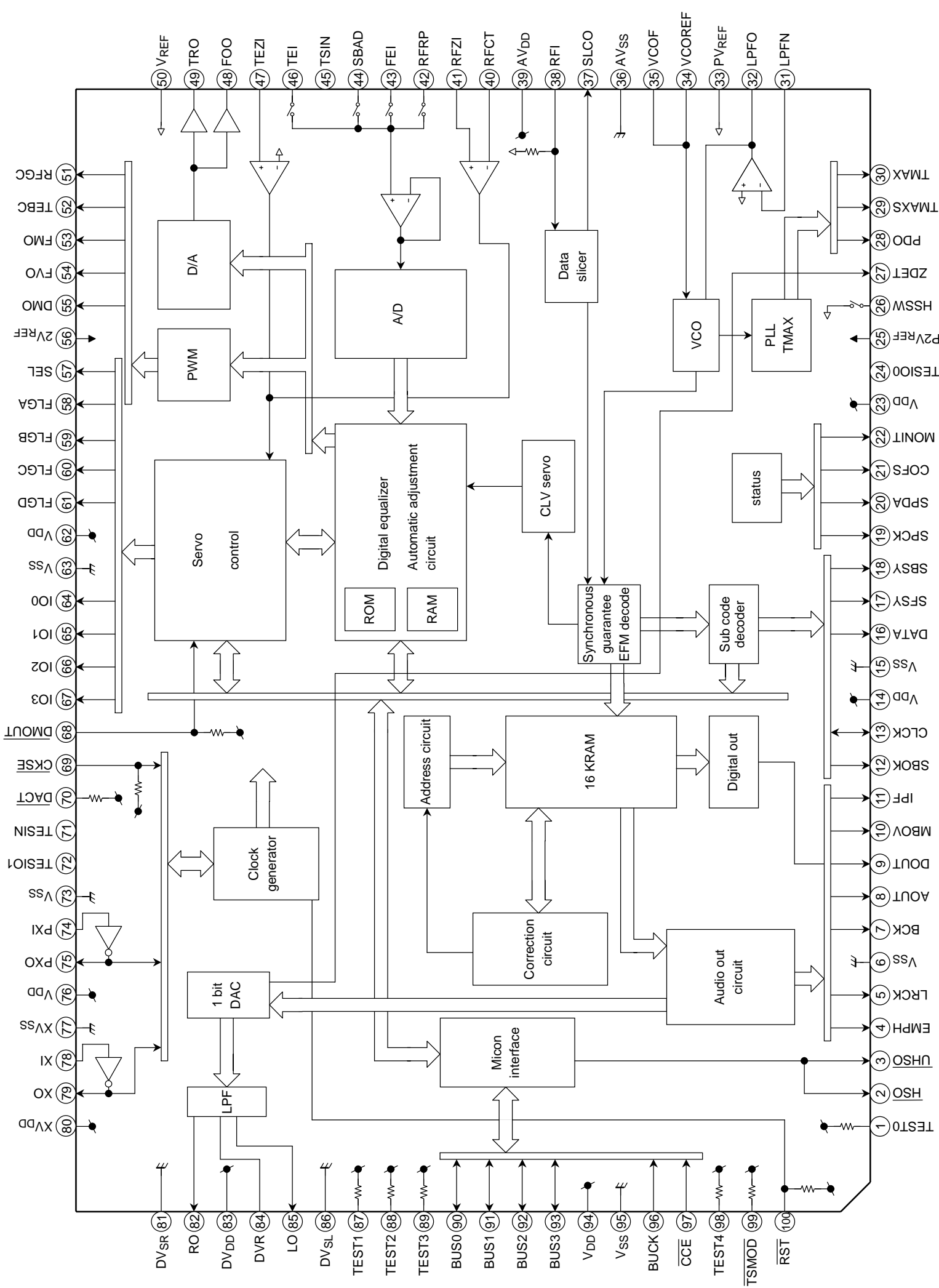

Pin Function

Pin No.	Symbol	I/O	Functional Description	Remarks															
1	TEST0	I	Test mode terminal. Normally, keep at open.	With pull-up resistor.															
2	$\overline{\text{HSO}}$	O	Playback speed mode flag output terminal.	—															
3	$\overline{\text{UHSO}}$	O	<table border="1"> <thead> <tr> <th>$\overline{\text{UHSO}}$</th> <th>$\overline{\text{HSO}}$</th> <th>Playback Speed</th> </tr> </thead> <tbody> <tr> <td>H</td> <td>H</td> <td>Normal</td> </tr> <tr> <td>H</td> <td>L</td> <td>2 times</td> </tr> <tr> <td>L</td> <td>H</td> <td>4 times</td> </tr> <tr> <td>L</td> <td>L</td> <td>—</td> </tr> </tbody> </table>		$\overline{\text{UHSO}}$	$\overline{\text{HSO}}$	Playback Speed	H	H	Normal	H	L	2 times	L	H	4 times	L	L	—
			$\overline{\text{UHSO}}$		$\overline{\text{HSO}}$	Playback Speed													
			H		H	Normal													
			H	L	2 times														
L	H	4 times																	
L	L	—																	
4	EMPH	O	Subcode Q data emphasis flag output terminal. Emphasis ON at "H" level and OFF at "L" level. The output polarity can invert by command.																
5	LRCK	O	Channel clock output terminal. (44.1 kHz) L-ch at "L" level and R-ch at "H" level. The output polarity can invert by command.																
6	V _{SS}	—	Digital GND terminal.	—															
7	BCK	O	Bit clock output terminal. Output is selectable 1.4112 MHz, 2.1168 MHz or 2.8224 MHz.	—															
8	AOUT	O	Audio data output terminal.	—															
9	DOUT	O	Digital data output terminal.	—															
10	MBOV	O	Buffer memory over signal output terminal. Over at "H" level.	—															
11	IPF	O	Correction flag output terminal. At "H" level, AOUT output is made to correction impossibility by C ₂ correction processing.	—															
12	SBOK	O	Subcode Q data CRCC check adjusting result output terminal. The adjusting result is OK at "H" level.	—															
13	CLCK	I/O	Subcode P~W data readout clock input/output terminal. This terminal can select by command bit.	—															
14	V _{DD}	—	Digital power supply voltage terminal.	—															
15	V _{SS}	—	Digital GND terminal.	—															
16	DATA	O	Subcode P~W data output terminal.	—															
17	SFSY	O	Play-back frame sync signal output terminal.	—															
18	SBSY	O	Subcode block sync signal output terminal.	—															
19	SPCK	O	Processor status signal readout clock output terminal.	—															
20	SPDA	O	Processor status signal output terminal.	—															
21	COFS	O	Correction frame clock output terminal. (7.35 kHz)	—															
22	MONIT	O	Internal signal (DSP internal flag and PLL clock) output terminal. Selected by command. This terminal output the text data with serial by command.	—															
23	V _{DD}	—	Digital power supply voltage terminal.	—															
24	TESIO0	I	Test input/output terminal. Normally, keep at "L" level. The terminal that inputted the clock for read of text data by command.	—															

Pin No.	Symbol	I/O	Functional Description	Remarks								
25	P2VREF	—	PLL double reference voltage supply terminal.	—								
26	HSSW	O	2/4 times speed at "VREF" voltage.	2-state output. (PVREF, HiZ)								
27	ZDET	O	1 bit DA converter zero detect flag output terminal.	—								
28	PDO	O	Phase difference signal output terminal of EFM signal and PLCK signal.	3-state output. (P2VREF, PVREF, VSS)								
29	TMAXS	O	TMAX detection result output terminal. Selected by command bit (TMPS).	3-state output. (P2VREF, PVREF, VSS)								
30	TMAX	O	TMAX detection result output terminal. Selected by command bit (TMPS).	3-state output. (P2VREF, HiZ, VSS)								
			<table border="1"> <thead> <tr> <th>Difference Result</th> <th>TMAX Output</th> </tr> </thead> <tbody> <tr> <td>Longer than fixed freq.</td> <td>"P2VREF"</td> </tr> <tr> <td>Shorter than fixed freq.</td> <td>"VSS"</td> </tr> <tr> <td>Within the fixed freq.</td> <td>"HiZ"</td> </tr> </tbody> </table>		Difference Result	TMAX Output	Longer than fixed freq.	"P2VREF"	Shorter than fixed freq.	"VSS"	Within the fixed freq.	"HiZ"
			Difference Result		TMAX Output							
			Longer than fixed freq.		"P2VREF"							
Shorter than fixed freq.	"VSS"											
Within the fixed freq.	"HiZ"											
31	LPFN	I	LPF amplifier inverting input terminal for PLL.	Analog input.								
32	LPFO	O	LPF amplifier output terminal for PLL.	Analog output.								
33	PVREF	—	PLL reference voltage supply terminal.	—								
34	VCOREF	I	VCO center frequency reference level terminal. Normally, keep at "PVREF" level.	—								
35	VCOF	O	VCO filter terminal.	Analog output.								
36	AVSS	—	Analog GND terminal.	—								
37	SLCO	O	Data slice level output terminal.	Analog output.								
38	RFI	I	RF signal input terminal.	Analog input. (Z _{in} : selected by command)								
39	AVDD	—	Analog power supply voltage terminal.	—								
40	RFCT	I	RFRP signal center level input terminal.	Analog input. (Z _{in} : 50 kΩ)								
41	RFZI	I	RFRP zero cross input terminal.	Analog input.								
42	RFRP	I	RF ripple signal input terminal.	Analog input.								
43	FEI	I	Focus error signal input terminal.	Analog input.								
44	SBAD	I	Sub-beam adder signal input terminal.	Analog input.								
45	TSIN	I	Test input terminal. Normally, keep at "VREF" level.	Analog input.								
46	TEI	I	Tracking error signal input terminal. Take in at tracking servo on.	Analog input.								
47	TEZI	I	Tracking error zero cross input terminal.	Analog input. (Z _{in} : 10 kΩ)								
48	FOO	O	Focus servo equalizer output terminal.	Analog output. (2VREF~AVSS)								
49	TRO	O	Tracking servo equalizer output terminal.									
50	VREF	—	Analog reference voltage supply terminal.	—								
51	RFGC	O	RF amplitude adjustment control signal output terminal.	3-state output. (2VREF, VREF, VSS)								
52	TEBC	O	Tracking balance control signal output terminal.									
53	FMO	O	Feed equalizer output terminal.	—								
54	FVO	O	Speed error signal or feed search equalizer output terminal.	—								

Pin No.	Symbol	I/O	Functional Description	Remarks
55	DMO	O	Disk equalizer output terminal. (PWM carrier = 88.2 kHz for DSP, Synchronize to PXO)	—
56	2VREF	—	Analog double reference voltage supply terminal.	—
57	SEL	O	APC circuit ON/OFF indication signal output terminal. At the laser on time, UHF = L at "HiZ" level and UHF = H at "H" level.	—
58	FLGA	O	External flag output terminal for internal signal. Can select signal from TEZC, \overline{FOON} , \overline{FOK} and RFZC by command.	—
59	FLGB	O	External flag output terminal for internal signal. Can select signal from \overline{DFCT} , \overline{FOON} , \overline{FMON} and RFZC by command.	—
60	FLGC	O	External flag output terminal for internal signal. Can select signal from \overline{TRON} , \overline{TRSR} , \overline{FOK} and \overline{SRCH} by command.	—
61	FLGD	O	External flag output terminal for internal signal. Can select signal from \overline{TRON} , \overline{DMON} , \overline{HYS} and \overline{SHC} by command.	—
62	VDD	—	Digital power supply voltage terminal.	—
63	VSS	—	Digital GND terminal.	—
64	IO0	I/O	General I/O terminal. Can change over input port or output port by command. At the input mode time can readout a state of terminal (H/L) by read command. At the output mode time can control a state of terminal (H/L/HiZ) by command.	—
65	IO1			
66	IO2			
67	IO3			
68	\overline{DMOUT}	I	This terminal controls IO0~IO3 terminal. At "L" level time, IO0, 1 out feed equalizer signal of 2-state PWM, IO2, 3 out disk equalizer signal of 2-state PWM.	With pull-up resistor.
69	\overline{CKSE}	I	Normally, keep at open.	With pull-up resistor.
70	\overline{DACT}	I	DAC test mode terminal. Normally, keep at open.	With pull-up resistor.
71	TESIN	I	Test input terminal. Normally, keep at "L" level.	Analog input.
72	TESIO1	I	Test input/output terminal. Normally, keep at "L" level.	—
73	VSS	—	Digital GND terminal.	—
74	PXI	I	Crystal oscillator connecting input terminal for DSP. Normally, keep at "L" level.	Analog input.
75	PXO	O	Crystal oscillator connecting output terminal for DSP.	
76	VDD	—	Digital power supply voltage terminal.	—
77	XVSS	—	Oscillator GND terminal for system clock.	—
78	XI	I	Crystal oscillator connecting input terminal for system clock.	—
79	XO	O	Crystal oscillator connecting output terminal for system clock.	—
80	XVDD	—	Oscillator power supply voltage terminal for system clock.	—
81	DVSR	—	Analog GND terminal for DA converter. (R-ch)	—
82	RO	O	R channel data forward output terminal.	—
83	DVDD	—	Analog supply voltage terminal for DA converter.	—
84	DVR	—	Reference voltage terminal for DA converter.	—
85	LO	O	L channel data forward output terminal.	—
86	DVSL	—	Analog GND terminal for DA converter. (L-ch)	—
87	TEST1	I	Test mode terminal. Normal, keep at open.	With pull-up resistor.

Pin No.	Symbol	I/O	Functional Description	Remarks
88	TEST2	I	Test mode terminal. Normal, keep at open.	With pull-up resistor.
89	TEST3	I	Test mode terminal. Normal, keep at open.	With pull-up resistor.
90	BUS0	I/O	Micon interface data input/output terminal.	Schmit input. CMOS port.
91	BUS1	I/O		
92	BUS2	I/O		
93	BUS3	I/O		
94	V _{DD}	—	Digital power supply voltage terminal.	—
95	V _{SS}	—	Digital GND terminal.	—
96	BUCK	I	Micon interface clock input terminal.	Schmit input.
97	$\overline{\text{CCE}}$	I	Command and data sending/receiving chip enable signal input terminal. The bus line becomes active at "L" level.	Schmit input.
98	TEST4	I	Test mode terminal. Normal, keep at open.	With pull-up resistor.
99	$\overline{\text{TSMOD}}$	I	Local test mode selection terminal.	With pull-up resistor.
100	$\overline{\text{RST}}$	I	Reset signal input terminal. Reset at "L" level.	With pull-up resistor.

Maximum Ratings (Ta = 25°C)

Characteristics	Symbol	Rating	Unit
Power supply voltage	V _{DD}	-0.3~6.0	V
Input voltage	V _{IN}	-0.3~V _{DD} + 0.3	V
Power dissipation	P _D	1420	mW
Operating temperature	T _{opr}	-40~85	°C
Storage temperature	T _{stg}	-55~150	°C

Electrical Characteristics

(unless otherwise specified, $V_{DD} = AV_{DD} = DV_{DD} = XV_{DD} = 5\text{ V}$, $2V_{REF} = P2V_{REF} = 4.2\text{ V}$, $V_{REF} = PV_{REF} = 2.1\text{ V}$, $T_a = 25^\circ\text{C}$)

DC Characteristics

Characteristics		Symbol	Test Circuit	Test Condition		Min	Typ.	Max	Unit
Assured supply voltage		V_{DD}	—	$T_a = -40\sim 85^\circ\text{C}$		4.5	5.0	5.5	V
Assured supply current		I_{DD}	—	Normal speed	$XI = 16.9344\text{ MHz}$	45	50	60	mA
				4 times speed		50	55	65	
Input voltage	"H" Level	$V_{IH} (1)$	—	CMOS Input Terminal (except analog input)		3.5	—	—	V
	"L" Level	$V_{IL} (1)$	—			—	—	1.5	
	"H" Level	$V_{IH} (2)$	—	Schmit input terminal		4.0	—	—	
	"L" Level	$V_{IL} (2)$	—			—	—	1.0	
Input current	"H" Level	I_{IH}	—	$V_{IH} = 5\text{ V}$	CMOS Input Terminal (except analog input)	—	—	1.0	μA
	"L" Level	I_{IL}	—	$V_{IL} = 0\text{ V}$		-1.0	—	—	
Tri-state leak current	"H" Level	I_{TLH}	—	$V_{IH} = 5\text{ V}$	following (1)	—	—	0.1	μA
	"L" Level	I_{TLL}	—	$V_{IL} = 0\text{ V}$		-0.1	—	—	
Output current	"H" Level	$I_{OH} (1)$	—	$V_{OH} = 4.6\text{ V}$	following (1) (except TMAXS, TMAX)	—	—	-1.0	mA
	"L" Level	$I_{OL} (1)$	—	$V_{OL} = 0.4\text{ V}$		2.0	—	—	
	"H" Level	$I_{OH} (2)$	—	$V_{OH} = 4.6\text{ V}$	following (2)	—	—	-1.0	
	"L" Level	$I_{OL} (2)$	—	$V_{OH} = 0.4\text{ V}$		2.0	—	—	
	"H" Level	$I_{OH} (3)$	—	$V_{OH} = 4.6\text{ V}$	following (3)	-1.4	—	-0.6	
	"L" Level	$I_{OL} (3)$	—	$V_{OL} = 0.4\text{ V}$		0.6	—	1.4	
	"H" Level	$I_{OH} (4)$	—	$V_{OH} = 3.8\text{ V}$	following (4)	—	—	-1.0	
	"L" Level	$I_{OL} (4)$	—	$V_{OL} = 0.4\text{ V}$		2.0	—	—	
	"H" Level	$I_{OH} (5)$	—	$V_{OH} = 3.8\text{ V}$	following (6)	—	—	-2.0	
	"L" Level	$I_{OL} (5)$	—	$V_{OL} = 0.4\text{ V}$		4.0	—	—	
V_{REF} output ON resistor		R_{ON}	—	following (4) (except TMAXS, TMAX)		—	—	500	Ω
Pull-up resistor		R_{UP}	—	following (5)		25.0	50.0	75.0	k Ω

	Terminal Name
(1) Terminal	\overline{HSO} , \overline{UHSO} , EMPH, DOUT, MBOV, IPF, SBOK, CLCK, TESIO1 DATA, SFSY, SBSY, SPCK, MONIT, TESIO0, TMAXS, TMAX, SEL FLGA, FLGB, FLGC, FLGD, IO0, IO1, IO2, IO3
(2) Terminal	LRCK, SPDA, COFS, ZDET
(3) Terminal	BUS0~3
(4) Terminal	PDO, TMAXS, TMAX, RFGC, TEBC, FMO, FVO, DMO
(5) Terminal	\overline{DMOUT} , \overline{CKSE} , \overline{DACT} , TSMOD, \overline{RST} , TEST0~4
(6) Terminal	BCK, AOUT

AC Characteristics

1. Microcomputer Interface Timing

Characteristics	Symbol	Test Circuit	Test Condition	Min	Typ.	Max	Unit
\overline{CCE} "H" clock pulse width	t_{CC}	—	—	120	—	—	ns
\overline{CCE} status data access time	t_{CS}	—	\overline{CCE} falling reference	0	—	—	
Status data disable time	t_{SZ1}	—	\overline{CCE} rising reference	0	—	—	
\overline{CCE} , BUCK delay pulse width	t_{CB}	—	\overline{CCE} falling reference	0	—	—	
BUCK "L" clock pulse width	t_{BLW}	—	Write, SRC mode	120	—	—	
	t_{BLW}	—	QDRC mode	240	—	—	
BUCK "H" clock pulse width (1)	t_{BHW}	—	Write, SRC mode	120	—	—	
BUCK "H" clock pulse width (2)	t_{BHW}	—	QDRC mode (×1)	3000	—	—	
BUCK "H" clock pulse width (3)	t_{BHW}	—	QDRC mode (×2)	1500	—	—	
BUCK "H" clock pulse width (4)	t_{BHW}	—	QDRC mode (×4)	800	—	—	
Write data set-up time	t_{WS}	—	BUCK rising reference	60	—	—	
Write data hold time	t_{WH}	—	BUCK rising reference	20	—	—	
PRTY data access time	t_{BA}	—	BUCK falling reference	0	—	—	
Data disable time	t_{SZ2}	—	BUCK falling reference	0	—	—	
Read data access time	t_{RD}	—	BUCK falling reference	0	—	—	
Data disable time	t_{SZ3}	—	BUCK rising reference	0	—	—	

(1) Idle mode

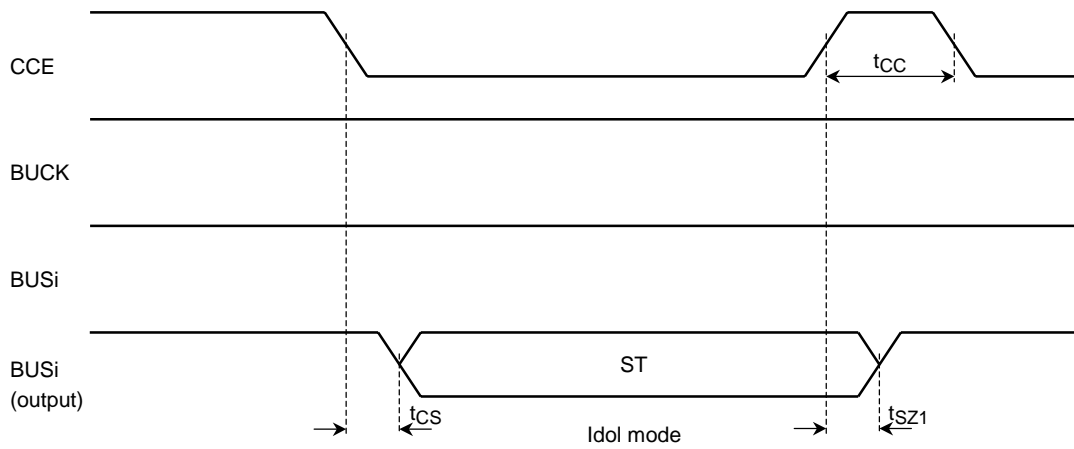

(2) Write command mode

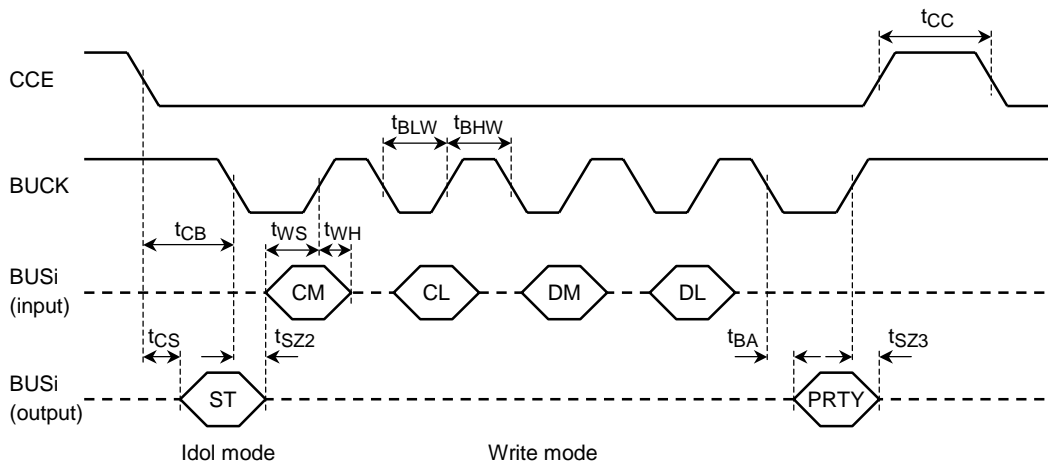

(3) BXXXXX, FXXXXX command at

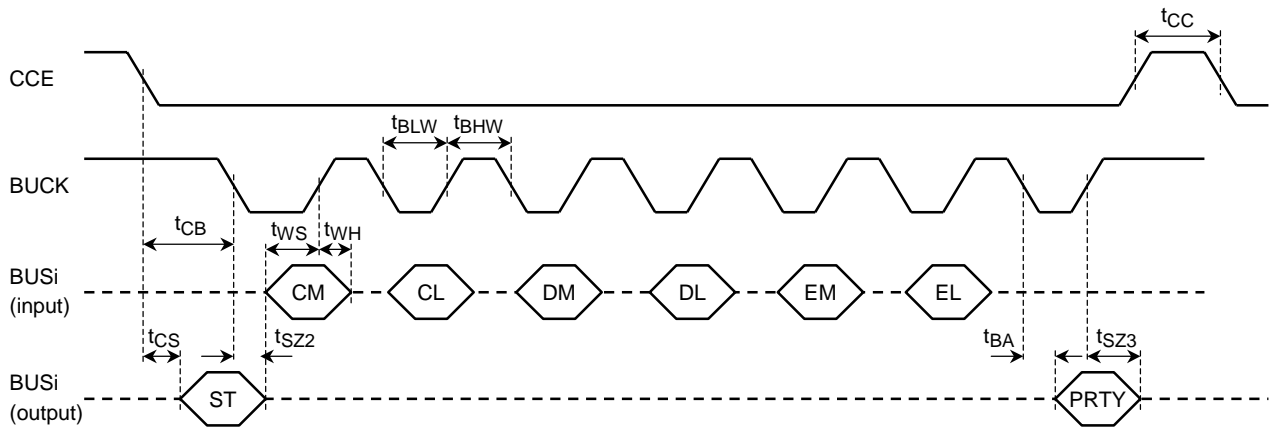

(4) Read command mode

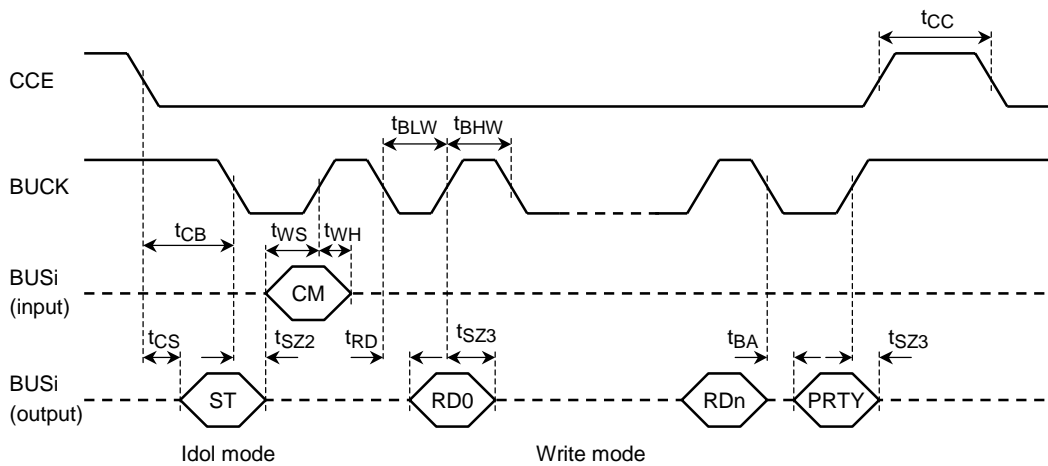

2. AOUT Terminal Output Data Timing

Characteristics		Symbol	Test Circuit	Test Condition	Min	Typ.	Max	Unit
Transfer time (1)	"H" Level	t_{pLH}	—	BCK → AOUT	—	—	5	ns
	"L" Level	t_{pHL}			—	—	5	

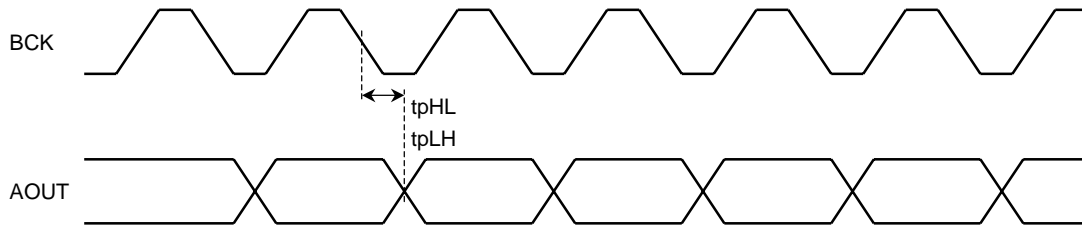

3. SPDA Output Timing

Characteristics		Symbol	Test Circuit	Test Condition	Min	Typ.	Max	Unit
Transfer time	"H" Level	t_{pLH}	—	SPCK → SPDA	—	3	—	ns
	"L" Level	t_{pHL}			—	3	—	

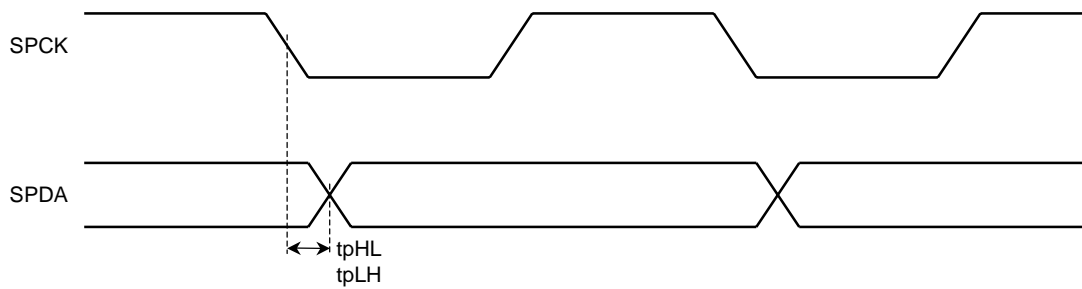

4. DATA, CLCK Input/Output Timing

(1) CLCK input mode

Characteristics		Symbol	Test Circuit	Test Condition	Min	Typ.	Max	Unit
Clock pulse width	"H" Level	t_{HW}	—	CLCK input mode	200	—	—	ns
	"L" Level	t_{LW}			200	—	—	
Input set-up time		t_{Su}			200	—	—	
Transfer time (1)	"L" Level	t_{pHL1}			—	—	5	
Transfer time (2)	"H" Level	t_{pLH2}			—	—	20	
	"L" Level	t_{pHL2}			—	—	20	

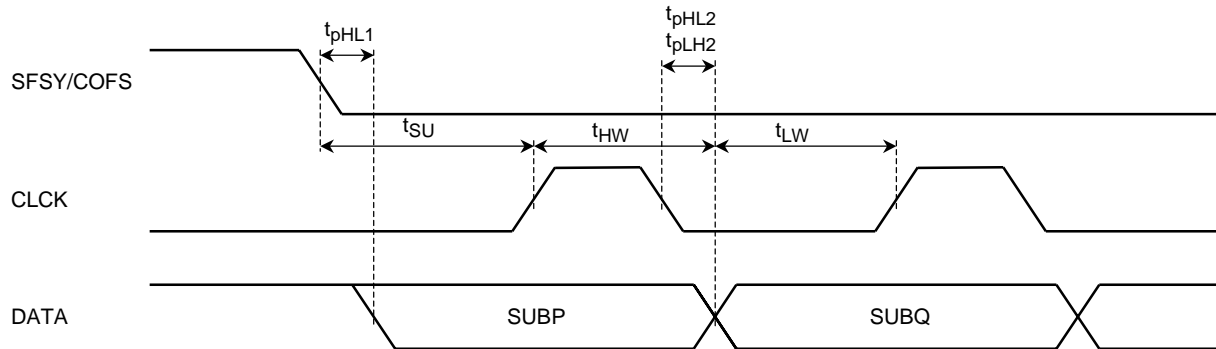

(2) CLCK output mode (t_{HW} , t_{LW} , t_{pLH3} ; 2 times speed = 1/2, 4 times speed = 1/4)

Characteristics		Symbol	Test Circuit	Test Condition	Min	Typ.	Max	Unit
Clock pulse width	"H" Level	t_{HW}	—	CLCK output mode	—	—	1000	ns
	"L" Level	t_{LW}			—	—	1000	
Transfer time (1)	"L" Level	t_{pHL1}			—	—	5	
Transfer time (2)	"H" Level	t_{pLH2}			—	—	20	
	"L" Level	t_{pHL2}			—	—	20	
Transfer time (3)	"H" Level	t_{pLH3}			—	—	900	

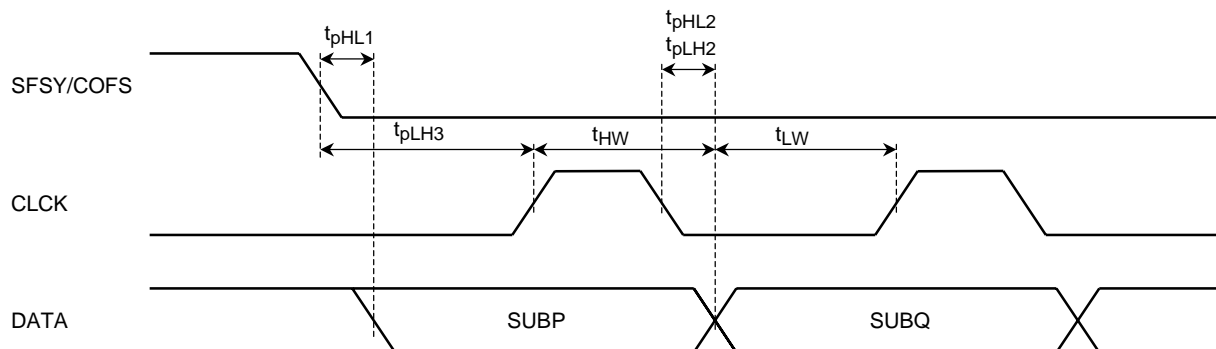

5. SBSY, SBOK Input/Output Control

Characteristics		Symbol	Test Circuit	Test Condition	Min	Typ.	Max	Unit
Transfer time (1)	"H" Level	t_{pLH1}	—	SBSY	—	—	5	ns
	"L" Level	t_{pHL1}					5	
Transfer time (2)	"H" Level	t_{pLH2}	—	SBOK	—	—	15	
	"L" Level	t_{pHL2}					15	

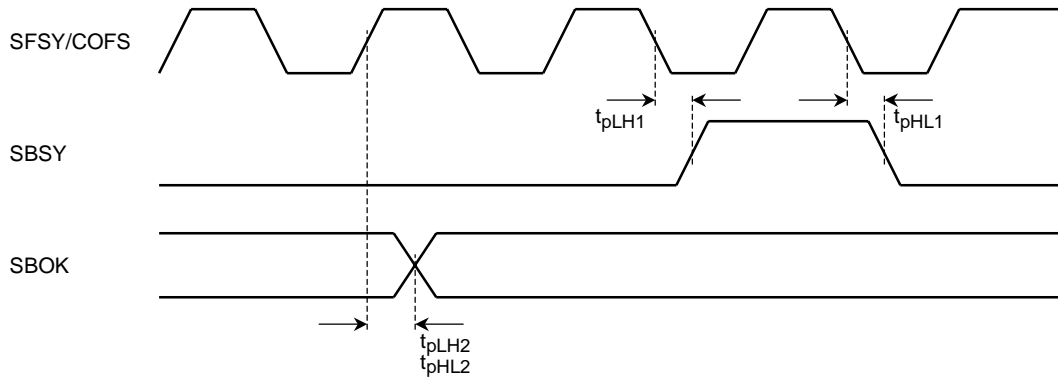

6. Output Terminal Timing

Characteristics		Symbol	Test Circuit	Test Condition	Min	Typ.	Max	Unit	
Output rising time (1)		t_{or1}	—	Terminal (1)	—	—	20	ns	
Output falling time (1)		t_{of1}					15		
Output rising time (2)		t_{or2}	—	Terminal (2)	—	—	20		
Output falling time (2)		t_{of2}					15		
Output rising time (3)		t_{or3}	—	Terminal (3)	—	—	20		
Output falling time (3)		t_{of3}					15		
Output rising time (4)		t_{or4}	—	Terminal (4)	$V_{REF} \rightarrow 2V_{REF}$	—	—	20	
Output falling time (4)				t_{of4}	Terminal (4)	$V_{SS} \rightarrow V_{REF}$	—	—	10
						$2V_{REF} \rightarrow V_{REF}$	—	—	15
						Terminal (4)	$V_{REF} \rightarrow V_{SS}$	—	—

	Terminal Name
(1) Terminal	AOUT, BCK, COFS, LRCK
(2) Terminal	BUS0, BUS1, BUS2, BUS3, CLCK
(3) Terminal	DATA, DOUT, EMPH, FLGA, FLGB, FLGC, FLGD, $\overline{HS0}$, IO0, IO1, IO2, IO3, IPF, MONIT, MBOV, SBOK, SBSY, SEL, SFSY, SPCK, $\overline{UHS0}$
(4) Terminal	PDO, TMAXS, TMAX, RFGC, TEBC, FMO, DMO, FVO

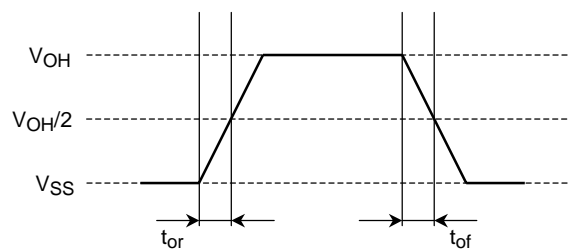

Analog Circuit Characteristics

1. A/D Converter

Characteristics		Test Circuit	Test Condition	Min	Typ.	Max	Unit
Resolution		—	—	—	8	—	bit
Sampling frequency	FE	—	XI = 16.9344 MHz	—	176.4	—	kHz
	TE			—	176.4	—	
	SBAD			—	88.2	—	
	RFRP			—	176.4	—	
Conversion input range		—	Ex. $V_{SS} = 0\text{ V}$, $2V_{REF} = 4.2\text{ V}$	$0.15 \times 2V_{REF}$	—	$0.85 \times 2V_{REF}$	V

2. D/A Converter (focus, tracking equalizer output)

Characteristics		Test Circuit	Test Condition	Min	Typ.	Max	Unit
Bit number		—	—	—	5	—	bit
Sampling frequency		—	—	—	2.8	—	MHz
Output signal range		—	—	AV_{SS}	—	$2V_{REF}$	V

3. PLL Filter Amp.

Characteristics		Test Circuit	Test Condition	Min	Typ.	Max	Unit
Input/output signal range		—	—	V_{SS}	—	$2V_{REF}$	V
Frequency characteristics		—	-3 dB point, RNF = 15 k Ω	2	4	—	MHz

4. VCO (PLL)

Characteristics		Test Circuit	Test Condition	Min	Typ.	Max	Unit
Center oscillation frequency		—	LPFO = V_{REF} , VCOREF = V_{REF}	—	34.6	—	MHz
Frequency variation range		—	VCOREF = V_{REF} , VCOGSL = "H"	± 40	± 50	—	%
		—	VCOREF = V_{REF} , VCOGSL = "L"	—	± 40	—	
VCOREF terminal input voltage range	upper limit	—	V_{REF} reference	—	—	1.0	V
	lower limit			-0.5	—	—	

5. TEZI Signal Comparator

Characteristics		Test Circuit	Test Condition	Min	Typ.	Max	Unit
Input range		—	—	V_{SS}	—	$2V_{REF}$	V
Input amplitude		—	—	1.0	—	3.5	V_{p-p}
Hysteresis voltage		—	V_{REF} reference	—	100	—	mV

6. RFZI Signal Comparator

Characteristics	Test Circuit	Test Condition	Min	Typ.	Max	Unit
Input range	—	—	V_{SS}	—	$2V_{REF}$	V
Input amplitude	—	—	1.0	—	3.5	V_{p-p}
Hysteresis voltage	—	V_{REF} reference (no external register to RFCT terminal)	—	100	—	mV

7. Data Slicer Circuit

Characteristics	Test Circuit	Test Condition	Min	Typ.	Max	Unit
(comparator)						
Input amplitude	—	V_{REF} reference	—	1.2	2.0	V_{p-p}
Response time	—	$RFI = 0.6 V_{p-p}$, $f = 700$ kHz	30	60	90	ns
(R-2R DAC)						
Output conversion range	—	—	1.58	—	2.59	V
Output impedance	—	—	—	2.5	—	$k\Omega$

8. PWM Converter Output (RFGC, TEBC, FMO, FVO, DMO)

Characteristics	Test Circuit	Test Condition	Min	Typ.	Max	Unit
PWM accuracy	—	—	—	8	—	bit
Sampling frequency	—	—	—	88.2	—	kHz
Output signal range	—	—	AV_{SS}	—	$2V_{REF}$	V

DAC Characteristics

Characteristics	Symbol	Test Circuit	Test Condition	Min	Typ.	Max	Unit
Total harmonic distortion + noise	THD + N	1	1 kHz sine wave, full scale input, PXI = "L"	—	-85	-80	dB
S/N ratio	S/N	1	PXI = "L"	90	100	—	dB
Dynamic range	DR	1	1 kHz sine wave, -60dB input conversion	85	90	—	dB
Cross talk	CT	1	1 kHz sine wave, full scale input, PXI = "L"	—	-90	-85	dB
Analog output amplitude	DAC out	1	1 kHz sine wave, full scale input, PXI = "L"	1.12	1.20	1.28	V _{rms}

Test Circuit 1: Application Circuit is Used.

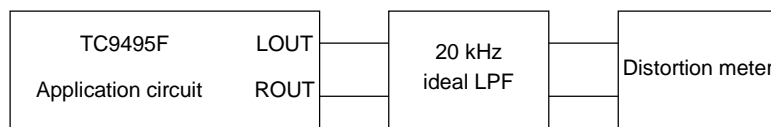

LPF: SHIBASOKU 725C
Distortion meter: SHIBASOKU 725C

Characteristics	Distortion Filter Setting: A-wait
THD + N, CT	OFF
S/N, DR	ON

A-WAIT: IEC-A (corresponding)

Application Circuit

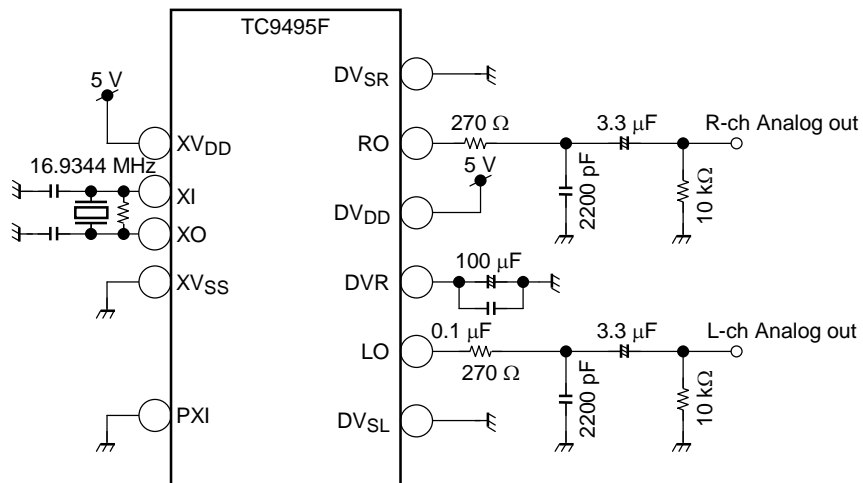

Package Dimensions

QFP100-P-1420-0.65A

Unit : mm

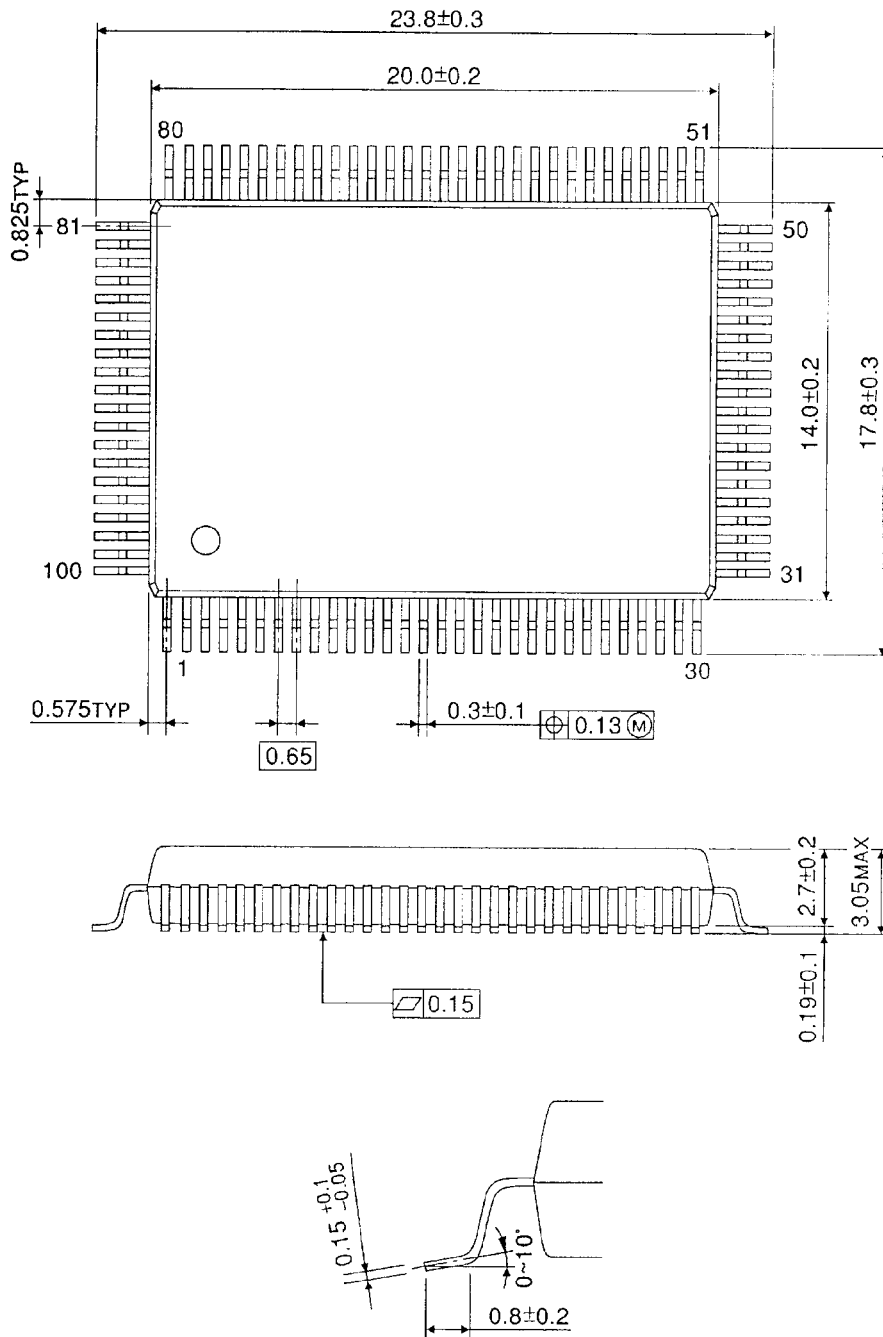

Weight: 1.6 g (typ.)

RESTRICTIONS ON PRODUCT USE

000707EBA

- TOSHIBA is continually working to improve the quality and reliability of its products. Nevertheless, semiconductor devices in general can malfunction or fail due to their inherent electrical sensitivity and vulnerability to physical stress. It is the responsibility of the buyer, when utilizing TOSHIBA products, to comply with the standards of safety in making a safe design for the entire system, and to avoid situations in which a malfunction or failure of such TOSHIBA products could cause loss of human life, bodily injury or damage to property.
In developing your designs, please ensure that TOSHIBA products are used within specified operating ranges as set forth in the most recent TOSHIBA products specifications. Also, please keep in mind the precautions and conditions set forth in the "Handling Guide for Semiconductor Devices," or "TOSHIBA Semiconductor Reliability Handbook" etc..
- The TOSHIBA products listed in this document are intended for usage in general electronics applications (computer, personal equipment, office equipment, measuring equipment, industrial robotics, domestic appliances, etc.). These TOSHIBA products are neither intended nor warranted for usage in equipment that requires extraordinarily high quality and/or reliability or a malfunction or failure of which may cause loss of human life or bodily injury ("Unintended Usage"). Unintended Usage include atomic energy control instruments, airplane or spaceship instruments, transportation instruments, traffic signal instruments, combustion control instruments, medical instruments, all types of safety devices, etc.. Unintended Usage of TOSHIBA products listed in this document shall be made at the customer's own risk.
- The products described in this document are subject to the foreign exchange and foreign trade laws.
- The information contained herein is presented only as a guide for the applications of our products. No responsibility is assumed by TOSHIBA CORPORATION for any infringements of intellectual property or other rights of the third parties which may result from its use. No license is granted by implication or otherwise under any intellectual property or other rights of TOSHIBA CORPORATION or others.
- The information contained herein is subject to change without notice.