



## TCA4311 Hot Swappable 2-Wire Bus Buffers

*Not Recommended for New Designs*

### 1 Features

- Operating Power-Supply Voltage Range of 2.7-V to 5.5-V
- Supports Bidirectional Data Transfer of I<sup>2</sup>C Bus Signals
- SDA and SCL Lines Are Buffered Which Increases Fanout
- 1-V Precharge on All SDA and SCL Lines Prevents Corruption During Live Board Insertion and Removal From Backplane
- SDA and SCL Input Lines Are Isolated From Outputs
- Accommodates Standard Mode and Fast Mode I<sup>2</sup>C Devices
- Applications Include Hot Board Insertion and Bus Extension
- Low I<sub>CC</sub> Chip Disable of <1 μA
- READY Open-Drain Output
- Supports Clock Stretching, Arbitration, and Synchronization
- Powered-Off High-Impedance I<sup>2</sup>C Pins
- Open-Drain I<sup>2</sup>C Pins
- Latch-Up Performance Exceeds 100 mA Per JESD 78, Class II
- ESD Protection Exceeds JESD 22
  - 8000-V Human-Body Model (A114-A)
  - 200-V Machine Model (A115-A)
  - 1000-V Charged-Device Model (C101)

### 2 Description

The TCA4311 is a hot swappable I<sup>2</sup>C bus buffer that supports I/O card insertion into a live backplane without corruption of the data and clock busses. Control circuitry prevents the backplane from being connected to the card until a stop command or bus idle occurs on the backplane without bus contention on the card. When the connection is made, this device provides bidirectional buffering, keeping the backplane and card capacitances isolated. During insertion, the SDA and SCL lines are precharged to 1 V to minimize the current required to charge the parasitic capacitance of the chip.

When the I<sup>2</sup>C bus is idle, the TCA4311 can be put into shutdown mode by setting the EN pin low. When EN is high, the TCA4311 resumes normal operation. It also includes an open drain READY output pin, which indicates that the backplane and card sides are connected together. When READY is high, the SDAIN and SCLIN are connected to SDAOUT and SCLOUT. When the two sides are disconnected, READY is low.

Both the backplane and card may be powered with supply voltages ranging from 2.7 V to 5.5 V, with no restrictions on which supply voltage is higher.

The TCA4311 has standard open-drain I/Os. The size of the pullup resistors to the I/Os depends on the system, but each side of this buffer must have a pullup resistor. The device is designed to work with Standard Mode and Fast Mode I<sup>2</sup>C devices in addition to SMBus devices. Standard Mode I<sup>2</sup>C devices only specify 3 mA in a generic I<sup>2</sup>C system where Standard Mode devices and multiple masters are possible. Under certain conditions, high termination currents can be used.

#### Device Information<sup>(1)</sup>

| PART NUMBER | PACKAGE   | BODY SIZE (NOM)   |
|-------------|-----------|-------------------|
| TCA4311     | SOIC (8)  | 4.90 mm x 3.91 mm |
|             | VSSOP (8) | 3.00 mm x 3.00 mm |

(1) For all available packages, see the orderable addendum at the end of the datasheet.

#### D OR DGK PACKAGES (TOP VIEW)

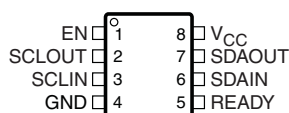

## Table of Contents

|  |          |  |           |
|--|----------|--|-----------|
| <b>1 Features</b> .....                          | <b>1</b> | <b>7 Detailed Description</b> .....                              | <b>9</b>  |
| <b>2 Description</b> .....                       | <b>1</b> | 7.1 Functional Block Diagram .....                               | 9         |
| <b>3 Revision History</b> .....                  | <b>2</b> | 7.2 Feature Description.....                                     | 10        |
| <b>4 Pin Configuration and Functions</b> .....   | <b>3</b> | 7.3 Device Functional Modes.....                                 | 11        |
| <b>5 Specifications</b> .....                    | <b>3</b> | <b>8 Application and Implementation</b> .....                    | <b>12</b> |
| 5.1 Absolute Maximum Ratings .....               | 3        | 8.1 Typical Application .....                                    | 12        |
| 5.2 Handling Ratings.....                        | 4        | <b>9 Device and Documentation Support</b> .....                  | <b>16</b> |
| 5.3 Recommended Operating Conditions .....       | 4        | 9.1 Trademarks .....   | 16        |
| 5.4 Electrical Characteristics.....              | 5        | 9.2 Electrostatic Discharge Caution.....                         | 16        |
| 5.5 Typical Characteristics.....                 | 6        | 9.3 Glossary .....   | 16        |
| <b>6 Parameter Measurement Information</b> ..... | <b>7</b> | <b>10 Mechanical, Packaging, and Orderable Information</b> ..... | <b>16</b> |

### 3 Revision History

| Changes from Original (December 2008) to Revision A | Page |
|---|------|
| • Added Missing ACK Errata section. ....            | 10   |

## 4 Pin Configuration and Functions

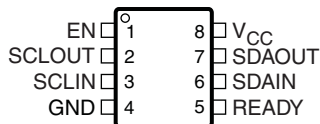
**D OR DGK PACKAGES  
(TOP VIEW)**

**Pin Functions**

| SOIC (D) OR MSOP (DGK) PACKAGE |                 | DESCRIPTION  |
|--------------------------------|-----------------|--|
| PIN NUMBER                     | NAME            |  |
| 1                              | EN              | Active-high chip enable pin. If EN is low, the TCA4311 is in a low current (<1 $\mu$ A) mode. It also disables the rise-time accelerators, disables the bus precharge circuitry, drives READY low, isolates SDAIN from SDAOUT and isolates SCLIN from SCLOUT. EN should be high (at V <sub>CC</sub> ) for normal operation. Connect EN to V <sub>CC</sub> if this feature is not being used. |
| 2                              | SCLOUT          | Serial clock output. Connect this pin to the SCL bus on the card.  |
| 3                              | SCLIN           | Serial clock input. Connect this pin to the SCL bus on the backplane.  |
| 4                              | GND             | Supply ground  |
| 5                              | READY           | Connection flag/rise-time accelerator control. READY is low when either EN is low or the start-up sequence described in the operation section has not been completed. READY goes high when EN is high and start-up is complete. Connect a 10-k $\Omega$ resistor from this pin to V <sub>CC</sub> to provide the pull up.  |
| 6                              | SDAIN           | Serial data input. Connect this pin to the SDA bus on the backplane.   |
| 7                              | SDAOUT          | Serial data output. Connect this pin to the SDA bus on the card.   |
| 8                              | V <sub>CC</sub> | Supply power. Main input power supply from backplane. This is the supply voltage for the devices on the backplane I <sup>2</sup> C busses. Connect pullup resistors from SDAIN and SCLIN (and also from SDAOUT and SCLOUT) to this pin. Place a bypass capacitor of at least 0.01 $\mu$ F close to this pin for best results.  |

## 5 Specifications

### 5.1 Absolute Maximum Ratings<sup>(1)</sup>

over operating free-air temperature range (unless otherwise noted)

|                  |   | MIN         | MAX       | UNIT |
|------------------|---|-------------|-----------|------|
| V <sub>CC</sub>  | Supply voltage range                              | -0.5        | 7         | V    |
| V <sub>I/O</sub> | I <sup>2</sup> C bus voltage range <sup>(2)</sup> | -0.3        | 7         | V    |
| V <sub>I</sub>   | Input voltage range <sup>(2)</sup>                | -0.3        | 7         | V    |
| I <sub>IK</sub>  | Input clamp current                               |             | -50       | mA   |
| I <sub>OK</sub>  | Output clamp current                              |             | -50       | mA   |
| I <sub>O</sub>   | Continuous output current                         |             | $\pm$ 50  | mA   |
| I <sub>CC</sub>  | Continuous current through V <sub>CC</sub> or GND |             | $\pm$ 100 | mA   |
| $\theta_{JA}$    | Package thermal impedance <sup>(3)</sup>          | D package   | 97        | °C/W |
|                  |   | DGK package | 172       |      |

- (1) Stresses beyond those listed under "absolute maximum ratings" may cause permanent damage to the device. These are stress ratings only, and functional operation of the device at these or any other conditions beyond those indicated under "recommended operating conditions" is not implied. Exposure to absolute-maximum-rated conditions for extended periods may affect device reliability.
- (2) The input negative-voltage and output voltage ratings may be exceeded if the input and output current ratings are observed.
- (3) The package thermal impedance is calculated in accordance with JESD 51-7.

TCA4311

SCPS173A –DECEMBER 2008–REVISED JUNE 2014

www.ti.com

### 5.2 Handling Ratings

|                    |                           |  | MIN | MAX  | UNIT |
|--------------------|---------------------------|--|-----|------|------|
| T <sub>stg</sub>   | Storage temperature range |  | -65 | 150  | °C   |
| V <sub>(ESD)</sub> | Electrostatic discharge   | Human body model (HBM), per ANSI/ESDA/JEDEC JS-001, all pins <sup>(1)</sup>              | 0   | 8000 | V    |
|                    |                           | Charged device model (CDM), per JEDEC specification JESD22-C101, all pins <sup>(2)</sup> | 0   | 1000 |      |

(1) JEDEC document JEP155 states that 500-V HBM allows safe manufacturing with a standard ESD control process.

(2) JEDEC document JEP157 states that 250-V CDM allows safe manufacturing with a standard ESD control process.

### 5.3 Recommended Operating Conditions

|                 |                                |                         | MIN                   | MAX                   | UNIT |
|-----------------|--------------------------------|-------------------------|-----------------------|-----------------------|------|
| V <sub>CC</sub> | Supply voltage                 |                         | 2.7                   | 5.5                   | V    |
| V <sub>IH</sub> | High-level input voltage       | SDA and SCL inputs      | 0.7 × V <sub>CC</sub> | 5.5                   | V    |
|                 |                                | EN input                | 2                     | 5.5                   |      |
| V <sub>IL</sub> | Low-level input voltage        | SDA and SCL inputs      | -0.5                  | 0.3 × V <sub>CC</sub> | V    |
|                 |                                | EN input                | -0.5                  | 0.8                   |      |
| I <sub>OL</sub> | Low-level output current       | V <sub>CC</sub> = 3 V   |                       | 3                     | mA   |
|                 |                                | V <sub>CC</sub> = 4.5 V |                       | 3                     |      |
| T <sub>A</sub>  | Operating free-air temperature |                         | -40                   | 85                    | °C   |

## 5.4 Electrical Characteristics

over operating free-air temperature range (unless otherwise noted)

| PARAMETER                      |                                   | TEST CONDITIONS   | MIN                 | TYP                 | MAX                 | UNIT          |
|--------------------------------|-----------------------------------|---|---------------------|---------------------|---------------------|---------------|
| <b>Power Supply</b>            |                                   |   |                     |                     |                     |               |
| $V_{CC}$                       | Positive supply voltage           |   | 2.7                 |                     | 5.5                 | V             |
| $I_{CC}$                       | Supply current                    | $V_{CC} = 5.5\text{ V}$ , $V_{SDAIN} = V_{SCLIN} = 0\text{ V}$                  |                     | 5.1                 | 7                   | mA            |
| $I_{SD}$                       | Supply current in shutdown mode   | $V_{EN} = 0\text{ V}$   |                     | 0.1                 |                     | $\mu\text{A}$ |
| <b>Start-Up Circuitry</b>      |                                   |   |                     |                     |                     |               |
| $V_{PRE}$                      | Precharge voltage                 | SDA, SCL floating   | 0.8                 | 1                   | 1.2                 | V             |
| $t_{IDLE}$                     | Bus idle time                     |   | 50                  | 95                  | 150                 | $\mu\text{s}$ |
| $V_{EN}$                       | EN threshold voltage              |   |                     | $0.5 \times V_{CC}$ | $0.9 \times V_{CC}$ | V             |
| $V_{DIS}$                      | Disable threshold voltage         | EN Pin  | $0.1 \times V_{CC}$ | $0.5 \times V_{CC}$ |                     | V             |
| $I_{EN}$                       | EN input current                  | EN from 0 V to $V_{CC}$   |                     | $\pm 0.1$           | $\pm 1$             | $\mu\text{A}$ |
| $t_{EN}$                       | Enable time                       |   |                     | 95                  |                     | $\mu\text{s}$ |
| $t_{DIS}$                      | Disable time (EN to READY)        |   |                     | 30                  |                     | ns            |
| $t_{STOP}$                     | SDAIN to READY delay after STOP   |   |                     | 1.2                 |                     | $\mu\text{s}$ |
| $t_{READY}$                    | SCLOUT/SDAOUT to READY            |   |                     | 0.8                 |                     | $\mu\text{s}$ |
| $I_{OFF}$                      | READY OFF state leakage current   |   |                     | $\pm 0.1$           |                     | $\mu\text{A}$ |
| $V_{OL}$                       | READY output low voltage          | $I_{PULLUP} = 3\text{ mA}$  |                     |                     | 0.4                 | V             |
| <b>Rise-Time Accelerators</b>  |                                   |   |                     |                     |                     |               |
| $I_{PULLUPAC}$                 | Transient boosted pull-up current | Positive transition on SDA, SCL, $V_{CC} = 2.7\text{ V}$ ,                      | 1                   | 2                   |                     | mA            |
| <b>Input-Output Connection</b> |                                   |   |                     |                     |                     |               |
| $V_{OS}$                       | Input-output offset voltage       | 10 k $\Omega$ to $V_{CC}$ on SDA, SCL, $V_{CC} = 3.3\text{ V}$ , <sup>(1)</sup> | 0                   | 100                 | 175                 | mV            |
| $C_{IN}$                       | Digital input capacitance         |   |                     |                     | 10                  | pF            |
| $V_{OL}$                       | Output low voltage, input = 0 V   | SDA, SCL pins, $I_{SINK} = 3\text{ mA}$ ,                                       | 0                   |                     | 0.4                 | V             |
| $I_I$                          | Input leakage current             | SDA, SCL pins = $V_{CC} = 5.5\text{ V}$   |                     |                     | $\pm 5$             | $\mu\text{A}$ |

(1) The connection circuitry always regulates its output to a higher voltage than its input. The magnitude of this offset voltage as a function of the pullup resistor and  $V_{CC}$  voltage is shown in the [Typical Characteristics](#) section.

### 5.5 Typical Characteristics

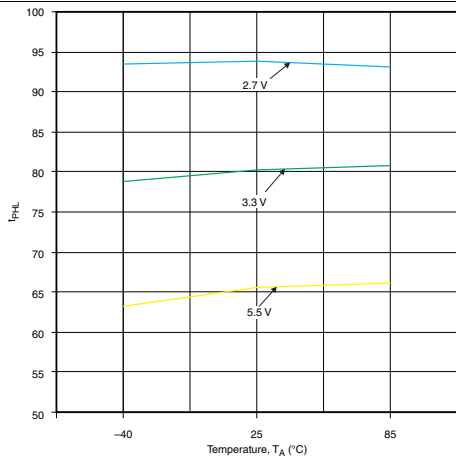

Figure 1. Input/Output  $t_{PLH}$  vs Temperature

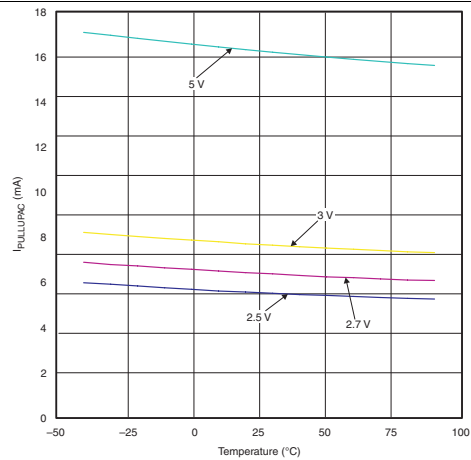

Figure 2.  $I_{PULLUPAC}$  vs Temperature

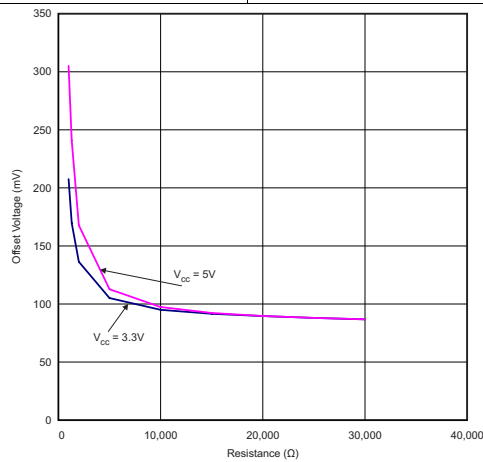
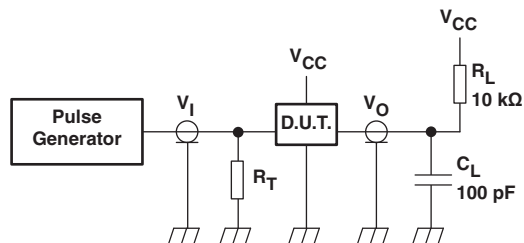

Figure 3. Input-Output Offset Voltage vs Pull-up Resistor

## 6 Parameter Measurement Information



$R_L$  = Load resistor

$C_L$  = Load capacitance includes jig and probe capacitance

$R_T$  = Termination resistance should be equal to the output impedance  $Z_0$  of the pulse generators.

Figure 4. Test Circuitry for Switching Times

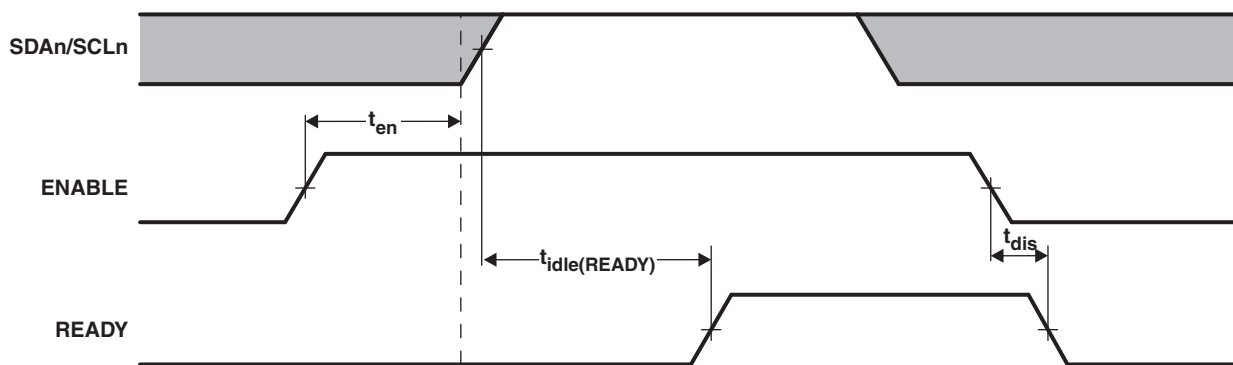

Figure 5. Timing for  $t_{en}$ ,  $t_{idle(READY)}$ , and  $t_{dis}$

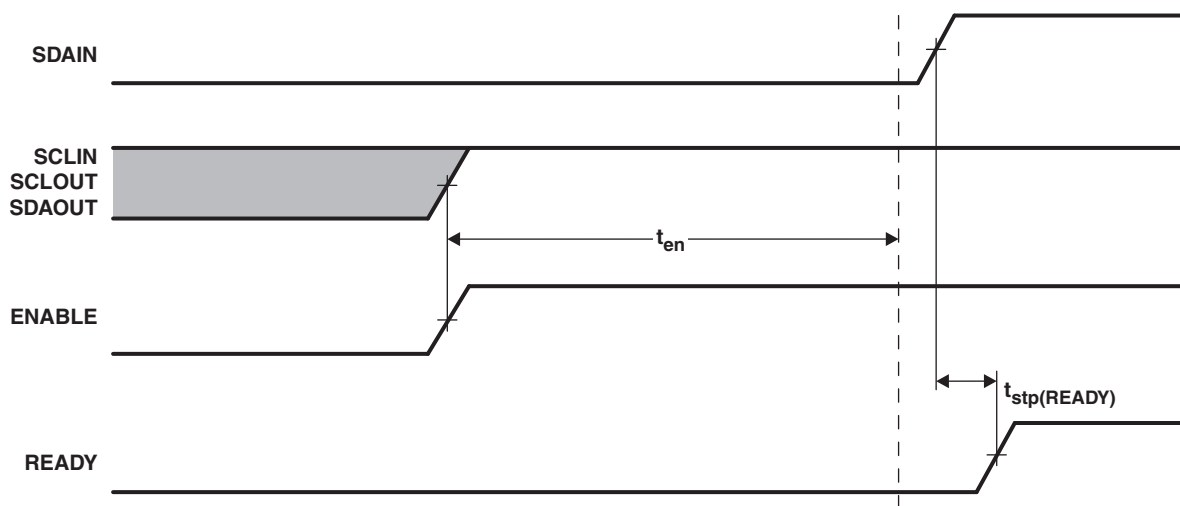

Figure 6.  $t_{stp(READY)}$  That Can Occur After  $t_{en}$

Parameter Measurement Information (continued)

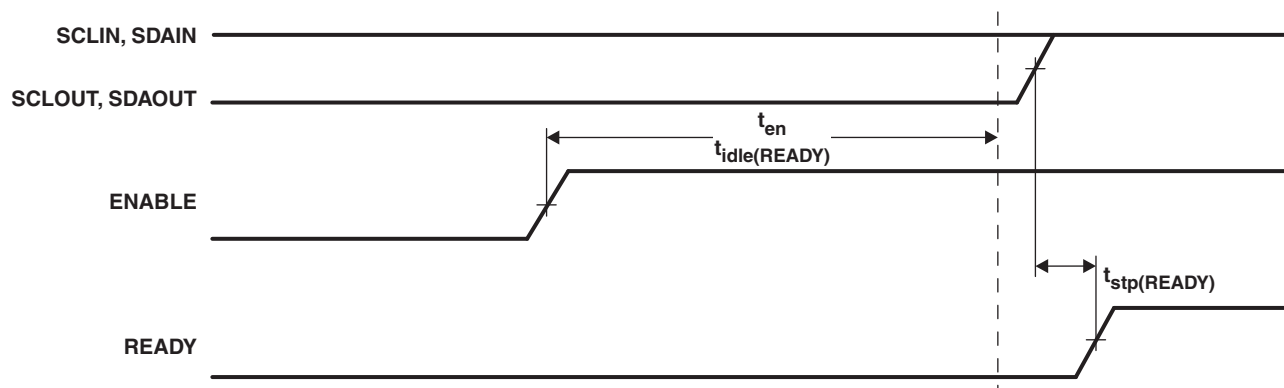
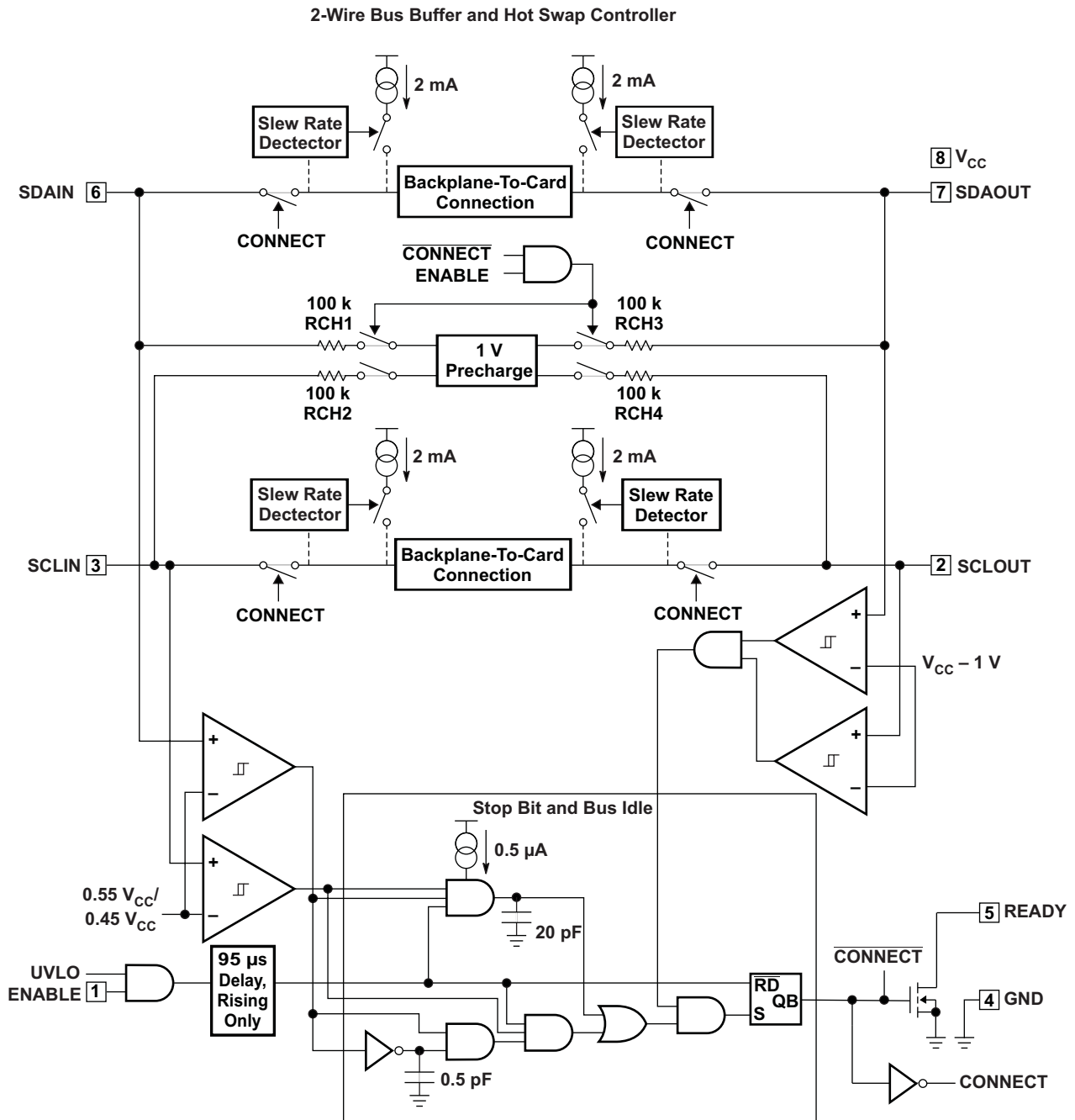

Figure 7.  $t_{stp(READY)}$  That Can Occur After  $t_{en}$  and  $t_{idle(READY)}$



## 7 Detailed Description

### 7.1 Functional Block Diagram



## 7.2 Feature Description

### 7.2.1 Rise-Time Accelerators

Once connection has been established, rise-time accelerator circuits on all four SDA and SCL pins are activated. These allow the user to choose weaker DC pullup currents on the bus, reducing power consumption while still meeting system rise-time requirements. During positive bus transitions, the TCA4311 switches in 2 mA (typical) of current to quickly slew the SDA and SCL lines once their DC voltages exceed 0.6 V. Using a general rule of 20 pF of capacitance for every device on the bus (10 pF for the device and 10 pF for interconnect), choose a pullup current so that the bus will rise on its own at a rate of at least 1.25 V/ $\mu$ s to guarantee activation of the accelerators.

For example, assume an SMBus system with  $V_{CC} = 3$  V, a 10-k $\Omega$  pullup resistor and equivalent bus capacitance of 200 pF. The rise-time of an SMBus system is calculated from  $(V_{IL(MAX)} - 0.15$  V) to  $(V_{IH(MIN)} + 0.15$  V), or 0.65 V to 2.25 V. It takes an RC circuit 0.92 time constants to traverse this voltage for a 3 V supply; in this case,  $0.92 \times (10$  k $\Omega \times 200$  pF) = 1.84  $\mu$ s. Thus, the system exceeds the maximum allowed rise-time of 1  $\mu$ s by 84%. However, using the rise-time accelerators, which are activated at a DC threshold of below 0.65 V, the worst-case rise-time is:  $(2.25$  V – 0.65 V)  $\times$  200 pF/1 mA = 320 ns, which meets the 1  $\mu$ s rise-time requirement.

### 7.2.2 READY Digital Output

This pin provides a digital flag which is low when either EN is low or the start-up sequence described earlier in this section has not been completed. READY goes high when EN is high and start-up is complete. The pin is driven by an open drain pull-down capable of sinking 3 mA while holding 0.4 V on the pin. Connect a resistor of 10 k $\Omega$  to  $V_{CC}$  to provide the pullup.

### 7.2.3 EN Low Current Disable

Grounding the EN pin disconnects the backplane side from the card side, disables the rise-time accelerators, drives READY low, disables the bus precharge circuitry and puts the part in a near-zero current state. When the pin voltage is driven all the way to  $V_{CC}$ , the part waits for data transactions on both the backplane and card sides to be complete (as described in the Start-Up section) before reconnecting the two sides.

### 7.2.4 Missing ACK Errata

#### Description

- When the slave (or master) device sends an ACK bit, a logic low on SDA during the 9<sup>th</sup> clock cycle, the slave (or master) may pull the SDA line low while the rise time accelerators are engaged, and the master (or slave) side will stay high.
- The rise time accelerators will be engaged when the voltage is above 0.6 V (typical), and below  $V_{IH}$ ,  $0.7 \times V_{CC}$
- In the example described below, SDAOUT is a slave attempting to send an ACK bit. SDAOUT pulls to a logic low but the ACK is not transferred to the other side and SDAIN will remain high unexpectedly.

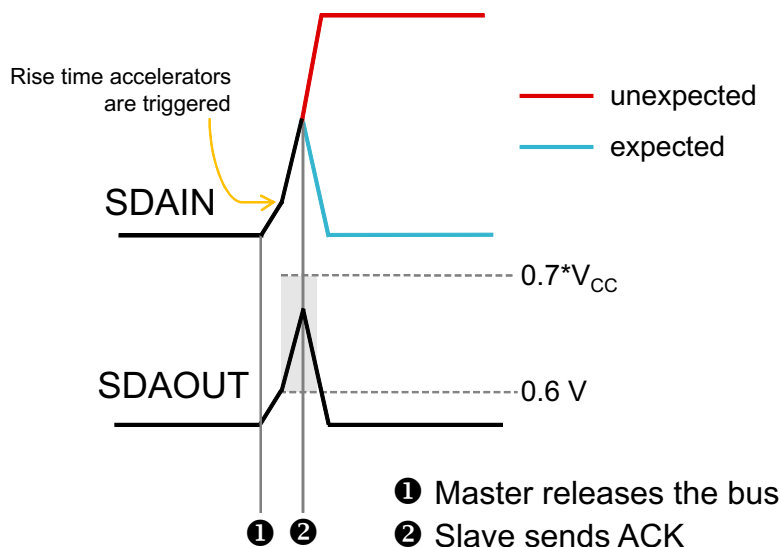

## Feature Description (continued)

### System Impact

The ACK bit will not be transferred through the TCA4311, and the slave or master device will interpret the result as a NACK.

### System Workaround

Usage of the TCA4311A is recommended.

## 7.3 Device Functional Modes

### 7.3.1 Start-Up

When the TCA4311 first receives power on its  $V_{CC}$  pin, either during power-up or during live insertion, it starts in an undervoltage lockout (UVLO) state, ignoring any activity on the SDA and SCL pins until  $V_{CC}$  rises above 2.5 V.

During this time, the 1 V precharge circuitry is also active and forces 1 V through 100-k $\Omega$  nominal resistors to the SDA and SCL pins. Because the I/O card is being plugged into a live backplane, the voltage on the backplane SDA and SCL busses may be anywhere between 0 V and  $V_{CC}$ . Precharging the SCL and SDA pins to 1 V minimizes the worst-case voltage differential these pins will see at the moment of connection, therefore minimizing the amount of disturbance caused by the I/O card.

Once the TCA4311 comes out of UVLO, it assumes that SDAIN and SCLIN have been inserted into a live system and that SDAOUT and SCLOUT are being powered up at the same time as itself. Therefore, it looks for either a stop bit or bus idle condition on the backplane side to indicate the completion of a data transaction. When either one occurs, the part also verifies that both the SDAOUT and SCLOUT voltages are high. When all of these conditions are met, the input-to-output connection circuitry is activated, joining the SDA and SCL busses on the I/O card with those on the backplane, and the rise time accelerators are enabled.

### 7.3.2 Connection Circuitry

Once the connection circuitry is activated, the functionality of the SDAIN and SDAOUT pins is identical. A low forced on either pin at any time results in both pin voltages being low. For proper operation, logic low input voltages should be no higher than 0.4 V with respect to the ground pin voltage of the TCA4311. SDAIN and SDAOUT enter a logic high state only when all devices on both SDAIN and SDAOUT release high. The same is true for SCLIN and SCLOUT. This important feature ensures that clock stretching, clock synchronization, arbitration and the acknowledge protocol always work, regardless of how the devices in the system are tied to the TCA4311.

Another key feature of the connection circuitry is that it provides bidirectional buffering, keeping the backplane and card capacitances isolated. Because of this isolation, the waveforms on the backplane busses look slightly different than the corresponding card bus waveforms, as described here.

## TCA4311

SCPS173A –DECEMBER 2008–REVISED JUNE 2014

www.ti.com

## 8 Application and Implementation

### 8.1 Typical Application

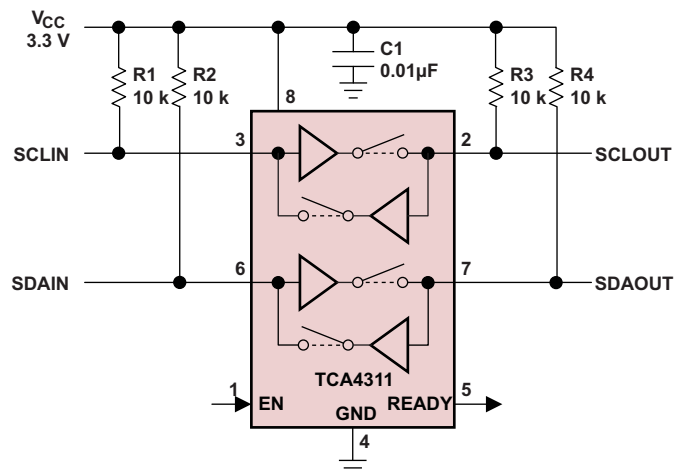

Figure 8. TCA4311 Typical Application

#### 8.1.1 Live Insertion and Capacitance Buffering Application

Figure 9 through Figure 10 illustrate the usage of the TCA4311 in applications that take advantage of both its hot swap controlling and capacitance buffering features. In all of these applications, note that if the I/O cards were plugged directly into the backplane, all of the backplane and card capacitances would add directly together, making rise- and fall-time requirements difficult to meet. Placing a TCA4311 on the edge of each card, however, isolates the card capacitance from the backplane. For a given I/O card, the TCA4311 drives the capacitance of everything on the card and the backplane must drive only the capacitance of the TCA4311, which is less than 10 pF.

Figure 9 shows the TCA4311 in a CompactPCI™ configuration. Connect  $V_{CC}$  and EN to the output of one of the CompactPCI power supply Hot Swap circuits. Use a pullup resistor to EN for a card side enable/disable.

$V_{CC}$  is monitored by a filtered UVLO circuit. With the  $V_{CC}$  voltage powering up after all other pins have established connection, the UVLO circuit ensures that the backplane and card data and clock busses are not connected until the transients associated with live insertion have settled. Owing to their small capacitance, the SDAIN and SCLIN pins cause minimal disturbance on the backplane busses when they make contact with the connector.

Figure 10 shows the TCA4311 in a PCI application, where all of the pins have the same length. In this case, connect an RC series circuit on the I/O card between  $V_{CC}$  and EN. An RC product of 10 ms provides a filter to prevent the TCA4311 from becoming activated until the transients associated with live insertion have settled.

Typical Application (continued)

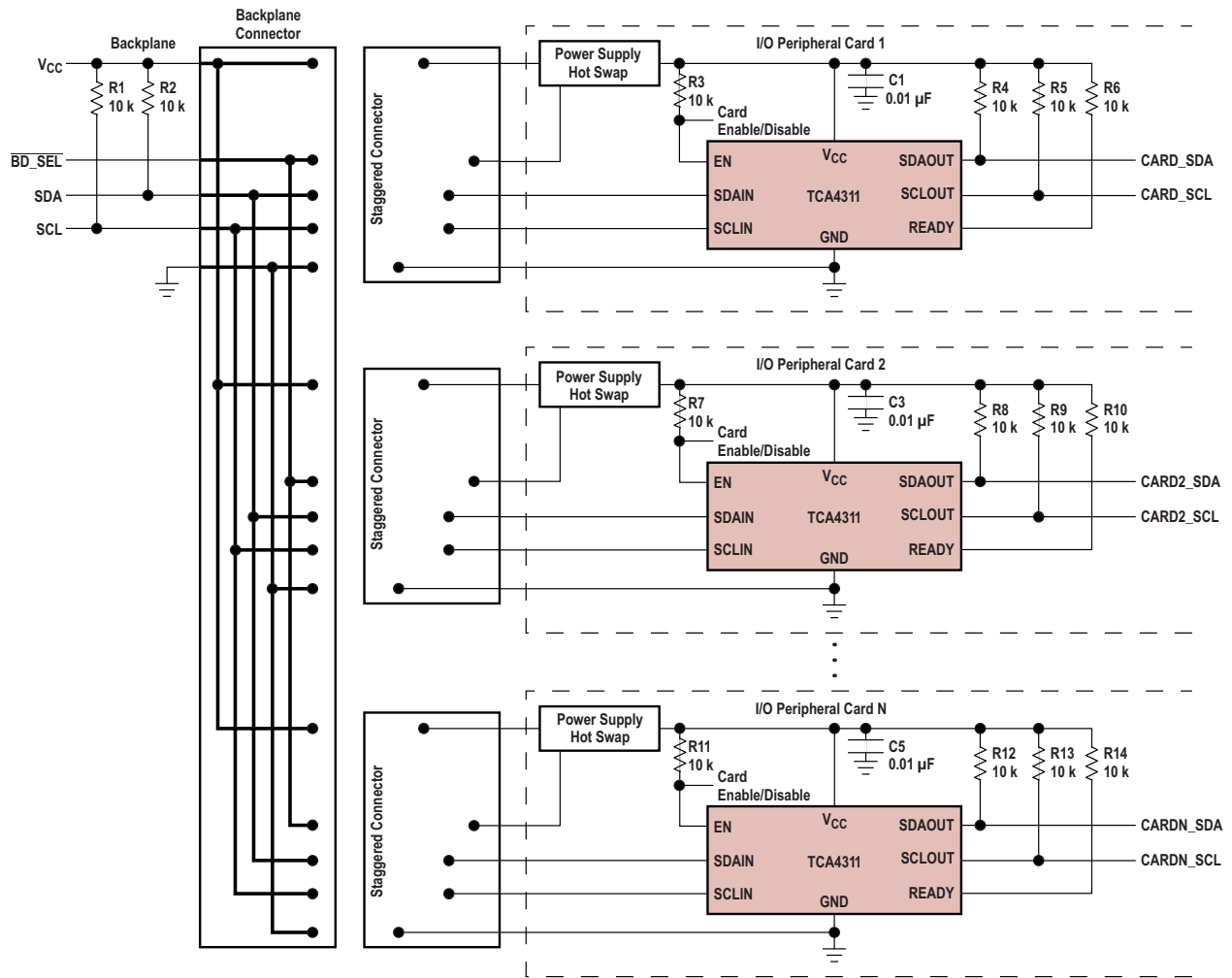

Figure 9. Inserting Multiple I/O Cards into a Live Backplane Using the TCA4311 in a CompactPCI System

TCA4311

SCPS173A –DECEMBER 2008–REVISED JUNE 2014

www.ti.com

Typical Application (continued)

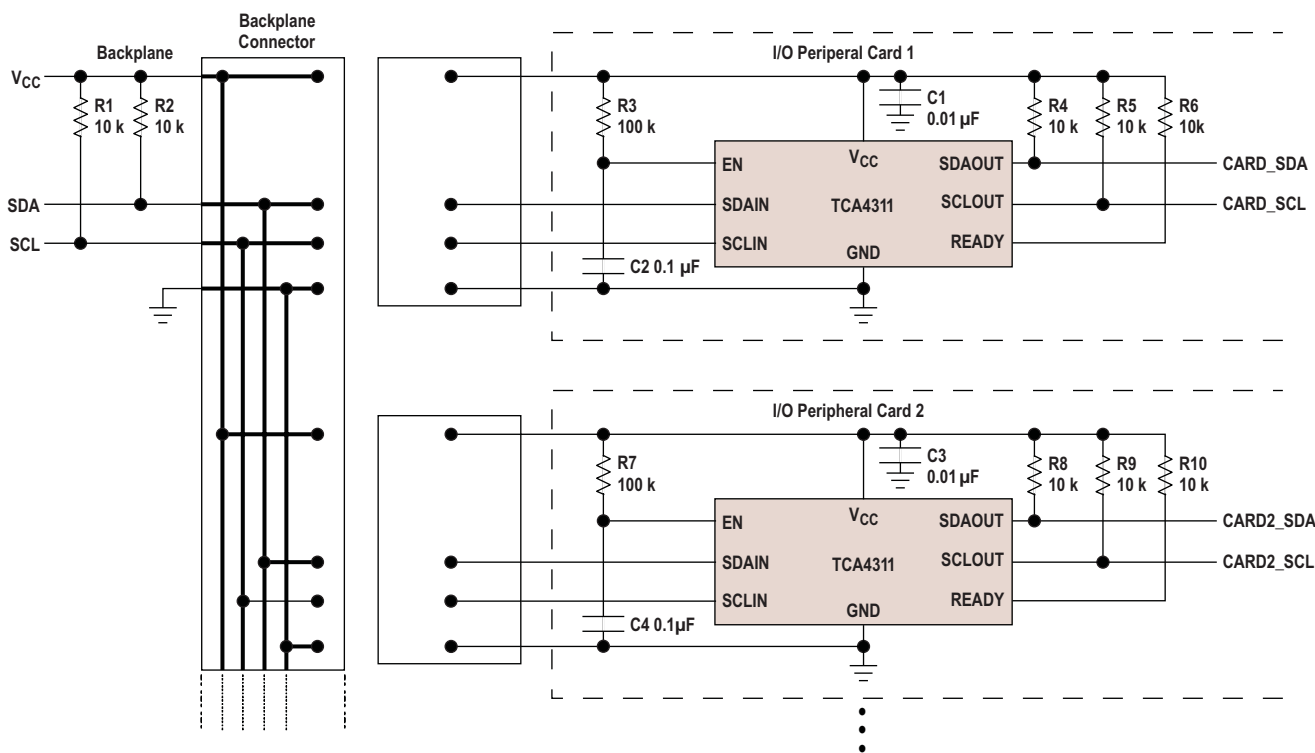

Figure 10. Inserting Multiple I/O Cards into a Live Backplane Using the TCA4311 in a PCI System

8.1.2 Repeater/Bus Extender Application

Users who wish to connect two 2-wire systems separated by a distance can do so by connecting two TCA4311 back-to-back, as shown in Figure 11. The I<sup>2</sup>C specification allows for 400 pF maximum bus capacitance, severely limiting the length of the bus. The SMBus specification places no restriction on bus capacitance, but the limited impedances of devices connected to the bus require systems to remain small if rise- and fall-time specifications are to be met. The strong pullup and pulldown impedances of the TCA4311 are capable of meeting rise- and fall-time specifications for one nanofarad of capacitance, thus allowing much more interconnect distance. In this situation, the differential ground voltage between the two systems may limit the allowed distance, because a valid logic low voltage with respect to the ground at one end of the system may violate the allowed V<sub>OL</sub> specification with respect to the ground at the other end. In addition, the connection circuitry offset voltages of the back-to-back TCA4311 add together, directly contributing to the same problem.

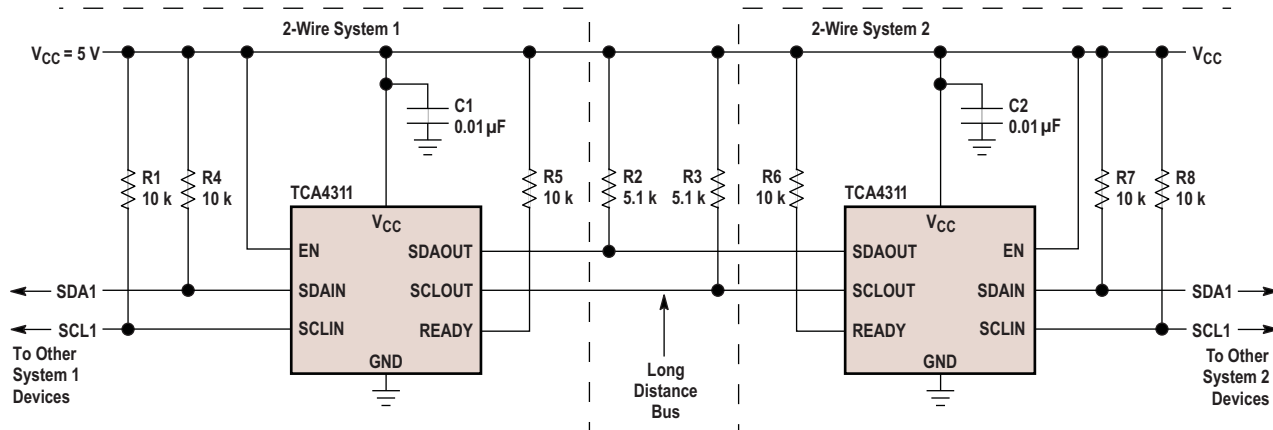
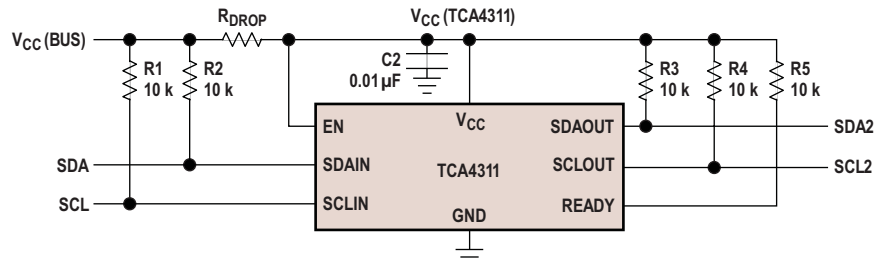

Figure 11. Repeater/Bus Extender Application

## Typical Application (continued)

### 8.1.3 Systems With Disparate Supply Voltages

In large 2-wire systems, the  $V_{CC}$  voltages seen by devices at various points in the system can differ by a few hundred millivolts or more. This situation is well modeled by a series resistor in the  $V_{CC}$  line, as shown in Figure 12. For proper operation of the TCA4311, make sure that  $V_{CC(BUS)} \geq V_{CC(TCA4311)} - 0.5\text{ V}$ .



**Figure 12. System With Disparate  $V_{CC}$  Voltages**

### 8.1.4 Design Requirements

#### 8.1.4.1 Input to Output Offset Voltage

When a logic low voltage,  $V_{LOW1}$ , is driven on any of the TCA4311's data or clock pins, the TCA4311 regulates the voltage on the other side of the chip (call it  $V_{LOW2}$ ) to a slightly higher voltage, as directed by the following equation:

$$V_{LOW2} = V_{LOW1} + 75\text{ mV} + (V_{CC}/R) \times 100$$

where  $R$  is the bus pullup resistance in ohms ( $\Omega$ ). For example, if a device is forcing SDAOUT to 10 mV where  $V_{CC} = 3.3\text{ V}$  and the pullup resistor  $R$  on SDAIN is 10 k $\Omega$ , then the voltage on SDAIN =  $10 + 75 + (3.3/10000) \times 100 = 118\text{ mV}$ . See the [Typical Characteristics](#) section for curves showing the offset voltage as a function of  $V_{CC}$  and  $R$ .

#### 8.1.4.2 Propagation Delays

During a rising edge, the rise-time on each side is determined by the combined pullup current of the TCA4311 boost current and the bus resistor and the equivalent capacitance on the line. If the pullup currents are the same, a difference in rise-time occurs which is directly proportional to the difference in capacitance between the two sides. This effect is displayed in Figure 13 for  $V_{CC} = 3.3\text{ V}$  and a 10-k $\Omega$  pullup resistor on each side (50 pF on one side and 150 pF on the other). Since the output side has less capacitance than the input, it rises faster and the effective  $t_{PLH}$  is negative.

There is a finite propagation delay,  $t_{PHL}$ , through the connection circuitry for falling waveforms. Figure 14 shows the falling edge waveforms for the same  $V_{CC}$ , pullup resistors and equivalent capacitance conditions as used in Figure 13. An external NMOS device pulls down the voltage on the side with 150 pF capacitance; the TCA4311 pulls down the voltage on the opposite side, with a delay of 55 ns. This delay is always positive and is a function of supply voltage, temperature and the pullup resistors and equivalent bus capacitances on both sides of the bus. The [Typical Characteristics](#) section shows  $t_{PHL}$  as a function of temperature and voltage for 10-k $\Omega$  pullup resistors and 100 pF equivalent capacitance on both sides of the part. By comparison with Figure 14, the  $V_{CC} = 3.3\text{ V}$  curve shows that increasing the capacitance from 50 pF to 100 pF results in a  $t_{PHL}$  increase from 55 ns to 75 ns. Larger output capacitances translate to longer delays (up to 150 ns). Users must quantify the difference in propagation times for a rising edge versus a falling edge in their systems and adjust setup and hold times accordingly.

## Typical Application (continued)

### 8.1.5 Detailed Design Procedure

#### 8.1.5.1 Resistor Pull-Up Value Selection

The system pullup resistors must be strong enough to provide a positive slew rate of 1.25 V/μs on the SDA and SCL pins, in order to activate the boost pullup currents during rising edges. Choose maximum resistor value R using the formula:

$$R \leq (V_{CC(MIN)} - 0.6) (800,000) / C$$

where R is the pullup resistor value in ohms,  $V_{CC(MIN)}$  is the minimum  $V_{CC}$  voltage and C is the equivalent bus capacitance in picofarads (pF).

In addition, regardless of the bus capacitance, always choose  $R \leq 16 \text{ k}\Omega$  for  $V_{CC} = 5.5 \text{ V}$  maximum,  $R \leq 24 \text{ k}\Omega$  for  $V_{CC} = 3.6 \text{ V}$  maximum. The start-up circuitry requires logic high voltages on SDAOUT and SCLOUT to connect the backplane to the card, and these pullup values are needed to overcome the precharge voltage.

### 8.1.6 Application Curves

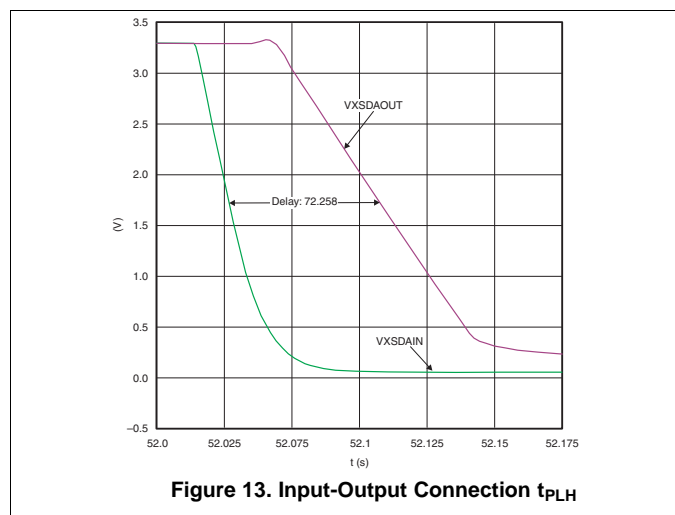

Figure 13. Input-Output Connection  $t_{PHL}$

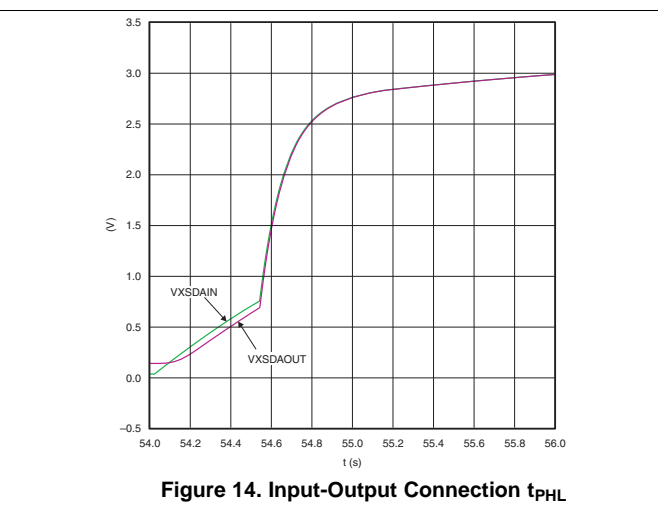

Figure 14. Input-Output Connection  $t_{PHL}$

## 9 Device and Documentation Support

### 9.1 Trademarks

CompactPCI is a trademark of PCI Industrial Computer Manufacturers Group. All other trademarks are the property of their respective owners.

### 9.2 Electrostatic Discharge Caution



These devices have limited built-in ESD protection. The leads should be shorted together or the device placed in conductive foam during storage or handling to prevent electrostatic damage to the MOS gates.

### 9.3 Glossary

[SLYZ022](#) — TI Glossary.

This glossary lists and explains terms, acronyms, and definitions.

## 10 Mechanical, Packaging, and Orderable Information

The following pages include mechanical, packaging, and orderable information. This information is the most current data available for the designated devices. This data is subject to change without notice and revision of this document. For browser-based versions of this data sheet, refer to the left-hand navigation.



**PACKAGING INFORMATION**

| Orderable Device | Status<br>(1) | Package Type | Package Drawing | Pins | Package Qty | Eco Plan<br>(2)         | Lead/Ball Finish<br>(6) | MSL Peak Temp<br>(3) | Op Temp (°C) | Device Marking<br>(4/5) | Samples |
|------------------|---------------|--------------|-----------------|------|-------------|-------------------------|-------------------------|----------------------|--------------|-------------------------|---------|
| TCA4311D         | NRND          | SOIC         | D               | 8    | 75          | Green (RoHS & no Sb/Br) | CU NIPDAU               | Level-1-260C-UNLIM   | -40 to 85    | PR311                   |         |
| TCA4311DGKR      | NRND          | VSSOP        | DGK             | 8    | 2500        | Green (RoHS & no Sb/Br) | CU NIPDAU               | Level-1-260C-UNLIM   | -40 to 85    | 3JS                     |         |
| TCA4311DR        | NRND          | SOIC         | D               | 8    | 2500        | Green (RoHS & no Sb/Br) | CU NIPDAU               | Level-1-260C-UNLIM   | -40 to 85    | PR311                   |         |

(1) The marketing status values are defined as follows:

**ACTIVE:** Product device recommended for new designs.

**LIFEBUY:** TI has announced that the device will be discontinued, and a lifetime-buy period is in effect.

**NRND:** Not recommended for new designs. Device is in production to support existing customers, but TI does not recommend using this part in a new design.

**PREVIEW:** Device has been announced but is not in production. Samples may or may not be available.

**OBSOLETE:** TI has discontinued the production of the device.

(2) **RoHS:** TI defines "RoHS" to mean semiconductor products that are compliant with the current EU RoHS requirements for all 10 RoHS substances, including the requirement that RoHS substance do not exceed 0.1% by weight in homogeneous materials. Where designed to be soldered at high temperatures, "RoHS" products are suitable for use in specified lead-free processes. TI may reference these types of products as "Pb-Free".

**RoHS Exempt:** TI defines "RoHS Exempt" to mean products that contain lead but are compliant with EU RoHS pursuant to a specific EU RoHS exemption.

**Green:** TI defines "Green" to mean the content of Chlorine (Cl) and Bromine (Br) based flame retardants meet JS709B low halogen requirements of <=1000ppm threshold. Antimony trioxide based flame retardants must also meet the <=1000ppm threshold requirement.

(3) MSL, Peak Temp. - The Moisture Sensitivity Level rating according to the JEDEC industry standard classifications, and peak solder temperature.

(4) There may be additional marking, which relates to the logo, the lot trace code information, or the environmental category on the device.

(5) Multiple Device Markings will be inside parentheses. Only one Device Marking contained in parentheses and separated by a "~" will appear on a device. If a line is indented then it is a continuation of the previous line and the two combined represent the entire Device Marking for that device.

(6) Lead/Ball Finish - Orderable Devices may have multiple material finish options. Finish options are separated by a vertical ruled line. Lead/Ball Finish values may wrap to two lines if the finish value exceeds the maximum column width.

**Important Information and Disclaimer:** The information provided on this page represents TI's knowledge and belief as of the date that it is provided. TI bases its knowledge and belief on information provided by third parties, and makes no representation or warranty as to the accuracy of such information. Efforts are underway to better integrate information from third parties. TI has taken and continues to take reasonable steps to provide representative and accurate information but may not have conducted destructive testing or chemical analysis on incoming materials and chemicals. TI and TI suppliers consider certain information to be proprietary, and thus CAS numbers and other limited information may not be available for release.

In no event shall TI's liability arising out of such information exceed the total purchase price of the TI part(s) at issue in this document sold by TI to Customer on an annual basis.

## TAPE AND REEL INFORMATION



### QUADRANT ASSIGNMENTS FOR PIN 1 ORIENTATION IN TAPE



\*All dimensions are nominal

| Device      | Package Type | Package Drawing | Pins | SPQ  | Reel Diameter (mm) | Reel Width W1 (mm) | A0 (mm) | B0 (mm) | K0 (mm) | P1 (mm) | W (mm) | Pin1 Quadrant |
|-------------|--------------|-----------------|------|------|--------------------|--------------------|---------|---------|---------|---------|--------|---------------|
| TCA4311DGKR | VSSOP        | DGK             | 8    | 2500 | 330.0              | 12.4               | 5.3     | 3.4     | 1.4     | 8.0     | 12.0   | Q1            |
| TCA4311DR   | SOIC         | D               | 8    | 2500 | 330.0              | 12.4               | 6.4     | 5.2     | 2.1     | 8.0     | 12.0   | Q1            |

**TAPE AND REEL BOX DIMENSIONS**

\*All dimensions are nominal

| Device      | Package Type | Package Drawing | Pins | SPQ  | Length (mm) | Width (mm) | Height (mm) |
|-------------|--------------|-----------------|------|------|-------------|------------|-------------|
| TCA4311DGKR | VSSOP        | DGK             | 8    | 2500 | 358.0       | 335.0      | 35.0        |
| TCA4311DR   | SOIC         | D               | 8    | 2500 | 367.0       | 367.0      | 35.0        |



D0008A

# PACKAGE OUTLINE

SOIC - 1.75 mm max height

SMALL OUTLINE INTEGRATED CIRCUIT



4214825/C 02/2019

## NOTES:

- Linear dimensions are in inches [millimeters]. Dimensions in parenthesis are for reference only. Controlling dimensions are in inches. Dimensioning and tolerancing per ASME Y14.5M.
- This drawing is subject to change without notice.
- This dimension does not include mold flash, protrusions, or gate burrs. Mold flash, protrusions, or gate burrs shall not exceed  $.006$  [0.15] per side.
- This dimension does not include interlead flash.
- Reference JEDEC registration MS-012, variation AA.

# EXAMPLE BOARD LAYOUT

D0008A

SOIC - 1.75 mm max height

SMALL OUTLINE INTEGRATED CIRCUIT



LAND PATTERN EXAMPLE  
 EXPOSED METAL SHOWN  
 SCALE:8X



SOLDER MASK DETAILS

4214825/C 02/2019

NOTES: (continued)

- 6. Publication IPC-7351 may have alternate designs.
- 7. Solder mask tolerances between and around signal pads can vary based on board fabrication site.

# EXAMPLE STENCIL DESIGN

D0008A

SOIC - 1.75 mm max height

SMALL OUTLINE INTEGRATED CIRCUIT



SOLDER PASTE EXAMPLE  
BASED ON .005 INCH [0.125 MM] THICK STENCIL  
SCALE:8X

4214825/C 02/2019

NOTES: (continued)

8. Laser cutting apertures with trapezoidal walls and rounded corners may offer better paste release. IPC-7525 may have alternate design recommendations.
9. Board assembly site may have different recommendations for stencil design.

DGK (S-PDSO-G8)

PLASTIC SMALL-OUTLINE PACKAGE



- NOTES:
- A. All linear dimensions are in millimeters.
  - B. This drawing is subject to change without notice.
  - C. Body length does not include mold flash, protrusions, or gate burrs. Mold flash, protrusions, or gate burrs shall not exceed 0.15 per end.
  - D. Body width does not include interlead flash. Interlead flash shall not exceed 0.50 per side.
  - E. Falls within JEDEC MO-187 variation AA, except interlead flash.





- NOTES:
- A. All linear dimensions are in millimeters.
  - B. This drawing is subject to change without notice.
  - C. Publication IPC-7351 is recommended for alternate designs.
  - D. Laser cutting apertures with trapezoidal walls and also rounding corners will offer better paste release. Customers should contact their board assembly site for stencil design recommendations. Refer to IPC-7525 for other stencil recommendations.
  - E. Customers should contact their board fabrication site for solder mask tolerances between and around signal pads.

## IMPORTANT NOTICE AND DISCLAIMER

TI PROVIDES TECHNICAL AND RELIABILITY DATA (INCLUDING DATASHEETS), DESIGN RESOURCES (INCLUDING REFERENCE DESIGNS), APPLICATION OR OTHER DESIGN ADVICE, WEB TOOLS, SAFETY INFORMATION, AND OTHER RESOURCES "AS IS" AND WITH ALL FAULTS, AND DISCLAIMS ALL WARRANTIES, EXPRESS AND IMPLIED, INCLUDING WITHOUT LIMITATION ANY IMPLIED WARRANTIES OF MERCHANTABILITY, FITNESS FOR A PARTICULAR PURPOSE OR NON-INFRINGEMENT OF THIRD PARTY INTELLECTUAL PROPERTY RIGHTS.

These resources are intended for skilled developers designing with TI products. You are solely responsible for (1) selecting the appropriate TI products for your application, (2) designing, validating and testing your application, and (3) ensuring your application meets applicable standards, and any other safety, security, or other requirements. These resources are subject to change without notice. TI grants you permission to use these resources only for development of an application that uses the TI products described in the resource. Other reproduction and display of these resources is prohibited. No license is granted to any other TI intellectual property right or to any third party intellectual property right. TI disclaims responsibility for, and you will fully indemnify TI and its representatives against, any claims, damages, costs, losses, and liabilities arising out of your use of these resources.

TI's products are provided subject to TI's Terms of Sale ([www.ti.com/legal/termsofsale.html](http://www.ti.com/legal/termsofsale.html)) or other applicable terms available either on [ti.com](http://ti.com) or provided in conjunction with such TI products. TI's provision of these resources does not expand or otherwise alter TI's applicable warranties or warranty disclaimers for TI products.

Mailing Address: Texas Instruments, Post Office Box 655303, Dallas, Texas 75265  
Copyright © 2019, Texas Instruments Incorporated