

TCA5600 TCF5600

Universal Microprocessor Power Supply/Controllers

The TCA5600, TCF5600 are versatile power supply control circuits for microprocessor based systems and are mainly intended for automotive applications and battery powered instruments. To cover a wide range of applications, the devices offer high circuit flexibility with a minimum of external components.

Functions included in this IC are a temperature compensated voltage reference, on-chip dc/dc converter, programmable and remote controlled voltage regulator, fixed 5.0 V supply voltage regulator with external PNP power device, undervoltage detection circuit, power-on RESET delay and watchdog feature for safe and hazard free microprocessor operations.

- 6.0 V to 30 V Operation Range
- 2.5 V Reference Voltage Accessible for Other Tasks
- Fixed 5.0 V \pm 4% Microprocessor Supply Regulator Including Current Limitation, Overvoltage Protection and Undervoltage Monitor.
- Programmable 6.0 V to 30 V Voltage Regulator Exhibiting High Peak Current (150mA), Current Limiting and Thermal Protection.
- Two Remote Inputs to Select the Regulator's Operation Mode:
OFF = 5.0 V, 5.0 V Standby
Programmable Output Voltage
- Self-Contained dc/dc Converter Fully Controlled by the Programmable Regulator to Guarantee Safe Operation Under All Working Conditions
- Programmable Power-On RESET Delay
- Watchdog Select Input
- Negative Edge Triggered Watchdog Input
- Low Current Consumption in the V_{CC1} Standby Mode
- All Digital Control Ports are TTL and MOS-Compatible

Applications Include:

- Microprocessor Systems with E²PROMs
- High Voltage Crystal and Plasma Displays
- Decentralized Power Supplies in Computer Telecom Systems

RECOMMENDED OPERATING CONDITIONS

Characteristics	Symbol	Min	Max	Unit
Power Supply Voltage	V_{CC1} V_{CC2}	5.0 5.5	30 30	V
Collector Current	I_C	—	800	mA
Output Voltage	V_{out2}	6.0	30	V
Reference Source Current	I_{ref}	0	2.0	mA

UNIVERSAL MICROPROCESSOR POWER SUPPLY/CONTROLLERS

SEMICONDUCTOR TECHNICAL DATA

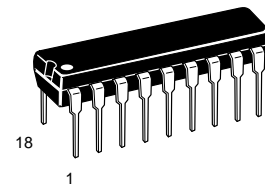

PLASTIC PACKAGE
CASE 707

PIN CONNECTIONS

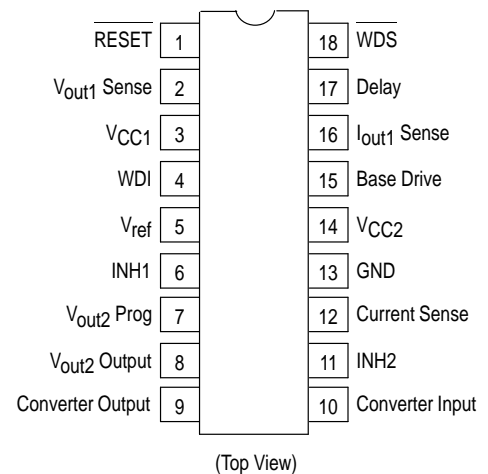

ORDERING INFORMATION

Device	Operating Temperature Range	Package
TCA5600	$T_J = 0^\circ$ to $+125^\circ\text{C}$	Plastic DIP
TCF5600	$T_J = -40^\circ$ to $+150^\circ\text{C}$	Plastic DIP

TCA5600 TCF5600

MAXIMUM RATINGS ($T_A = +25^\circ\text{C}$ [Note 1], unless otherwise noted.)

Rating	Symbol	Value	Unit
Power Supply Voltage (Pin 3,14)	V_{CC1}, V_{CC2}	35	Vdc
Base Drive Current (Pin 15)	I_B	20	mA
Collector Current (Pin 10)	I_C	1.0	A
Forward Rectifier Current (Pin 10 to Pin 9)	I_F	1.0	A
Logic Inputs INH1, INH2, WDS (Pin 6, 11, 18)	V_{INP}	-0.3 V to V_{CC1}	Vdc
Logic Input Current WDI (Pin 4)	I_{WDI}	± 0.5	mA
Output Sink Current RESET (Pin 1)	I_{RES}	10	mA
Analog Inputs (Pin 2) (Pin 7)		-0.3 to 10 -0.3 to 5.0	V
Reference Source Current (Pin 5)	I_{ref}	5.0	mA
Power Dissipation (Note 2) $T_A = +75^\circ\text{C}$ TCA5600 $T_A = +85^\circ\text{C}$ TCF5600	P_D	500 650	mW
Thermal Resistance, Junction-to-Air	$R_{\theta JA}$	100	$^\circ\text{C/W}$
Operating Ambient Temperature Range TCA5600 TCF5600	T_A	0 to +75 -40 to +85	$^\circ\text{C}$
Operating Junction Temperature Range TCA5600 TCF5600	T_J	+125 +150	$^\circ\text{C}$
Storage Temperature Range	T_{stg}	-65 to +150	$^\circ\text{C}$

NOTES: 1. Values beyond which damage may occur.
2. Derate at 10 mW/ $^\circ\text{C}$ for junction temperature above +75 $^\circ\text{C}$ (TCA5600).
Derate at 10 mW/ $^\circ\text{C}$ for junction temperature above +85 $^\circ\text{C}$ (TCF5600).

Representative Block Diagram

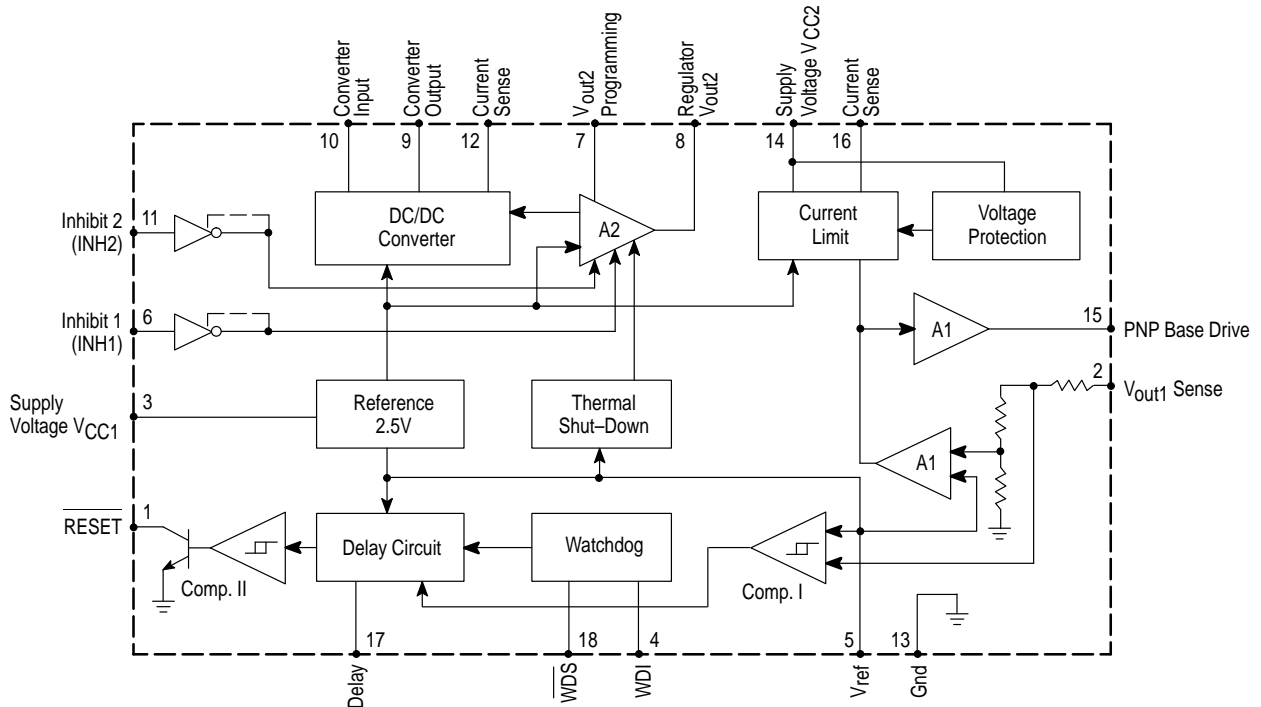

TCA5600 TCF5600

ELECTRICAL CHARACTERISTICS ($V_{CC1} = V_{CC2} = 12\text{ V}$; $T_J = 25^\circ\text{C}$; $I_{\text{ref}} = 0$; $I_{\text{out1}} = 0$ [Note 3]; $R_{\text{SC}} = 0.5\ \Omega$; INH = High
INH2 = High; WDS = High; $I_{\text{out2}} = 0$ [Note 4]; unless otherwise noted.)

Characteristics	Figure	Symbol	Min	Typ	Max	Unit
REFERENCE SECTION						
Nominal Reference Voltage	1	$V_{\text{ref nom}}$	2.42	2.5	2.58	V
Reference Voltage $I_{\text{ref}} = 0.5\text{ mA}$, $T_{\text{low}} \leq T_J \leq T_{\text{high}}$ (Note 5), $6.0\text{ V} \leq V_{CC1} \leq 18\text{ V}$		V_{ref}	2.4	—	2.6	V
Line Regulation ($6.0\text{ V} \leq V_{CC2} \leq 18\text{ V}$)		Reg_{line}	—	2.0	15	mV
Average Temperature Coefficient $T_{\text{low}} \leq T_J \leq T_{\text{high}}$ (Note 5)	2	$\frac{\Delta V_{\text{ref}}}{\Delta T_J}$	—	—	± 0.5	mV/°C
Ripple Rejection Ratio $f = 1.0\text{ kHz}$, $V_{\text{sin}} = 1.0\text{ V}_{\text{pp}}$	3	RR	60	70	—	dB
Output Impedance $0 \leq I_{\text{ref}} \leq 2.0\text{ mA}$		Z_O	—	1.0	—	Ω
Standby Current Consumption $V_{CC2} = \text{Open}$	4	I_{CC1}	—	3.0	—	mA

5.0 V MICROPROCESSOR VOLTAGE REGULATOR SECTION

Nominal Output Voltage		$V_{\text{out1(nom)}}$	4.8	5.0	5.2	V
Output Voltage $5.0\text{ mA} \leq I_{\text{out1}} \leq 300\text{ mA}$, $T_{\text{low}} \leq T_J \leq T_{\text{high}}$ (Note 5) $6.0\text{ V} \leq V_{CC2} \leq 18\text{ V}$	5 6	V_{out1}	4.75	—	5.25	V
Line Regulation ($6.0\text{ V} \leq V_{CC2} \leq 18\text{ V}$)		Reg_{line}	—	10	50	mV
Load Regulation ($5.0\text{ mA} \leq I_{\text{out1}} \leq 300\text{ mA}$)		Reg_{load}	—	20	100	mV
Base Current Drive ($V_{CC2} = 6.0\text{ V}$, $V_{15} = 4.0\text{ V}$)		I_B	10	15	—	mA
Ripple Rejection Ratio $f = 1.0\text{ kHz}$, $V_{\text{sin}} = 1.0\text{ V}_{\text{pp}}$	3	RR	50	65	—	dB
Undervoltage Detection Level ($R_{\text{SC}} = 5.0\ \Omega$)	7	V_{low}	4.5	$0.93 \times V_{\text{out1}}$	—	V
Current Limitation Threshold ($R_{\text{SC}} = 5.0\ \Omega$)		V_{RSC}	210	250	290	mV
Average Temperature Coefficient $T_{\text{low}} \leq T_J \leq T_{\text{high}}$ (Note 5)		$\frac{\Delta V_{\text{out1}}}{\Delta T_J}$	—	—	± 1.0	mV/°C

DC/DC CONVERTER SECTION

Collector Current Detection Level RC = 10 k	High Low	9	$V_{12(\text{H})}$ $V_{12(\text{L})}$	350 —	400 50	450 —	mV
Collector Saturation Voltage $I_C = 600\text{ mA}$ (Note 6)		10	$V_{\text{CE(sat)}}$	—	—	1.6	V
Rectifier Forward Voltage Drop $I_F = 600\text{ mA}$ (Note 6)		11	V_F	—	—	1.4	V

NOTES: 3. The external PNP power transistor satisfies the following minimum specifications:

- $h_{\text{FE}} \geq 60$ at $I_C = 500\text{ mA}$ and $V_{\text{CE}} = 5.0\text{ V}$;
- $V_{\text{CE(sat)}} \leq 300\text{ mV}$ at $I_B = 10\text{ mA}$ and $I_C = 300\text{ mA}$
- 4. Regulator V_{out2} programmed for nominal 24 V output by means of R4, R5 (see Figure 1).
- 5. $T_{\text{low}} = 0^\circ\text{C}$ for TCA5600 $T_{\text{low}} = -40^\circ\text{C}$ for TCF5600
 $T_{\text{high}} = +125^\circ\text{C}$ for TCA5600 $T_{\text{high}} = +150^\circ\text{C}$ for TCF5600
- 6. Pulse tested $t_p \leq 300\ \mu\text{s}$.

TCA5600 TCF5600

ELECTRICAL CHARACTERISTICS ($V_{CC1} = V_{CC2} = 12\text{ V}$; $T_J = 25^\circ\text{C}$; $I_{ref} = 0$; $I_{out1} = 0$ [Note 3]; $R_{SC} = 0.5\ \Omega$; $INH = \text{High}$; $INH2 = \text{High}$; $WDS = \text{High}$; $I_{out2} = 0$ [Note 4]; unless otherwise noted.)

Characteristics	Symbol	Min	Typ	Max	Unit
PROGRAMMABLE VOLTAGE REGULATOR SECTION (Note 6)					
Nominal Output Voltage	$V_{out2(nom)}$	23	24	25	V
Output Voltage (Figure 8) $1.0\text{ mA} \leq I_{out2} \leq 100\text{ mA}$, $T_{low} \leq T_J \leq T_{high}$ (Notes 5, 7)	V_{out2}	22.8	—	25.2	V
Load Regulation $1.0\text{ mA} \leq I_{out2} \leq 100\text{ mA}$ (Note 7)	Reg_{load}	—	40	200	mV
DC Output Current	I_{out2}	100	—	—	mA
Peak Output Current (Internally Limited)	$I_{out2\ p}$	150	200	—	mA
Ripple Rejection Ratio $f = 20\text{ kHz}$, $V = 0.4\ V_{pp}$	RR	45	55	—	dB
Output Voltage (Fixed 5.0 V) $1.0\text{ mA} \leq I_{out2} \leq 20\text{ mA}$, $T_{low} \leq T_J \leq T_{high}$ $INH1 = \text{HIGH}$ (Note 5)	$V_{out2(5.0\ V)}$	4.75	—	5.25	V
Off State Output Impedance ($INH2 = \text{Low}$)	R_{out1}	—	10	—	k Ω
Average Temperature Coefficient $T_{low} \leq T_J \leq T_{high}$ (Note 5)	$\frac{\Delta V_{out2}}{\Delta T_J V_{out2}}$	—	—	± 0.25	mV/ $^\circ\text{C V}$

WATCHDOG AND RESET CIRCUIT SECTION

Threshold Voltage High (Static) Low	$V_{C5(H)}$ $V_{C5(L)}$	—	2.5 1.0	—	V
Current Source $T_{low} \leq T_J \leq T_{high}$ (Note 5) Power-Up RESET Watchdog Time Out Watchdog RESET	I_{C5}	-1.8	-2.5 $5 \times I_{C5}$ $-50 \times I_{C5}$	-3.2	μA
Watchdog Input Voltage Swing	V_{WDI}	—	—	± 5.5	V
Watchdog Input Impedance	r_i	12	15	—	k Ω
Watchdog Reset Pulse Width ($C8 = 1.0\text{ nF}$) (Note 9)	t_p	—	—	10	μs

DIGITAL PORTS: WDS, INH 1, INH 2, RESET (Note 8)

Input Voltage Range	V_{INP}	—	—	-0.3 to V_{CC1}	V
Input High Current $2.0\text{ V} \leq V_{IH} \leq 5.5\text{ V}$ $5.5\text{ V} \leq V_{IH} \leq V_{CC1}$	I_{IH}	—	—	100 150	μA
Input Low Current $-0.3\text{ V} \leq V_{IL} \leq 0.8\text{ V}$ for $INH1$, $INH2$, $-0.3\text{ V} \leq V_{IL} \leq 0.4\text{ V}$ for WDS	I_{IL}	—	—	-100	μA
Leakage Current Immunity ($INH2$, High "Z" State) (Figure 12)	I_Z	± 20	—	—	μA
Output Low Voltage RESET ($I_{OL} = 6.0\text{ mA}$)	V_{OL}	—	—	0.4	V
Output High Voltage RESET ($V_{OH} = 5.5\text{ V}$)	V_{OH}	—	—	20	μA

NOTES: 3. The external PNP power transistor satisfies the following minimum specifications:

- $h_{FE} \geq 60$ at $I_C = 500\text{ mA}$ and $V_{CE} = 5.0\text{ V}$;
- $V_{CE(sat)} \leq 300\text{ mV}$ at $I_B = 10\text{ mA}$ and $I_C = 300\text{ mA}$
- 4. Regulator V_{out2} programmed for nominal 24 V output by means of R4, R5 (see Figure 1).
- 5. $T_{low} = 0^\circ\text{C}$ for TCA5600 $T_{low} = -40^\circ\text{C}$ for TCF5600
 $T_{high} = +125^\circ\text{C}$ for TCA5600 $T_{high} = +150^\circ\text{C}$ for TCF5600
- 6. $V_g = 28\text{ V}$, $INH1 = \text{LOW}$ for this Electrical Characteristic section unless otherwise noted.
- 7. Pulse tested $t_p \leq 300\ \mu\text{s}$.
- 8. Temperature range $T_{low} \leq T_J \leq T_{high}$ applies to this Electrical Characteristics section.
- 9. For test purposes, a negative pulse is applied to Pin 4 ($-2.5\text{ V} \geq V_4 \geq -5.5\text{ V}$).

TCA5600 TCF5600

Figure 1. Reference Voltage versus Supply Voltage

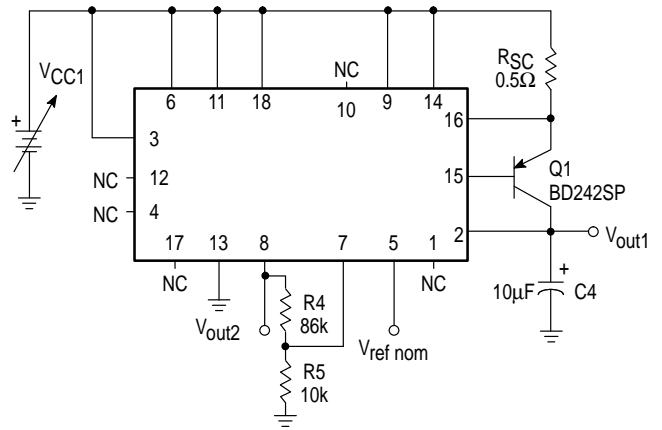
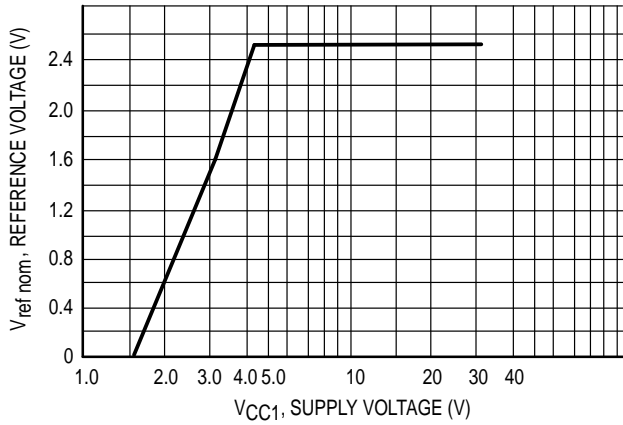

Figure 2. Reference Stability versus Temperature

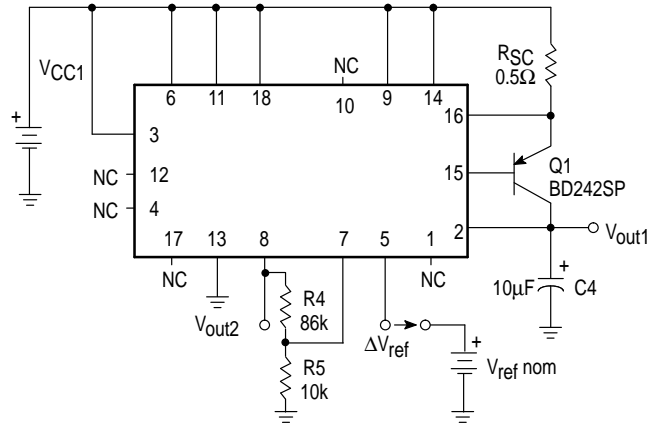
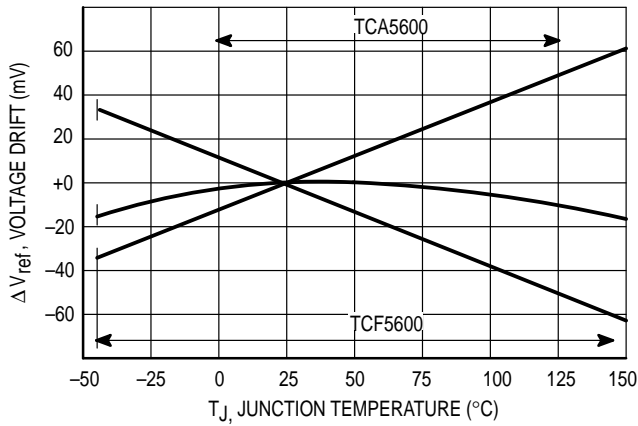
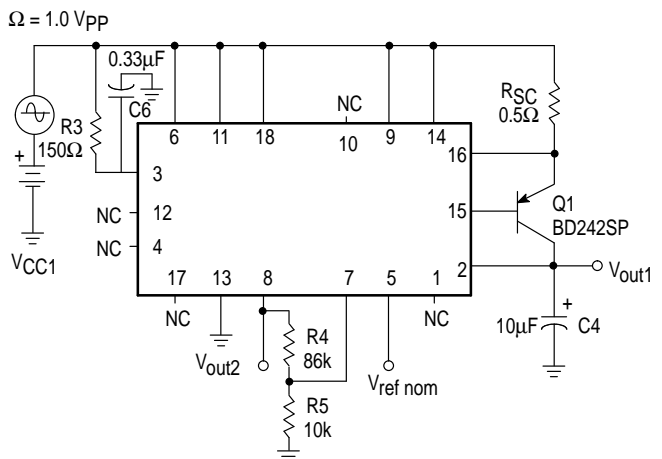
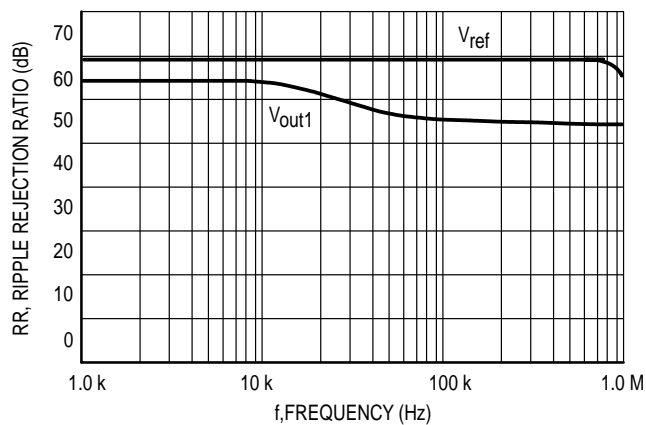

Figure 3. Ripple Rejection versus Frequency



TCA5600 TCF5600

Figure 4. Standby Current versus Supply Voltage

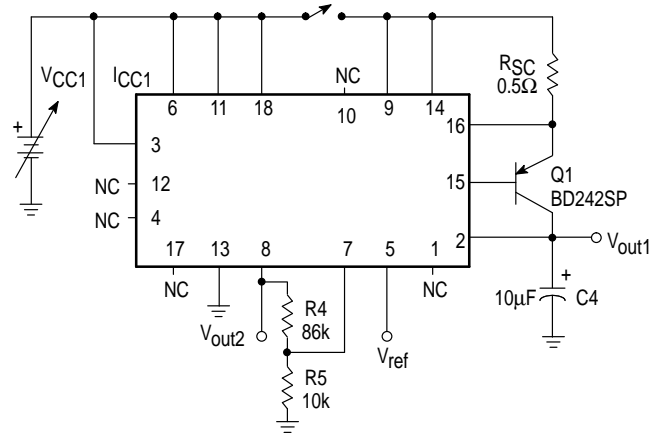
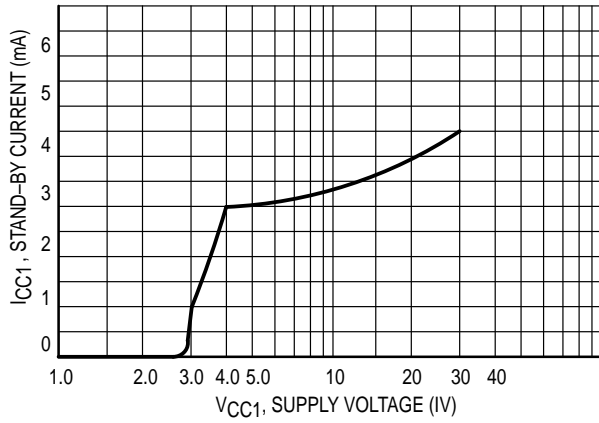

Figure 5. Power-Up Behavior of the 5.0 V Regulator

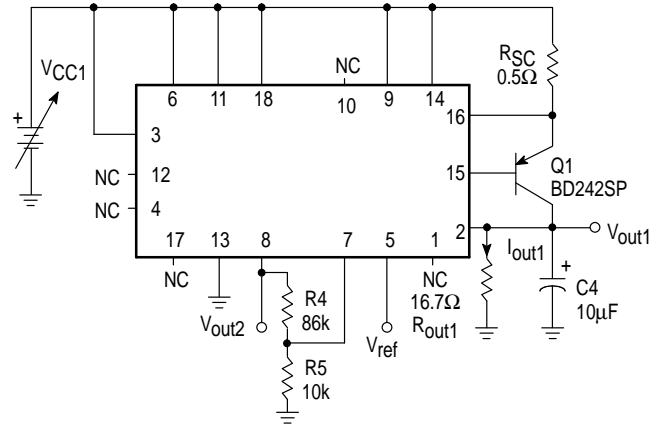
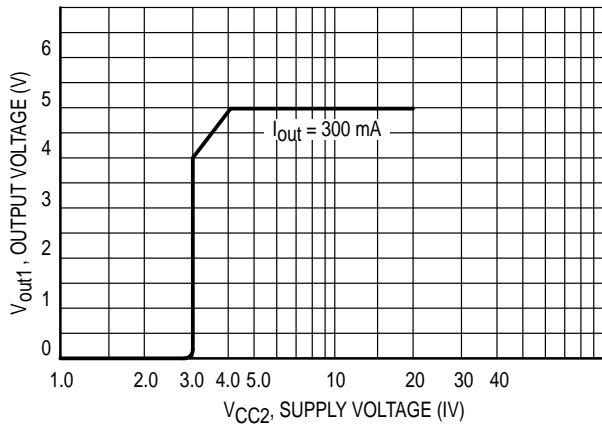
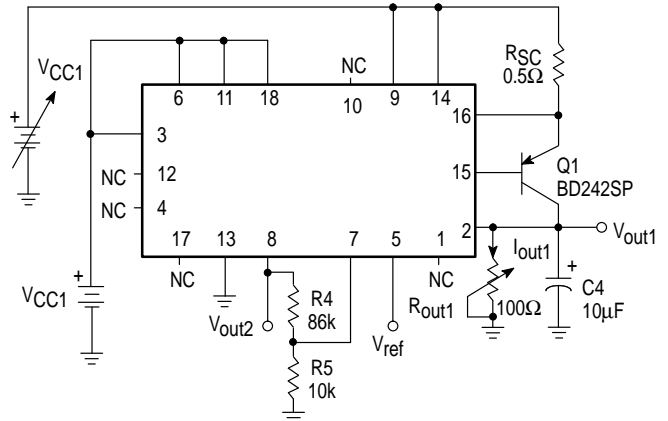
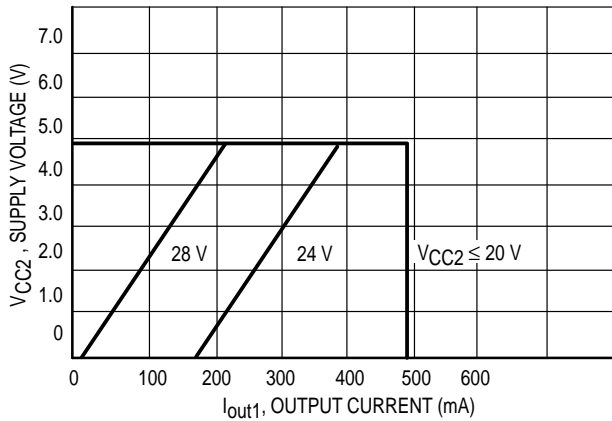

Figure 6. Foldback Characteristics of the 5.0 V Regulator



TCA5600 TCF5600

Figure 10. Power Switch Characteristics

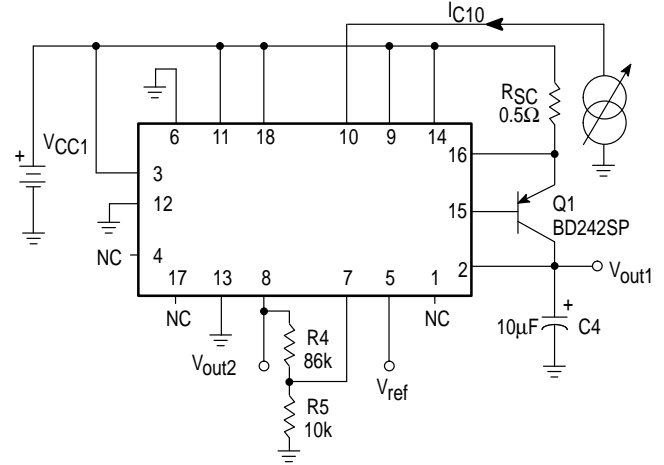
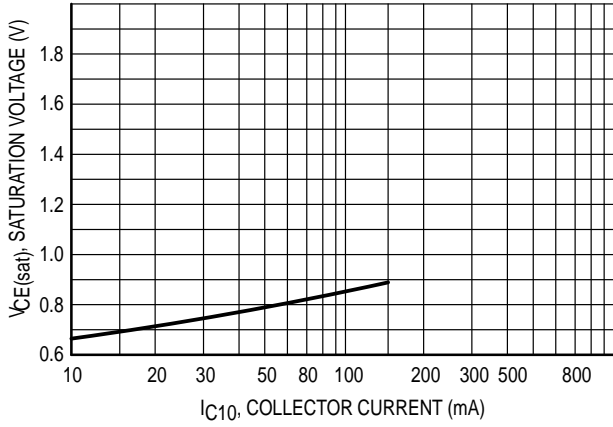

Figure 11. Rectifier Characteristics

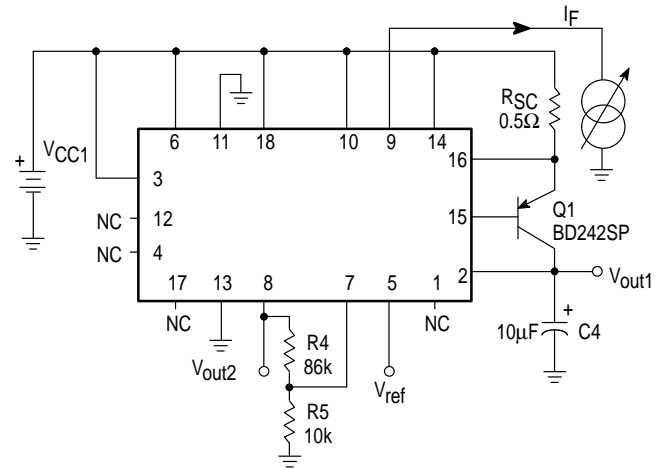
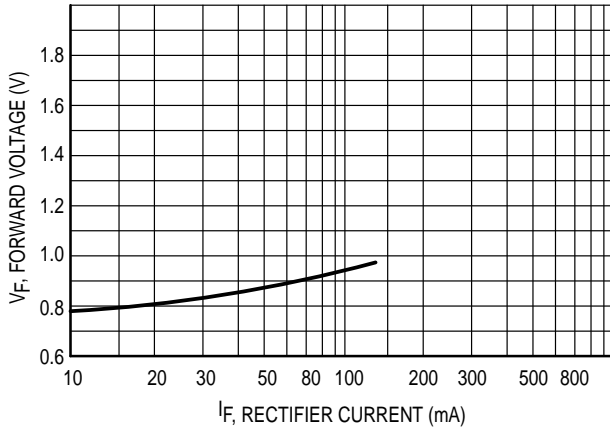
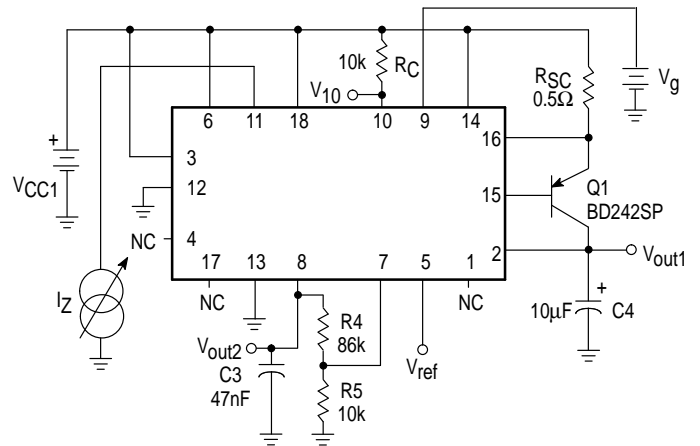
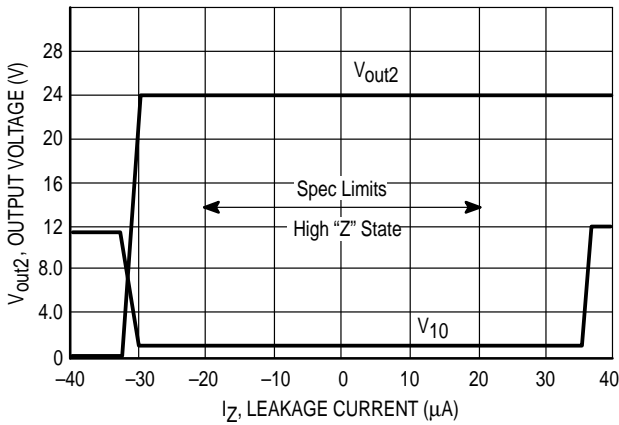

Figure 12. INH 2 Leakage Current Immunity



TCA5600 TCF5600

APPLICATIONS INFORMATION

(See Figure 18)

Voltage Reference (V_{ref})

The voltage reference V_{ref} is based upon a highly stable bandgap voltage reference and is accessible on Pin 5 for additional tasks. This circuit part has its own supply connection on Pin 3 and is, therefore, able to operate in standby mode. The RC network R3, C6 improves the ripple rejection on both regulators.

DC/DC Converter

The dc/dc converter performs according to the flyback principle and does not need a time base circuit. The maximum coil current is well defined by means of the current sensing resistor R1 under all working conditions (startup phase, circuit overload, wide supply voltage range and extreme load current change). Figure 13 shows the Simplified Converter Schematic.

Figure 13. Simplified Converter Schematic

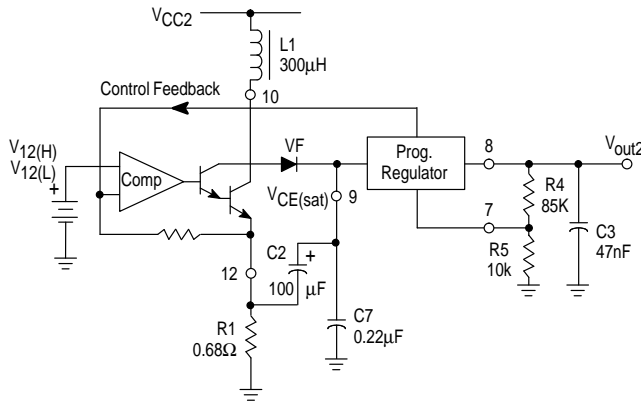

A simplified method on “how to calculate the coil inductance” is given below. The operation point at minimum supply voltage (V_{CC2}) and max. output current (I_{out2}) for a fixed output voltage (V_{out2}) determines the coil data. Figure 14 shows the typical voltage and current waveforms on the coil $L1$ (coil losses neglected).

Equations (1) and (2) yield the respective coil voltage $V_L -$ and $V_L +$ (see Figure 14):

$$\begin{aligned} V_{L+} &= V_{out2} + \Delta V(\text{Pin } 9 - \text{Pin } 8) + V_F - V_{CC2} & (1) \\ V_{L-} &= V_{CC2} - V_{CE(sat)} - V_{12(H)} & (2) \end{aligned}$$

[$\Delta V(\text{Pin } 9 - \text{Pin } 8)$: input/output voltage drop of the regulator, 2.5 V typical]

[$V_F, V_{CE(sat)}, V_{12(H)}$: see Electrical Characteristics Table]

The time ratio α for the charging time to dumping time is defined by Equation (3):

$$\alpha = \frac{t_1}{t_2} = \frac{V_{L+}}{V_{L-}} \quad (3)$$

Figure 14. Voltage and Current Waveform on the Coil (not to scale)

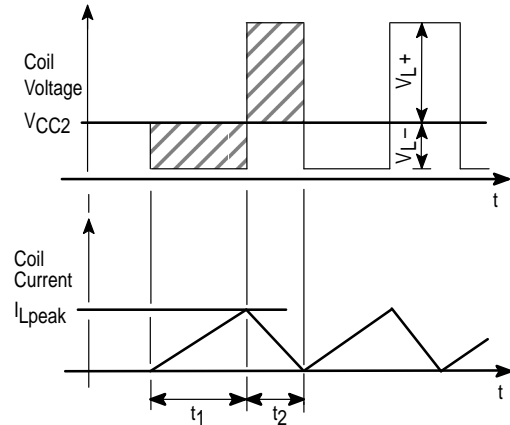

The coil charging time t_1 is found using Equation (4):

$$t_1 = \frac{1}{\left(1 + \frac{1}{\alpha}\right) \cdot f} \quad (4)$$

[f : minimum oscillation frequency which should be chosen above the audio frequency band (e.g. 20 kHz)]

Knowing the dc output current I_{out2} of the programmable regulator, the peak coil current $I_{L(peak)}$ can now be calculated:

$$I_{L(peak)} = 2 \cdot I_{out2} (1 + \alpha) \quad (5)$$

The coil inductance $L1$ of the nonsaturated coil is given by Equation (6):

$$L1 = \frac{t_1}{I_{L(peak)}} (V_{L-}) \quad (6)$$

The formula (6a) yields the current sensing resistor R1 for a defined peak coil current $I_{L(peak)}$:

$$R1 = \frac{V_{12(H)}}{I_{L(peak)}} \quad (6a)$$

In order to limit the by-pass current through capacitor C7 during the energy dumping phase the value $C2 \gg C7$ should be implemented.

For all other operation conditions, the feedback signal from the programmable voltage regulator controls the activity of the converter.

Programmable Voltage Regulator

This series voltage regulator is programmable by the voltage divider R4, R5 for a nominal output voltage of $6.0\text{ V} \leq V_{out2} \leq 30\text{ V}$.

$$R4 = \frac{(V_{out2} - V_{ref\ nom}) \cdot R5}{V_{ref\ nom}} \quad (7)$$

[R5 = 10 k, V_{ref nom} = 2.5 V]

Current limitation and thermal shutdown capability are standard features of this regulator. The voltage drop $\Delta V(P_{in\ 9} - P_{in\ 8})$ across the series pass transistor generates the feedback signal to control the dc/dc converter (see Figure 13).

Control Inputs INH1, INH2

The dc/dc converter and/or the regulator V_{out2} are remote controllable through the TTL, MOS compatible inhibit inputs INH1 and INH2 where the latter is a three-level detector (Logic "0", High Impedance "Z", Logic "1"). Both inputs are set-up to provide the following truth table:

Figure 15. INH1, INH2 TruthTable

Mode	INH1	INH2	V _{out2}	DC/DC
1	0	0	OFF	INT
2	0	High "Z"	V _{out2}	ON
3	0	1	V _{out2}	INT
4	1	0	OFF	INT
5	1	High "Z"	5.0 V	ON
6	1	1	5.0 V	INT

- INT: Intermittent operation of the converter means that the converter operates only if $V_{CC2} < V_{out2}$.
- ON: The converter loads the storage capacitor C2 to its full charge ($V_g = 33\text{ V}$), allowing fast response time of the regulator V_{out2} when addressed by the control software.
- OFF: High impedance (internal resistor 10 k to ground)

Figure 16 represents a typical timing diagram for an E²PROM programming sequence in a microprocessor based system. The High "Z" state enables the dc/dc converter to ramp during t₃ to the voltage V_g at Pin 9 to a high level before the write cycle takes place in the memory.

Figure 16. Typical E²PROM Programming Sequence
(not to scale)

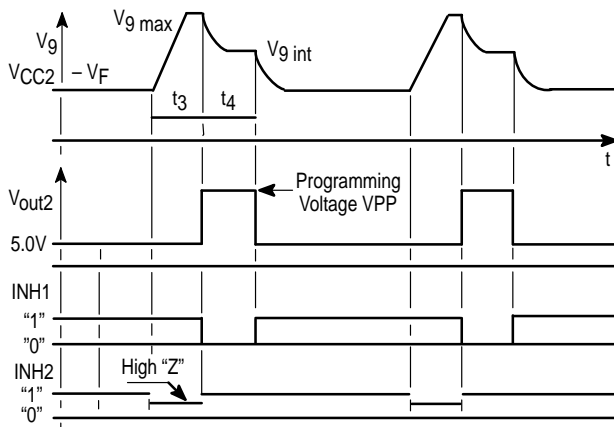

Microprocessor Supply Regulator

Together with an external PNP power transistor (Q1), a 5.0 V supply exhibiting low voltage drop is obtained to power microprocessor systems and auxiliary circuits. Using a power Darlington with adequate heat sink in the output stage boosts the output current I_{out1} above 1.0 A.

The current limitation circuit measures the emitter current of Q1 by means of the sensing resistor, R_{SC}:

$$R_{SC} = \frac{V_{RSC}}{I_E} \quad (8)$$

[I_E: emitter current of Q1]

[V_{RSC}: threshold voltage
(see Electrical Characteristics Table)]

The voltage protection circuit performs a foldback characteristic above a nominal operating voltage, $V_{CC2} \geq 18\text{ V}$.

Delay and Watchdog Circuit

The undervoltage monitor supervises the power supply V_{out1} and releases the delay circuit RESET as soon as the regulator output reaches the microprocessor operating a range [e.g., $V_{low} \geq 0.93 \cdot V_{out1}(\text{nom})$]. The RESET output has an open-collector and may be connected in a "wired-OR" configuration.

The watchdog circuit consists of a retriggerable monostable with a negative edge sensitive control input WDI. The watchdog feature may be disabled by means of the watchdog select input WDS driven to a "1". Figure 17 displays the Typical RESET Timing Diagram.

The commuted current source I_{C5} on Pin 17, threshold voltage V_{C5(L)}, V_{C5(H)} and an external capacitor C5 define the RESET delay and the watchdog timing. The relationship of the timing signals are indicated by the Equations (9) to (11).

$$\overline{\text{RESET}} \text{ delay: } t_d = \frac{C5 \cdot V_{C5(H)}}{|I_{C5}|} \quad (9)$$

$$\text{Watchdog timeout: } t_{wd} = \frac{C5 \cdot (V_{C5(H)} - V_{C5(L)})}{5 \cdot |I_{C5}|} \quad (10)$$

$$\overline{\text{Watchdog RESET:}} t_r = \frac{C5 \cdot (V_{C5(H)} - V_{C5(L)})}{50 \cdot |I_{C5}|} \quad (11)$$

[|I_{C5}, V_{C5(H)}, V_{C5(L)}: see Electrical Characteristics Table]

TCA5600 TCF5600

Figure 17. Typical RESET Timing Diagram (not to scale)

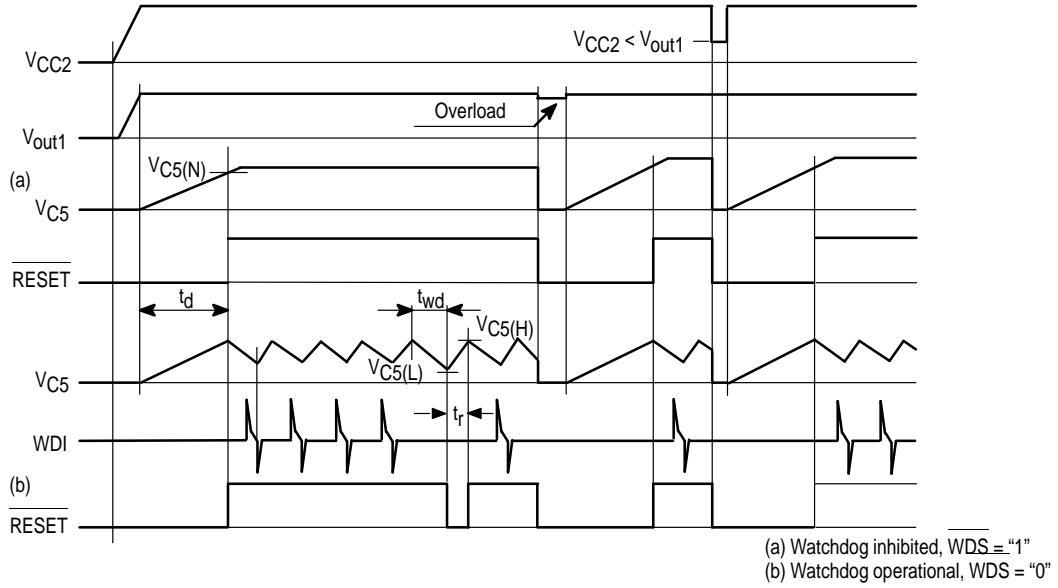
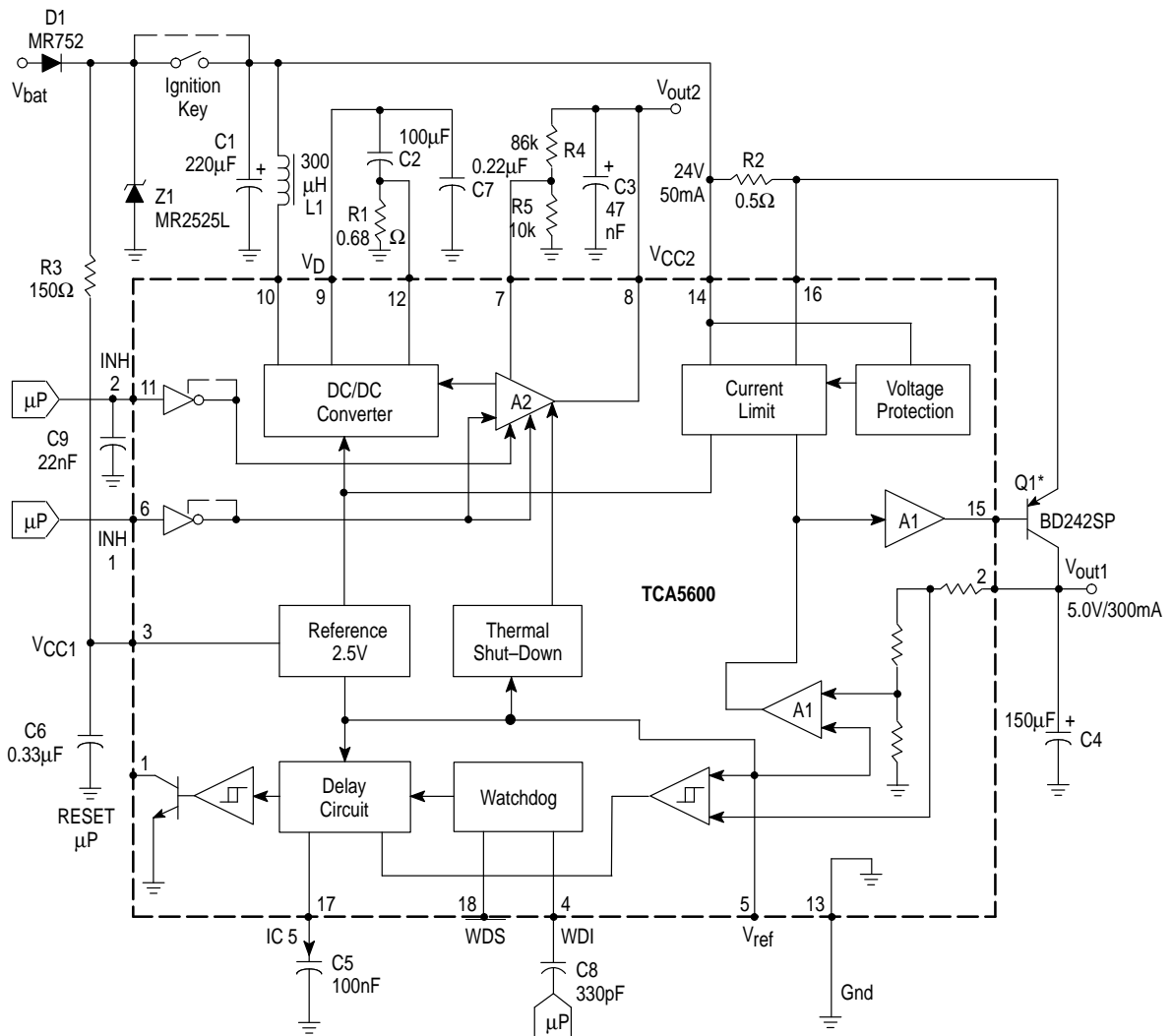

Figure 18. Typical Automotive Application



TCA5600 TCF5600

OUTLINE DIMENSIONS

PLASTIC PACKAGE
CASE 707-02
ISSUE C

NOTES:

1. POSITIONAL TOLERANCE OF LEADS (D), SHALL BE WITHIN 0.25 (0.010) AT MAXIMUM MATERIAL CONDITION, IN RELATION TO SEATING PLANE AND EACH OTHER.
2. DIMENSION L TO CENTER OF LEADS WHEN FORMED PARALLEL.
3. DIMENSION B DOES NOT INCLUDE MOLD FLASH.

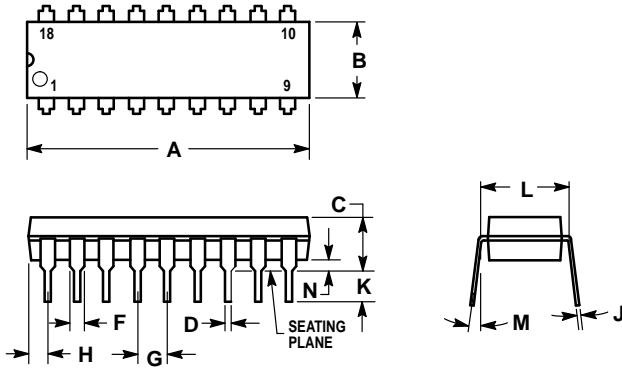

DIM	MILLIMETERS		INCHES	
	MIN	MAX	MIN	MAX
A	22.22	23.24	0.875	0.915
B	6.10	6.60	0.240	0.260
C	3.56	4.57	0.140	0.180
D	0.36	0.56	0.014	0.022
F	1.27	1.78	0.050	0.070
G	2.54 BSC		0.100 BSC	
H	1.02	1.52	0.040	0.060
J	0.20	0.30	0.008	0.012
K	2.92	3.43	0.115	0.135
L	7.62 BSC		0.300 BSC	
M	0° 15°		0° 15°	
N	0.51	1.02	0.020	0.040

Motorola reserves the right to make changes without further notice to any products herein. Motorola makes no warranty, representation or guarantee regarding the suitability of its products for any particular purpose, nor does Motorola assume any liability arising out of the application or use of any product or circuit, and specifically disclaims any and all liability, including without limitation consequential or incidental damages. "Typical" parameters which may be provided in Motorola data sheets and/or specifications can and do vary in different applications and actual performance may vary over time. All operating parameters, including "Typicals" must be validated for each customer application by customer's technical experts. Motorola does not convey any license under its patent rights nor the rights of others. Motorola products are not designed, intended, or authorized for use as components in systems intended for surgical implant into the body, or other applications intended to support or sustain life, or for any other application in which the failure of the Motorola product could create a situation where personal injury or death may occur. Should Buyer purchase or use Motorola products for any such unintended or unauthorized application, Buyer shall indemnify and hold Motorola and its officers, employees, subsidiaries, affiliates, and distributors harmless against all claims, costs, damages, and expenses, and reasonable attorney fees arising out of, directly or indirectly, any claim of personal injury or death associated with such unintended or unauthorized use, even if such claim alleges that Motorola was negligent regarding the design or manufacture of the part. Motorola and  registered trademarks of Motorola, Inc. Motorola, Inc. is an Equal Opportunity/Affirmative Action Employer.

How to reach us:

USA/EUROPE/Locations Not Listed: Motorola Literature Distribution;
P.O. Box 20912; Phoenix, Arizona 85036. 1-800-441-2447 or 602-303-5454

MFAX: RMFAX0@email.sps.mot.com - TOUCHTONE 602-244-6609

INTERNET: <http://Design-NET.com>

JAPAN: Nippon Motorola Ltd.; Tatsumi-SPD-JLDC, 6F Seibu-Butsuryu-Center,
3-14-2 Tatsumi Koto-Ku, Tokyo 135, Japan. 03-81-3521-8315

ASIA/PACIFIC: Motorola Semiconductors H.K. Ltd.; 8B Tai Ping Industrial Park,
51 Ting Kok Road, Tai Po, N.T., Hong Kong. 852-26629298



TCA5600/D

