

TCD1200D

(TENTATIVE)

The TCD1200D is a high sensitive and low dark current 2160 elements image sensor. The sensor can be used for facsimile, imagescanner and OCR. The device contains a row of 2160 photodiodes, which provide a 8 lines/mm (200 DPI) resolution across a B4 size paper. The device is operated by 5V (pulse), and 12V power supply, and mounted in 22 pin Cerdip package with hermetic sealed optical glass window.

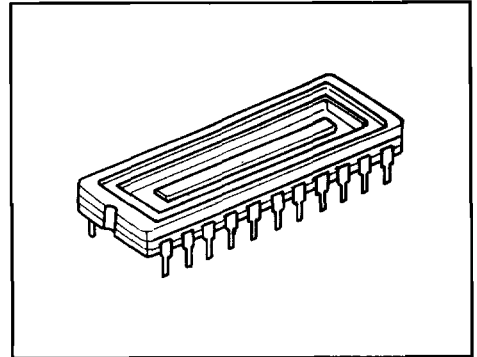

- . Number of Image Sensing Elements: 2160
- . Image Sensing Element Size : 14 μ m by 14 μ m on 14 μ m centers
- . Photo Sensing Region : High sensitive, Low dark current
- . Clock : 2 phase (5V)
- . Package : 22 pin Cerdip

MAXIMUM RATINGS (Note 1)

CHARACTERISTIC	SYMBOL	RATING	UNIT
Clock Pulse Voltage	V_{ϕ}	-0.3~8	V
Shift Pulse Voltage	V_{SH}		
Reset Pulse Voltage	V_{RS}		
Power Supply Voltage	V_{OD}	-0.3~15	
Operating Temperature	T_{opr}	-25~60	$^{\circ}$ C
Storage Temperature	T_{stg}	-40~100	$^{\circ}$ C

(Note 1) All voltage are with respect to SS terminals (Ground).

PIN CONNECTIONS

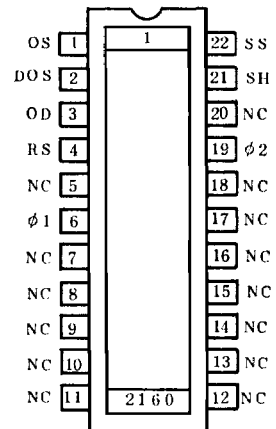

(TOP VIEW)

CIRCUIT DIAGRAM

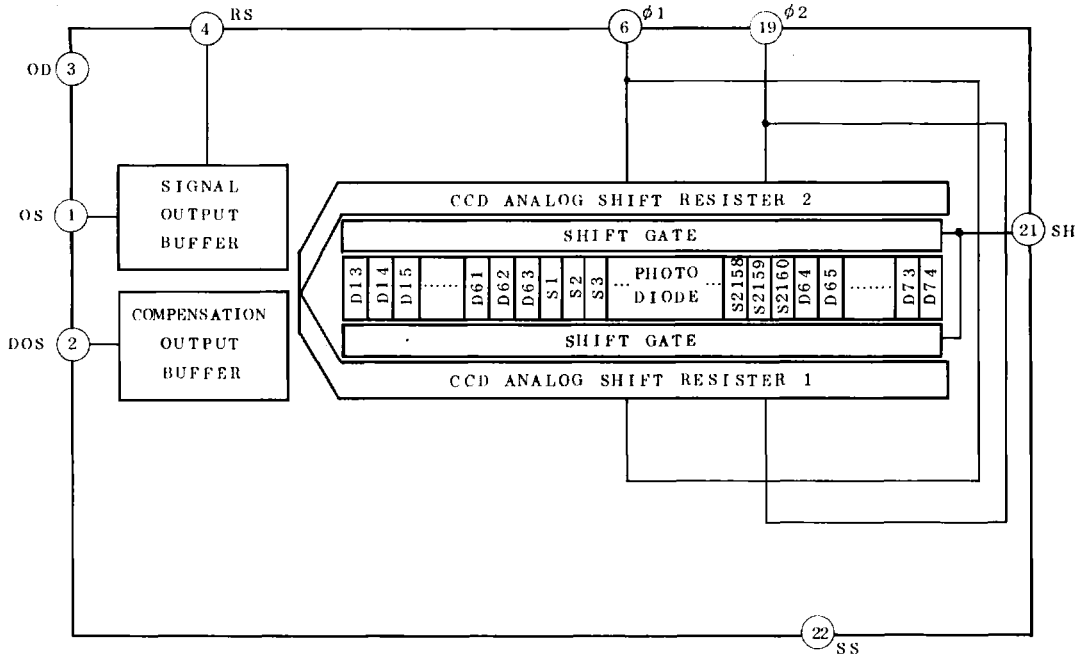

PIN NAMES

$\phi 1$	Clock (Phase 1)
$\phi 2$	Clock (Phase 2)
SH	Shift Gate
RS	Reset Gate
OS	Signal Output
DOS	Compensation Output
OD	Power
SS	Ground
NC	Non Connection

TCD1200D

OPTICAL/ELECTRICAL CHARACTERISTICS

($T_a=25^{\circ}\text{C}$, $V_{OD}=12\text{V}$, $V_{\phi}=V_{SH}=V_{RS}=5\text{V}$ (PULSE), $f_{\phi}=0.5\text{MHz}$, $f_{RS}=1\text{MHz}$, LOAD RESISTANCE=100K Ω)
 t_{INT} (INTEGRATION TIME)=10ms, LIGHT SOURCE=DAYLIGHT FLUORESCENT LAMP)

CHARACTERISTIC	SYMBOL	MIN.	TYP.	MAX.	UNIT	NOTE
Responsivity	R		45		$\ell\text{x}\cdot\text{sec}$	(Note 2)
Photo Response Non Uniformity	PRNU (1)	-	-	10	%	(Note 3)
Photo Response Non Uniformity	PRNU (3)	-	-	8	mV	(Note 10)
Register Imbalance	RI	-	-	3	%	(Note 4)
Saturation Output Voltage	VSAT	1.5	1.7	-	V	(Note 5)
Saturation Exposure	SE		0.037	-	$\ell\text{x}\cdot\text{sec}$	(Note 6)
Dark Signal Voltage	V _{DRK}	-	1	2	mV	(Note 7)
Dark Signal Non Uniformity	DSNU	-	2	3	mV	(Note 7)
DC Power Dissipation	P _D	-	80	120	mW	
Total Transfer Efficiency	TTE	92	-	-	%	
Output Impedance	Z _O	-	-	1	k Ω	
Dynamic Range	DR	-	1700	-	-	(Note 8)
DC Signal Output Voltage	V _O S	3.5	4.5	6.0	V	(Note 9)
DC Compensation Output Voltage	V _D OS	3.5	4.5	6.0	V	(Note 9)
DC Mismatch Voltage	V _O S-V _D OS	-	20	100	mV	

(Note 2) Responsivity for 2854K W-Lamp is 135V/ $\ell\text{x}\cdot\text{sec}$ (Typ.)
 Responsivity for LED (567nm) is 29V/ $\ell\text{x}\cdot\text{sec}$ (Typ.)

(Note 3) Measured at 50% of SE (Typ.)

Definition of PRNU: $\text{PRNU} = \frac{d\bar{x}}{\bar{x}} \times 100$ (%)

Where \bar{x} is average of total signal outputs and $d\bar{x}$ is the maximum deviation from \bar{x} under uniform illumination.

(Note 4) Measured at 50% of SE (Typ.)

RI is defined as follows:

$$\text{RI} = \frac{\sum_{n=1}^{2159} |x_n - x_{n+1}|}{2159 \times \bar{x}} \times 100$$
 (%)

Where x_n and x_{n+1} are signal outputs of each pixel, \bar{x} is average of total signal outputs.

(Note 5) V_{SAT} is defined as minimum Saturation Output Voltage of all effective pixels.

(Note 6) Definition of SE : $SE = \frac{V_{SAT}}{R}$

(Note 7) V_{DRK} is defined as average dark signal voltage of all effective pixels. $DSNU$ is defined as different voltage between V_{DRK} and V_{MDK} , when V_{MDK} is maximum dark voltage.

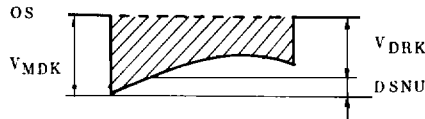

(Note 8) Definition of DR : $DR = \frac{V_{SAT}}{V_{DRK}}$

V_{DRK} is proportional to t_{INT} (Integration time). So the shorter t_{INT} is, the wider DR is.

(Note 9) DC Signal Output Voltage and DC Compensation Output Voltage are defined as follows:

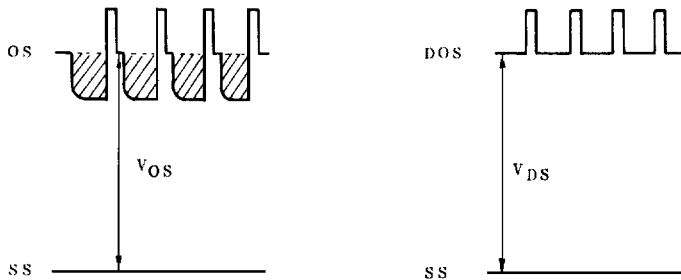

(Note 10) PRNU (3) is defined as maximum Voltage with next pixel. where measured 5% of SE (Typ.)

TCD1200D

OPERATING CONDITION

CHARACTERISTIC		SYMBOL	MIN.	TYP.	MAX.	UNIT
Clock Pulse Voltage	H-Level	V_{ϕ}	4.5	5	5.5	V
	L-Level		0	0.2	0.5	
Shift Pulse Voltage	H-Level	V_{SH}	4.5	5	5.5	V
	L-Level		0	0.2	0.5	
Reset Pulse Voltage	H-Level	V_{RS}	4.5	5	5.5	V
	L-Level		0	0.2	0.5	
Power Supply Voltage		V_{OD}	11.4	12	13	V

CLOCK CHARACTERISTICS (Ta=25°C)

CHARACTERISTIC	SYMBOL	MIN.	TYP.	MAX.	UNIT
Clock Pulse Frequency	f_{ϕ}	-	0.5	1.0	MHz
Reset Pulse Frequency	f_{RS}	-	1.0	2.0	MHz
Clock Capacitance	C_{ϕ}	-	350	400	pF
Shift Gate Capacitance	C_{SH}	-	10		pF
Reset Gate Capacitance	C_{RS}	-	10		pF

TIMING CHART

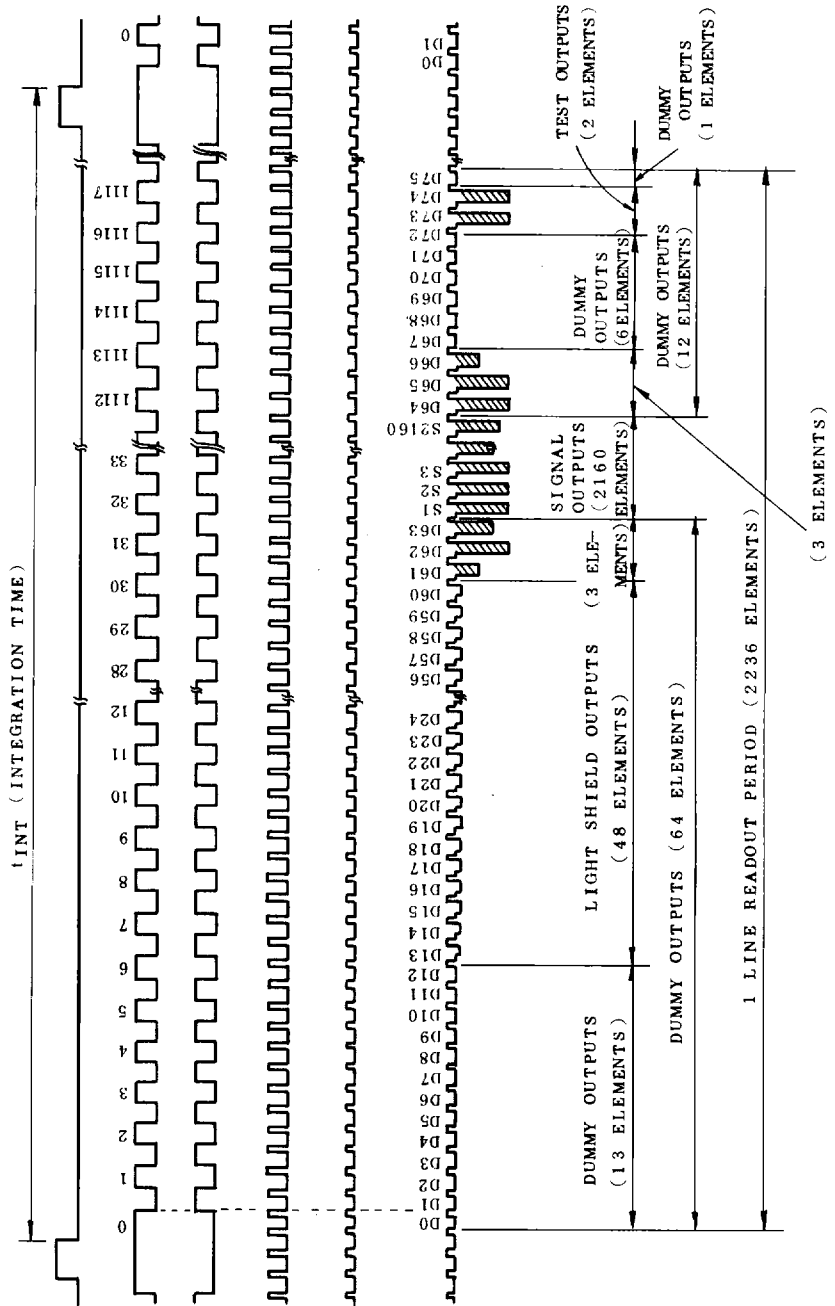

TCD1200

TIMING REQUIREMENTS

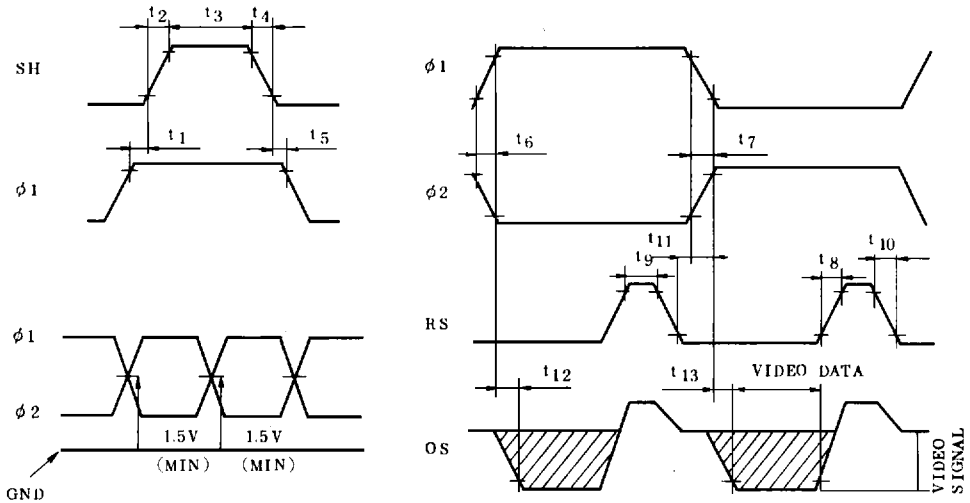

CHARACTERISTIC	SYMBOL	MIN.	TYP. (Note 10)	MAX.	UNIT
Pulse Timing of SH and $\phi 1$	t1, t5	0	100	-	ns
SH Pulse Rise Time, Fall Time	t2, t4	0	50	-	ns
SH Pulse Width	t3	200	1000	-	ns
$\phi 1, \phi 2$ Pulse Rise Time, Fall Time	t6, t7	0	60	100	ns
RS Pulse Rise Time, Fall Time	t8, t10	0	20	-	ns
RS Pulse Width	t9	40	250	-	ns
Pulse Timing of $\phi 1, \phi 2$ and RS	t11	100	125	-	ns
Video Data Delay Time (Note 11)	t12, t13	-	90	-	ns

(Note 10) TYP. is the case of $f_{RS}=1\text{MHz}$

(Note 11) Load Resistance is $100\text{k}\Omega$

TYPICAL PERFORMANCE CURVES

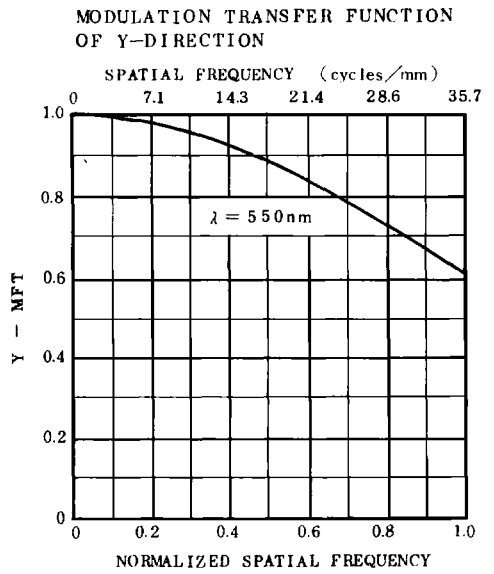
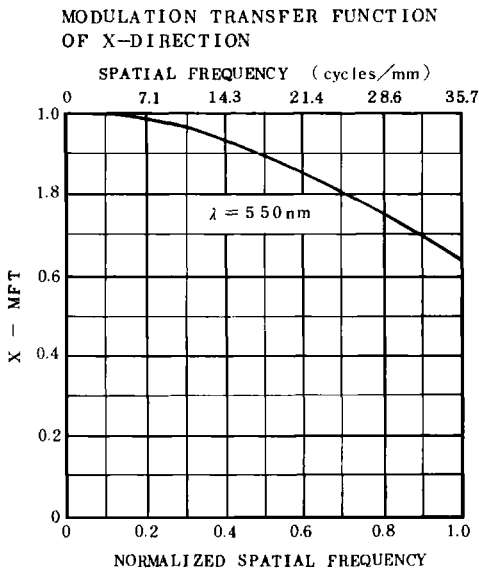
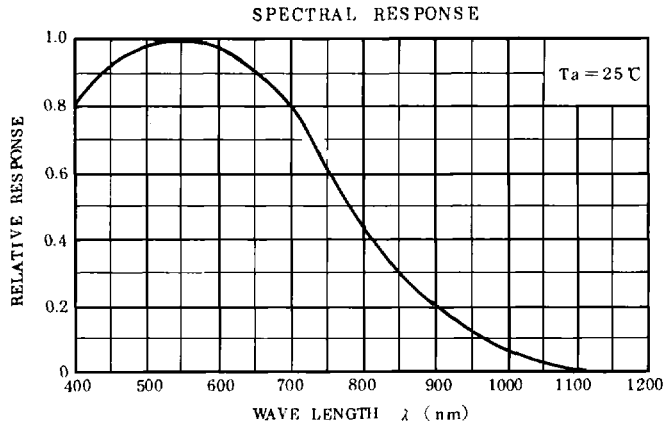

TCD1200D

TYPICAL DRIVE CIRCUIT

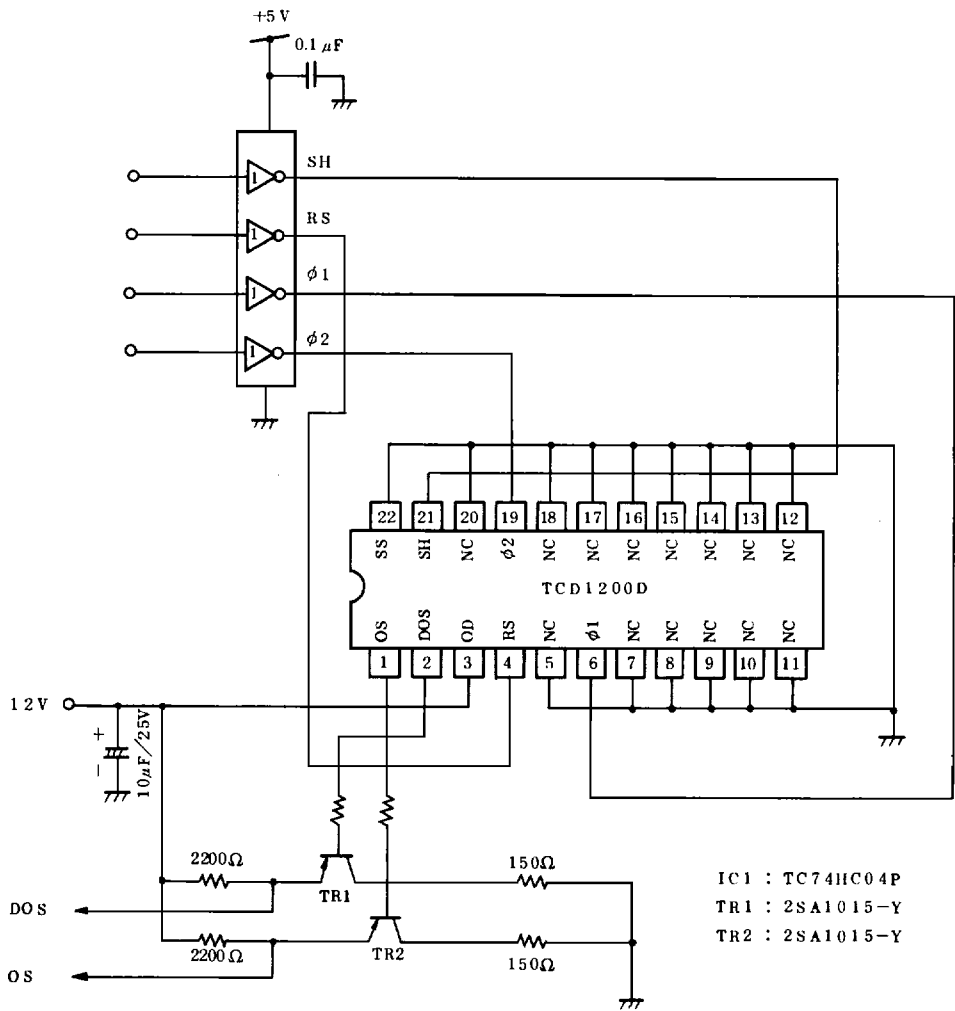

CAUTION**1. Window Glass**

The dust and stain on the glass window of the package degrade optical performance of CCD sensor.

Keep the glass window clean by saturating a cotton swab in alcohol and lightly wiping the surface, and allow the glass to dry, by blowing with filtered dry N₂. Care should be taken to avoid mechanical or thermal shock because the glass window is easily to damage.

2. Electrostatic Breakdown

Store in shorting clip or in conductive foam to avoid electrostatic breakdown.

3. Incident Light

CCD sensor is sensitive to infrared light.

Note that infrared light component degrades resolution and PRNU of CCD sensor.

4. Lead Frame Forming

Since this package is not stout against mechanical stress, you should not reform the lead frame.

We recommend to use a IC-inserter when you assemble to PCB.

PACKAGE OUTLINE

Unit in mm

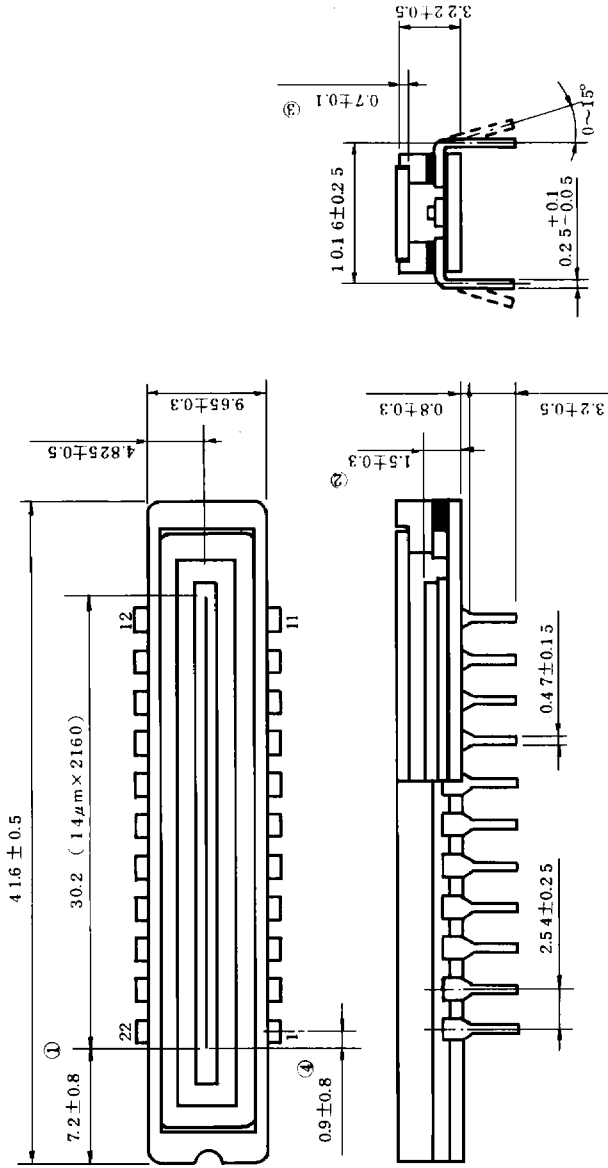

- ① No.1 SENSOR ELEMENT (S1) TO EDGE OF PACKAGE
- ② TOP OF CHIP TO BOTTOM OF PACKAGE
- ③ GLASS THICKNESS (n=1.5)
- ④ No.1 SENSOR ELEMENT (S1) TO CENTER OF 1 pin