

TOSHIBA CCD Linear Image Sensor CCD (Charge Coupled Device)

TCD1706DG

The TCD1706DG is a high sensitive and low dark current 7400 elements CCD image sensor.

The sensor is designed for facsimile, image scanner and OCR.

The device contains a row of 7400 elements photodiodes which provide a 24 lines/mm (600DPI) across a A3 size paper. The device is operated by 5 V (pulse), and 12 V power supply.

Features

- Number of image sensing elements: 7400 elements
- Image sensing element size:
4.7 μm by 4.7 μm on 4.7 μm centers
- Photo sensing region:
High sensitive and low voltage dark signal pn photodiode
- Clock: 2 phase (5 V)
- Package: 22 pin cerdip

Maximum Ratings (Note 1)

Characteristics	Symbol	Rating	Unit
Clock pulse voltage	V_{ϕ}	-0.3 to 8.0	V
Shift pulse voltage	V_{SH}		
Reset pulse voltage	V_{RS}		
Clamp pulse voltage	V_{CP}		
Power supply voltage	V_{OD}	-0.3 to 15	
Operating temperature	T_{opr}	0 to 60	°C
Storage temperature	T_{stg}	-25 to 85	°C

Note 1: All voltage are with respect to SS terminals (ground).

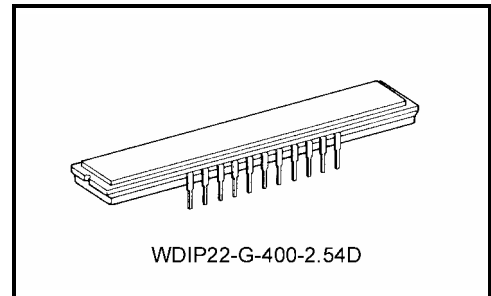

Weight: 4.4 g (typ.)

Pin Connections (top view)

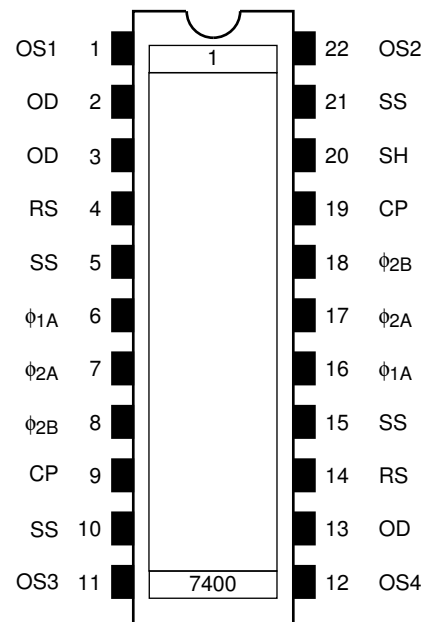

Circuit Diagram

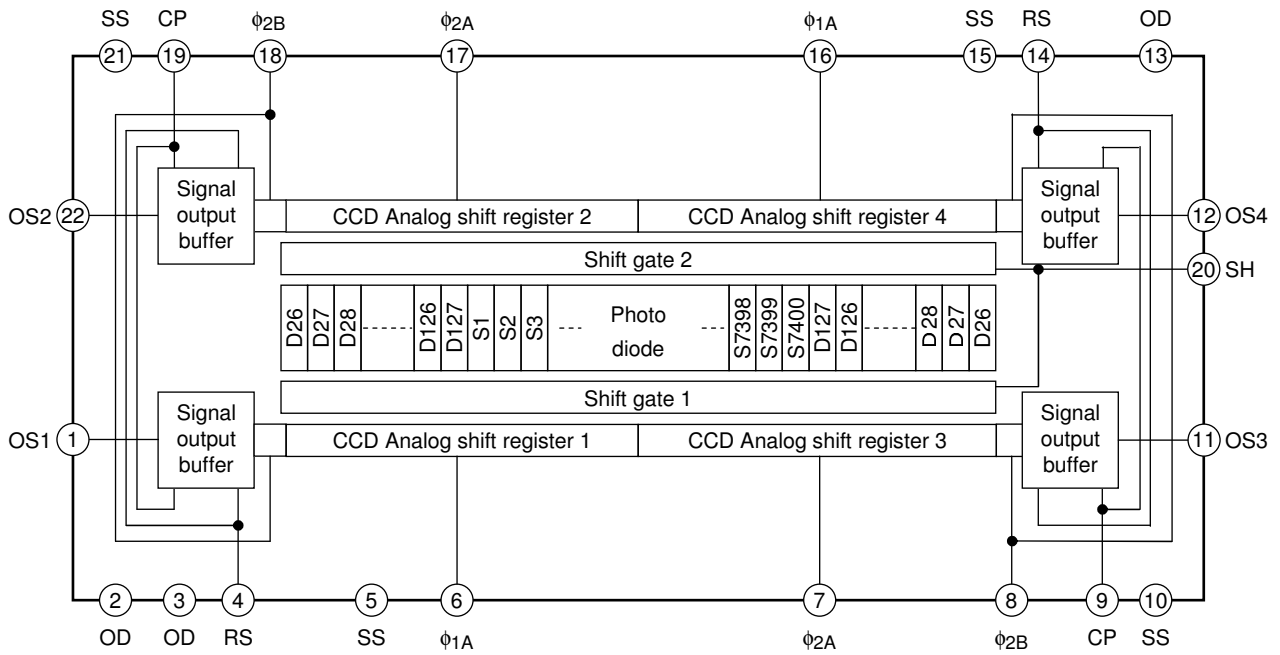

Pin Names

φ1A	Clock (phase 1)
φ2A	Clock (phase 2)
φ2B	Final stage clock (phase 2)
SH	Shift gate
RS	Reset gate
CP	Clamp gate
OS1	Signal output 1
OS2	Signal output 2
OS3	Signal output 3
OS4	Signal output 4
OD	Power
SS	Ground

Optical/Electrical Characteristics

($T_a = 25^\circ\text{C}$, $V_{OD} = 12\text{ V}$, $V_\phi = V_{SH} = V_{RS} = V_{CP} = 5\text{ V (pulse)}$, $f_\phi = 1\text{ MHz}$,
 t_{INT} (Integration Time) = 10 ms, Light Source = Daylight Fluorescent Lamp,
 Load Resistance = 100 k Ω)

Characteristics	Symbol	Min	Typ.	Max	Unit	Note
Sensitivity	R	12	15	18	V/lx·s	
Photo response non uniformity	PRNU	—	3	10	%	(Note 2)
	PRNU (3)	—	6	12	mV	(Note 8)
Saturation output voltage	V_{SAT}	1.5	2.0	—	V	(Note 3)
Saturation exposure	SE	0.08	0.13	—	lx·s	(Note 4)
Dark signal voltage	V_{DRK}	—	1.0	3	mV	(Note 5)
Dark signal non uniformity	DSNU	—	4	10	mV	(Note 5)
DC power dissipation	P_D	—	720	1200	mW	—
Total transfer efficiency	TTE	92	98	—	%	—
Output impedance	Z_O	—	0.2	1	k Ω	—
Dynamic range	DR	—	2000	—	—	(Note 6)
DC signal output voltage	V_{OS}	4.5	6	7.5	V	(Note 7)
DC differential error voltage	$ V_{OSX} - V_{OSY} $	—	—	300	mV	(Note 9)
Random noise	$N_{D\sigma}$	—	1.0	—	mV	(Note 10)

Note 2: Measured at 50% of SE (typ.)

Definition of PRNU:

$$PRNU = \frac{\Delta}{\bar{\chi}} \times 100 (\%)$$

Where $\bar{\chi}$ is average of total signal output and $\Delta\chi$ is maximum deviation from $\bar{\chi}$ under uniform illumination. (Channel 1)

In the case of 1850 elements (Channel 2, Channel 3 and Channel 4), the condition is the same as above too.

Note 3: V_{SAT} is defined as minimum saturation output voltage of all effective pixels.

Note 4: Definition of SE:

$$SE = \frac{V_{SA}}{R} (\text{lx} \cdot \text{s})$$

Note 5: V_{DRK} is defined as average dark signal voltage of all effective pixels.

DSNU is defined as different voltage between V_{DRK} and V_{MDK} when V_{MDK} is maximum dark signal voltage.

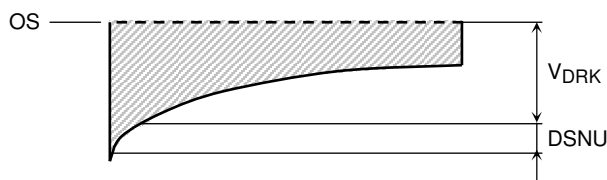

Note 6: Definition of DR: $DR = \frac{V_{SAT}}{V_{DRK}}$

V_{DRK} is proportional to t_{INT} (integration time.)
 so the shorter t_{INT} condition makes wider DR values.

Note 7: DC signal output voltage and DC compensation output voltage are defined as follows.

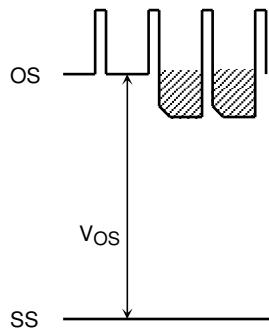

Note 8: PRNU (3) is defined as maximum voltage with next pixel, where measured 5% of SE (typ.)

Note 9: DC differential error voltage is defined as follows :

$$\text{Definition of DC differential error voltage} = |V_{OSX} - V_{OSY}|$$

V_{OSX} : Maximum DC signal output voltage

V_{OSY} : Minimum DC signal output voltage

Note10: Random noise is defined as the standard deviation (sigma) of the output level difference between two adjacent effective pixels under no illumination (i.e. dark condition) calculated by the following procedure.

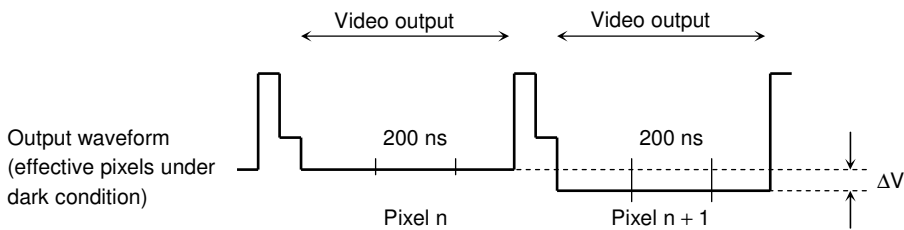

- 1) Two adjacent pixels (pixel n and n + 1) in one reading are fixed as measurement points.
- 2) Each of the output levels at video output periods averaged over 200 nanosecond period to get V_n and V_{n+1} .
- 3) V_{n+1} is subtracted from V_n to get ΔV .
- 4) The standard deviation of ΔV is calculated after procedure 2) and 3) are repeated 30 times (30 readings).

$$\overline{\Delta V} = \frac{1}{30} \sum_{i=1}^{30} |\Delta V_i| \qquad \sigma = \sqrt{\frac{1}{30} \sum_{i=1}^{30} (|\Delta V_i| - \overline{\Delta V})^2}$$

- 5) Procedure 2), 3) and 4) are repeated 10 times to get 10 sigma values.

$$\bar{\sigma} = \frac{1}{10} \sum_{j=1}^{10} \sigma_j$$

- 6) $\bar{\sigma}$ value calculated using the above procedure is observed $\sqrt{2}$ times larger than that measured relative to the ground level. So we specify the random noise as follows.

$$\text{Random noise} = \frac{1}{\sqrt{2}} \bar{\sigma}$$

Operating Condition

Characteristics		Symbol	Min	Typ.	Max	Unit
Clock pulse voltage	"H" Level	$V_{\phi1A}$	4.5	5.0	5.5	V
	"L" Level	$V_{\phi2A}$	0	—	0.5	
Final stage clock voltage	"H" Level	$V_{\phi2B}$	4.5	5.0	5.5	V
	"L" Level		0	—	0.5	
Shift pulse voltage	"H" Level	V_{SH}	4.5	5.0	5.5	V
	"L" Level		0	—	0.5	
Reset pulse voltage	"H" Level	V_{RS}	4.5	5.0	5.5	V
	"L" Level		0	—	0.5	
Clamp pulse voltage	"H" Level	V_{CP}	4.5	5.0	5.5	V
	"L" Level		0	—	0.5	
Power supply voltage		V_{OD}	11.4	12.0	13.0	V

Clock Characteristics (Ta = 25°C)

Characteristics		Symbol	Min	Typ.	Max	Unit
Clock pulse frequency		f_{ϕ}	—	1	25	MHz
Reset pulse frequency		f_{RS}	—	1	25	MHz
Clock capacitance (Note 11)		$C_{\phi1A}$	—	300	—	pF
		$C_{\phi2A}$	—	300	—	
Final stage clock capacitance		$C_{\phi B}$	—	20	—	pF
Shift gate capacitance		C_{SH}	—	50	—	pF
Reset gate capacitance		C_{RS}	—	20	—	pF
Clamp gate capacitance		C_{CP}	—	20	—	pF

Note 11: $V_{OD} = 12\text{ V}$

Timing Chart

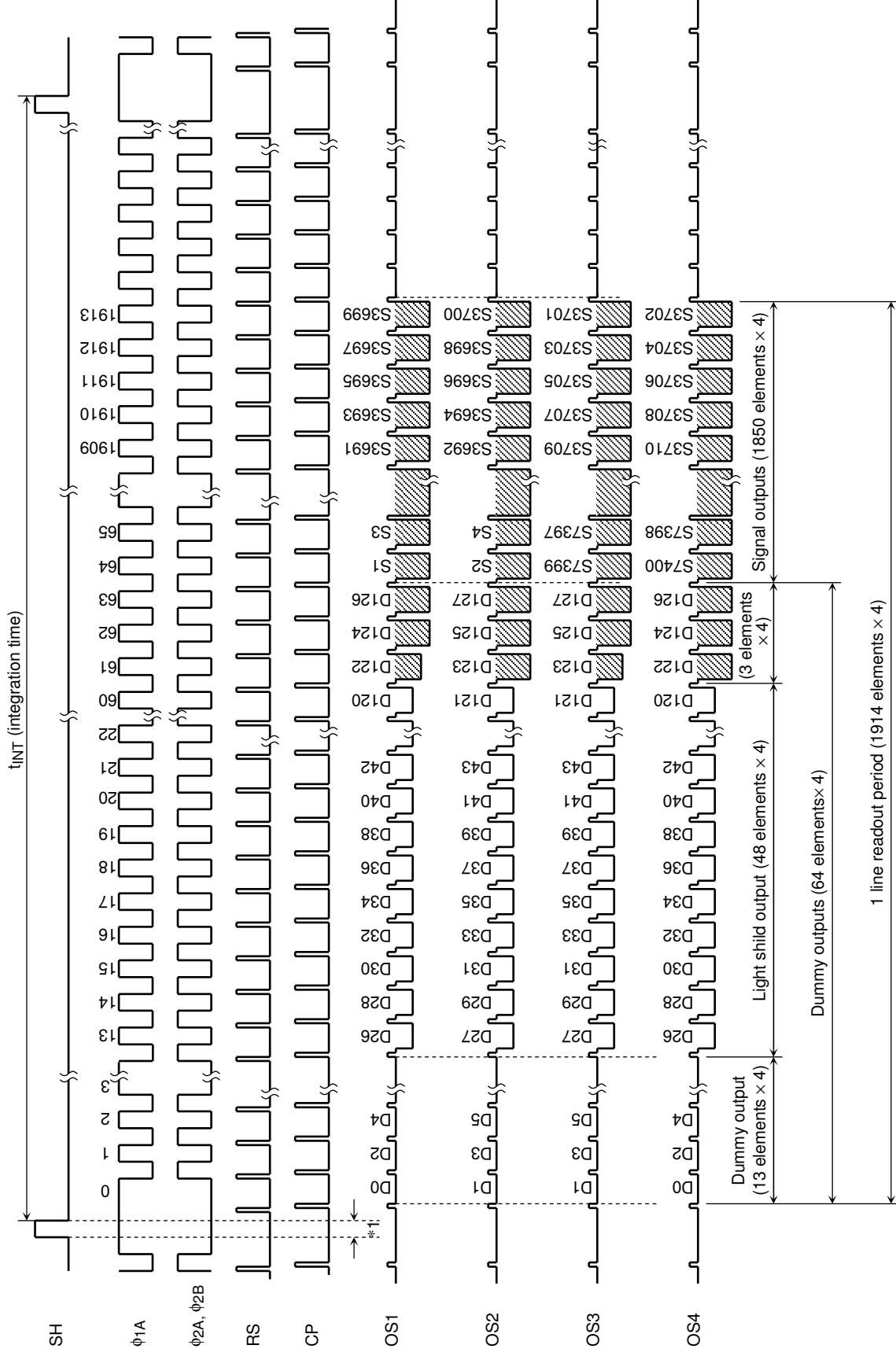

Timing Requirements

SH, ϕ_1 timing

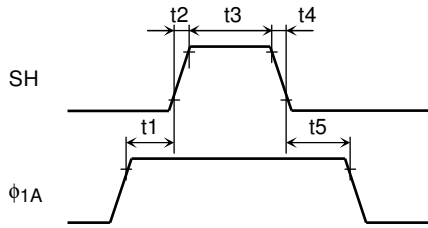

ϕ_2 , RS, CP, OS timing

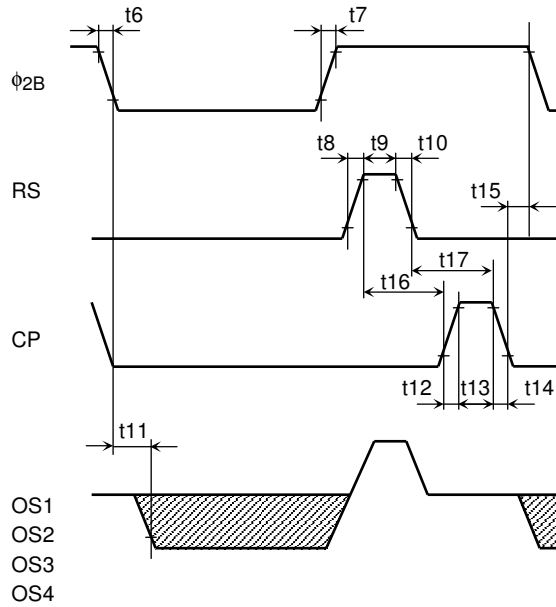

SH, RS, CP timing

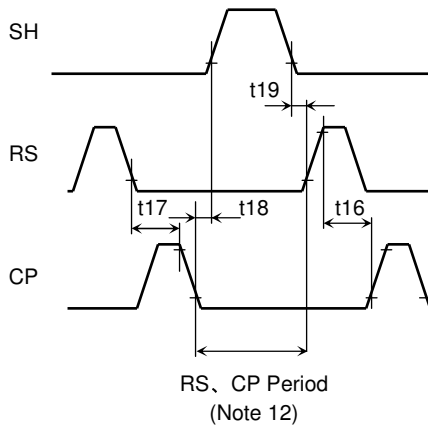

ϕ_1, ϕ_2 cross point

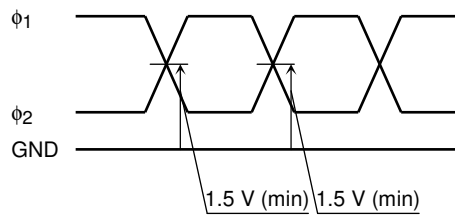

Note 12: Each RS and CP pins put to low level during this period.

Timing Requirements (cont.)

Characteristics	Symbol	Min	Typ. (Note13)	Max	Unit
Pulse timing of SH and ϕ 1A	t1, t5	200	500	—	ns
SH pulse rise time, fall time	t2, t4	0	50	—	ns
SH pulse width	t3	1000	1500	—	ns
ϕ 2B Pulse rise time, fall time	t6, t7	0	20	—	ns
RS pulse rise time, fall time	t8, t10	0	20	—	ns
RS pulse width	t9	10	100	—	ns
Video data delay time (Note 14)	t11	—	10	—	ns
CP pulse rise time, fall time	t12, t14	0	20	—	ns
CP pulse width	t13	10	200	—	ns
Pulse timing of ϕ 2B and CP	t15	0	50	—	ns
Pulse timing of RS and CP	t16	0	0	—	ns
	t17	10	100	—	
Pulse timing of SH and CP	t18	200	—	—	ns
Pulse timing of SH and RS	t19	200	—	—	ns

Note 13: Typ. is the case of $f_{RS} = 1.0$ MHz.

Note 14: Load Resistance is 100 k Ω .

Precautions for use of CCD image sensor

1. Static electricity

CCD image sensor is protected against static electricity, but inferior puncture mode device due to static electricity is sometimes detected. In handling the device, it is necessary to execute the following static electricity preventive measures, in order to prevent, the trouble rate increase of the manufacturing system due to static electricity.

- a. prevent the generation of static electricity due to friction by making the work with bare hands or by putting on cotton gloves and non-charging working clothes.
- b. Discharge the static electricity by providing earth plate or earth wire on the floor, door or stand of the work room.
- c. Ground the tools as soldering iron, radio cutting plier or pincette.

It is not necessarily required to execute all precaution items for static electricity.

It is all right to mitigate the precautions by confirming that the trouble rate within the prescribed range.

2. Window glass

As the dust and station on the glass window of the package will cause black flow on the picture, never fail to clean the glass surface before using. (Blow compressed vapor, and wipe of the dust, and dirt with soft cloth or paper slightly moistened with alcohol).

Fully take care for the handling of the device as the window glass will break or a strong friction is given to the window glass surface.

3. Incident Light

CCD image sensor has sensitivity in a wide zone of light wave length, but its characteristics will sometimes widely change when used with long wave length input light outside the visual light zone.

4. Lead Frame Forming

Since this package is not strong against mechanical stress, you should not reform the lead frame.

We recommend to use a IC-inserter when you assemble to PCB.

5. Soldering

Soldering by the solder flow method cannot be guaranteed because this method may have deleterious effects on prevention of window glass soiling and heat resistance.

Using a soldering iron, complete soldering within ten seconds for lead temperatures of up to 260°C, or within three seconds for lead temperatures of up to 350°C.

Package Dimensions

WDIP22-G-400-2.54D

Unit: mm

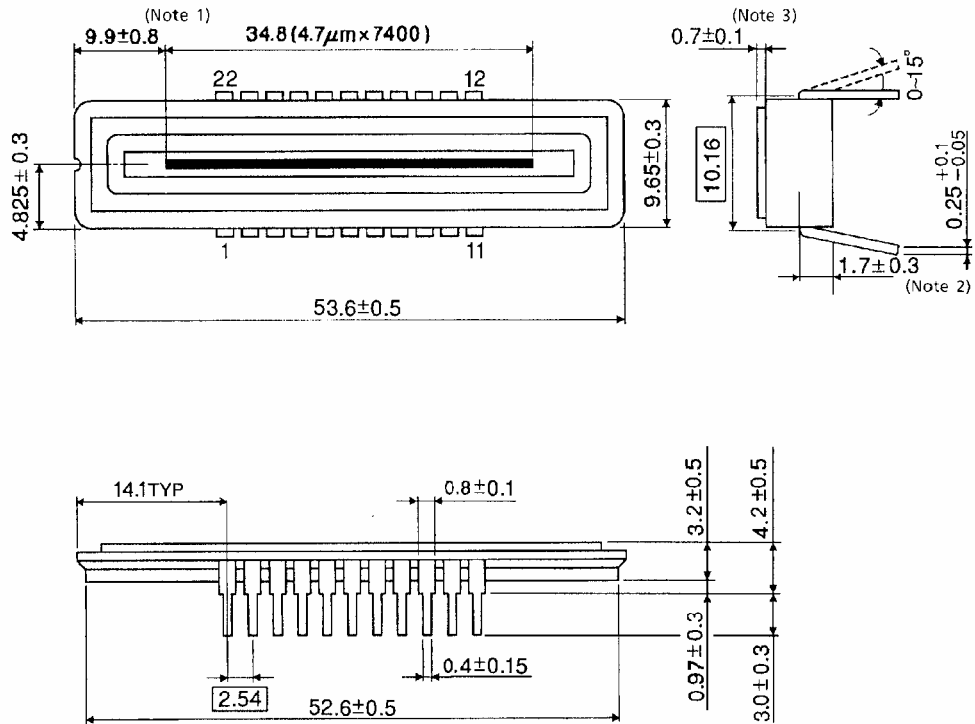

- (Note 1) : No. 1 SENSOR ELEMENT (S1) TO EDGE OF PACKAGE.
- (Note 2) : TOP OF CHIP TO BOTTOM OF PACKAGE.
- (Note 3) : GLASS THICKNES (n = 1.5)

Weight: 4.4 g (typ.)

About solderability, following conditions were confirmed

- Solderability

- (1) Use of Sn-63Pb solder Bath

- solder bath temperature = 230°C
 - dipping time = 5 seconds
 - the number of times = once
 - use of R-type flux

- (2) Use of Sn-3.0Ag-0.5Cu solder Bath

- solder bath temperature = 245°C
 - dipping time = 5 seconds
 - the number of times = once
 - use of R-type flux

RESTRICTIONS ON PRODUCT USE

030619EBA

- The information contained herein is subject to change without notice.
- The information contained herein is presented only as a guide for the applications of our products. No responsibility is assumed by TOSHIBA for any infringements of patents or other rights of the third parties which may result from its use. No license is granted by implication or otherwise under any patent or patent rights of TOSHIBA or others.
- TOSHIBA is continually working to improve the quality and reliability of its products. Nevertheless, semiconductor devices in general can malfunction or fail due to their inherent electrical sensitivity and vulnerability to physical stress. It is the responsibility of the buyer, when utilizing TOSHIBA products, to comply with the standards of safety in making a safe design for the entire system, and to avoid situations in which a malfunction or failure of such TOSHIBA products could cause loss of human life, bodily injury or damage to property.
In developing your designs, please ensure that TOSHIBA products are used within specified operating ranges as set forth in the most recent TOSHIBA products specifications. Also, please keep in mind the precautions and conditions set forth in the "Handling Guide for Semiconductor Devices," or "TOSHIBA Semiconductor Reliability Handbook" etc..
- The TOSHIBA products listed in this document are intended for usage in general electronics applications (computer, personal equipment, office equipment, measuring equipment, industrial robotics, domestic appliances, etc.). These TOSHIBA products are neither intended nor warranted for usage in equipment that requires extraordinarily high quality and/or reliability or a malfunction or failure of which may cause loss of human life or bodily injury ("Unintended Usage"). Unintended Usage include atomic energy control instruments, airplane or spaceship instruments, transportation instruments, traffic signal instruments, combustion control instruments, medical instruments, all types of safety devices, etc.. Unintended Usage of TOSHIBA products listed in this document shall be made at the customer's own risk.
- The products described in this document are subject to the foreign exchange and foreign trade laws.
- TOSHIBA products should not be embedded to the downstream products which are prohibited to be produced and sold, under any law and regulations.