

REV.	MODIFICATION.	DATE	DRN
01	PRODUCTION RELEASE	26/03/12	RA

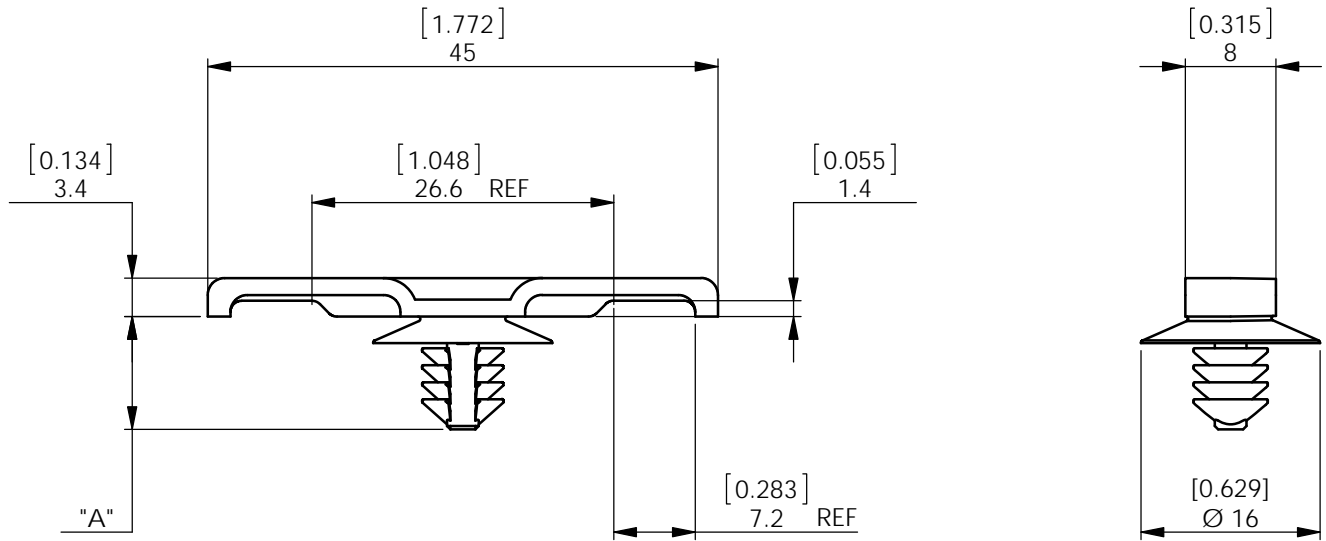

NOTE:
ALTERNATE UNITS FOR REFERENCE ONLY

PART No	"A"	HOLE Ø/ THREADED HOLE	MIN PANEL THICKNESS	MATERIAL	COLOR
TCHBH1-1-19	8.1[0.318]	4.8[0.188] / M5	0.8[0.031]	NYLON 66 UL94- V0 (RMS-019)	BLACK
TCHBH2-1-19	9.8[0.385]	6.4[0.251] / M8			
TCHBH1-1-UVB	8.1[0.318]	4.8[0.188] / M5		NYLON 66 UV STABILISED UL94- V2 (RMS-046)	
TCHBH2-1-UVB	9.8[0.385]	6.4[0.251] / M8			

INFORMATION CONTAINED IN THIS DOCUMENT IS CONFIDENTIAL TO RICHCO INTERNATIONAL Co. Ltd. AND MAY NOT BE DISCLOSED OR REPRODUCED IN WHOLE OR PART WITHOUT THEIR WRITTEN CONSENT.

RICHCO, INC.
WWW.RICHCO-INC.COM

ALL DIMENSIONS IN mm
GENERAL TOLERANCES ±0.25
UNLESS OTHERWISE STATED
1 DECIMAL PLACE ±0.25
2 DECIMAL PLACES ± 0.10
ANGULAR ±1°

THIRD ANGLE

MATERIAL: SEE TABLE COLOUR: SEE TABLE

DESCRIPTION: TAPE ON CABLE HOLDER PART No: SEE TABLE

DRG No: 012-042 PROJECT NUMBER: EU12-0012 SHEET SIZE: A4

DRN RA	DATE 28/03/12	CHKD TC	DATE 28/03/12	SCALE NTS	SHEET No. 1 OF 1
-----------	------------------	------------	------------------	--------------	---------------------