

TCP630

Reconfigurable FPGA

with 64 TTL I/O / 32 Differential I/O Lines

Version 1.0

User Manual

Issue 1.0.3

November 2010

TEWS TECHNOLOGIES GmbH

Am Bahnhof 7 25469 Halstenbek, Germany

Phone: +49 (0) 4101 4058 0 Fax: +49 (0) 4101 4058 19

e-mail: info@tews.com www.tews.com

TCP630-10

64 TTL I/O Lines, XC2S300E-6 Spartan-IIE FPGA

TCP630-11

32 Differential I/O Lines, XC2S300E-6 Spartan-IIE FPGA

TCP630-12

32 TTL I/O and 16 Differential I/O Lines, XC2S300E-6 Spartan-IIE FPGA

TCP630-20

64 TTL I/O Lines, XC2S300E-6 Spartan-IIE FPGA, J2 I/O

TCP630-21

32 Differential I/O Lines, XC2S300E-6 Spartan-IIE FPGA, J2 I/O

TCP630-22

32 TTL I/O and 16 Differential I/O Lines, XC2S300E-6 Spartan-IIE FPGA, J2 I/O

TCP630-30

64 TTL I/O Lines, XC2S600E-6 Spartan-IIE FPGA

TCP630-31

32 Differential I/O Lines, XC2S600E-6 Spartan-IIE FPGA

TCP630-32

32 TTL I/O and 16 Differential I/O Lines, XC2S600E-6 Spartan-IIE FPGA

TCP630-40

64 TTL I/O Lines, XC2S600E-6 Spartan-IIE FPGA, J2 I/O

TCP630-41

32 Differential I/O Lines, XC2S600E-6 Spartan-IIE FPGA, J2 I/O

TCP630-42

32 TTL I/O and 16 Differential I/O Lines, XC2S600E-6 Spartan-IIE FPGA, J2 I/O

This document contains information, which is proprietary to TEWS TECHNOLOGIES GmbH. Any reproduction without written permission is forbidden.

TEWS TECHNOLOGIES GmbH has made any effort to ensure that this manual is accurate and complete. However TEWS TECHNOLOGIES GmbH reserves the right to change the product described in this document at any time without notice.

TEWS TECHNOLOGIES GmbH is not liable for any damage arising out of the application or use of the device described herein.

Style Conventions

Hexadecimal characters are specified with prefix 0x, i.e. 0x029E (that means hexadecimal value 029E).

For signals on hardware products, an 'Active Low' is represented by the signal name with # following, i.e. IP_RESET#.

Access terms are described as:

W	Write Only
R	Read Only
R/W	Read/Write
R/C	Read/Clear
R/S	Read/Set

©2006-2010 by TEWS TECHNOLOGIES GmbH

All trademarks mentioned are property of their respective owners.

Issue	Description	Date
1.0	First Issue	November 2006
1.1	Corrected Configuration EEPROM	January 2007
1.0.2	New notation for HW Engineering Documentation Releases	February 2009
1.0.3	New module variants -3x & -4x	November 2010

Table of Contents

1	PRODUCT DESCRIPTION	8
2	TECHNICAL SPECIFICATION	9
3	LOCAL SPACE ADDRESSING	10
	3.1 PCI9030 Local Space Configuration	10
	3.2 FPGA Example Design Register Space	10
	3.2.1 Output Register 0 (OUT_REG0; 0x00).....	11
	3.2.2 Output Register 1 (OUT_REG1; 0x04).....	12
	3.2.3 Input Register 0 (IN_REG0; 0x08).....	13
	3.2.4 Input Register 1 (IN_REG1; 0x0C).....	14
	3.2.5 Output Enable Register 0 (OE_REG0; 0x10).....	15
	3.2.6 Output Enable Register 1 (OE_REG1; 0x14).....	16
	3.2.7 Interrupt Status Register (ISR; 0x18)	17
	3.2.8 Positive Edge Interrupt Enable Register (PIER; 0x1C)	17
	3.2.9 Negative Edge Interrupt Enable Register (NIER; 0x20).....	17
	3.2.10 RAM Address Map Register (RAMR; 0x24)	18
	3.2.11 RAM Space.....	18
4	PCI9030 TARGET CHIP	19
	4.1 PCI Configuration Registers (PCR)	19
	4.1.1 PCI9030 Header	19
	4.1.2 PCI Base Address Initialization	20
	4.2 Local Configuration Register (LCR)	21
	4.3 Configuration EEPROM	22
	4.4 Local Software Reset	23
	4.5 Local Bus	23
5	FPGA PROGRAMMING HINTS	24
	5.1 FPGA Design	24
	5.2 FPGA Pin Assignment	24
	5.2.1 Pin Assignment of Local Bus Control Signals	24
	5.2.2 Pin Assignment of Local Bus Data Signals	25
	5.2.3 Pin Assignment of Local Bus Address Signals.....	26
	5.2.4 Pin Assignment of Clock Signals.....	26
	5.2.5 Pin Assignment of FPGA Input Lines	27
	5.2.6 Pin Assignment of FPGA Output Lines	28
	5.2.7 Pin Assignment of FPGA Output Enable Lines	29
6	CONFIGURATION HINTS	30
	6.1 Big / Little Endian	30
	6.2 Clock Programming	32
	6.2.1 Default Clock Programming.....	32
7	INSTALLATION	34
	7.1 Pull Up Voltage	34
	7.2 I/O Interface	34
	7.2.1 TTL I/O Interface.....	34
	7.2.2 Differential I/O Interface.....	35
	7.3 Back I/O Configuration	36
	7.4 FPGA Debug Connector	37
	7.5 PIM Module Slot	38

8	PIN ASSIGNMENT – I/O CONNECTOR	39
8.1	PIM Slot Connectors	40
8.1.1	J10 Assignment	40
8.1.2	J14 Assignment TCP630-x0	41
8.1.3	J14 Assignment TCP630-x1	42
8.1.4	J14 Assignment TCP630-x2	43
8.2	Back I/O J2 Connector	44
8.2.1	Back I/O Assignment TCP630-20 / -40	44
8.2.2	Back I/O Assignment TCP630-21 / -41	45
8.2.3	Back I/O Assignment TCP630-22 / -42	46

Table of Figures

FIGURE 1-1 : BLOCK DIAGRAM.....	8
FIGURE 2-1 : TECHNICAL SPECIFICATION.....	9
FIGURE 3-1 : PCI9030 LOCAL SPACE CONFIGURATION	10
FIGURE 3-2 : FPGA EXAMPLE DESIGN REGISTER SPACE	10
FIGURE 3-3 : OUTPUT REGISTER 0 (OUT_REG0)	11
FIGURE 3-4 : OUTPUT REGISTER 1 (OUT_REG1)	12
FIGURE 3-5 : INPUT REGISTER 0 (IN_REG0).....	13
FIGURE 3-6 : INPUT REGISTER 1 (IN_REG1).....	14
FIGURE 3-7 : OUTPUT ENABLE REGISTER 0 (OE_REG0).....	15
FIGURE 3-8 : OUTPUT ENABLE REGISTER 1 (OE_REG1).....	16
FIGURE 3-9 : INTERRUPT STATUS REGISTER (ISR).....	17
FIGURE 3-10: POSITIVE EDGE INTERRUPT ENABLE REGISTER (PIER)	17
FIGURE 3-11: NEGATIVE EDGE INTERRUPT ENABLE REGISTER (NIER).....	17
FIGURE 3-12: ADDRESS MAP REGISTER (RAMR).....	18
FIGURE 4-1 : DEFAULT PCI9030 HEADER	19
FIGURE 4-2 : PCI9030 PCI BASE ADDRESS USAGE	20
FIGURE 4-3 : PCI9030 LOCAL CONFIGURATION REGISTER.....	21
FIGURE 4-4 : CONFIGURATION EEPROM TCP630	22
FIGURE 4-5 : DEFAULT VALUES OF SPACE 0 REGION DESCRIPTOR.....	23
FIGURE 5-1 : FPGA SIGNALS BLOCK DIAGRAM.....	24
FIGURE 5-2 : PIN ASSIGNMENT LOCAL BUS CONTROL SIGNALS	25
FIGURE 5-3 : PIN ASSIGNMENT LOCAL BUS DATA SIGNALS	25
FIGURE 5-4 : PIN ASSIGNMENT LOCAL BUS ADDRESS SIGNALS	26
FIGURE 5-5 : PIN ASSIGNMENT CLOCK INPUTS	26
FIGURE 5-6 : PIN ASSIGNMENT FPGA INPUT LINES.....	27
FIGURE 5-7 : PIN ASSIGNMENT FPGA OUTPUT LINES.....	28
FIGURE 5-8 : PIN ASSIGNMENT FPGA OUTPUT ENABLE LINES	29
FIGURE 6-1 : LOCAL BUS LITTLE/BIG ENDIAN.....	30
FIGURE 6-2 : DEFAULT VALUES OF CLOCK OUTPUTS (AT DELIVERY)	32
FIGURE 6-3 : DEFAULT REGISTER VALUES (AT DELIVERY).....	33
FIGURE 7-1 : PULL UP VOLTAGE JUMPER SETTING	34
FIGURE 7-2 : TTL I/O INTERFACE	35
FIGURE 7-3 : DIFFERENTIAL I/O INTERFACE.....	35
FIGURE 7-4 : JUMPER POSITIONS FOR GROUND OPTION.....	36
FIGURE 7-5 : JUMPER POSITIONS FOR BACK I/O OPTIONS.....	36
FIGURE 7-6 : DEBUG CONNECTOR (BOTTOM VIEW)	37
FIGURE 7-7 : DEBUG CONNECTOR PINOUT	37
FIGURE 7-8 : A PIM MODULE.....	38
FIGURE 8-1 : CONNECTOR POSITIONS.....	39
FIGURE 8-2 : PIN ASSIGNMENT J10 CONNECTOR.....	40

FIGURE 8-3 : PIN ASSIGNMENT J14 CONNECTOR TCP630-X0.....	41
FIGURE 8-4 : PIN ASSIGNMENT J14 CONNECTOR TCP630-X1.....	42
FIGURE 8-5 : PIN ASSIGNMENT J14 CONNECTOR TCP630-X2.....	43
FIGURE 8-6 : PIN ASSIGNMENT J2 I/O CONNECTOR TCP630-20 / -40	44
FIGURE 8-7 : PIN ASSIGNMENT J2 I/O CONNECTOR TCP630-21 / -41	45
FIGURE 8-8 : PIN ASSIGNMENT J2 I/O CONNECTOR TCP630-22 / -42	46

1 Product Description

The TCP630 is a standard 3U 32 bit CompactPCI module providing a user configurable FPGA with 300,000 or 600,000 system gates. All local signals from the PCI controller are routed to the FPGA.

The TCP630 provides 64 ESD-protected TTL lines, 32 differential I/O lines using EIA 422 / EIA 485 compatible, ESD-protected line transceivers or 32 TTL and 16 differential I/Os. All lines are individually programmable as input, output or tri-state. The receivers are always enabled, which allows determining the state of each I/O line at any time. This can be used as read back function for lines configured as outputs. Each TTL I/O line has a pull-up resistor. The pull-up voltage is selectable to be either +3.3V or +5V. The differential I/O lines are terminated by 120Ω resistors.

For flexible front I/O solutions the TCP630 provides a PIM Module slot, allowing active and passive signal conditioning. With the TPIM003 all I/O signals are provided on a HD68 connector. An option also offers in parallel rear I/O via the J2 connector.

The FPGA is configured by a serial flash. The flash device is in-system programmable via driver software over the PCI bus. An in-circuit debugging option is available via an optionally mountable JTAG header for readback and real-time debugging of the FPGA design (using Xilinx "ChipScope").

A programmable clock generator supplies up to six different clock frequencies between 200 kHz and 166 MHz. All outputs are available at the FPGA, one clock source is in addition used as the local clock signal for the PCI controller. The clock generator settings are stored in an EEPROM and can be changed by the driver software through PCI9030 GPIO pins.

The configuration EEPROM of the PCI controller can also be modified by the driver software, to adapt address spaces etc. User applications can be developed using the design software ISE WebPACK which can be downloaded free of charge from www.xilinx.com.

For First Time Users the Engineering Documentation is recommended, it includes schematics, data sheets of the components and well documented sample VHDL source code.

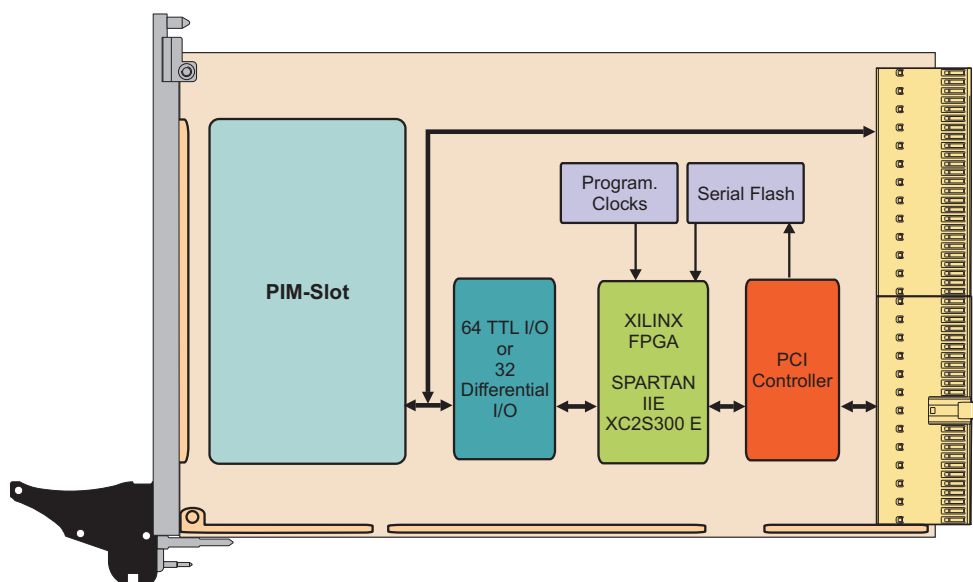

Figure 1-1 : Block Diagram

2 Technical Specification

PMC Interface	
Mechanical Interface	Standard 3U 32 Bit CompactPCI module conforming to PICMG 2.0 R3.0
Electrical Interface	PCI Rev. 2.2 compliant 33 MHz / 32 bit PCI 3.3V and 5V PCI Signaling Voltage
On Board Devices	
PCI Target Chip	PCI9030 (PLX Technology)
Local Control Logic	TPMC630-1x / -2x: FPGA Spartan-IIIE XC2S300E-6 FG456 I (Xilinx) TPMC630-3x / -4x: FPGA Spartan-IIIE XC2S600E-6 FG456 I (Xilinx)
Line Transceivers	74LVT126 (TTL I/O, TTL signaling voltage level with maximum current: +/-32 mA) MAX3078E (Differential I/O, EIA-422/-485 signaling level)
I/O Interface	
Number of Channels	64 TTL I/O (TCP630-10, -20, -30, 40), 32 differential I/O (TCP630-11, -21, -31, -41) or 32 TTL I/O and 16 differential I/O (TCP630-12, -22, -32, -42)
I/O Connectors	The TCP630 provides a PIM-slot instead of a front I/O connector TCP630-2x / -4x: additional 110 pol. CompactPCI back I/O (J2)
Physical Data	
Power Requirements	Without PIM & with Example Design: TCP630-x0: 160 mA typical (no load) @ +3.3V DC TCP630-x1: 110 mA typical (no load) @ +3.3V DC TCP630-x2: 120 mA typical (no load) @ +3.3V DC TCP630-x0: 10 mA typical @ +5V DC (when used as pull up voltage) TCP630-x1: +5V DC not used TCP630-x2: 10 mA typical @ +5V DC (when used as pull up voltage)
Temperature Range	Operating -40°C to +85°C Storage -40°C to +85°C
MTBF	TCP630-10, -30: 381 000 h TCP630-11, -31: 522 000 h TCP630-12, -32: 439 000 h TCP630-20, -40: 359 000 h TCP630-21, -41: 482 000 h TCP630-22, -42: 410 000 h
Humidity	5 – 95 % non-condensing
Weight	124 g

Figure 2-1 : Technical Specification

3 Local Space Addressing

3.1 PCI9030 Local Space Configuration

The local on board addressable regions are accessed from the PCI side by using the PCI9030 local spaces.

PCI9030 Local Space	PCI9030 PCI Base Address (Offset in PCI Configuration Space)	PCI Space Mapping	Size (Byte)	Port Width (Bit)	Endian Mode	Description
0	2 (0x18)	MEM	16 M	32	BIG	FPGA Example Design Register Space
1	3 (0x1C)	-	-	-	-	Not Used
2	4 (0x20)	-	-	-	-	Not Used
3	5 (0x24)	-	-	-	-	Not Used

Figure 3-1 : PCI9030 Local Space Configuration

3.2 FPGA Example Design Register Space

The TCP630 is delivered with a FPGA example design in the configuration memory.

PCI Base Address: PCI9030 PCI Base Address 2 (Offset 0x18 in PCI Configuration Space).

Offset to PCI Base Address 2	Register Name	Size (Bit)
0x00	Output Register 0 (OUT_REG0)	32
0x04	Output Register 1 (OUT_REG1)	32
0x08	Input Register 0 (IN_REG0)	32
0x0C	Input Register 1 (IN_REG1)	32
0x10	Output Enable Register 0 (OE_REG0)	32
0x14	Output Enable Register 1 (OE_REG1)	32
0x18	Interrupt Status Register (ISR)	32
0x1C	Positive Edge Interrupt Enable Register (PIER)	32
0x20	Negative Edge Interrupt Enable Register (NIER)	32
0x24	RAM Address Map Register (RAMR)	32
0x28 .. 0xFFFFF	256 x 32 bit RAM Space	32

Figure 3-2 : FPGA Example Design Register Space

3.2.1 Output Register 0 (OUT_REG0; 0x00)

Bit	Symbol	Description	Access	Reset Value
31	OUT_REG_BIT_31	Output Port Bit 31-0 Data (see notes below)	R/W	0
30	OUT_REG_BIT_30			
29	OUT_REG_BIT_29			
28	OUT_REG_BIT_28			
27	OUT_REG_BIT_27			
26	OUT_REG_BIT_26			
25	OUT_REG_BIT_25			
24	OUT_REG_BIT_24			
23	OUT_REG_BIT_23			
22	OUT_REG_BIT_22			
21	OUT_REG_BIT_21			
20	OUT_REG_BIT_20			
19	OUT_REG_BIT_19			
18	OUT_REG_BIT_18			
17	OUT_REG_BIT_17			
16	OUT_REG_BIT_16			
15	OUT_REG_BIT_15			
14	OUT_REG_BIT_14			
13	OUT_REG_BIT_13			
12	OUT_REG_BIT_12			
11	OUT_REG_BIT_11			
10	OUT_REG_BIT_10			
9	OUT_REG_BIT_9			
8	OUT_REG_BIT_8			
7	OUT_REG_BIT_7			
6	OUT_REG_BIT_6			
5	OUT_REG_BIT_5			
4	OUT_REG_BIT_4			
3	OUT_REG_BIT_3			
2	OUT_REG_BIT_2			
1	OUT_REG_BIT_1			
0	OUT_REG_BIT_0			

Figure 3-3 : Output Register 0 (OUT_REG0)

TCP630-10: Output Port Bits 0 - 31 are written to IO_0 - IO_31 (TTL)
TCP630-11: Output Port Bits 0 - 31 are written to IO_0A/B - IO_31A/B (Differential)
TCP630-12: Output Port Bits 0 - 15 are written to IO_0A/B - IO_15A/B (Differential)
Output Port Bits 16 - 31 are not used

3.2.2 Output Register 1 (OUT_REG1; 0x04)

Bit	Symbol	Description	Access	Reset Value
63	OUT_REG_BIT_63			
62	OUT_REG_BIT_62			
61	OUT_REG_BIT_61			
60	OUT_REG_BIT_60			
59	OUT_REG_BIT_59			
58	OUT_REG_BIT_58			
57	OUT_REG_BIT_57			
56	OUT_REG_BIT_56			
55	OUT_REG_BIT_55			
54	OUT_REG_BIT_54			
53	OUT_REG_BIT_53			
52	OUT_REG_BIT_52			
51	OUT_REG_BIT_51			
50	OUT_REG_BIT_50			
49	OUT_REG_BIT_49			
48	OUT_REG_BIT_48	Output Port Bit 63-32 Data (see notes below)	R/W	0
47	OUT_REG_BIT_47			
46	OUT_REG_BIT_46			
45	OUT_REG_BIT_45			
44	OUT_REG_BIT_44			
43	OUT_REG_BIT_43			
42	OUT_REG_BIT_42			
41	OUT_REG_BIT_41			
40	OUT_REG_BIT_40			
39	OUT_REG_BIT_39			
38	OUT_REG_BIT_38			
37	OUT_REG_BIT_37			
36	OUT_REG_BIT_36			
35	OUT_REG_BIT_35			
34	OUT_REG_BIT_34			
33	OUT_REG_BIT_33			
32	OUT_REG_BIT_32			

Figure 3-4 : Output Register 1 (OUT_REG1)

TCP630-10: Output Port Bits 32 - 63 are written to IO_32 - IO_63 (TTL)
TCP630-11: Output Port Bits 32 - 63 are not used
TCP630-12: Output Port Bits 32 - 63 are written to IO_32 - IO_63 (TTL)

3.2.3 Input Register 0 (IN_REG0; 0x08)

Bit	Symbol	Description	Access	Reset Value
31	IN_REG_BIT_31	Input Port Bit 31-0 Data Read directly from the I/O lines 31 to 0. (see notes below)	R	-
30	IN_REG_BIT_30			
29	IN_REG_BIT_29			
28	IN_REG_BIT_28			
27	IN_REG_BIT_27			
26	IN_REG_BIT_26			
25	IN_REG_BIT_25			
24	IN_REG_BIT_24			
23	IN_REG_BIT_23			
22	IN_REG_BIT_22			
21	IN_REG_BIT_21			
20	IN_REG_BIT_20			
19	IN_REG_BIT_19			
18	IN_REG_BIT_18			
17	IN_REG_BIT_17			
16	IN_REG_BIT_16			
15	IN_REG_BIT_15			
14	IN_REG_BIT_14			
13	IN_REG_BIT_13			
12	IN_REG_BIT_12			
11	IN_REG_BIT_11			
10	IN_REG_BIT_10			
9	IN_REG_BIT_9			
8	IN_REG_BIT_8			
7	IN_REG_BIT_7			
6	IN_REG_BIT_6			
5	IN_REG_BIT_5			
4	IN_REG_BIT_4			
3	IN_REG_BIT_3			
2	IN_REG_BIT_2			
1	IN_REG_BIT_1			
0	IN_REG_BIT_0			

Figure 3-5 : Input Register 0 (IN_REG0)

TCP630-10: Input Port Bits 0 - 31 are read from IO_0 - IO_31 (TTL)
TCP630-11: Input Port Bits 0 - 31 are read from IO_0A/B - IO_31A/B (Differential)
TCP630-12: Input Port Bits 0 - 15 are read from IO_0A/B - IO_15A/B (Differential)
Input Port Bits 16 - 31 are not used

3.2.4 Input Register 1 (IN_REG1; 0x0C)

Bit	Symbol	Description	Access	Reset Value
63	IN_REG_BIT_63			
62	IN_REG_BIT_62			
61	IN_REG_BIT_61			
60	IN_REG_BIT_60			
59	IN_REG_BIT_59			
58	IN_REG_BIT_58			
57	IN_REG_BIT_57			
56	IN_REG_BIT_56			
55	IN_REG_BIT_55			
54	IN_REG_BIT_54			
53	IN_REG_BIT_53			
52	IN_REG_BIT_52			
51	IN_REG_BIT_51			
50	IN_REG_BIT_50			
49	IN_REG_BIT_49			
48	IN_REG_BIT_48	Input Port Bit 63-32 Data Read directly from the I/O lines 63 to 32 (see notes below)	R	-
47	IN_REG_BIT_47			
46	IN_REG_BIT_46			
45	IN_REG_BIT_45			
44	IN_REG_BIT_44			
43	IN_REG_BIT_43			
42	IN_REG_BIT_42			
41	IN_REG_BIT_41			
40	IN_REG_BIT_40			
39	IN_REG_BIT_39			
38	IN_REG_BIT_38			
37	IN_REG_BIT_37			
36	IN_REG_BIT_36			
35	IN_REG_BIT_35			
34	IN_REG_BIT_34			
33	IN_REG_BIT_33			
32	IN_REG_BIT_32			

Figure 3-6 : Input Register 1 (IN_REG1)

TCP630-10: Input Port Bits 32 - 63 are read from IO_32 - IO_63 (TTL)
TCP630-11: Input Port Bits 32 - 63 are not used
TCP630-12: Input Port Bits 32 - 63 are read from IO_32 - IO_63 (TTL)

3.2.5 Output Enable Register 0 (OE_REG0; 0x10)

Bit	Symbol	Description	Access	Reset Value
31	OE_REG_BIT_31			
30	OE_REG_BIT_30			
29	OE_REG_BIT_29			
28	OE_REG_BIT_28			
27	OE_REG_BIT_27			
26	OE_REG_BIT_26			
25	OE_REG_BIT_25			
24	OE_REG_BIT_24			
23	OE_REG_BIT_23			
22	OE_REG_BIT_22			
21	OE_REG_BIT_21			
20	OE_REG_BIT_20			
19	OE_REG_BIT_19			
18	OE_REG_BIT_18			
17	OE_REG_BIT_17	Output Enable Bit 31-0		
16	OE_REG_BIT_16	(see notes below)		
15	OE_REG_BIT_15	0: disables the output transceiver	R/W	0
14	OE_REG_BIT_14	1: enables the output transceiver		
13	OE_REG_BIT_13			
12	OE_REG_BIT_12			
11	OE_REG_BIT_11			
10	OE_REG_BIT_10			
9	OE_REG_BIT_9			
8	OE_REG_BIT_8			
7	OE_REG_BIT_7			
6	OE_REG_BIT_6			
5	OE_REG_BIT_5			
4	OE_REG_BIT_4			
3	OE_REG_BIT_3			
2	OE_REG_BIT_2			
1	OE_REG_BIT_1			
0	OE_REG_BIT_0			

Figure 3-7 : Output Enable Register 0 (OE_REG0)

TCP630-10: Output Enable Bits 0 - 31 control Output 0 – Output 31 (TTL)
TCP630-11: Output Enable Bits 0 - 31 control Output 0 – Output 31 (Differential)
TCP630-12: Output Enable Bits 0 - 15 control Output 0 – Output 15 (Differential)
Output Enable Bits 16 - 31 are not used

3.2.6 Output Enable Register 1 (OE_REG1; 0x14)

Bit	Symbol	Description	Access	Reset Value
63	OE_REG_BIT_63			
62	OE_REG_BIT_62			
61	OE_REG_BIT_61			
60	OE_REG_BIT_60			
59	OE_REG_BIT_59			
58	OE_REG_BIT_58			
57	OE_REG_BIT_57			
56	OE_REG_BIT_56			
55	OE_REG_BIT_55			
54	OE_REG_BIT_54			
53	OE_REG_BIT_53			
52	OE_REG_BIT_52			
51	OE_REG_BIT_51			
50	OE_REG_BIT_50			
49	OE_REG_BIT_49	Output Enable Bit 63-32		
48	OE_REG_BIT_48	(see notes below)		
47	OE_REG_BIT_47	0: disables the output transceiver	R/W	0
46	OE_REG_BIT_46	1: enables the output transceiver		
45	OE_REG_BIT_45			
44	OE_REG_BIT_44			
43	OE_REG_BIT_43			
42	OE_REG_BIT_42			
41	OE_REG_BIT_41			
40	OE_REG_BIT_40			
39	OE_REG_BIT_39			
38	OE_REG_BIT_38			
37	OE_REG_BIT_37			
36	OE_REG_BIT_36			
35	OE_REG_BIT_35			
34	OE_REG_BIT_34			
33	OE_REG_BIT_33			
32	OE_REG_BIT_32			

Figure 3-8 : Output Enable Register 1 (OE_REG1)

TCP630-10: Output Enable Bits 32 - 63 control Output 32 – Output 63 (TTL)
TCP630-11: Output Enable Bits 32 - 63 are not used
TCP630-12: Output Enable Bits 32 - 63 control Output 32 – Output 63 (TTL)

3.2.7 Interrupt Status Register (ISR; 0x18)

Bit	Symbol	Description	Access	Reset Value
31: 8	-	Reserved (0 for reads)	-	0
7	INT_7	Line 7-0 Interrupt Request Status The Interrupt Status Register signals the lines on which an interrupt event occurred. The example design supports interrupts only for line 0 to 7. 0 = no active interrupt request 1 = active interrupt request	R/W	0
6	INT_6			
5	INT_5			
4	INT_4			
3	INT_3			
2	INT_2			
1	INT_1			
0	INT_0			

Figure 3-9 : Interrupt Status Register (ISR)

3.2.8 Positive Edge Interrupt Enable Register (PIER; 0x1C)

Bit	Symbol	Description	Access	Reset Value
31:8	-	Reserved (0 for reads)	-	0
7	PIE_7	Line 7-0 Rising Edge Interrupt Enable 0 = disabled 1 = enabled	R/W	0
6	PIE_6			
5	PIE_5			
4	PIE_4			
3	PIE_3			
2	PIE_2			
1	PIE_1			
0	PIE_0			

Figure 3-10: Positive Edge Interrupt Enable Register (PIER)

3.2.9 Negative Edge Interrupt Enable Register (NIER; 0x20)

Bit	Symbol	Description	Access	Reset Value
31:8	-	Reserved (0 for reads)	-	0
7	NIE_7	Line 7-0 Falling Edge Interrupt Enable 0 = disabled 1 = enabled	R/W	0
6	NIE_6			
5	NIE_5			
4	NIE_4			
3	NIE_3			
2	NIE_2			
1	NIE_1			
0	NIE_0			

Figure 3-11: Negative Edge Interrupt Enable Register (NIER)

3.2.10 RAM Address Map Register (RAMR; 0x24)

The RAM Address Map Register determines at which address the 256 x 32 bit RAM space begins, within the 16 MByte address space. If RAMR is set to 0x0, the addresses from 0x0 to 0x24 are occupied by the registers. Only 32 bit accesses are possible.

Bit	Symbol	Description	Access	Reset Value
31:24	-	Reserved (0 for reads)	-	0
23	RAM_ADD_MAP_BIT_23	Address Map Bit 23 - 10	R/W	0
22	RAM_ADD_MAP_BIT_22			0
21	RAM_ADD_MAP_BIT_21			0
20	RAM_ADD_MAP_BIT_20			0
19	RAM_ADD_MAP_BIT_19			0
18	RAM_ADD_MAP_BIT_18			0
17	RAM_ADD_MAP_BIT_17			0
16	RAM_ADD_MAP_BIT_16			0
15	RAM_ADD_MAP_BIT_15			0
14	RAM_ADD_MAP_BIT_14			0
13	RAM_ADD_MAP_BIT_13			0
12	RAM_ADD_MAP_BIT_12	0		
11	RAM_ADD_MAP_BIT_11	0		
10	RAM_ADD_MAP_BIT_10	1		
9:0	-	Reserved (0 for reads)	-	0

Figure 3-12: Address Map Register (RAMR)

3.2.11 RAM Space

There is a 256 x 32 bit RAM space available; it is accessed if the address bits match to the content of the RAM Address Map Register (see description of RAMR). Only 32 bit accesses are possible.

4 PCI9030 Target Chip

4.1 PCI Configuration Registers (PCR)

4.1.1 PCI9030 Header

PCI CFG Register Address	Write '0' to all unused (Reserved) bits							PCI writeable	Initial Values (Hex Values)	
	31	24	23	16	15	8	7			0
0x00	Device ID				Vendor ID				N	2276 1498
0x04	Status				Command				Y	0280 0000
0x08	Class Code					Revision ID			N	118000 00
0x0C	BIST	Header Type		PCI Latency Timer		Cache Line Size		Y[7:0]	00 00 00 00	
0x10	PCI Base Address 0 for MEM Mapped Config. Registers								Y	FFFFFFF80
0x14	PCI Base Address 1 for I/O Mapped Config. Registers								Y	FFFFFFF81
0x18	PCI Base Address 2 for Local Address Space 0								Y	FF000000
0x1C	PCI Base Address 3 for Local Address Space 1								Y	00000000
0x20	PCI Base Address 4 for Local Address Space 2								Y	00000000
0x24	PCI Base Address 5 for Local Address Space 3								Y	00000000
0x28	PCI CardBus Information Structure Pointer								N	00000000
0x2C	Subsystem ID				Subsystem Vendor ID				N	s.b. 1498
0x30	PCI Base Address for Local Expansion ROM								Y	00000000
0x34	Reserved					New Cap. Ptr.			N	000000 40
0x38	Reserved								N	00000000
0x3C	Max_Lat	Min_Gnt		Interrupt Pin		Interrupt Line		Y[7:0]	00 00 01 00	
0x40	PM Cap.			PM Nxt Cap.		PM Cap. ID			N	4801 00 01
0x44	PM Data		PM CSR EXT		PM CSR				Y	00 00 0000
0x48	Reserved		HS CSR		HS Nxt Cap.		HS Cap. ID		Y[23:16]	00 00 00 06
0x4C	VPD Address			VPD Nxt Cap.		VPD Cap. ID			Y[31:16]	0000 00 03
0x50	VPD Data								Y	00000000

Figure 4-1 : Default PCI9030 Header

Subsystem ID Value (Offset 0x2E):	TCP630-10	0x200A	TCP630-30	0x201E
	TCP630-11	0x200B	TCP630-31	0x201F
	TCP630-12	0x200C	TCP630-32	0x2020
	TCP630-20	0x2014	TCP630-40	0x2028
	TCP630-21	0x2015	TCP630-41	0x2029
	TCP630-22	0x2016	TCP630-42	0x202A

4.1.2 PCI Base Address Initialization

PCI Base Address Initialization is scope of the PCI host software.

PCI9030 PCI Base Address Initialization:

1. Write 0xFFFF_FFFF to the PCI9030 PCI Base Address Register.
2. Read back the PCI9030 PCI Base Address Register.
3. For PCI Base Address Registers 0:5, check bit 0 for PCI Address Space.
 - Bit 0 = '0' requires PCI Memory Space mapping
 - Bit 0 = '1' requires PCI I/O Space mapping

For the PCI Expansion ROM Base Address Register, check bit 0 for usage.

 - Bit 0 = '0': Expansion ROM not used
 - Bit 0 = '1': Expansion ROM used
4. For PCI I/O Space mapping, starting at bit location 2, the first bit set determines the size of the required PCI I/O Space size.

For PCI Memory Space mapping, starting at bit location 4, the first bit set to '1' determines the size of the required PCI Memory Space size.

For PCI Expansion ROM mapping, starting at bit location 11, the first bit set to '1' determines the required PCI Expansion ROM size.

For example, if bit 5 of a PCI Base Address Register is detected as the first bit set to '1', the PCI9030 is requesting a 32 byte space (address bits 4:0 are not part of base address decoding).
5. Determine the base address and write the base address to the PCI9030 PCI Base Address Register. For PCI Memory Space mapping the mapped address region must comply with the definition of bits 3:1 of the PCI9030 PCI Base Address Register.

After programming the PCI9030 PCI Base Address Registers, the software must enable the PCI9030 for PCI I/O and/or PCI Memory Space access in the PCI9030 PCI Command Register (Offset 0x04). To enable PCI I/O Space access to the PCI9030, set bit 0 to '1'. To enable PCI Memory Space access to the PCI9030, set bit 1 to '1'.

Offset in Config.	Description	Usage
0x10	PCI9030 LCR's MEM	Used
0x14	PCI9030 LCR's I/O	Used
0x18	PCI9030 Local Space 0	Used
0x1C	PCI9030 Local Space 1	Not used
0x30	Expansion ROM	Not used

Figure 4-2 : PCI9030 PCI Base Address Usage

4.2 Local Configuration Register (LCR)

After reset, the PCI9030 Local Configuration Registers are loaded from the on board serial configuration EEPROM.

The PCI base address for the PCI9030 Local Configuration Registers is PCI9030 PCI Base Address 0 (PCI Memory Space) (Offset 0x10 in the PCI9030 PCI Configuration Register Space) or PCI9030 PCI Base Address 1 (PCI I/O Space) (Offset 0x14 in the PCI9030 PCI Configuration Register Space).

Please be very careful when changing any hardware dependent bit settings in the PCI9030 Local Configuration Registers.

Offset from PCI Base Address	Register	Default Value	Description
0x00	Local Address Space 0 Range	0x0F00_0000	Defines size of space
0x04	Local Address Space 1 Range	0x0000_0000	
0x08	Local Address Space 2 Range	0x0000_0000	
0x0C	Local Address Space 3 Range	0x0000_0000	
0x10	Local Exp. ROM Range	0x0000_0000	
0x14	Local Re-map Register Space 0	0x0000_0001	Defines local address of space
0x18	Local Re-map Register Space 1	0x0000_0000	
0x1C	Local Re-map Register Space 2	0x0000_0000	
0x20	Local Re-map Register Space 3	0x0000_0000	
0x24	Local Re-map Register ROM	0x0000_0000	
0x28	Local Address Space 0 Descriptor	0x1581_20A0	Defines properties of space
0x2C	Local Address Space 1 Descriptor	0x0000_0000	
0x30	Local Address Space 2 Descriptor	0x0000_0000	
0x34	Local Address Space 3 Descriptor	0x0000_0000	
0x38	Local Exp. ROM Descriptor	0x0000_0000	
0x3C	Chip Select 0 Base Address	0x0080_0001	Defines range for Chip Select
0x40	Chip Select 1 Base Address	0x0000_0002	
0x44	Chip Select 2 Base Address	0x0000_0002	
0x48	Chip Select 3 Base Address	0x0000_0002	
0x4C	Interrupt Control/Status	0x0041	
0x4E	EEPROM Write Protect Boundary	0x0030	
0x50	Miscellaneous Control Register	0x0078_0000	
0x54	General Purpose I/O Control	0x0000_0240	
0x70	Hidden1 Power Management data select	0x0000_0000	
0x74	Hidden 2 Power Management data scale	0x0000_0000	

Figure 4-3 : PCI9030 Local Configuration Register

4.3 Configuration EEPROM

After power-on or PCI reset, the PCI9030 loads initial configuration register data from the on board configuration EEPROM.

The configuration EEPROM contains the following configuration data:

- Address 0x00 to 0x27 : PCI9030 PCI Configuration Register Values
- Address 0x28 to 0x87 : PCI9030 Local Configuration Register Values
- Address 0x88 to 0xFF : Reserved

See the PCI9030 Manual for more information.

The following table shows the default content of the EEPROM. **Highlighted** values can be modified by the driver software.

Address	Offset							
	0x00	0x02	0x04	0x06	0x08	0x0A	0x0C	0x0E
0x00	0x2276	0x1498	0x0280	0x0000	0x1180	0x0000	s.b.	0x1498
0x10	0x0000	0x0040	0x0000	0x0100	0x4801	0x0001	0x0000	0x0000
0x20	0x0000	0x0006	0x0000	0x0003	0x0F00	0x0000	0x0000	0x0000
0x30	0x0000	0x0000	0x0000	0x0000	0x0000	0x0000	0x0000	0x0001
0x40	0x0000	0x0000	0x0000	0x0000	0x0000	0x0000	0x0000	0x0000
0x50	0x1581	0x20A0	0x0000	0x0000	0x0000	0x0000	0x0000	0x0000
0x60	0x0000	0x0000	0x0080	0x0001	0x0000	0x0002	0x0000	0x0002
0x70	0x0000	0x0002	0x0030	0x0041	0x0078	0x0000	0x0000	0x0240
0x80	0x0000	0x0000	0x0000	0x0000	0xFFFF	0xFFFF	0xFFFF	0xFFFF
0x90	0xFFFF	0xFFFF	0xFFFF	0xFFFF	0xFFFF	0xFFFF	0xFFFF	0xFFFF
0xA0	0xFFFF	0xFFFF	0xFFFF	0xFFFF	0xFFFF	0xFFFF	0xFFFF	0xFFFF
0xB0	0xFFFF	0xFFFF	0xFFFF	0xFFFF	0xFFFF	0xFFFF	0xFFFF	0xFFFF
0xC0	0xFFFF	0xFFFF	0xFFFF	0xFFFF	0xFFFF	0xFFFF	0xFFFF	0xFFFF
0xD0	0xFFFF	0xFFFF	0xFFFF	0xFFFF	0xFFFF	0xFFFF	0xFFFF	0xFFFF
0xE0	0xFFFF	0xFFFF	0xFFFF	0xFFFF	0xFFFF	0xFFFF	0xFFFF	0xFFFF
0xF0	0xFFFF	0xFFFF	0xFFFF	0xFFFF	0xFFFF	0xFFFF	0xFFFF	0xFFFF

Figure 4-4 : Configuration EEPROM TCP630

Subsystem ID Value (Offset 0x2E):	TCP630-10	0x200A	TCP630-30	0x201E
	TCP630-11	0x200B	TCP630-31	0x201F
	TCP630-12	0x200C	TCP630-32	0x2020
	TCP630-20	0x2014	TCP630-40	0x2028
	TCP630-21	0x2015	TCP630-41	0x2029
	TCP630-22	0x2016	TCP630-42	0x202A

4.4 Local Software Reset

The PCI9030 Local Reset Output LRESETo# is used to reset the on board local logic.

The PCI9030 local reset is active during PCI reset or if the PCI Adapter Software Reset bit is set in the PCI9030 local configuration register CNTRL (offset 0x50).

CNTRL[30] PCI Adapter Software Reset:

Value of '1' resets the PCI9030 and issues a reset to the Local Bus (LRESETo# asserted). The PCI9030 remains in this reset condition until the PCI Host clears this bit. The contents of the PCI9030 PCI and Local Configuration Registers are not reset. The PCI9030 PCI Interface is not reset.

4.5 Local Bus

The PCI9030 Local Bus is a 32 bit non-multiplexed bus. Many parameters of the local interface can be configured, such as wait states, delays, etc. (see PCI9030 Data Book).

The default values of the Local Address Space 0 Bus Region Descriptor (LAS0BRD; 0x28) for the example design are:

Bit	Default Value	Description
Local Address Space 0 Burst Enable	0	Bursting disabled
Local Address Space 0 READY# Input Enable	0	READY# input disabled
Local Address Space 0 BTERM# Input Enable	0	BTERM# input disabled
Prefetch Count	00	Do not prefetch (disable)
Prefetch Counter Enable	1	Set to 1 (disabled by Prefetch Count=0)
NRAD Wait States	00010	Read Address to Data wait states
NRDD Wait States	00	Read Data to Data wait states
NXDA Wait States	01	Read/Write Data to Address wait states
NWAD Wait States	00010	Write Address to Data wait states
NWDD Wait States	00	Write Data to Data wait states
Local Address Space 0 Local Bus Width	10	32 bit bus width
Byte Ordering	1	Big Endian
Big Endian Byte Lane Mode	0	Use lanes [15:0], [7:0] in non 32 bit modes
Read Strobe Delay	01	Delay until assertion of RD#
Write Strobe Delay	01	Delay until assertion of WR#
Write Cycle Hold	00	Hold data after

Figure 4-5 : Default values of Space 0 Region Descriptor

5 FPGA Programming Hints

5.1 FPGA Design

Custom FPGA designs can be developed using a commercial version like Xilinx ISE Foundation or the ISE *WebPACK*, downloadable free of charge at www.xilinx.com/ise. Taking the VHDL example provided with the Engineering Documentation would be a good basis. After implementing the logic, the resulting .xsvf file can be downloaded to the configuration flash by the driver. A detailed description of the example files and how to generate the configuration bit stream file is part of the Engineering Documentation.

5.2 FPGA Pin Assignment

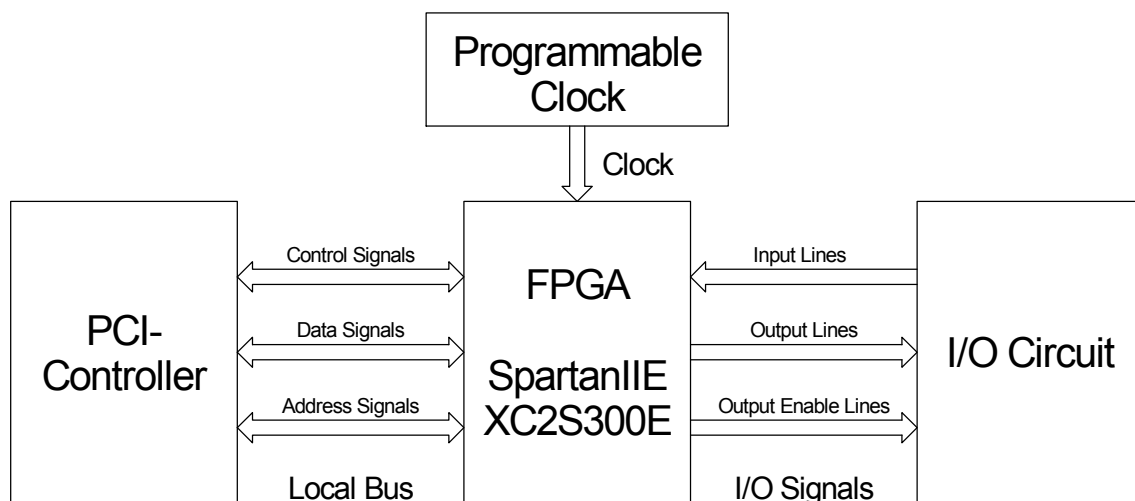

Figure 5-1 : FPGA Signals Block Diagram

5.2.1 Pin Assignment of Local Bus Control Signals

Signal	Pin	Description
LRESET#	T2	Local Reset
LRD#	W1	Local Read
LWR#	P1	Local Write
LADS#	L1	Local Address Strobe
LBE0#	AA18	Local Byte Enable 0
LBE1#	AB16	Local Byte Enable 1
LBE2#	Y13	Local Byte Enable 2
LBE3#	AA11	Local Byte Enable 3
LCS0#	R1	Local Chip Select 0
LCS1#	R2	Local Chip Select 1

Signal	Pin	Description
LCS2#	L2	Local Chip Select 2
LCS3#	U1	Local Chip Select 3
LINT1#	T1	Local Interrupt 1
LINT2#	U2	Local Interrupt 2
LBLAST#	M1	Local Burst Last
LRDY#	N2	Local Ready
LW_R#	Y2	Local Write/Read (low active for reads, high for writes)
LBTERM#	P2	Local Burst Terminate

Figure 5-2 : Pin Assignment Local Bus Control Signals

In the VHDL example code, low active signals have an 'n' as last character, instead of the '#'.

5.2.2 Pin Assignment of Local Bus Data Signals

Signal	Pin	Signal	Pin
LD 0	W7	LD 16	AB13
LD 1	V7	LD 17	Y11
LD 2	AA10	LD 18	P6
LD 3	P5	LD 19	N5
LD 4	Y10	LD 20	L3
LD 5	M4	LD 21	N4
LD 6	W10	LD 22	M3
LD 7	K3	LD 23	Y9
LD 8	M5	LD 24	AB10
LD 9	N6	LD 25	AA9
LD 10	V11	LD 26	P4
LD 11	AB15	LD 27	T5
LD 12	AA14	LD 28	AB9
LD 13	U10	LD 29	V6
LD 14	W11	LD 30	Y7
LD 15	U9	LD 31	AB8

Figure 5-3 : Pin Assignment Local Bus Data Signals

5.2.3 Pin Assignment of Local Bus Address Signals

Signal	Pin	Signal	Pin
LA 2	P3	LA 13	V4
LA 3	W6	LA 14	AB5
LA 4	T4	LA 15	R3
LA 5	AA7	LA 16	T3
LA 6	U4	LA 17	U3
LA 7	AB7	LA 18	V3
LA 8	AA6	LA 19	W3
LA 9	W5	LA 20	AB3
LA 10	AB6	LA 21	AA3
LA 11	Y5	LA 22	W2
LA 12	AA5	LA 23	V2

Figure 5-4 : Pin Assignment Local Bus Address Signals

5.2.4 Pin Assignment of Clock Signals

Signal	Pin	Description	Default values
BCLK	AA12	Buffered PCI Clock	PCI Clock from Carrier
CLK1	AB12	CLK1 Output of Clock Generator	50 MHz
CLK2	A11	CLK2 Output of Clock Generator	20 MHz
CLK3	C11	CLK3 Output of Clock Generator	10 MHz
CLK4	AB21	CLK4 Output of Clock Generator	1 MHz
CLK5	W22	CLK5 Output of Clock Generator	200 kHz
CLK6	U21	CLK6 Output of Clock Generator	(Off)

Figure 5-5 : Pin Assignment Clock Inputs

5.2.5 Pin Assignment of FPGA Input Lines

Signal	Pin	Signal	Pin
FPGA_IN 0	F1	FPGA_IN 32	E19
FPGA_IN 1	C1	FPGA_IN 33	E20
FPGA_IN 2	D2	FPGA_IN 34	F11
FPGA_IN 3	D3	FPGA_IN 35	F19
FPGA_IN 4	G3	FPGA_IN 36	N18
FPGA_IN 5	C5	FPGA_IN 37	N19
FPGA_IN 6	F5	FPGA_IN 38	J4
FPGA_IN 7	B7	FPGA_IN 39	M18
FPGA_IN 8	A9	FPGA_IN 40	M20
FPGA_IN 9	C8	FPGA_IN 41	J5
FPGA_IN 10	A14	FPGA_IN 42	L18
FPGA_IN 11	C12	FPGA_IN 43	H4
FPGA_IN 12	C9	FPGA_IN 44	U13
FPGA_IN 13	B10	FPGA_IN 45	V15
FPGA_IN 14	C15	FPGA_IN 46	U14
FPGA_IN 15	D15	FPGA_IN 47	V16
FPGA_IN 16	E10	FPGA_IN 48	V20
FPGA_IN 17	E13	FPGA_IN 49	L6
FPGA_IN 18	M19	FPGA_IN 50	U20
FPGA_IN 19	L20	FPGA_IN 51	T18
FPGA_IN 20	A15	FPGA_IN 52	AA13
FPGA_IN 21	B14	FPGA_IN 53	V12
FPGA_IN 22	L22	FPGA_IN 54	AB17
FPGA_IN 23	K22	FPGA_IN 55	U12
FPGA_IN 24	J22	FPGA_IN 56	AB18
FPGA_IN 25	A18	FPGA_IN 57	Y16
FPGA_IN 26	R21	FPGA_IN 58	W15
FPGA_IN 27	R22	FPGA_IN 59	AB20
FPGA_IN 28	E16	FPGA_IN 60	AA8
FPGA_IN 29	E17	FPGA_IN 61	N3
FPGA_IN 30	V21	FPGA_IN 62	W9
FPGA_IN 31	V22	FPGA_IN 63	V9

Figure 5-6 : Pin Assignment FPGA Input Lines

5.2.6 Pin Assignment of FPGA Output Lines

Signal	Pin	Signal	Pin
FPGA_OUT 0	E2	FPGA_OUT 32	B19
FPGA_OUT 1	E3	FPGA_OUT 33	C14
FPGA_OUT 2	B5	FPGA_OUT 34	C17
FPGA_OUT 3	B3	FPGA_OUT 35	D14
FPGA_OUT 4	A4	FPGA_OUT 36	K21
FPGA_OUT 5	F4	FPGA_OUT 37	J17
FPGA_OUT 6	A6	FPGA_OUT 38	J19
FPGA_OUT 7	C6	FPGA_OUT 39	J20
FPGA_OUT 8	A8	FPGA_OUT 40	G5
FPGA_OUT 9	B8	FPGA_OUT 41	F9
FPGA_OUT 10	D10	FPGA_OUT 42	G18
FPGA_OUT 11	A17	FPGA_OUT 43	G20
FPGA_OUT 12	A10	FPGA_OUT 44	V17
FPGA_OUT 13	D8	FPGA_OUT 45	U18
FPGA_OUT 14	D13	FPGA_OUT 46	U19
FPGA_OUT 15	D16	FPGA_OUT 47	K4
FPGA_OUT 16	D21	FPGA_OUT 48	T20
FPGA_OUT 17	E15	FPGA_OUT 49	K5
FPGA_OUT 18	L17	FPGA_OUT 50	J3
FPGA_OUT 19	K17	FPGA_OUT 51	P18
FPGA_OUT 20	D9	FPGA_OUT 52	Y15
FPGA_OUT 21	B12	FPGA_OUT 53	W14
FPGA_OUT 22	G21	FPGA_OUT 54	AA17
FPGA_OUT 23	E21	FPGA_OUT 55	AB19
FPGA_OUT 24	F22	FPGA_OUT 56	Y17
FPGA_OUT 25	D22	FPGA_OUT 57	W16
FPGA_OUT 26	N21	FPGA_OUT 58	W17
FPGA_OUT 27	N22	FPGA_OUT 59	Y19
FPGA_OUT 28	B15	FPGA_OUT 60	W8
FPGA_OUT 29	B17	FPGA_OUT 61	V8
FPGA_OUT 30	T21	FPGA_OUT 62	V10
FPGA_OUT 31	T22	FPGA_OUT 63	AB14

Figure 5-7 : Pin Assignment FPGA Output Lines

5.2.7 Pin Assignment of FPGA Output Enable Lines

Signal	Pin	Signal	Pin
FPGA_OE 0	D1	FPGA_OE 32	B18
FPGA_OE 1	A3	FPGA_OE 33	C13
FPGA_OE 2	A5	FPGA_OE 34	C16
FPGA_OE 3	F2	FPGA_OE 35	D12
FPGA_OE 4	F3	FPGA_OE 36	K18
FPGA_OE 5	B4	FPGA_OE 37	G4
FPGA_OE 6	D5	FPGA_OE 38	J18
FPGA_OE 7	B6	FPGA_OE 39	F20
FPGA_OE 8	C7	FPGA_OE 40	J21
FPGA_OE 9	D7	FPGA_OE 41	H18
FPGA_OE 10	B13	FPGA_OE 42	F10
FPGA_OE 11	A16	FPGA_OE 43	G19
FPGA_OE 12	B9	FPGA_OE 44	W18
FPGA_OE 13	E7	FPGA_OE 45	V19
FPGA_OE 14	C18	FPGA_OE 46	K6
FPGA_OE 15	E8	FPGA_OE 47	P19
FPGA_OE 16	E12	FPGA_OE 48	T19
FPGA_OE 17	E14	FPGA_OE 49	R18
FPGA_OE 18	J6	FPGA_OE 50	P17
FPGA_OE 19	L21	FPGA_OE 51	N20
FPGA_OE 20	C10	FPGA_OE 52	V13
FPGA_OE 21	A13	FPGA_OE 53	AA16
FPGA_OE 22	H21	FPGA_OE 54	Y18
FPGA_OE 23	F21	FPGA_OE 55	AA20
FPGA_OE 24	H22	FPGA_OE 56	V14
FPGA_OE 25	E22	FPGA_OE 57	AA19
FPGA_OE 26	P21	FPGA_OE 58	M6
FPGA_OE 27	M21	FPGA_OE 59	L5
FPGA_OE 28	A19	FPGA_OE 60	R5
FPGA_OE 29	B16	FPGA_OE 61	W13
FPGA_OE 30	P20	FPGA_OE 62	Y14
FPGA_OE 31	U22	FPGA_OE 63	AA15

Figure 5-8 : Pin Assignment FPGA Output Enable Lines

6 Configuration Hints

6.1 Big / Little Endian

- PCI – Bus (Little Endian)

Byte 0	AD[7..0]
Byte 1	AD[15..8]
Byte 2	AD[23..16]
Byte 3	AD[31..24]

- Every Local Address Space (0...3) and the Expansion ROM Space can be programmed to operate in Big or Little Endian Mode.

Big Endian		Little Endian	
32 Bit		32 Bit	
Byte 0	D[31..24]	Byte 0	D[7..0]
Byte 1	D[23..16]	Byte 1	D[15..8]
Byte 2	D[15..8]	Byte 2	D[23..16]
Byte 3	D[7..0]	Byte 3	D[31..24]
16 Bit upper lane		16 Bit	
Byte 0	D[31..24]	Byte 0	D[7..0]
Byte 1	D[23..16]	Byte 1	D[15..8]
16 Bit lower lane			
Byte 0	D[15..8]		
Byte 1	D[7..0]		
8 Bit upper lane		8 Bit	
Byte 0	D[31..24]	Byte 0	D[7..0]
8 Bit lower lane			
Byte 0	D[7..0]		

Figure 6-1 : Local Bus Little/Big Endian

Standard use of the TCP630 example design:

Local Address Space 0	32 bit bus in Big Endian Mode
Local Address Space 1	not used
Local Address Space 2	not used
Local Address Space 3	not used
Expansion ROM Space	not used

To change the Endian Mode use the Local Configuration Registers for the corresponding Space. Bit 24 of the according register sets the mode. A value of 1 indicates Big Endian and a value of 0 indicates Little Endian.

For further information please refer to the PCI9030 manual which is also part of the TCP630-ED Engineering Documentation.

Use the PCI Base Address 0 + Offset or PCI Base Address 1 + Offset:

Short cut	Offset	Name
LAS0BRD	0x28	Local Address Space 0 Bus Region Description Register
LAS1BRD	0x2C	Local Address Space 0 Bus Region Description Register
LAS2BRD	0x30	Local Address Space 0 Bus Region Description Register
LAS3BRD	0x34	Local Address Space 0 Bus Region Description Register
EROMBRD	0x38	Expansion ROM Bus Region Description Register

You could also use the PCI - Base Address 1 I/O Mapped Configuration Registers.

6.2 Clock Programming

The CY27EE16 is programmed over a serial 2-wire programming interface with the serial clock signal SCLK and the serial data signal SDAT. These two signals are directly controlled by the PLX PCI9030, the SDA signal by GPIO7 and SCL by EESK. Because of the shared EESK signal, the serial configuration EEPROM and the CY27EE16 cannot be accessed simultaneously.

The CY27EE16 is addressed as a group of ten slave devices on the 2-wire bus. The address of the clock configuration EEPROM is 0x68. Changes of the clock configuration by writing to the SRAM at address 0x69 should only be done with caution, as these changes take immediately effect at the clock outputs. This could cause problems by the occurrence of glitches. Especially the LCLK input of the PCI9030, which is the CLK1 signal on the board, should never be changed during operation (recommendation by PLX).

For the same reason a soft reset of the device should not be activated after reprogramming the CY27EE16 clock configuration EEPROM. Soft reset is generated by setting the MSB in the SRAM space at offset 0x00 followed by an I2C stop. This will update the SRAM as it is done at power-up.

The CLK1 output of the CY27EE16 must never be switched off (Off or Hi-Z) and the frequency has to be within 0-60 MHz. When the local clock is switched off, the PCI9030 will not work and the CY27EE16 can't be reprogrammed any more. The board would have to be sent to the manufacturer for repair.

A detailed register description and the exact programming timing can be found in the datasheet of the CY27EE16. This is part of the TCP630-ED Engineering Documentation and is also available at www.cypress.com, as well as the 'CyberClocks' software, a tool which helps calculating the register values.

The drivers available from TEWS TECHNOLOGIES provide routines for easy setting of the CY27EE16 registers.

6.2.1 Default Clock Programming

Description	Default values
CLK1 Output of Clock Generator	50 MHz
CLK2 Output of Clock Generator	20 MHz
CLK3 Output of Clock Generator	10 MHz
CLK4 Output of Clock Generator	1 MHz
CLK5 Output of Clock Generator	200 kHz
CLK6 Output of Clock Generator	(Off)

Figure 6-2 : Default values of clock outputs (at delivery)

Offset	Description	Default values
0x09	CLKOE control	0x6F
0x0C	DIV1SRC mux and DIV1N divider	0x64
0x10	Input Pin Control Registers	0x50
0x11	Write Protect Registers	0x04
0x12	Input crystal oscillator drive control	0x20
0x13	Input load capacitor control	0x00
0x14	ADC Register	0x00
0x40	Charge Pump and PB counter	0xC0
0x41	Charge Pump and PB counter	0x03
0x42	PO counter, Q counter	0x81
0x44	Crosspoint switch matrix control	0x42
0x45	Crosspoint switch matrix control	0x9F
0x46	Crosspoint switch matrix control	0x3F
0x47	DIV2SRC mux and DIV2N divider	0xE4

Figure 6-3 : Default register values (at delivery)

7 Installation

7.1 Pull Up Voltage

The voltage of the pull up resistors can be 3.3V or alternatively 5V, specified by jumper J1. The default pull up voltage is 3.3V.

J1 Jumper Position	Pull Up Voltage
1 – 2	3.3V (default)
2 – 3	5V

Figure 7-1 : Pull Up Voltage Jumper Setting

7.2 I/O Interface

7.2.1 TTL I/O Interface

Each of the 64 (TCP630-10) or 32 (TCP630-12) TTL I/O lines is realized with two 74LVT126 bus buffers as an interface to the FPGA pins. The logic levels of the buffers are TTL compatible, meaning that the minimum high level is 2.0V and the maximum low level is 0.8V. The nominal output high voltage is 3.3V.

The buffer outputs are followed by 47Ω serial resistors for signal integrity reasons. The 4.7kΩ pull up resistors guaranty a high level when outputs are tristate and not driven externally.

As an option the pull up voltage can be set to 5V by jumper J1 to (weakly) drive a higher voltage than 3.3V by setting the output to tristate. This means, instead of toggling the corresponding bit of the output register, the output enable register bit is set to 0 for an output high level or 1 to pull the output low (the OUT_REG bit is '0'). For example when connecting to a standard 5V CMOS logic input (not TTL compatible levels), a high level of minimum 3.5V is required.

Please note that the pull up resistor can only drive high impedance inputs.

A TVS array protects against ESD shocks.

See the following figure for more information of the TTL I/O circuitry.

Please note that the length (and consequently the capacitance) of a flat cable, connected to the TCP630 module, should be kept as short as possible to prevent large cross talk.

To reduce the cross talk on the TCP630, not all 64 I/O lines should be switched at the same time. The output lines could be switched in 8 groups of 8 signals in steps of 12.5ns (@ 40 MHz clock), as shown in the VHDL example. After about 100ns the switching process is completed.

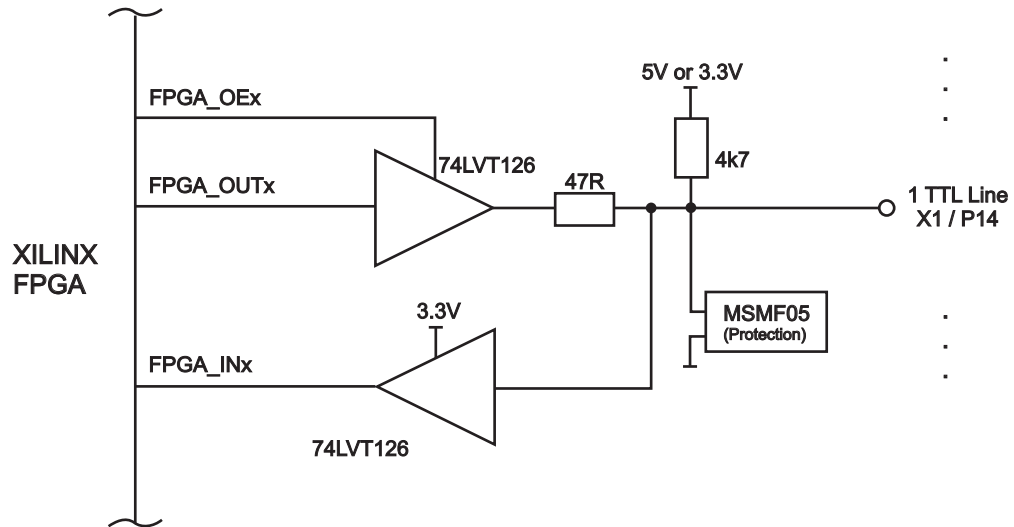

Figure 7-2 : TTL I/O Interface

7.2.2 Differential I/O Interface

Each of the 32 (TCP630-11) or 16 (TCP630-12) differential I/O line pairs is realized with an input, output and output enable pin at the XILINX FPGA, connected to a MAX3078E, an ESD-protected RS485/RS422 transceiver, and a 120Ω termination resistor.

See the following figure for more information of the differential I/O circuitry.

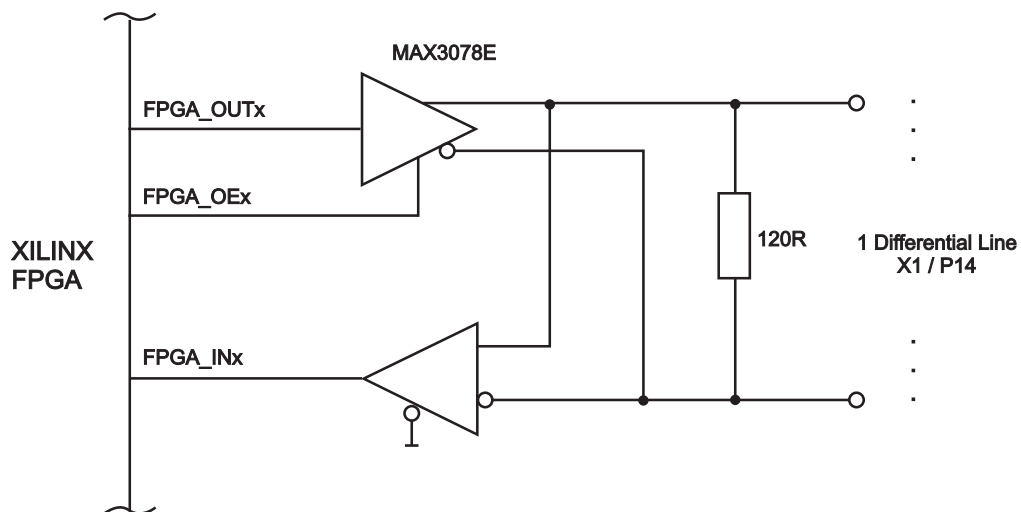

Figure 7-3 : Differential I/O Interface

7.3 Back I/O Configuration

The configuration of J2 “Back I/O” connector lines [57..64] can be changed to ground instead of port 7 signals by change of zero ohm resistors.

For removing/mounting zero ohm resistors, work on a grounded, static free work surface.

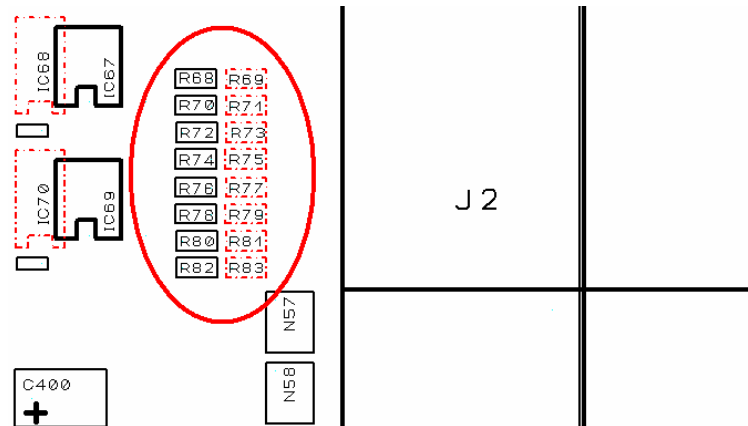

Figure 7-4 : Jumper positions for ground option

Back I/O Line	Signal	Jumper Position
57	ground	R70
	IO_56 / IO_28A/- (default)	R72
58	ground	R66
	I/O_57 / IO_28B/+ (default)	R67
59	ground	R74
	I/O_58 / IO_29A/- (default)	R76
60	ground	R71
	I/O_59 / IO_29B/+ (default)	R73
61	ground	R78
	I/O_60 / IO_30A/- (default)	R80
62	ground	R75
	I/O_61 / IO_30B/+ (default)	R77
63	ground	R82
	I/O_62 / IO_31A/- (default)	R83
64	ground	R79
	I/O_63 / IO_31B/+ (default)	R81

Figure 7-5 : Jumper positions for Back I/O options

Caution: Never make simultaneous connections on both jumper positions of one I/O line. Serious damage of the module is possible.

7.4 FPGA Debug Connector

The FPGA in-circuit debug connector X2 is not populated by default. It lets the user directly connect a JTAG interface cable to the JTAG pins of the FPGA for readback and real-time debugging of the FPGA design (using Xilinx “ChipScope”). The Platform Flash is not part of this JTAG chain; it is only programmable via the PCI9030 GPIO.

A through hole, vertical connector with 7 x 2 pins and 2 mm pitch (e.g.: Molex 87831-1420, or others) can be mounted. Pin 1 is marked by a squared pad (see next figure). The connector pinning is compatible for the Xilinx cables (e.g. Parallel Cable IV, or others).

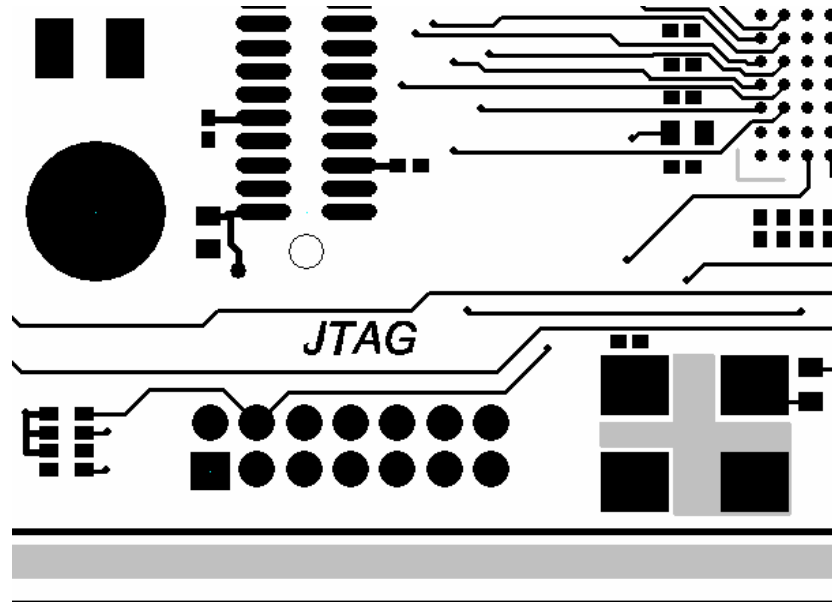

Figure 7-6 : Debug Connector (Bottom View)

Pin	Short	Description
1,3,5,7,9,11,13	GND	Digital Ground
2	V _{REF}	Target Reference Voltage (3.3V)
4	TMS	Test Mode Select
6	TCK	Test Clock
8	TDO	Test Data Out
10	TDI	Test Data In
12,14	n.c.	Not connected

Figure 7-7 : Debug Connector Pinout

7.5 PIM Module Slot

Instead of a front I/O Connector the TCP630 offers a PIM module slot. This allows a wide range of connectors to be used with the TCP630 and special I/O solutions can be easily applied with the TCP630.

The PIM standard is described in: “PMC I/O Module Standard (Vita 36)”, available at www.vita.com.

A PIM module is a 74mm x 69mm module with a PMC bezel and two EIA E700 AAAB connectors (as on PMCs). One of these connectors provides the power supply (3.3V, 5V & $\pm 12V$) for the PIM module, the other connector provides the I/O signals to the host board.

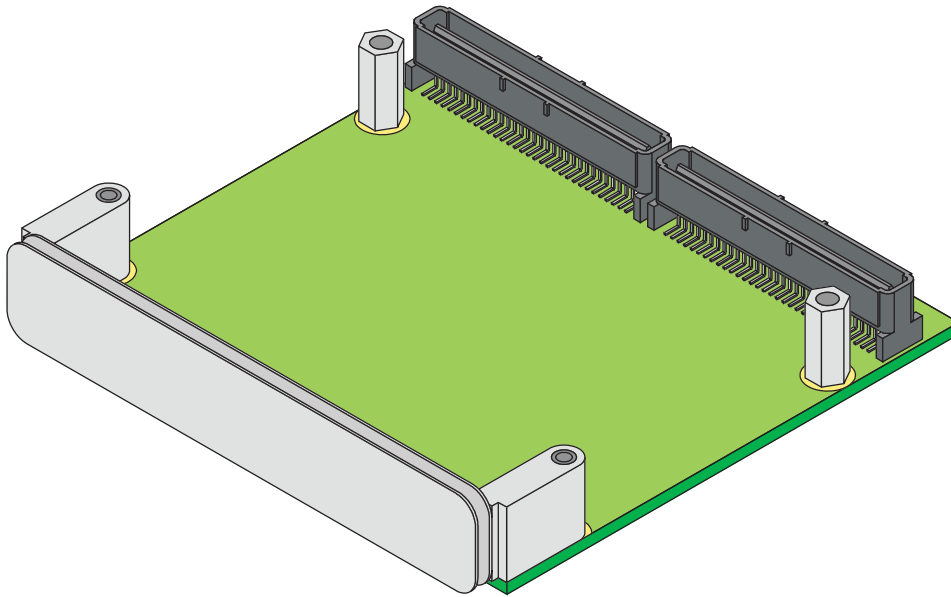

Figure 7-8 : A PIM Module

The PIM module can adapt the TCP630 to various I/O standards, either mechanical (connector) or electrical. A collection of PIM modules with standard I/O connectors are available from TEWS.

Example: A TPIM003 with an HD68 connector would offer all 64 FPGA I/O lines at the connector, with a pin assignment that is compatible to a TPMC630.

8 Pin Assignment – I/O Connector

The TCP630 does not provide a direct front panel I/O, but it offers a PIM module slot. This allows very versatile I/O solutions with a wide range of connectors. The TCP630-2x also offer rear I/O via the J2 connector.

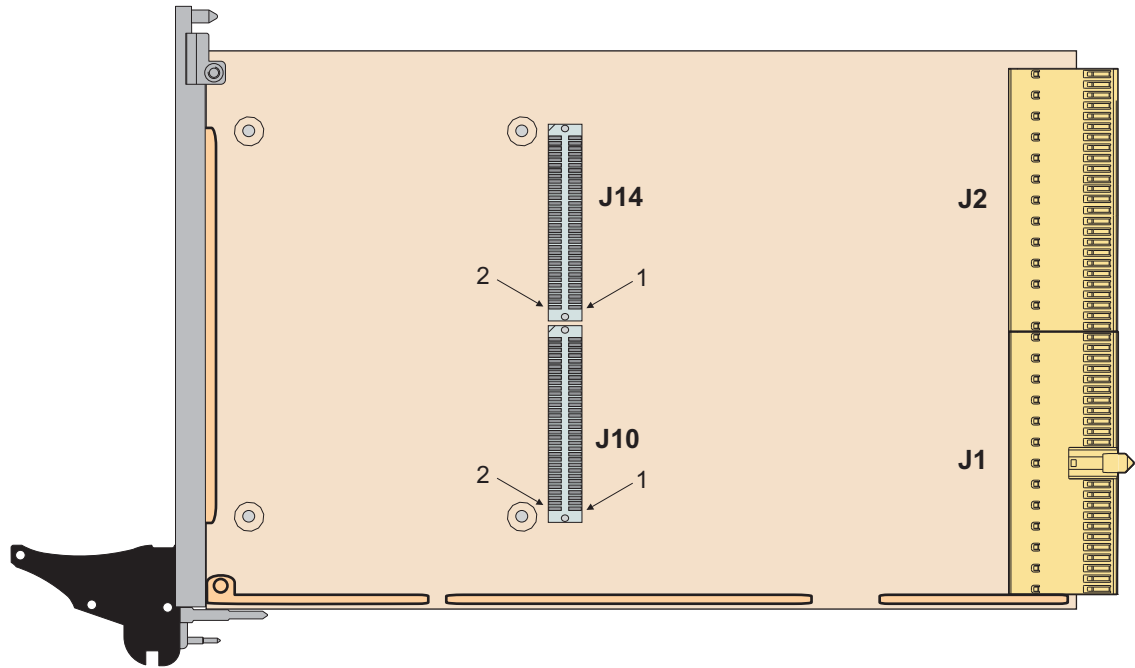

Figure 8-1 : Connector Positions

8.1 PIM Slot Connectors

8.1.1 J10 Assignment

Pin	Signal	Pin	Signal
1	-	2	+12V
3	-	4	-
5	+5V	6	-
7	-	8	-
9	-	10	+3.3V
11	-	12	-
13	GND	14	-
15	-	16	-
17	-	18	GND
19	-	20	-
21	+5V	22	-
23	-	24	-
25	-	26	+3.3V
27	-	28	-
29	GND	30	-
31	-	32	-
33	-	34	GND
35	-	36	-
37	+5V	38	-
39	-	40	-
41	-	42	+3.3V
43	-	44	-
45	GND	46	-
47	-	48	-
49	-	50	GND
51	-	52	-
53	+5V	54	-
55	-	56	-
57	-	58	+3.3V
59	-	60	-
61	-12V	62	-
63	-	64	-

Figure 8-2 : Pin Assignment J10 Connector

8.1.2 J14 Assignment TCP630-x0

Pin	Signal	Level	Pin	Signal	Level
1	IO_0	TTL	2	IO_1	TTL
3	IO_2	TTL	4	IO_3	TTL
5	IO_4	TTL	6	IO_5	TTL
7	IO_6	TTL	8	IO_7	TTL
9	IO_8	TTL	10	IO_9	TTL
11	IO_10	TTL	12	IO_11	TTL
13	IO_12	TTL	14	IO_13	TTL
15	IO_14	TTL	16	IO_15	TTL
17	IO_16	TTL	18	IO_17	TTL
19	IO_18	TTL	20	IO_19	TTL
21	IO_20	TTL	22	IO_21	TTL
23	IO_22	TTL	24	IO_23	TTL
25	IO_24	TTL	26	IO_25	TTL
27	IO_26	TTL	28	IO_27	TTL
29	IO_28	TTL	30	IO_29	TTL
31	IO_30	TTL	32	IO_31	TTL
33	IO_32	TTL	34	IO_33	TTL
35	IO_34	TTL	36	IO_35	TTL
37	IO_36	TTL	38	IO_37	TTL
39	IO_38	TTL	40	IO_39	TTL
41	IO_40	TTL	42	IO_41	TTL
43	IO_42	TTL	44	IO_43	TTL
45	IO_44	TTL	46	IO_45	TTL
47	IO_46	TTL	48	IO_47	TTL
49	IO_48	TTL	50	IO_49	TTL
51	IO_50	TTL	52	IO_51	TTL
53	IO_52	TTL	54	IO_53	TTL
55	IO_54	TTL	56	IO_55	TTL
57	IO_56	TTL	58	IO_57	TTL
59	IO_58	TTL	60	IO_59	TTL
61	IO_60	TTL	62	IO_61	TTL
63	IO_62	TTL	64	IO_63	TTL

Figure 8-3 : Pin Assignment J14 Connector TCP630-x0

8.1.3 J14 Assignment TCP630-x1

Pin	Signal	Level	Pin	Signal	Level
1	IO_0A/-	Diff. -	2	IO_0B/+	Diff. +
3	IO_1A/-	Diff. -	4	IO_1B/+	Diff. +
5	IO_2A/-	Diff. -	6	IO_2B/+	Diff. +
7	IO_3A/-	Diff. -	8	IO_3B/+	Diff. +
9	IO_4A/-	Diff. -	10	IO_4B/+	Diff. +
11	IO_5A/-	Diff. -	12	IO_5B/+	Diff. +
13	IO_6A/-	Diff. -	14	IO_6B/+	Diff. +
15	IO_7A/-	Diff. -	16	IO_7B/+	Diff. +
17	IO_8A/-	Diff. -	18	IO_8B/+	Diff. +
19	IO_9A/-	Diff. -	20	IO_9B/+	Diff. +
21	IO_10A/-	Diff. -	22	IO_10B/+	Diff. +
23	IO_11A/-	Diff. -	24	IO_11B/+	Diff. +
25	IO_12A/-	Diff. -	26	IO_12B/+	Diff. +
27	IO_13A/-	Diff. -	28	IO_13B/+	Diff. +
29	IO_14A/-	Diff. -	30	IO_14B/+	Diff. +
31	IO_15A/-	Diff. -	32	IO_15B/+	Diff. +
33	IO_16A/-	Diff. -	34	IO_16B/+	Diff. +
35	IO_17A/-	Diff. -	36	IO_17B/+	Diff. +
37	IO_18A/-	Diff. -	38	IO_18B/+	Diff. +
39	IO_19A/-	Diff. -	40	IO_19B/+	Diff. +
41	IO_20A/-	Diff. -	42	IO_20B/+	Diff. +
43	IO_21A/-	Diff. -	44	IO_21B/+	Diff. +
45	IO_22A/-	Diff. -	46	IO_22B/+	Diff. +
47	IO_23A/-	Diff. -	48	IO_23B/+	Diff. +
49	IO_24A/-	Diff. -	50	IO_24B/+	Diff. +
51	IO_25A/-	Diff. -	52	IO_25B/+	Diff. +
53	IO_26A/-	Diff. -	54	IO_26B/+	Diff. +
55	IO_27A/-	Diff. -	56	IO_27B/+	Diff. +
57	IO_28A/-	Diff. -	58	IO_28B/+	Diff. +
59	IO_29A/-	Diff. -	60	IO_29B/+	Diff. +
61	IO_30A/-	Diff. -	62	IO_30B/+	Diff. +
63	IO_31A/-	Diff. -	64	IO_31B/+	Diff. +

Figure 8-4 : Pin Assignment J14 Connector TCP630-x1

8.1.4 J14 Assignment TCP630-x2

Pin	Signal	Level	Pin	Signal	Level
1	IO_0A/-	Diff. -	2	IO_0B/+	Diff. +
3	IO_1A/-	Diff. -	4	IO_1B/+	Diff. +
5	IO_2A/-	Diff. -	6	IO_2B/+	Diff. +
7	IO_3A/-	Diff. -	8	IO_3B/+	Diff. +
9	IO_4A/-	Diff. -	10	IO_4B/+	Diff. +
11	IO_5A/-	Diff. -	12	IO_5B/+	Diff. +
13	IO_6A/-	Diff. -	14	IO_6B/+	Diff. +
15	IO_7A/-	Diff. -	16	IO_7B/+	Diff. +
17	IO_8A/-	Diff. -	18	IO_8B/+	Diff. +
19	IO_9A/-	Diff. -	20	IO_9B/+	Diff. +
21	IO_10A/-	Diff. -	22	IO_10B/+	Diff. +
23	IO_11A/-	Diff. -	24	IO_11B/+	Diff. +
25	IO_12A/-	Diff. -	26	IO_12B/+	Diff. +
27	IO_13A/-	Diff. -	28	IO_13B/+	Diff. +
29	IO_14A/-	Diff. -	30	IO_14B/+	Diff. +
31	IO_15A/-	Diff. -	32	IO_15B/+	Diff. +
33	IO_32	TTL	34	IO_33	TTL
35	IO_34	TTL	36	IO_35	TTL
37	IO_36	TTL	38	IO_37	TTL
39	IO_38	TTL	40	IO_39	TTL
41	IO_40	TTL	42	IO_41	TTL
43	IO_42	TTL	44	IO_43	TTL
45	IO_44	TTL	46	IO_45	TTL
47	IO_46	TTL	48	IO_47	TTL
49	IO_48	TTL	50	IO_49	TTL
51	IO_50	TTL	52	IO_51	TTL
53	IO_52	TTL	54	IO_53	TTL
55	IO_54	TTL	56	IO_55	TTL
57	IO_56	TTL	58	IO_57	TTL
59	IO_58	TTL	60	IO_59	TTL
61	IO_60	TTL	62	IO_61	TTL
63	IO_62	TTL	64	IO_63	TTL

Figure 8-5 : Pin Assignment J14 Connector TCP630-x2

8.2 Back I/O J2 Connector

8.2.1 Back I/O Assignment TCP630-20 / -40

Pos.	F	E	D	C	B	A
22	GND	not used	not used	not used	not used	not used
21	GND	not used	not used	not used	not used	not used
20	GND	not used	not used	not used	not used	not used
19	GND	not used	not used	not used	not used	not used
18	GND	not used	not used	not used	not used	not used
17	GND	not used	not used	not used	not used	not used
16	GND	not used	not used	not used	not used	not used
15	GND	not used	not used	not used	not used	not used
14	GND	+5V	+5V	+3,3V	+3,3V	+3,3V
13	GND	IO_0	IO_1	IO_2	IO_3	IO_4
12	GND	IO_5	IO_6	IO_7	IO_8	IO_9
11	GND	IO_10	IO_11	IO_12	IO_13	IO_14
10	GND	IO_15	IO_16	IO_17	IO_18	IO_19
9	GND	IO_20	IO_21	IO_22	IO_23	IO_24
8	GND	IO_25	IO_26	IO_27	IO_28	IO_29
7	GND	IO_30	IO_31	IO_32	IO_33	IO_34
6	GND	IO_35	IO_36	IO_37	IO_38	IO_39
5	GND	IO_40	IO_41	IO_42	IO_43	IO_44
4	GND	IO_45	IO_46	IO_47	IO_48	IO_49
3	GND	IO_50	IO_51	IO_52	IO_53	IO_54
2	GND	IO_55	IO_56	IO_57	IO_58	IO_59
1	GND	IO_60	IO_61	IO_62	IO_63	VI/O

Figure 8-6 : Pin Assignment J2 I/O Connector TCP630-20 / -40

8.2.2 Back I/O Assignment TCP630-21 / -41

Pos.	F	E	D	C	B	A
22	GND	not used	not used	not used	not used	not used
21	GND	not used	not used	not used	not used	not used
20	GND	not used	not used	not used	not used	not used
19	GND	not used	not used	not used	not used	not used
18	GND	not used	not used	not used	not used	not used
17	GND	not used	not used	not used	not used	not used
16	GND	not used	not used	not used	not used	not used
15	GND	not used	not used	not used	not used	not used
14	GND	+5V	+5V	+3,3V	+3,3V	+3,3V
13	GND	IO_0A/-	IO_0B/+	IO_1A/-	IO_1B/+	IO_2A/-
12	GND	IO_2B/+	IO_3A/-	IO_3B/+	IO_4A/-	IO_4A/+
11	GND	IO_5A/-	IO_5B/+	IO_6A/-	IO_6B/+	IO_7A/-
10	GND	IO_7B/+	IO_8A/-	IO_8B/+	IO_9A/-	IO_9A/+
9	GND	IO_10A/-	IO_10B/+	IO_11A/-	IO_11B/+	IO_12A/-
8	GND	IO_12B/+	IO_13A/-	IO_13B/+	IO_14A/-	IO_14A/+
7	GND	IO_15A/-	IO_15B/+	IO_16A/-	IO_16B/+	IO_17A/-
6	GND	IO_17B/+	IO_18A/-	IO_18B/+	IO_19A/-	IO_19A/+
5	GND	IO_20A/-	IO_20B/+	IO_21A/-	IO_21B/+	IO_22A/-
4	GND	IO_22B/+	IO_23A/-	IO_23B/+	IO_24A/-	IO_24A/+
3	GND	IO_25A/-	IO_25B/+	IO_26A/-	IO_26B/+	IO_27A/-
2	GND	IO_27B/+	IO_28A/-	IO_28B/+	IO_29A/-	IO_29A/+
1	GND	IO_30A/-	IO_30B/+	IO_31A/-	IO_31B/+	VI/O

Figure 8-7 : Pin Assignment J2 I/O Connector TCP630-21 / -41

8.2.3 Back I/O Assignment TCP630-22 / -42

Pos.	F	E	D	C	B	A
22	GND	not used	not used	not used	not used	not used
21	GND	not used	not used	not used	not used	not used
20	GND	not used	not used	not used	not used	not used
19	GND	not used	not used	not used	not used	not used
18	GND	not used	not used	not used	not used	not used
17	GND	not used	not used	not used	not used	not used
16	GND	not used	not used	not used	not used	not used
15	GND	not used	not used	not used	not used	not used
14	GND	+5V	+5V	+3,3V	+3,3V	+3,3V
13	GND	IO_0A/-	IO_0B/+	IO_1A/-	IO_1B/+	IO_2A/-
12	GND	IO_2B/+	IO_3A/-	IO_3B/+	IO_4A/-	IO_4A/+
11	GND	IO_5A/-	IO_5B/+	IO_6A/-	IO_6B/+	IO_7A/-
10	GND	IO_7B/+	IO_8A/-	IO_8B/+	IO_9A/-	IO_9A/+
9	GND	IO_10A/-	IO_10B/+	IO_11A/-	IO_11B/+	IO_12A/-
8	GND	IO_12B/+	IO_13A/-	IO_13B/+	IO_14A/-	IO_14A/+
7	GND	IO_15A/-	IO_15B/+	IO_32	IO_33	IO_34
6	GND	IO_35	IO_36	IO_37	IO_38	IO_39
5	GND	IO_40	IO_41	IO_42	IO_43	IO_44
4	GND	IO_45	IO_46	IO_47	IO_48	IO_49
3	GND	IO_50	IO_51	IO_52	IO_53	IO_54
2	GND	IO_55	IO_56	IO_57	IO_58	IO_59
1	GND	IO_60	IO_61	IO_62	IO_63	VI/O

Figure 8-8 : Pin Assignment J2 I/O Connector TCP630-22 / -42