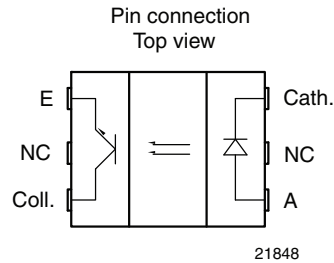




Subminiature Transmissive Optical Sensor with Transistor Output



19601



DESCRIPTION

The TCPT1300X01 is a compact transmissive sensor that includes an infrared emitter and a phototransistor detector, located face-to-face in a surface mount package.

FEATURES

- Package type: surface mount
- Detector type: phototransistor
- Dimensions (L x W x H in mm): 5.5 x 4 x 4
- AEC-Q101 qualified
- Gap (in mm): 3
- Aperture (in mm): 0.3
- Typical output current under test: $I_C = 0.6 \text{ mA}$
- Emitter wavelength: 950 nm
- Moisture sensitivity level (MSL): 1
- Compliant to RoHS Directive 2002/95/EC and in accordance to WEEE 2002/96/EC



Note

** Please see document "Vishay Material Category Policy": www.vishay.com/doc?99902

APPLICATIONS

- Automotive optical sensors
- Accurate position sensor for encoder
- Detection of motion speed

PRODUCT SUMMARY				
PART NUMBER	GAP WIDTH (mm)	APERTURE WIDTH (mm)	TYPICAL OUTPUT CURRENT UNDER TEST ⁽¹⁾ (mA)	DAYLIGHT BLOCKING FILTER INTEGRATED
TCPT1300X01	3	0.3	0.6	No

Note

- Conditions like in table basic characteristics/coupler

ORDERING INFORMATION			
ORDERING CODE	PACKAGING	VOLUME ⁽¹⁾	REMARKS
TCPT1300X01	Tape and reel	MOQ: 2000 pcs, 2000 pcs/reel	Drypack, MSL 1

Note

- MOQ: minimum order quantity



ABSOLUTE MAXIMUM RATINGS (T _{amb} = 25 °C, unless otherwise specified)				
PARAMETER	TEST CONDITION	SYMBOL	VALUE	UNIT
COUPLER				
Total power dissipation	T _{amb} ≤ 95 °C	P _{tot}	37.5	mW
Junction temperature		T _j	110	°C
Ambient temperature range		T _{amb}	- 40 to + 105	°C
Storage temperature range		T _{stg}	- 40 to + 125	°C
Soldering temperature	In accordance with fig. 16	T _{sd}	260	°C
INPUT (EMITTER)				
Reverse voltage		V _R	5	V
Forward current	T _{amb} ≤ 95 °C	I _F	25	mA
Forward surge current	t _p ≤ 10 μs	I _{FSM}	200	mA
Power dissipation	T _{amb} ≤ 95 °C	P _V	37.5	mW
OUTPUT (DETECTOR)				
Collector emitter voltage		V _{CEO}	20	V
Emitter collector voltage		V _{ECO}	7	V
Collector current		I _C	20	mA
Collector dark current	T _{amb} = 85 °C, V _{CE} = 5 V	I _{CEO}	3.3	μA

ABSOLUTE MAXIMUM RATINGS

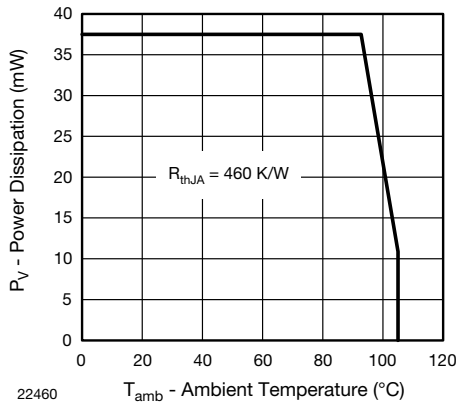


Fig. 1 - Power Dissipation Limit vs. Ambient Temperature

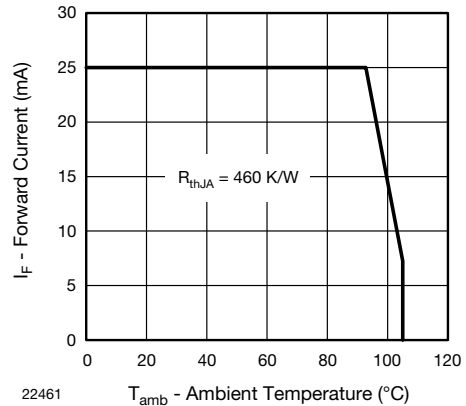


Fig. 2 - Forward Current Limit vs. Ambient Temperature

BASIC CHARACTERISTICS ($T_{amb} = 25\text{ }^{\circ}\text{C}$, unless otherwise specified)						
PARAMETER	TEST CONDITION	SYMBOL	MIN.	TYP.	MAX.	UNIT
COUPLER						
Collector current	$V_{CE} = 5\text{ V}$, $I_F = 15\text{ mA}$	I_C	300	600		μA
Collector emitter saturation voltage	$I_F = 15\text{ mA}$, $I_C = 0.05\text{ mA}$	V_{CEsat}			0.4	V
INPUT (EMITTER)						
Forward voltage	$I_F = 15\text{ mA}$	V_F	11	.2	1.4	V
Reverse current	$V_R = 5\text{ V}$	I_R			10	μA
Junction capacitance	$V_R = 0\text{ V}$, $f = 1\text{ MHz}$	C_j		25		pF
OUTPUT (DETECTOR)						
Collector emitter voltage I_C	$I_C = 1\text{ mA}$	V_{CEO}	20			V
Emitter collector voltage	$I_E = 100\text{ }\mu\text{A}$	V_{ECO}	7V			
Collector dark current	$V_{CE} = 25\text{ V}$, $I_F = 0\text{ A}$, $E = 0\text{ lx}$	I_{CEO}		1	100	nA
SWITCHING CHARACTERISTICS						
Rise time	$I_C = 0.3\text{ mA}$, $V_{CE} = 5\text{ V}$, $R_L = 100\text{ }\Omega$ (see figure 3)	t_r		20	150	μs
Fall time	$I_C = 0.3\text{ mA}$, $V_{CE} = 5\text{ V}$, $R_L = 100\text{ }\Omega$ (see figure 3)	t_f		30	150	μs

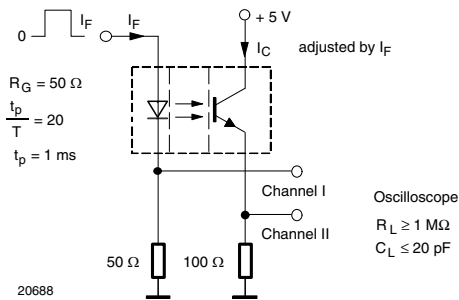
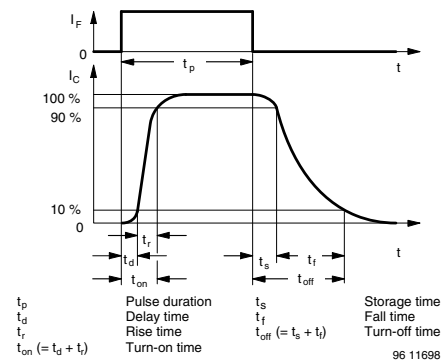

 Fig. 3 - Test Circuit for t_r and t_f


Fig. 4 - Switching Times

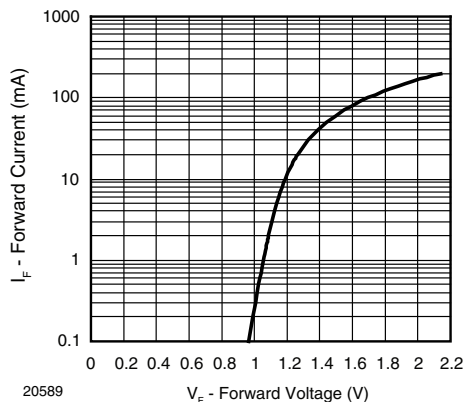
BASIC CHARACTERISTICS ($T_{amb} = 25\text{ }^{\circ}\text{C}$, unless otherwise specified)


Fig. 5 - Forward Current vs. Forward Voltage

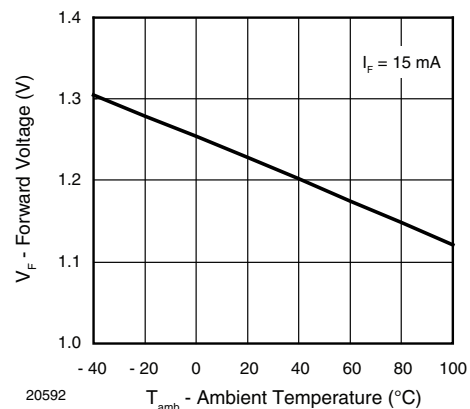


Fig. 6 - Forward Voltage vs. Ambient Temperature

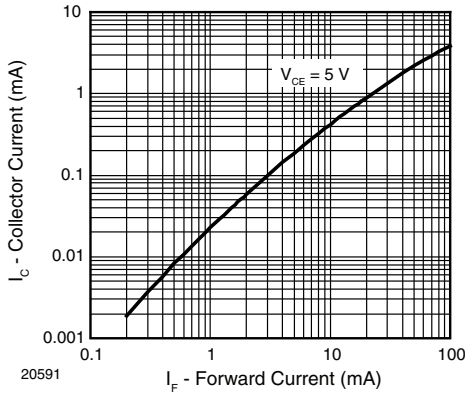


Fig. 7 - Collector Current vs. Forward Current

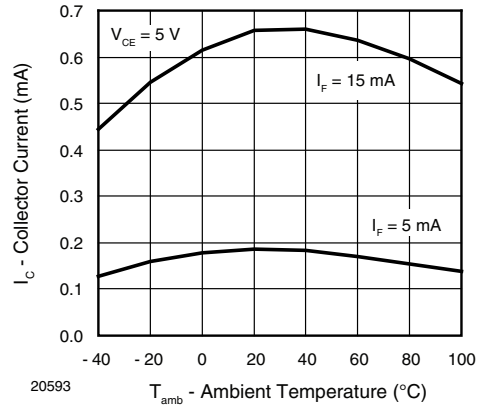


Fig. 10 - Collector Current vs. Ambient Temperature

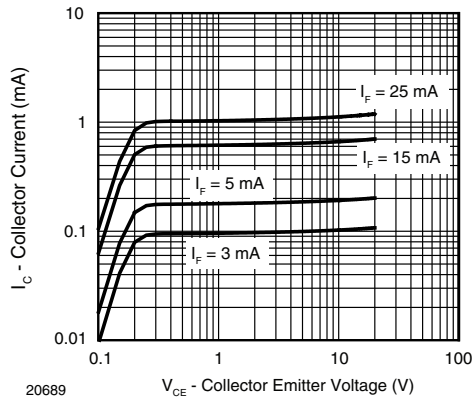


Fig. 8 - Collector Current vs. Collector Emitter Voltage

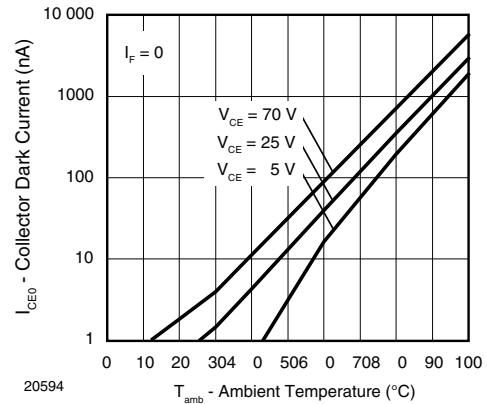


Fig. 11 - Collector Dark Current vs. Ambient Temperature

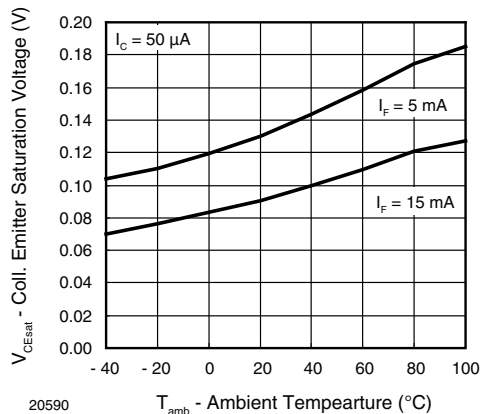


Fig. 9 - Collector Emitter Saturation Voltage vs. Ambient Temperature

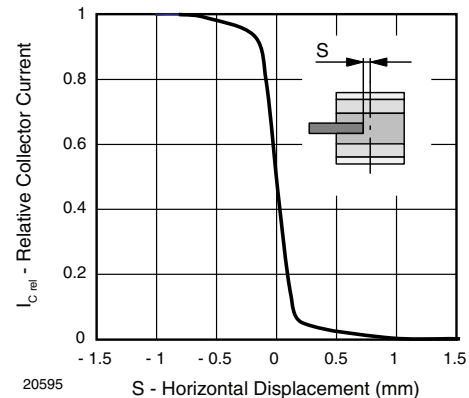


Fig. 12 - Relative Collector Current vs. Horizontal Displacement

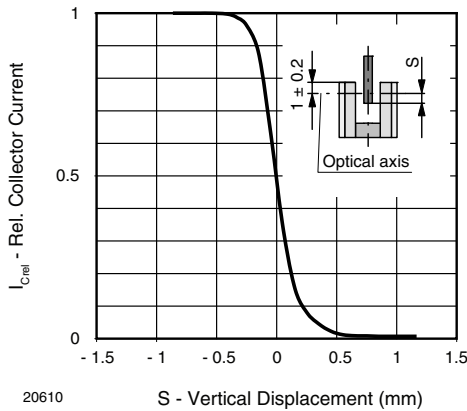


Fig. 13 - Relative Collector Current vs. Vertical Displacement

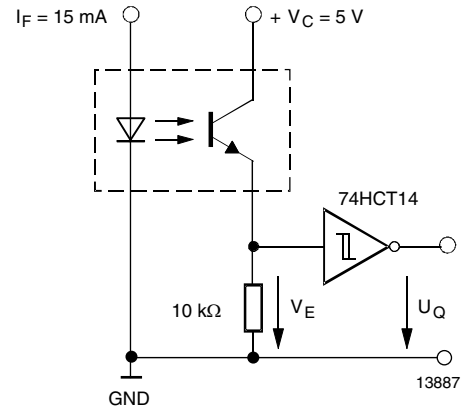


Fig. 15 - Application example

REFLOW SOLDER PROFILE

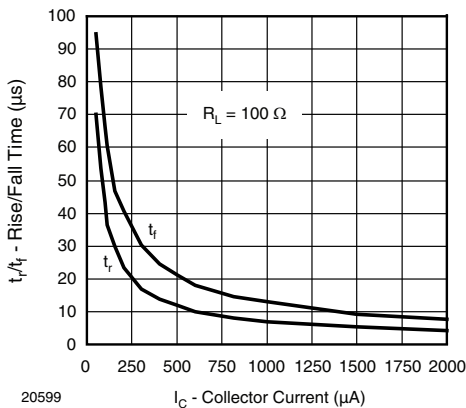


Fig. 14 - Rise/Fall Time vs. Collector Current

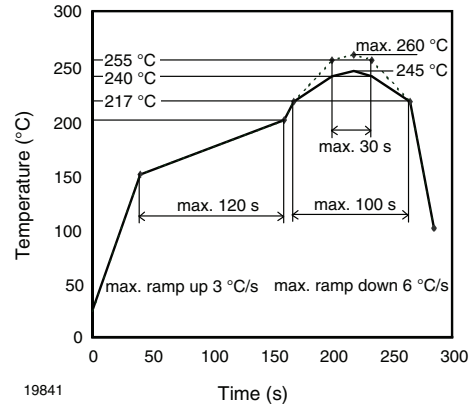


Fig. 16 - Lead (Pb)-free Reflow Solder Profile acc. J-STD-020

FLOOR LIFE

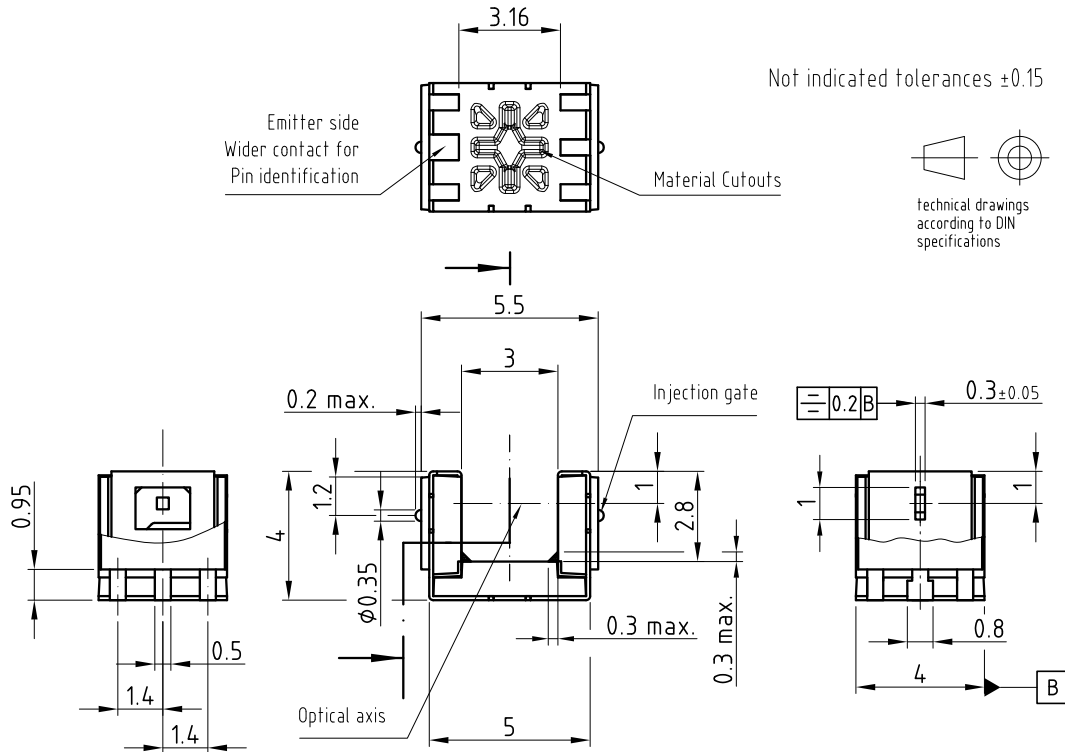
No time limit.
Moisture sensitivity level (MSL) 1, acc. JEDEC, J-STD-020.

RELIABILITY TESTS IN REFERENCE TO AEC-Q101 RELEASE			
TEST	CONDITION	DURATION	LOT SIZE - REJECTS
High temperature storage	$T_{stg} (max.) = 100\text{ }^{\circ}\text{C}$	1000 h	3 x 50 pcs - 0 pcs
Low temperature storage	$T_{stg} (min.) = -40\text{ }^{\circ}\text{C}$	1000 h	3 x 50 pcs - 0 pcs
Temperature cycling	$-40\text{ }^{\circ}\text{C}/+100\text{ }^{\circ}\text{C}$	1000 x	3 x 77 pcs - 0 pcs
H3TRB	85 °C/85 % RH, emitters: $V_R = 4\text{ V}$, detectors: $V_{CE0} = 5\text{ V}$	1000 h	3 x 77 pcs - 0 pcs
Intermittent operational life	Emitters: $I_F = 80\text{ mA DC}$, detectors: $V_{CE} = 16\text{ V}$, duty cycle: 2 min on, 2 min off, $T_{amb} = 25\text{ }^{\circ}\text{C}$	1000 h (15 000 cycles)	3 x 77 pcs - 0 pcs

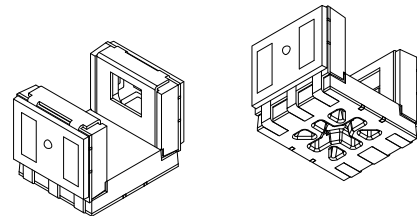
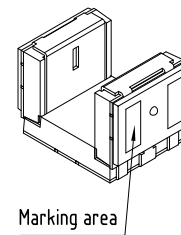
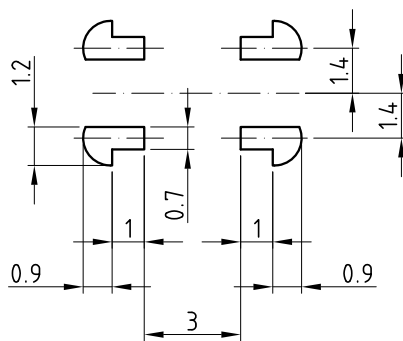
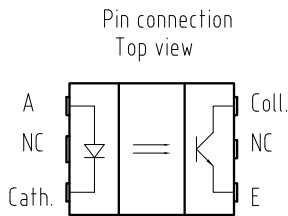
RELIABILITY TESTS IN REFERENCE TO ENHANCED TEMPERATURE RELEASE ACC. AEC-Q101			
TEST	CONDITION	DURATION	LOT SIZE - REJECTS
High temperature storage	$T_{stg} (max.) = 125\text{ }^{\circ}\text{C}$	1000 h	1 x 50 pcs - 0 pcs
Temperature cycling	$-40\text{ }^{\circ}\text{C}/+150\text{ }^{\circ}\text{C}$	1000 x	1 x 77 pcs - 0 pcs
Power temperature cycle	$-25\text{ }^{\circ}\text{C}/+85\text{ }^{\circ}\text{C}$, $I_F = 50\text{ mA}$, $V_{CE} = 16\text{ V}$, 2 min. on, 2 min. off	1000 h (15 000 cycles)	1 x 77 pcs - 0 pcs



PACKAGE DIMENSIONS in millimeters



Proposed solderpad design



Drawing-No.: 6.541-5062.01-4

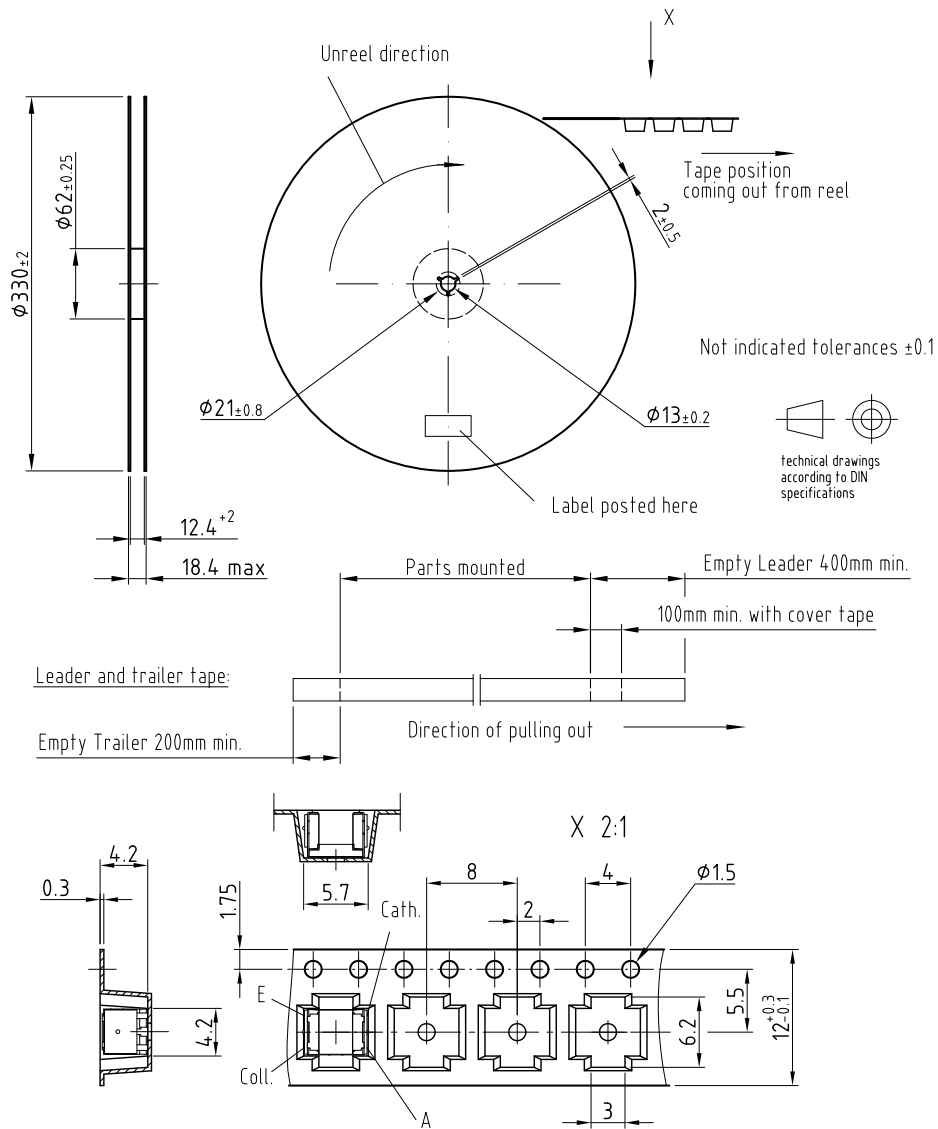
Issue: 6; 14.05.07

19591



PACKAGE DIMENSIONS in millimeters

Volume/reel = 2000 pcs



Drawing-No.: 9.800-5092.02-4

Issue: 1; 14.05.07

20601

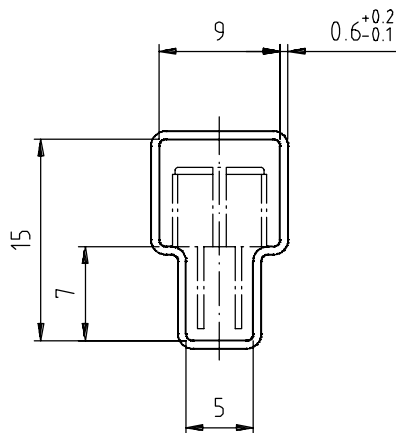
Packaging and Ordering Information

PART NUMBER	MOQ ⁽¹⁾	PCS PER TUBE	TUBE SPEC. (FIGURE)	CONSTITUENTS (FORMS)
CNY70	4000	80	1	28
TCPT1300X01	2000	Reel	(2)	29
TCRT1000	1000	Bulk	-	26
TCRT1010	1000	Bulk	-	26
TCRT5000	4500	50	2	27
TCRT5000L	2400	48	3	27
TCST1030	5200	65	5	24
TCST1030L	2600	65	6	24
TCST1103	1020	85	4	24
TCST1202	1020	85	4	24
TCST1230	4800	60	7	24
TCST1300	1020	85	4	24
TCST2103	1020	85	4	24
TCST2202	1020	85	4	24
TCST2300	1020	85	4	24
TCST5250	4860	30	8	24
TCUT1300X01	2000	Reel	(2)	29
TCZT8020-PAER	2500	Bulk	-	22

Notes

- (1) MOQ: minimum order quantity
- (2) Please refer to datasheets

TUBE SPECIFICATION FIGURES



With rubber stopper

Tolerance: ±0.5mm

Length: 575±1mm

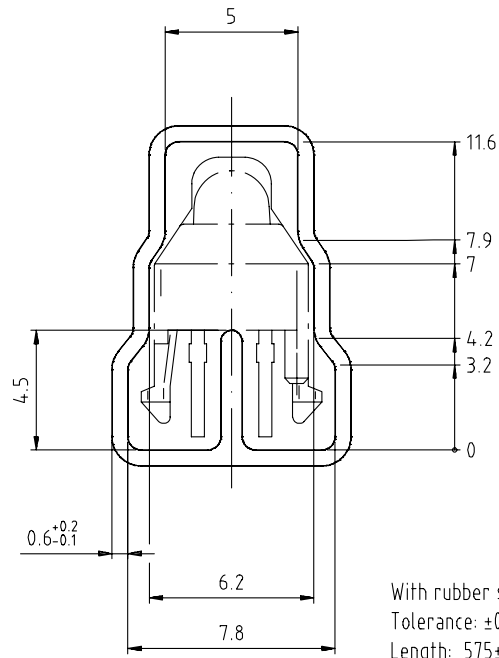
Drawing-No.: 9.700-5097.01-4
Issue: 1; 25.02.00

15198

Fig. 1

Packaging and Ordering Information

Vishay Semiconductors Packaging and Ordering Information

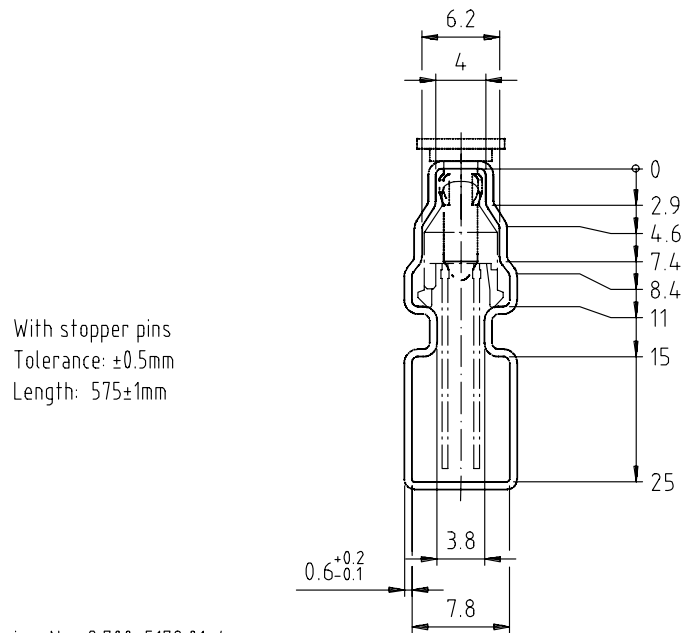


Drawing-No.: 9.700-5139.01-4
Issue: 1; 10.05.00

Drawing refers to following types: TCRT 5000

15210

Fig. 2

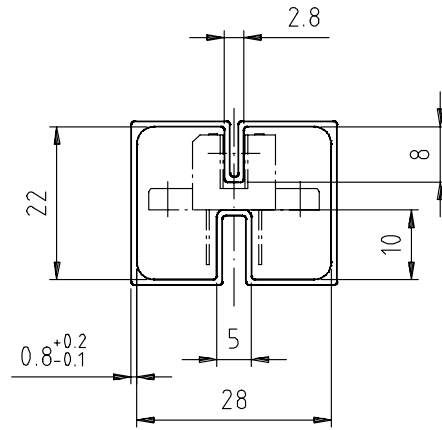


With stopper pins
Tolerance: $\pm 0.5\text{mm}$
Length: $575 \pm 1\text{mm}$

Drawing-No.: 9.700-5178.01-4
Issue: 1; 25.02.00

15201

Fig. 3

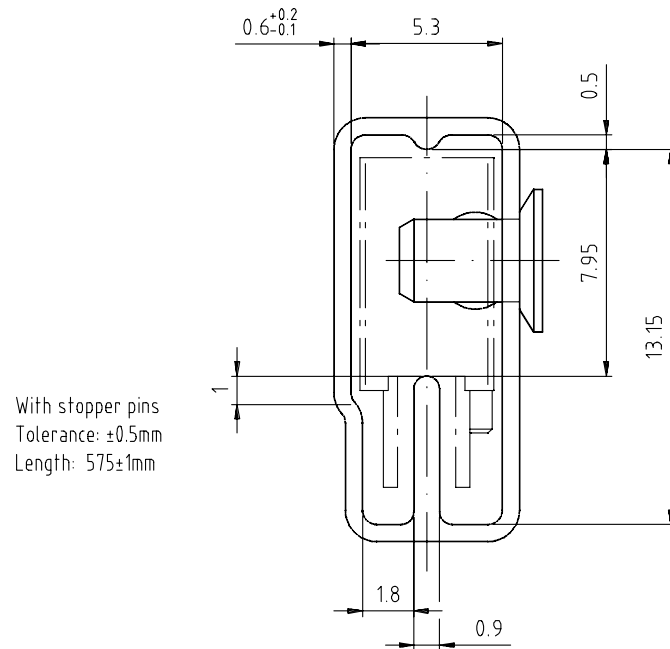


With rubber stopper
Tolerance: ±0.5mm
Length: 575±1mm

Drawing-No.: 9.700-5100.01-4
Issue: 1; 25.02.00

15199

Fig. 4

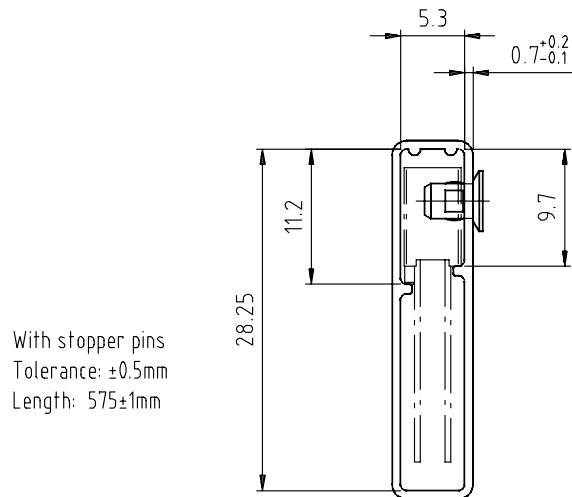


With stopper pins
Tolerance: ±0.5mm
Length: 575±1mm

Drawing-No.: 9.700-5140.01-4
Issue: 1; 25.02.00

15202

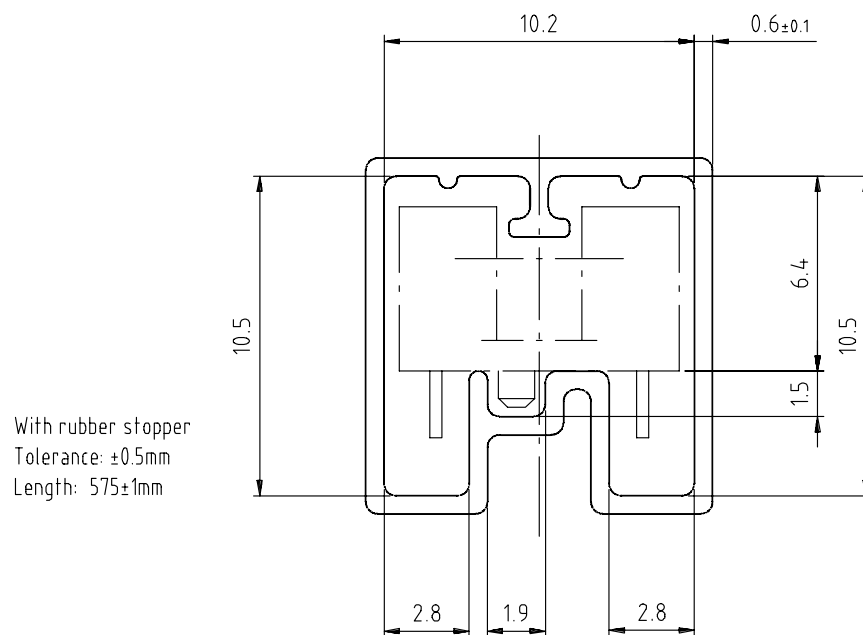
Fig. 5



Drawing-No.: 9.700-5205.01-4
Issue: 1; 25.02.00

15196

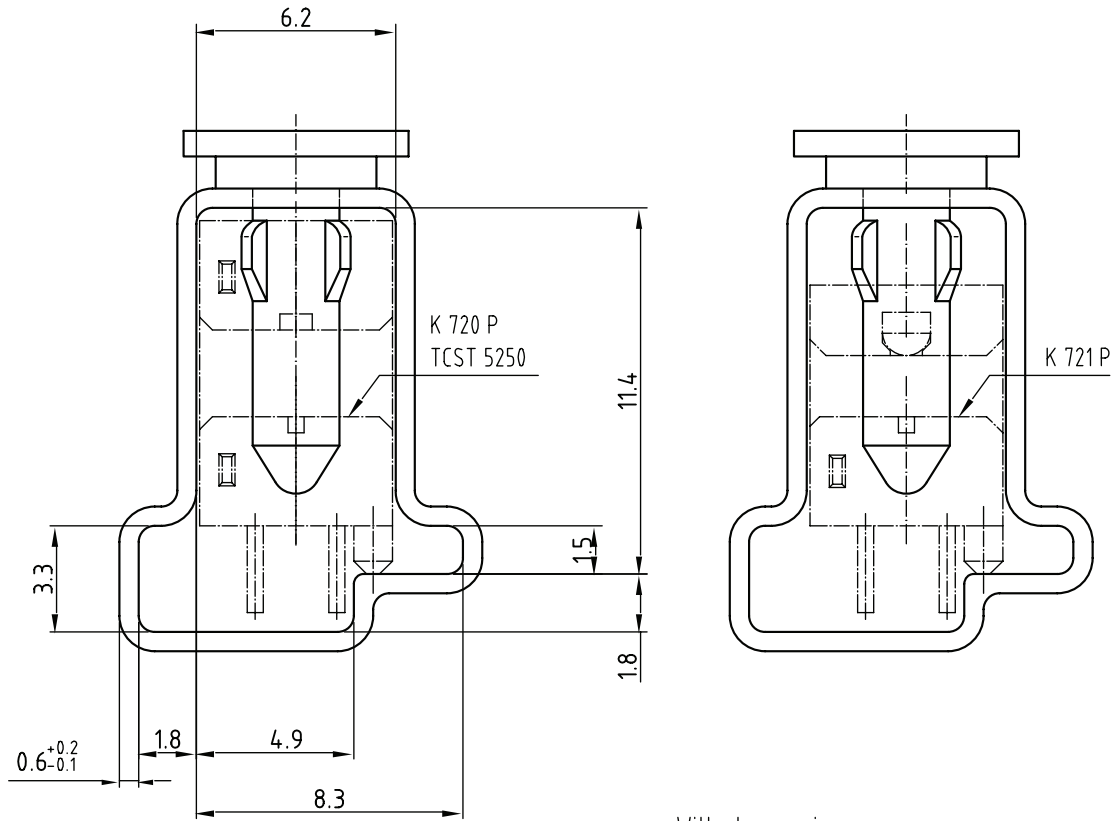
Fig. 6



Drawing-No.: 9.700-5245.01-4
Issue: 1; 25.02.00

15195

Fig. 7



Drawing-No.: 9.700-5222.01-4
 Issue: 2, 19.11.04
 20257

With stopper pins
 Tolerance: ± 0.5 mm
 Length: 450 ± 1 mm
 All dimensions in mm

Fig. 8



Disclaimer

ALL PRODUCT, PRODUCT SPECIFICATIONS AND DATA ARE SUBJECT TO CHANGE WITHOUT NOTICE TO IMPROVE RELIABILITY, FUNCTION OR DESIGN OR OTHERWISE.

Vishay Intertechnology, Inc., its affiliates, agents, and employees, and all persons acting on its or their behalf (collectively, "Vishay"), disclaim any and all liability for any errors, inaccuracies or incompleteness contained in any datasheet or in any other disclosure relating to any product.

Vishay makes no warranty, representation or guarantee regarding the suitability of the products for any particular purpose or the continuing production of any product. To the maximum extent permitted by applicable law, Vishay disclaims (i) any and all liability arising out of the application or use of any product, (ii) any and all liability, including without limitation special, consequential or incidental damages, and (iii) any and all implied warranties, including warranties of fitness for particular purpose, non-infringement and merchantability.

Statements regarding the suitability of products for certain types of applications are based on Vishay's knowledge of typical requirements that are often placed on Vishay products in generic applications. Such statements are not binding statements about the suitability of products for a particular application. It is the customer's responsibility to validate that a particular product with the properties described in the product specification is suitable for use in a particular application. Parameters provided in datasheets and/or specifications may vary in different applications and performance may vary over time. All operating parameters, including typical parameters, must be validated for each customer application by the customer's technical experts. Product specifications do not expand or otherwise modify Vishay's terms and conditions of purchase, including but not limited to the warranty expressed therein.

Except as expressly indicated in writing, Vishay products are not designed for use in medical, life-saving, or life-sustaining applications or for any other application in which the failure of the Vishay product could result in personal injury or death. Customers using or selling Vishay products not expressly indicated for use in such applications do so at their own risk. Please contact authorized Vishay personnel to obtain written terms and conditions regarding products designed for such applications.

No license, express or implied, by estoppel or otherwise, to any intellectual property rights is granted by this document or by any conduct of Vishay. Product names and markings noted herein may be trademarks of their respective owners.

Material Category Policy

Vishay Intertechnology, Inc. hereby certifies that all its products that are identified as RoHS-Compliant fulfill the definitions and restrictions defined under Directive 2011/65/EU of The European Parliament and of the Council of June 8, 2011 on the restriction of the use of certain hazardous substances in electrical and electronic equipment (EEE) - recast, unless otherwise specified as non-compliant.

Please note that some Vishay documentation may still make reference to RoHS Directive 2002/95/EC. We confirm that all the products identified as being compliant to Directive 2002/95/EC conform to Directive 2011/65/EU.

Vishay Intertechnology, Inc. hereby certifies that all its products that are identified as Halogen-Free follow Halogen-Free requirements as per JEDEC JS709A standards. Please note that some Vishay documentation may still make reference to the IEC 61 249-2-21 definition. We confirm that all the products identified as being compliant to IEC 61 249-2-21 conform to JEDEC JS709A standards.