



TCS230 Color Sensor Module

User's Guide

Table of Contents

Chapter 1. Overview	1
1.1 Overview	1
1.2 Features	1
1.3 Applications.....	1
1.4 Pin Descriptions.....	2
Chapter 2. Hardware Detail	3
2.1 Absolute Maximum Ratings	3
2.2 Operating Ratings	3
2.3 Color Characteristics.....	3
2.4 Interface Characteristics	3
2.4.1 Digital Interface Characteristics.....	3
2.4.2 Analog Interface Characteristics	5
Chapter 3. Application Notes	7
3.1 Principle of How TCS230 Identifies Different Colors	7
3.2 White Balance.....	7
3.3 Test Mode and Normal Mode	7
Chapter 4. Mechanical Drawing.....	8
Chapter 5. Contact Us	9

TCS230 Color Sensor Module

NOTES:

Product Version : Ver 1.0

Document Version : Ver 1.0

Chapter 1. Overview

1.1 Overview

Welcome to use TCS230 Color Sensor Module by Sure Electronics. Employing TCS230 of TAOS as the signal acquisition chip, this module is quite available in color detection and sorting operations. It is also useful by providing both digital and analog signal outputs.

1.2 Features

DC: 3.3V to 5V

Fast response time

Supplied 6mm lens with an IR filters

Analog & digital output

 Analog: RGB voltage signal linear output

 Digital: UART half duplex, SPI slave mode

DIP-like packaging, which facilitates system integration

FIGURE 1-1 OVERVIEW

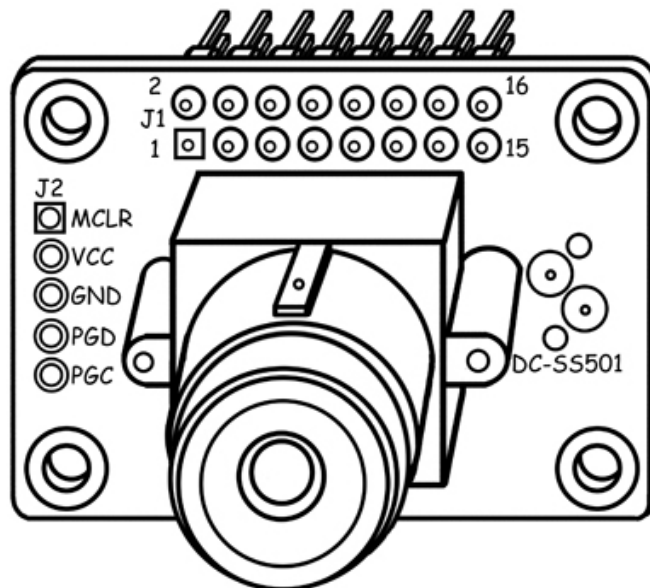

1.3 Applications

Portable color identification system

Color monitor to color printing

Process control to printed materials

LED testing

Other occasions requiring color detection and sorting operations

TCS230 Color Sensor Module

1.4 Pin Descriptions

FIGURE 1-2 BACK VIEW

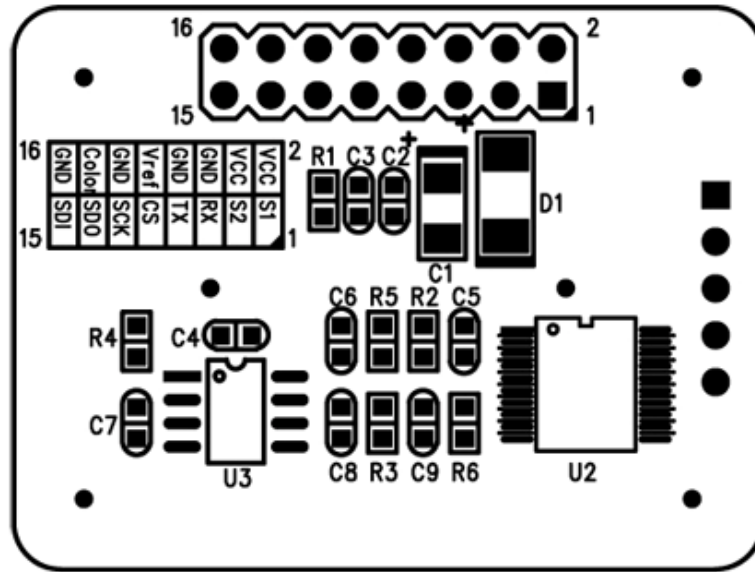

TABLE 1-1 PIN DESCRIPTION

Label	Pin	Function	Label	Pin	Function
S1	1	Analog output control terminal 1	VCC	2	Power input
S2	3	Analog output control terminal 2	VCC	4	Power input
RXD	5	UART Received Data	GND	6	Ground
TXD	7	UART Transmitted Data	GND	8	Ground
/CS	9	SPI enable.	Vref	10	Reference voltage output
SCK	11	SPI clock	GND	12	Ground
SDO	13	SPI data output	Vcolor	14	Color voltage output
SDI	15	SPI data input	GND	16	Ground

Chapter 2. Hardware Detail

2.1 Absolute Maximum Ratings

Storage temperature: -20 to 85 °C
 Storage humidity range: 0 to 90 % RH
 Supply voltage: DC 5.5 V

2.2 Operating Ratings

Temperature operating range: -15 to 60 °C
 Humidity operating range: 0 to 85% RH
 Supply voltage: DC 3.3V to 5V

2.3 Color Characteristics

TABLE 2-1 COLOR CHARACTERISTICS

Parameter	Min.	Typ.	Max.	Unit.
Color measuring range	350	/	750	nm
Luminance range	100	/	/	lux
Response time	/	500	/	ms

Note: You can refer to TCS230 datasheet for more information about Color Characteristics.

2.4 Interface Characteristics

2.4.1 Digital Interface Characteristics

D-1. Digital Interface I/O Electrical Characteristics : Vin=3.3V to 5.0V

TABLE 2-2 DIGITAL INTERFACE CHARACTERISTICS

Parameter	Min.	Typ.	Max.	Units
Input low voltage	/	/	0.2Vin	V
Input high voltage	0.8Vin	/	/	V
Output low voltage	/	/	0.6	V
Output high voltage	Vin – 0.9	/	/	V

D-2. UART Interface:

DC-SS501 has an UART interface and is able to communicate with any host that has an UART interface.

① UART Properties:

Baud rate: 9600bps
 Start bit: 1bit
 Data bit: 8bits
 Parity bit: 0bit
 Stop bit: 1bit

② UART Command:

TCS230 Color Sensor Module

TABLE 2-3 UART COMMAND

Command	Function
wb	Start white balance
tm	Enter test mode
nm	Enter normal mode
r	Access current Red value
g	Access current Green value
b	Access current Blue value

Note:

1. All UART commands shall start with "\$sure" and followed by a space (0x20) and end with enter (0x0d, 0x0a).
2. All UART commands shall be expressed in ASCII.
3. All UART commands are not case-sensitive.

③ Examples:

1. Start white balance

```
$SURE WB  
Start white balance...
```

```
White balance done!
```

2. Access current Red value

```
$SURE R  
Red=00015
```

3. Enter test mode

```
$SURE TM  
Test mode setting done!
```

4. Enter normal mode

```
$SURE NM  
Normal mode setting done!
```

5. Prompt of bad commands

```
sure  
Bad command!
```

Unrecognized guide word, returns "Bad command!"

```
$sure su  
Unknown command!
```

Unknown command!

Incorrect command returns "Unknown command!"

D-3.SPI Interface:

DC-SS501 has a SPI interface (Slave Mode), which can be used conveniently for the communication with any host that has SPI interface.

- ① SPI Command:

TABLE 2-4 SPI COMMAND

Command	Function
0x c0	Return current Red value (0~255)
0x c1	Return current Green value (0~255)
0x c2	Return current Blue value (0~225)

② Examples:

TABLE 2-5 EXAMPLES

Received command	Return value	Descriptions
0xc0	0xF5	The current Red value is 245
0xc1	0x10	The current Green value is 16
0xc2	0x3D	The current Blue value is 61

③ SPI Timing:

FIGURE 2-1 SPI TIMING

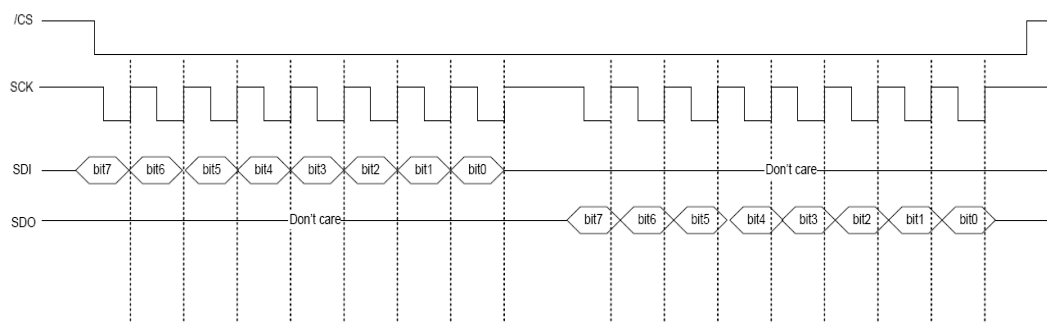

Note:

1. The SCK frequency of SPI interface shall be in a range from 3 kHz to 2MHz.
2. /CS is in low level only when SPI interface communication is in progress and shall be in high level in any other situations.
3. The interval of two successive commands shall be greater than 0.2s.
4. SPI interface in this version doesn't have the function of white balance. UART interface must be used.
5. SPI in this version is not available in the test mode.

2.4.2 Analog Interface Characteristics

DC-SS501 is integrated with an analog output set, which can work only in the normal mode.

A-1. Analog Output Selection Control

The analog output of DC-SS501 controls the type of Color output via two selection terminals:

TABLE 2-6 SELECTION TERMINALS

S1	S2	Color output
0	0	Red
0	1	Green
1	0	Blue
1	1	Off

A-2. Color Output Typical Characteristics

TCS230 Color Sensor Module

TABLE 2-7 COLOR OUTPUT LOOK-UP TABLE

Color (0-255)	Color Output (V) (Vref=3.07V)	Color Output (V) (Vref=4.95V)
0	0.01	0.02
20	0.24	0.38
40	0.48	0.76
60	0.71	1.14
80	0.98	1.52
100	1.21	1.91
120	1.44	2.28
140	1.68	2.66
160	1.92	3.04
180	2.16	3.42
200	2.42	3.79
220	2.64	4.18
240	2.87	4.56
255	3.04	4.84

Chapter 3. Application Notes

3.1 Principle of How TCS230 Identifies Different Colors

According to the induction principle of the three primary colors which create various other colors in nature, once the value of the three primary colors is confirmed, the color of the tested object is known. When a color filter is selected, TCS230 just allows the corresponding color to pass. E.g. when the red filter is selected, only red light can pass through it and the red light intensity can be obtained. So is the green and blue filter. Knowing the value of RGB helps people gain the color of the light which is projected onto TCS230 since each color corresponds to only one value of RGB.

3.2 White Balance

Simply speaking, White Balance is to tell the system what white is. In theory, white is a mixture of red, green and blue which are equivalent. Actually, the three primary colors are not in the absolutely equivalent value and TCS230 senses differently to the three basic colors so that RGB outputs are not equal. Hence white balance should be adjusted before test to enable TCS230 get the equivalent value of RGB of white which will be tested. If TCS230 is used for the first or to identify the restart of the module and light replacement, white balance should be adjusted for the follow-up color identification.

3.3 Test Mode and Normal Mode

Test mode and normal mode are set to meet different customers' need. In test mode, it will be slow that UART interface outputs the value of RGB frequency outputted by TCS230 (The specific meaning of RGB frequency can be read in TCS230 Data Sheet). In addition, neither SPI nor analog interface is available. In normal mode, UART interface outputs the value of RGB (0~255) which is calibrated by White Balance and both SPI interface and analog interface works.

Chapter 4. Mechanical Drawing

FIGURE 4-1 MECHANICAL DRAWING

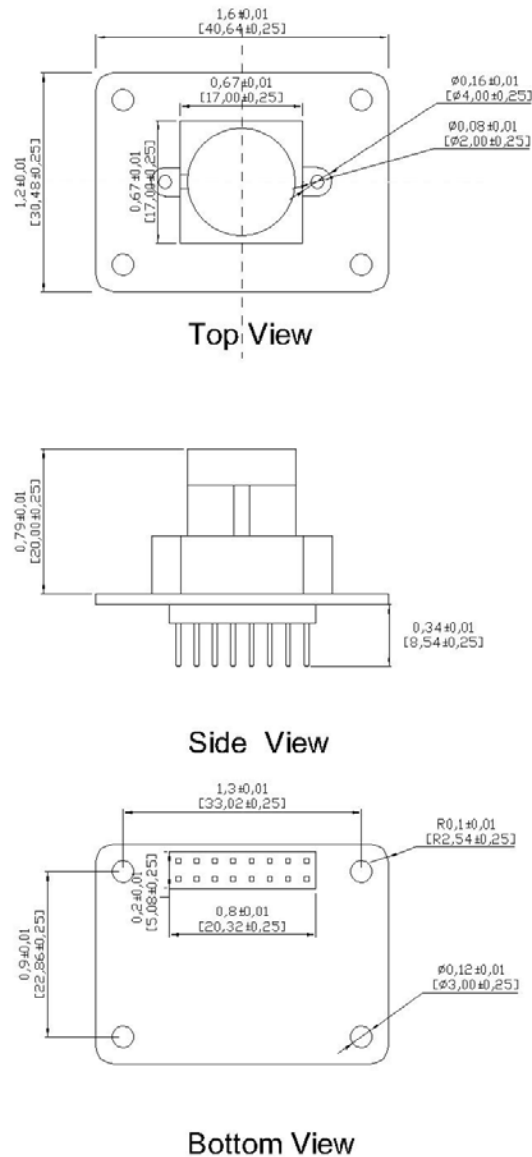

UNIT: INCH
[MM]

Chapter 5. Contact Us

Sure Electronics Co., Ltd.

5F, Zone A,
Qinhuai Technology Innovation Center
105-2 DaMing Rd (ZIP:210022)
Nanjing
P.R.China

Tel: +86-13601408832 (For technical questions only)
+86-25-66606340 (English service, from GMT1-10AM)
Fax: +86-25- 66606341-866
Website: www.sure-electronics.com
www.sure-electronics.net