

TFT LCD Specification

Model Name: TD022SREC2

Customer Signature
Date

This technical specification is subjected to change without notice

Table of Contents

NO.	Item	Page
	Cover Sheet	1
	Table of Contents	2
	Record of Reversion	3
1	Features	4
2	General Specification	4
3	Input / Output Terminals	5
4	Absolute Maximum Ratings	7
5	Electrical Characteristics	7
6	Timing Chart	10
7	Optical Characteristics	14
8	Reliability	18
9	Handling Cautions	19
10	Mechanical Drawing	20
11	Packing Drawing	22



Record of Reversion

Rev	Issued Date	Description
1.0	Aug 25, 2005	New Issue

1. FEATURES

The 2.2"(5.6 cm) LCD module is an trans-flective active matrix color TFT LCD module. LTPS (Low Temperature Poly Silicon) TFT technology is used and vertical drivers are built on the panel.

2. GENERAL SPECIFICATIONS

Item	Description	Unit
Display Size (Diagonal)	2.2 (5.6)	
Display Type	Trans-flective	
Active Area (HxV)	33.84 x 45.12	mm
Number of Dots (HxV)	240 x RGB x 320	dot
Dot Pitch (HxV)	0.047 x 0.141	mm
Color Arrangement	RGB Stripe	
Color Numbers	262144 (bit: R=6, G=6, B=6)	
Outline Dimension (HxVxT)*	41.3 x 58.15 x 3.41	mm
Weight	15.35	g

* Exclude FPC and protrusions.

3. INPUT/OUTPUT TERMINALS

Recommend connector: Molex 500027-4041

No.	Pin Name	I/O	Description	Note												
Input Video signal																
1	DE	I	Data Enable													
2	HSYNC	I	Horizontal SYNC signal													
3	VSYNC	I	Vertical SYNC signal													
4	CLK	I	Clock signal													
5	RI[5:0]	I	Input RI5 ~ RI0													
6	GI[5:0]	I	Input GI5 ~ GI0													
7	BI[5:0]	I	Input BI5 ~ BI0													
8	SD	I	Shutdown L : Normal H : Shutdown													
Function Pin Control																
1	FCS	I	Function pin control signal enable bit (0x06) L: External I/O H: Internal Register													
2	RL	I	Shift direction (Right/Left) H: D1→D240 L: D240→D1													
3	TB	I	Shift direction (Top/Bottom) H: Top→Bottom L: Bottom→Top													
4	CM	I	Full color or partial color mode setup L: 262K color H: 8 color partial													
5	Resolution0	I	Resolution mode select <table border="1" style="display: inline-table; vertical-align: middle;"> <thead> <tr> <th>R1</th> <th>R0</th> <th>Resolution</th> </tr> </thead> <tbody> <tr> <td>0</td> <td>0</td> <td>240 x RGB x 320</td> </tr> <tr> <td>0</td> <td>1</td> <td>176 x RGB x 220</td> </tr> <tr> <td>1</td> <td>x</td> <td>128 x RGB x 160</td> </tr> </tbody> </table>	R1	R0	Resolution	0	0	240 x RGB x 320	0	1	176 x RGB x 220	1	x	128 x RGB x 160	
R1	R0	Resolution														
0	0	240 x RGB x 320														
0	1	176 x RGB x 220														
1	x	128 x RGB x 160														
6	Resolution1	I														
7	INVSEL	I	Invert-mode select L: line inversion H: Frame inversion													
8	MSP1	I	STV1 signal output enable pin L: Enable (on) H: Disable (off)													
9	MSP2	I	STV2 signal output enable pin L :Enable (on) H: Disable(off)													
Driving Signal Output																
1	CKH1	O	Horizontal clock 1 output													
2	CKH2	O	Horizontal clock 2 output													
3	CKH3	O	Horizontal clock 3 output													

4	STV1	O	Vertical start output1	
5	STV2	O	Vertical start output2	
5	CKV1	O	Vertical clock output	
6	CKV2	O	Vertical clock output	
7	ENBV	O	Vertical scanner enable pulse	
8	CSV	O	Vertical scan direction	
9	D1-240	O	Data source output	
10	VCOM	O	Common voltage	
Serial INTERFACE(SPI)				
1	LOAD	I	Load input for serial bus	
2	DATA	I/O	Data input for serial bus	
3	SCLK	I	Clock input for serial bus	
Misc.				
1	RESET	I	System reset	
2	VCOMH	I	Capacitor for COM voltage	
3	VCOML	I	Capacitor for COM voltage	
Image Sticking				
1	ISVi	I	+4.2V input pin for image sticking	
2	ISC	O	Connect Big Cap for image sticking	
3	IV6P	O	-6.5V output voltage for image sticking	
DC/DC controller				
1	Vref		Reference Voltage	
2	C1A		Capacitor for Vout2 , booster × 2	
3	C1B		Capacitor for Vout2 , booster × 2	
4	P1O		VCI × 2	
5	Vout2		+4.2V voltage output	
6	C2A		Capacitor for Vout3 , booster × 2	
7	C2B		Capacitor for Vout3 , booster × 2	
8	P2O		P1O × 2	
9	Vout3		+10V voltage output	
10	C3A		Capacitor for Vout3 , booster × 2	
11	C3B		Capacitor for Vout3 , booster × 2	
12	Vout4		-5.5V voltage output	
Power Supply				
1	VDD	—	Logic Power Supply (2.775V or 1.8V)	
2	VDD2	—	Power Supply 2 (4.2V)	
3	VDD3		Power Supply 3 (10V)	

4	VDC		DC/DC control Power Supply (2.775V)	
5	VSS		GND	

note : Vout2=VDD2 , Vout3=VDD3 , Vout4 connection to panel VVEE

4. ABSOLUTE MAXIMUM RATINGS

Item	Symbol	Min	MAX	Unit	Remark
DC/DC Input voltage	VDC	-0.3	VDC+0.3	V	
Logic input Voltage	VDD	-0.3	VDD1+0.3	V	
Back Light Forward Current	I _F	-	15	mA	
Operating temperature	Topr	-20	+60	°C	
Storage temperature	Tstg	-30	+70	°C	Note

(Ta=+25°C, VSS=0V)

Note: Both of these two items are for module temperature, not IC spec.

5. ELECTRICAL CHARACTERISTICS

Allowable Operation condition (Ta=25°C , VSS=0)

Parameter	Symbol	Conditions	Ratings			Unit
			MIN	TYP	MAX	
Supply Voltage (Logic)	VDD		1.7	1.875 / 2.775	3.0	V
Supply Voltage (DC/DC)	VDC		2.6	2.775	3.0	V
Logic high-level input	Vih		0.7VDD	—	VDD	V
Logic low-level input	Vil		0	—	0.3VDD	V
Input Signal Voltage	DE signal	DE	1.7	1.875	3.0	V
	H_{SYNC} V_{SYNC} signals	HS VS	1.7	1.875	3.0	V
	Data Signals	R,G, B	1.7	1.875	3.0	V
	Clock signal	CLK	1.7	1.875	3.0	V
	Misc. signals	Serial I/F	1.7	1.875	3.0	V

Power consumption	Normal mode (full screen@60Hz, Tizu patten)	Pwr	With loading	—	11.73	17.834	mW
	Power Save Mode (64lines@30 Hz, Tizu patten)			—	2.36	4.227	mW
	Sleep Mode			--	17.96	28.04	uW
Operating Current in Normal Mode (VDDIO)		$I_{DD-Normal}$	Black pattern	--	0.5	0.7	mA
Operating Current in Normal Mode (VCI)		$I_{CI-Normal}$	Black pattern	--	4.2	5	mA

< Power sequence >

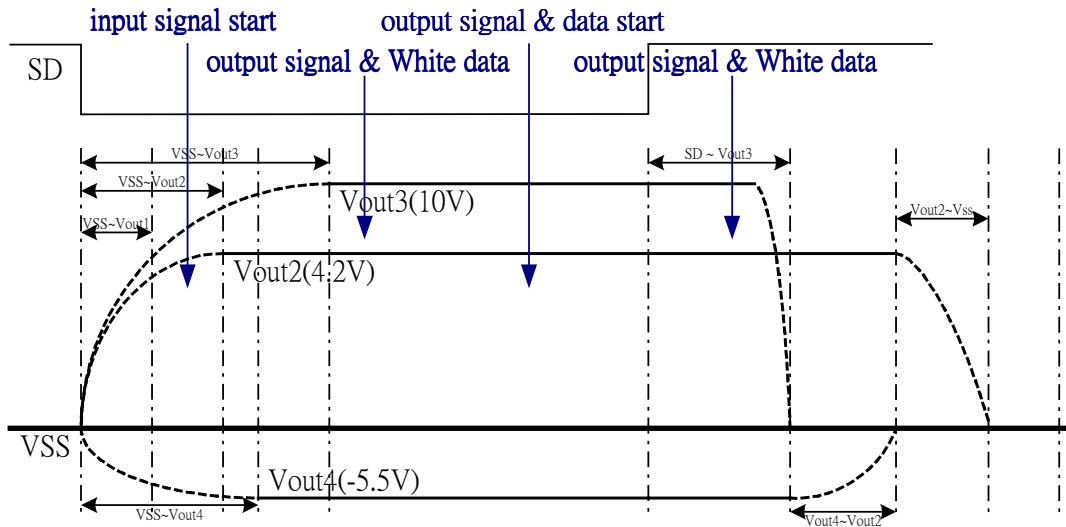

Power ON :VDD-> input signal -> 4.2V -> -5.5V -> 10V -> White data & signal output -> data output
 Power OFF :White data & signal output -> 10V -> -5.5V -> 4.2V -> VDD

5.1 Driving TFT LCD panel block diagram

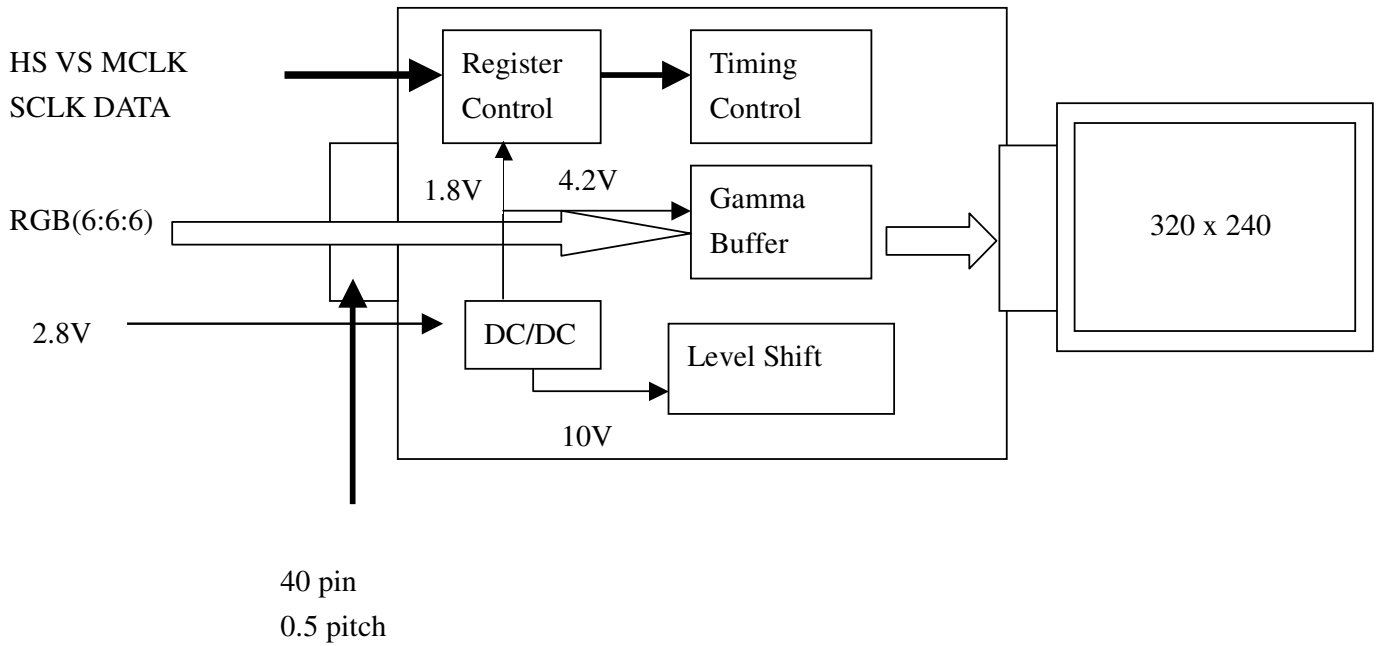

5.2 Driving Backlight

Ta=25°C

Item	Symbol	MIN	TYP	MAX	Unit	Remark
Forward Current	I _F	--	15	--	mA	Note 5-2
Forward Current Voltage	V _F	--	14.4	--	V	
Backlight Power Consumption	W _{BL}	--	216	--	mW	

Note 5-2: LEDx4

6. TIMING CHART

6.1 Horizontal Read/ Write Timing

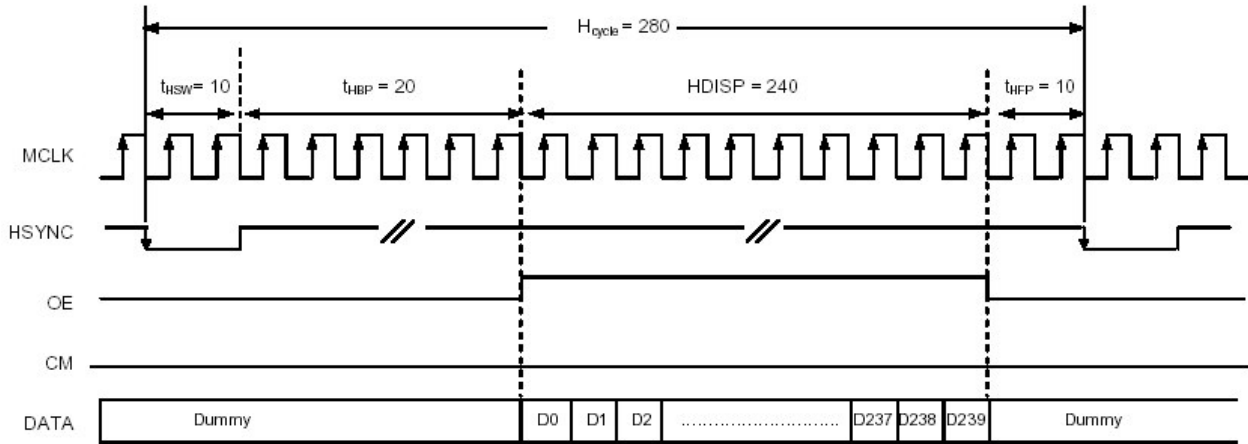

6.2 Vertical Read/ Write Timing

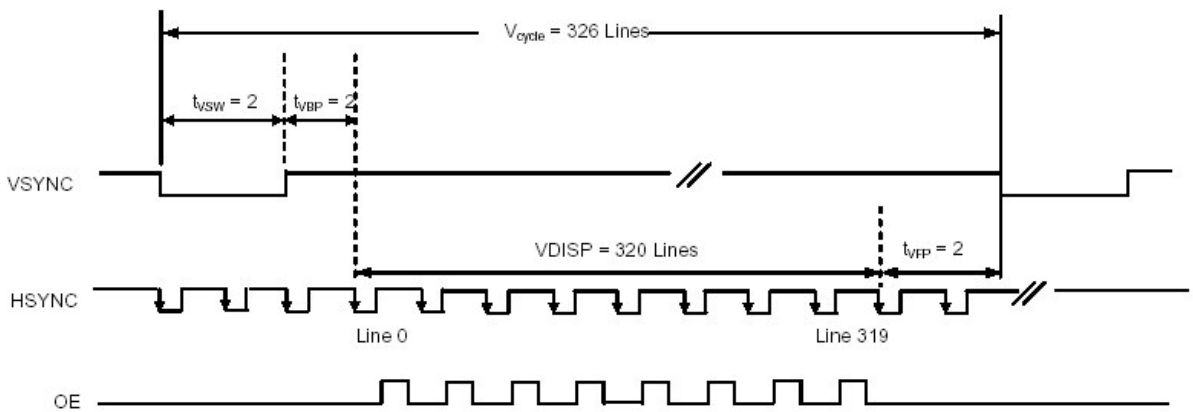

6.3 Pixel clock Timing

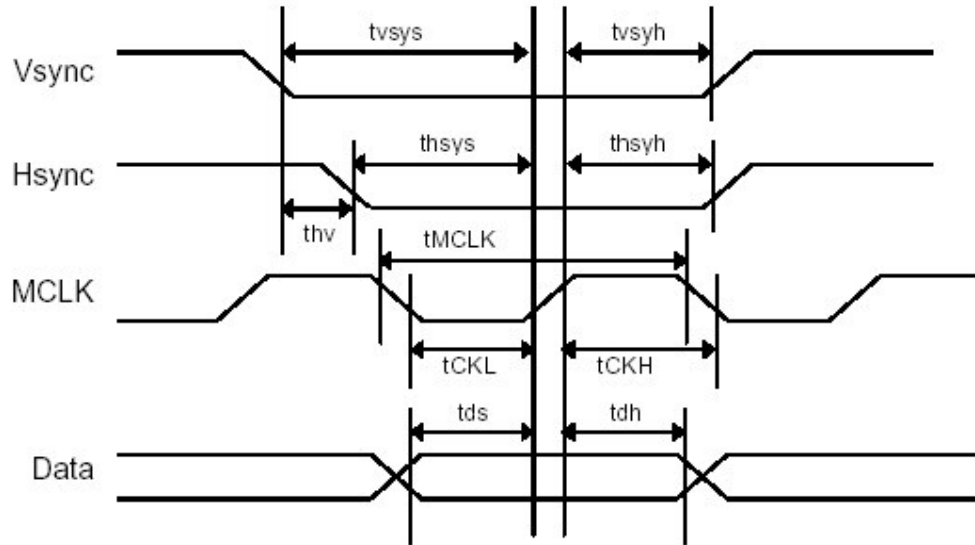

6.4 Power Save Mode

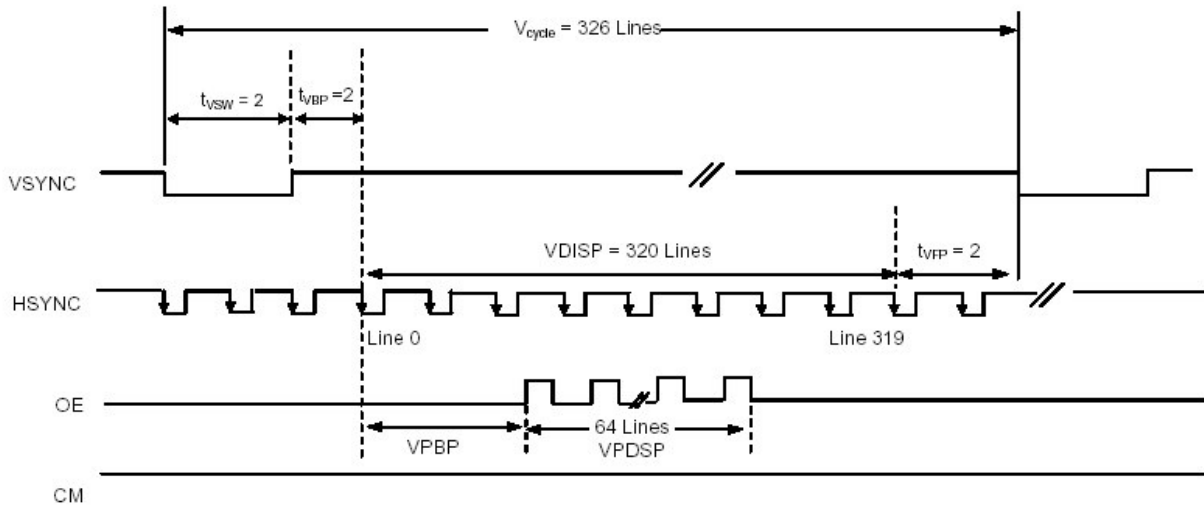

6.5 262K colors Mode -----> 8 colors Mode

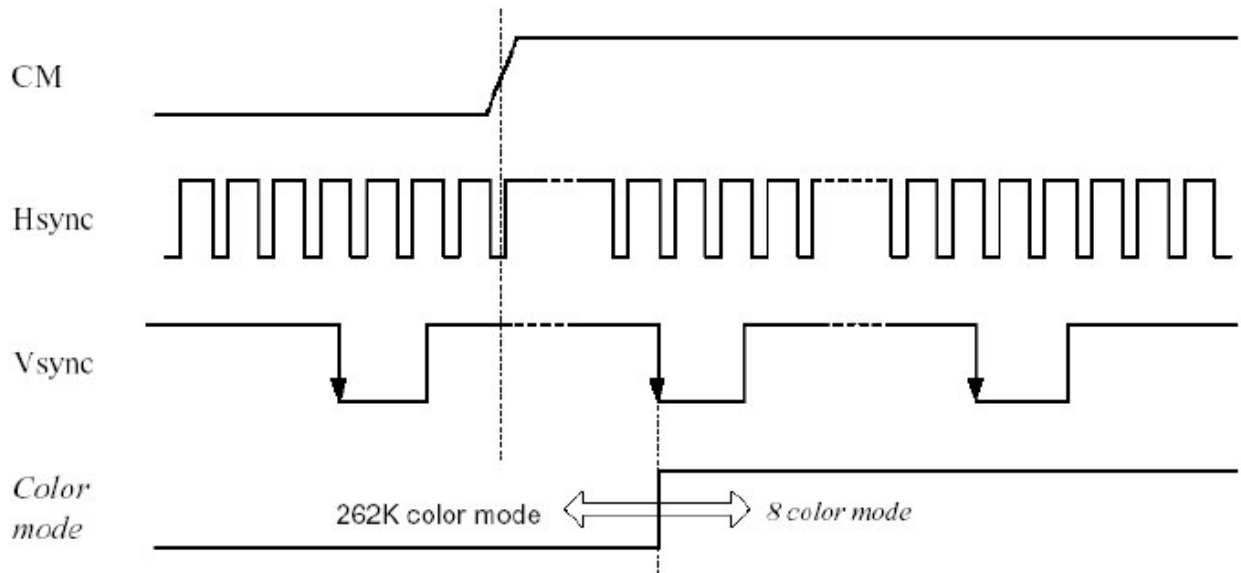

6.6 8 colors Mode-----> 262K colors Mode

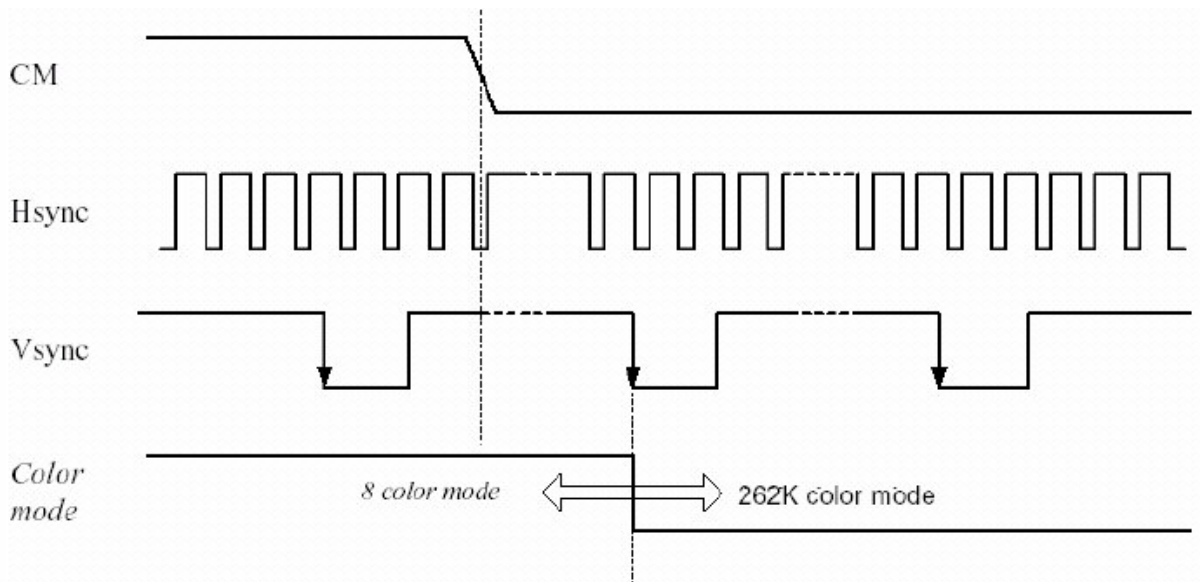

6.7 Display Scan Direction

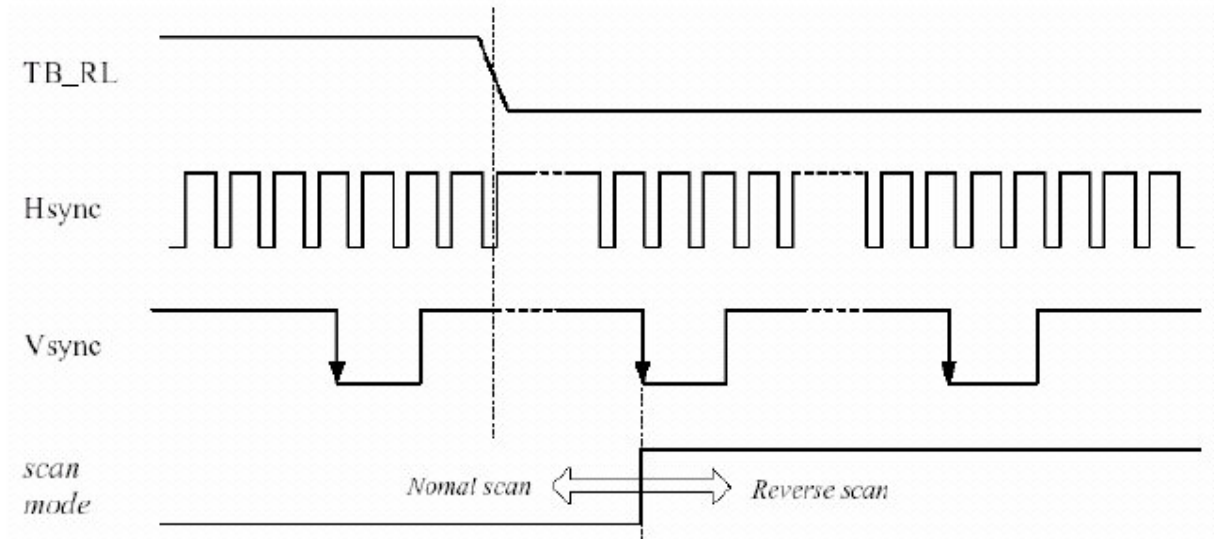

7. OPTICAL CHARACTERISTICS

7.1. Transmissive Mode (T = 25 deg C, $\Theta=0^\circ$, Backlight ON)

Item	Symbol	Condition	MIN	TYP	MAX	Unit	Remarks	
Viewing Angles	ΘR	CR \geq 10	30	45	60	Degree	Note 7-1	
	ΘL		45	55	65			
	ΘU		35	45	55			
	ΘD		50	65	80			
Contrast Ratio	CR	$\Theta=0^\circ$	145	196	--	--	Note 7-2	
Luminance	L	$\Theta=0^\circ$	137	197	--	cd/m ²	Note 7-3	
Color Chromaticity	White	$\Theta=0^\circ$	u	0.175	0.200	0.227	--	Note 7-4
			v	0.440	0.475	0.493		

7.2. Reflective Mode (T = 25 deg C, $\Theta=0^\circ$, Back light off)

Item	Symbol	Condition	MIN	TYP	MAX	Unit	Remarks	
Viewing Angles	CR1	$\Theta=15^\circ$	5.5	8	-	-	Note 7-1(system A)	
	CR2	$\Theta=25^\circ$	4.5	7	-			
	CR3	$\Theta=50^\circ$	1.5	3.5	-			
Chromaticity	White	$\Theta=0^\circ$	u	0.181	0.189	0.215	-	Note 7-5
			v	0.451	0.472	0.485		
Response time	T1	25°C, $\Theta=0^\circ$	-	7.5	15	ms	Note7-6	

7.3 Basic Measure Condition

- (1) Ambient Temperature: $T_a=25^{\circ}\text{C}$
- (2) Testing Point: Measure in the display center point and the test angle $\theta=0^{\circ}$
- (3) Measuring System

a. Measure System A

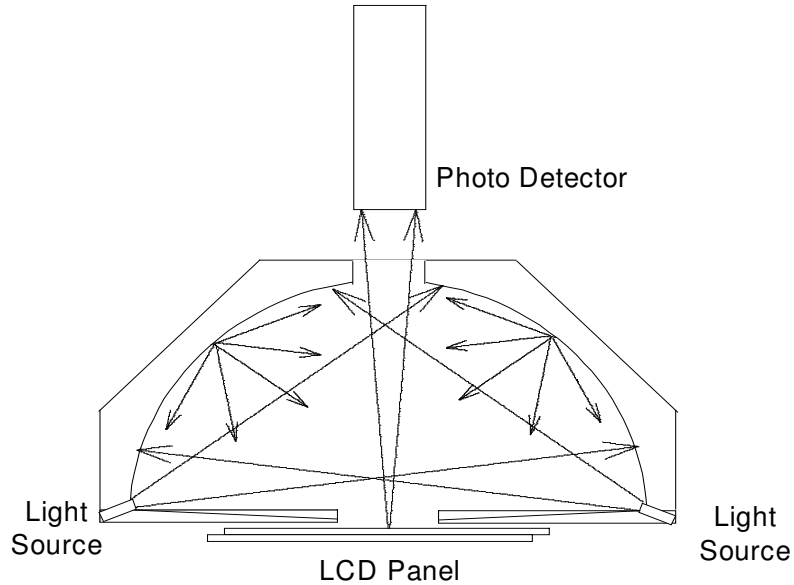

b. Measure System B

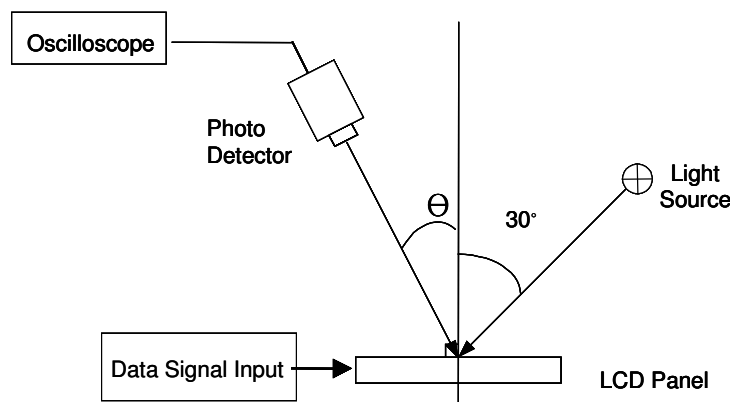

c. Measure System C

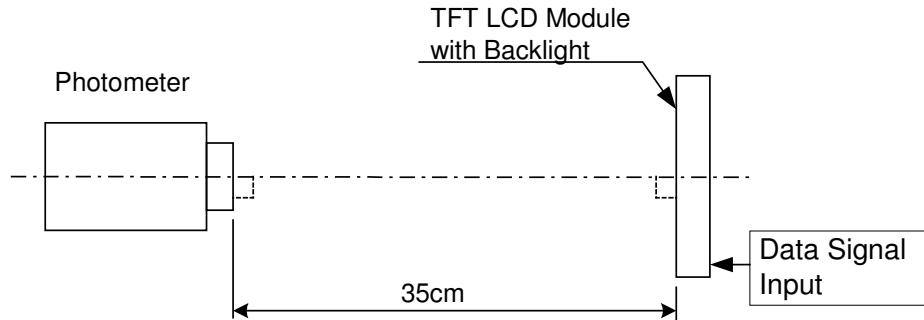

Note 7-1: Viewing angle diagrams:

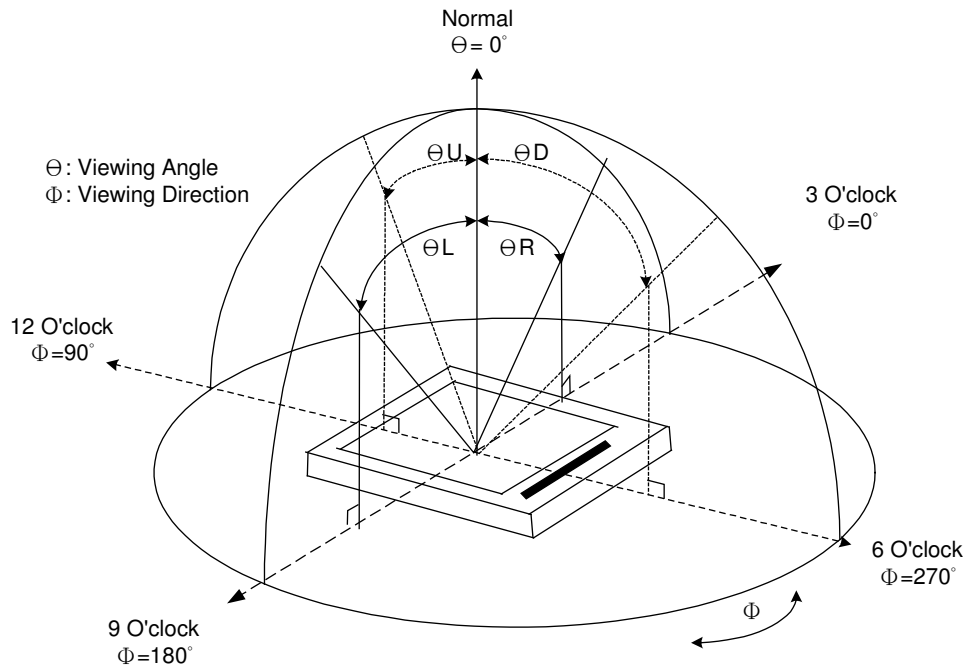

Note 7-2: Contrast Ratio as Backlight On: (Measure System C)

Contrast ratio is measured in optimum common electrode voltage. The signal amplitude

$$CR = \frac{\text{Luminance with white image}}{\text{Luminance with black image}}$$

Note 7-3: Luminance: (Measure System C)

Test Point: Display Center

LED Current $I_F = 15 \text{ mA}$

Note 7-4: White chromaticity as back light on: (Measure System C)

Note 7-5: White chromaticity as back light off: (Measure System A)

Note 7-6: Definition of response time: (Measure System C)

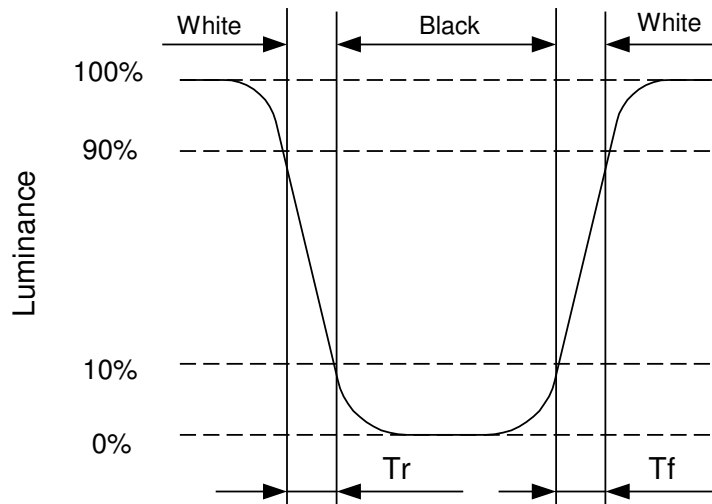

8. REILIABILITY

No	Test Item	Condition
1	High Temperature Operation	Ta=+70°C, 240hrs
2	High Temperature & High Humidity Operation	Ta=+40°C, 95% RH, 240hrs
3	Low Temperature Operation	Ta=-20°C, 240hrs
4	High Temperature Storage (non-operation)	Ta=+80°C, 240hrs
5	Low Temperature Storage (non-operation)	Ta=-30°C, 240hrs
6	Thermal Shock (non-operation)	-40°C ← → 85°C, 27 cycles 45 min 45 min
7	Resistance to Static Electricity Discharge (non-operation)	C=200pF, R=0Ω; Discharge: ±150V 3 times / Terminal
8	Surface Discharge (non-operation)	C=150pF, R=330Ω; Discharge: Air: ±15kV; Contact: ±8kV 5 times / Point; 5 Points / Panel
9	Vibration (non-operation)	Frequency: 10~55Hz; Amplitude: 1.5mm Sweep Time: 11min Test Time: 2 hrs for each direction of X, Y, Z
10	Shock (non-operation)	Acceleration: 100G; Period: 6ms Directions: ±X, ±Y, ±Z; Cycles: Twice

Ta: Ambient Temperature

9. HANDLING CAUTIONS

9.1 ESD (Electrical Static Discharge) Strategy

ESD will cause serious damage of the panel, ESD strategy is very important in handling.

Following items are the recommend ESD strategy

- (1) In handling LCD panel, please wear non-charged material gloves. And the conduction ring connect wrist to the earth and the conducting shoes to the earth is necessary.
- (2) The machine and working table for the panel should have ESD prohibition strategy.
- (3) In handling the panel, ionize flowing decrease the charge in the environment is necessary.
- (4) In the process of assembly the module, shield case should connect to the ground.

9.2 Environment

- (1) Working environment of the panel should in the clean room.
- (2) The front poliazzer is easy damaged, handle it carefully and do not scratch it by sharp material.
- (3) Panel has polarizer protective film in the surface please remove the protection film of polarizer slowly with ionized air to prevent the electrostatic discharge.

9.3 Others

- (1) Turn off the power supply before connecting and disconnecting signal input cable.
- (2) The connection area of FPC and panel is very weak, do not handle panel only by FPC or bend FPC.
- (3) Water drop on the surface or condensation as panel power on will corrode panel electrode.
- (4) As the packing bag open, watch out the environment of the panel storage. High temperature and high humidity environment is prohibited.
- (5) When the TFT LCD module is broken, please watch out whether liquid crystal leaks out or not. If your hand touches liquid crystal, wash your hand cleanly by water and soap as soon as possible.

10. MECHANICAL DRAWING

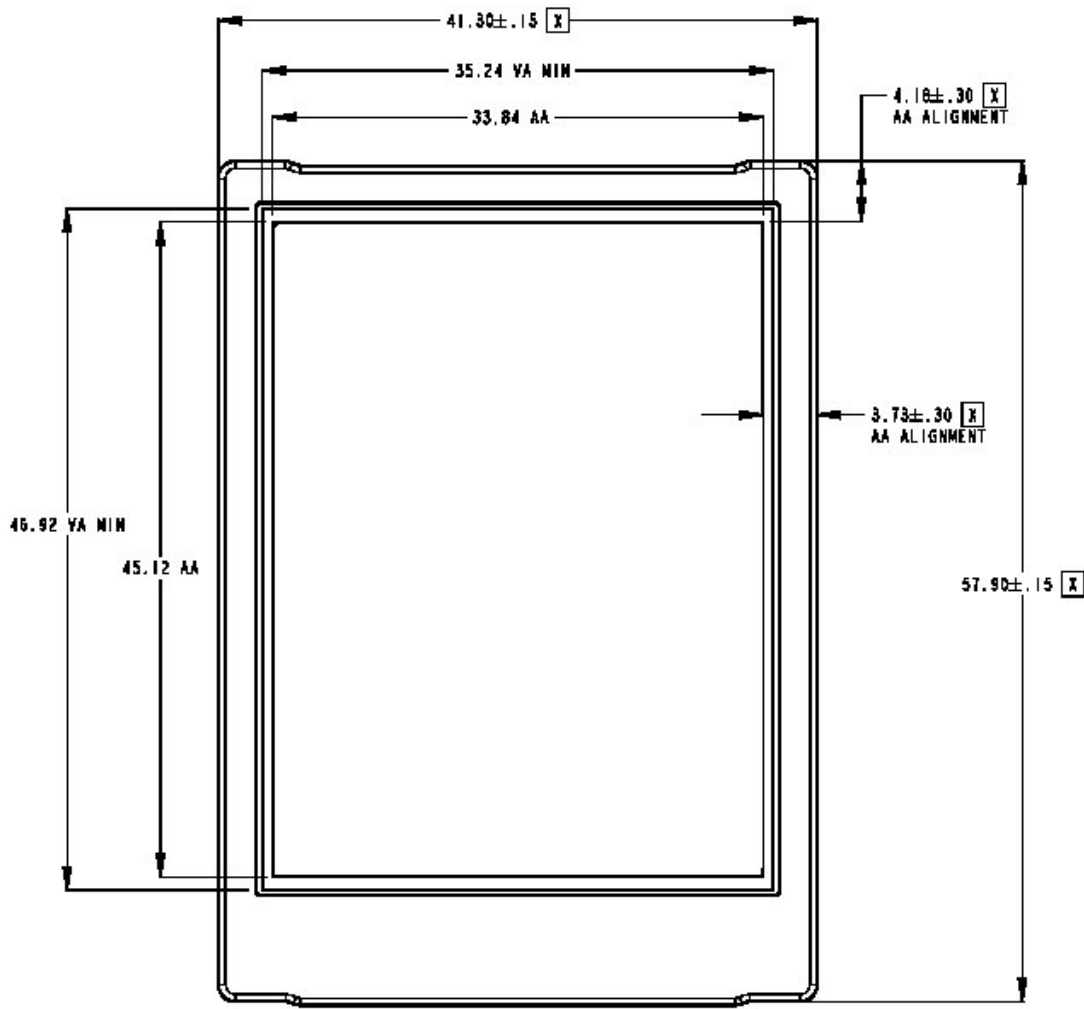

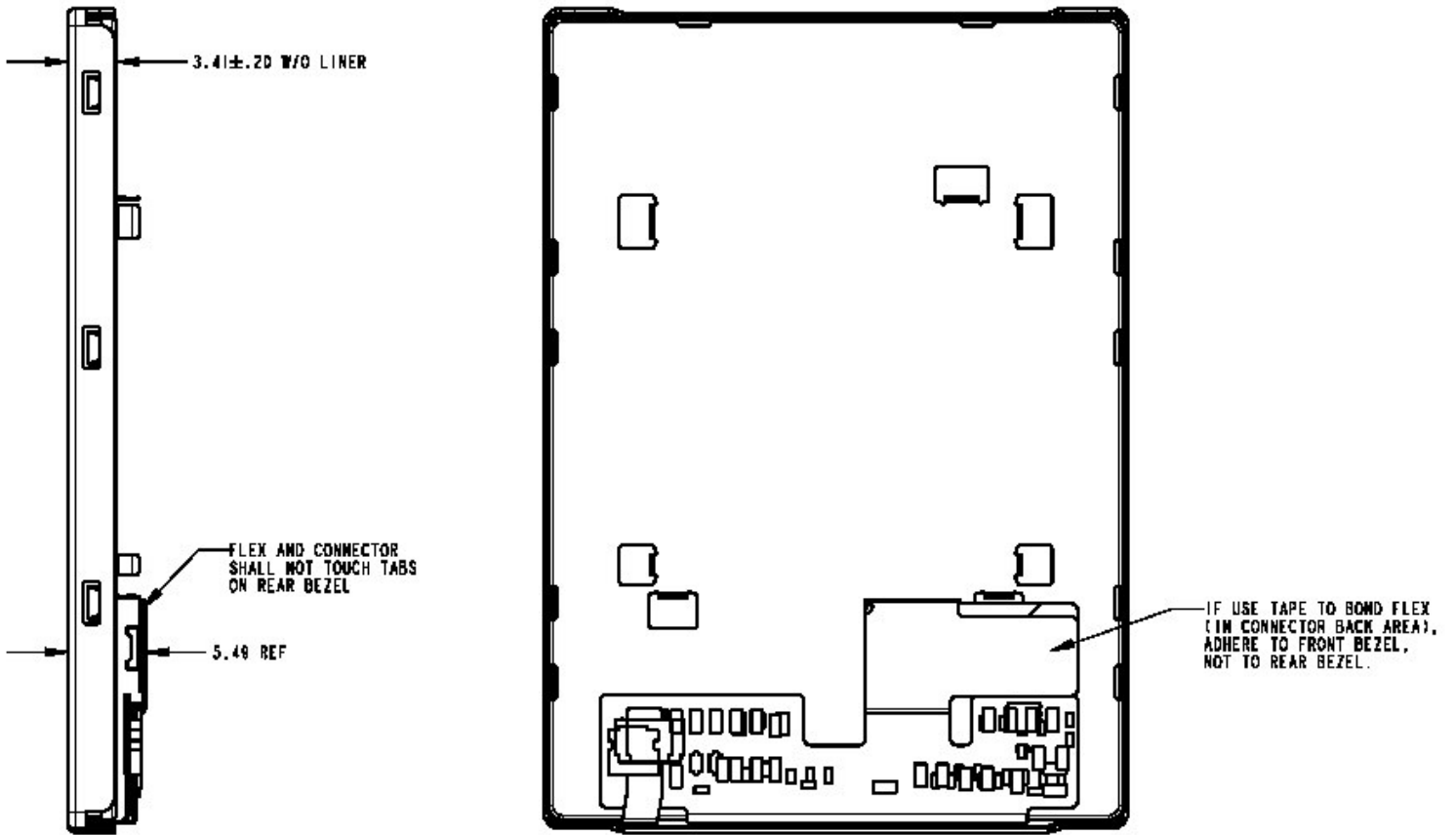

11. Packing Drawing

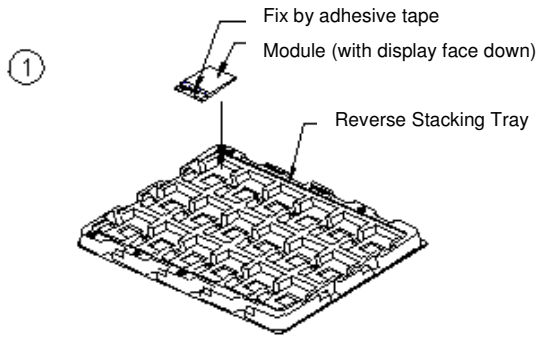

Module Qty in one Tray = 18 pcs

②

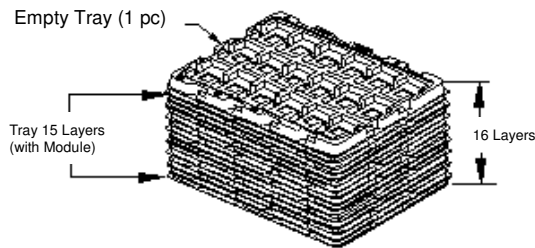

③

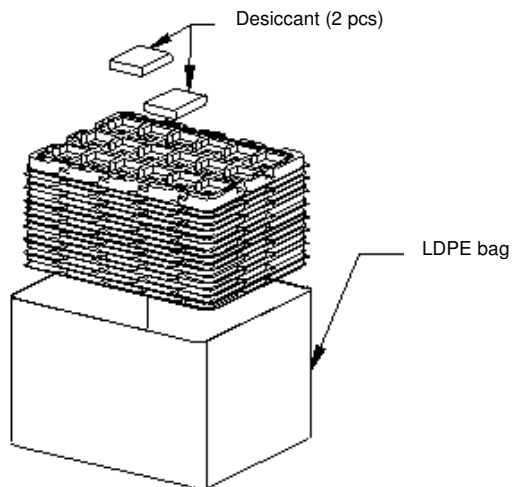

④

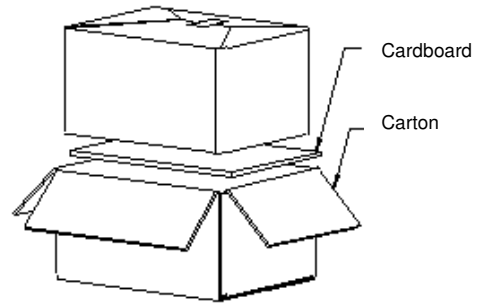

⑤

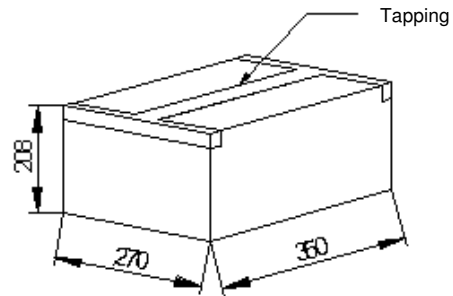

Module Quantity = 270 pcs / Carton