

# TFT LCD Specification

Model Name: **TD022SREC6**

<b>Customer Signature</b>
Date

## Table of Contents

<b>NO.</b>	<b>Item</b>	<b>Page</b>
	Cover Sheet	1
	Table of Contents	2
	Record of Revision	3
1	Features	4
2	General Specifications	4
3	Input / Output Terminals	5
4	Absolute Maximum Ratings	7
5	Electrical Characteristics	7
6	Input timing Chart	10
7	Optical Characteristics	13
8	Reliability	19
9	Handling Cautions	20
10	Mechanical Drawing	21
11	Packing Drawing	23

### Record of Revision

The information contained herein is the exclusive property of Toppoly Optoelectronics corporation, and shall not be distributed, reproduced, or disclosed in whole or in part without prior written permission of Toppoly Optoelectronics corporation.

Rev	Issued Date	Description
1.0	Apr. 10 2006	New issue
1.1	Jun 22 2006	Modify the 『 Mechanical Drawing 』 .

The information contained herein is the exclusive property of Toppoly Optoelectronics corporation, and shall not be distributed, reproduced, or disclosed in whole or in part without prior written permission of Toppoly Optoelectronics corporation.

**1. FEATURES**

The 2.2”(5.6 cm) LCD module is an trans-flective active matrix color TFT LCD module. LTPS (Low Temperature Poly Silicon) TFT technology is used. Vertical and horizontal drivers are built on the panel.

**2. GENERAL SPECIFICATIONS**

Item	Description	Unit
Display Size (Diagonal)	2.2 (5.6)	Inch (cm)
Display Type	Trans-flective	
Active Area (HxV)	33.84 x 45.12	mm
Number of Dots (HxV)	240 x RGB x 320	dot
Dot Pitch (HxV)	0.047 x 0.141	mm
Color Arrangement	RGB Stripe	
Color Numbers	65536 (bit: R=5, G=6, B=5)	
Outline Dimension (HxVxT)	40.6 x 56.6 x 2.91	mm
Weight	TBD	g

\* Exclude FPCa and protrusions.

### 3. INPUT/OUTPUT TERMINALS

No.	Pin Name	I/O	Description	Note
1	/RESETB	I	When /RESETB is L,an internal reset is performed	
2	TB	I	Data shift direction select	Note 1
3	RL	I	Source shift direction select	Note 2
4	NC	-	NC	
5	GND	-	Ground	
6	MCLK	I	The pixel clock signal of the RGB interface	
7	GND	-	Ground	
8	GND	-	Ground	
9	GND	-	Ground	
10	B1	I	RGB data Bit B1	
11	B2	I	RGB data Bit B2	
12	B3	I	RGB data Bit B3	
13	B4	I	RGB data Bit B4	
14	B5	I	RGB data Bit R5(MSB)	
15	GND	-	Ground	
16	G0	I	RGB data Bit G0	
17	G1	I	RGB data Bit G1	
18	G2	I	RGB data Bit G2	
19	G3	I	RGB data Bit G3	
20	G4	I	RGB data Bit G4	
21	G5	I	RGB data Bit G5(MSB)	
22	GND	-	Ground	
23	R1	I	RGB data Bit R1	
24	R2	I	RGB data Bit R2	
25	R3	I	RGB data Bit R3	
26	R4	I	RGB data Bit R4	
27	R5	I	RGB data Bit B5(MSB)	
28	GND	I	Ground	
29	HSYNC	I	The horizontal sync signal of the RGB interface	
30	VSYNC	I	The vertical sync signal of the RGB interface	
31	DE	I	Data Enable	
32	GND	-	Ground	
33	DVDD	-	Power supply	

No.	Pin Name	I/O	Description	Note
34	DVDD	-	Power supply	
35	LED+	-	LED+	
36	LED+	-	LED+	
37	LED-	-	LED-	
38	LED-	-	LED-	
39	GND	-	Ground	

**Note1:**

**Note2:**

TB = H

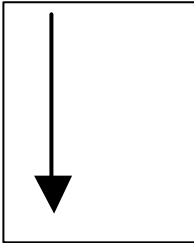

TB = L

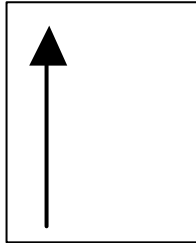

RL = H

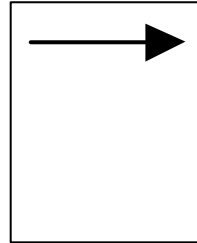

RL = L

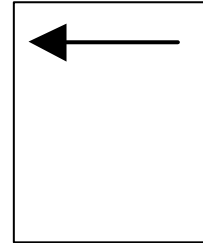

#### 4. ABSOLUTE MAXIMUM RATINGS

Parameter	Symbol	Ratings	Unit
Maximum supply voltage	DVDD	-0.3 ~ +3.6	V
DC/DC Input voltage	DVDD	-0.3 to DVDD +0.3	V

( $T_a=+25$  ,  $V_{SS}=0V$ )

#### 5. ELECTRICAL CHARACTERISTICS

Allowable Operation condition ( $T_a=-20 \sim +60$  ,  $V_{SS}=0$ )

Parameter	Symbol	Conditions	Ratings			Unit	
			MIN	TYP	MAX		
Supply Voltage (DC/DC)	DVDD		2.5	2.8	3.6	V	
Logic high-level input	$V_{ih}$		0.7 DVDD	-	DVDD	V	
Logic low-level input	$V_{il}$		0	-	0.3 DVDD	V	
Leakage Current	$i_L$		-1	-	1	A	
Input Signal Voltage	$H_{SYNC}$ $V_{SYNC}$ signals	HS VS	1.6	2.8	3.6	V	
	Data Signals	R,G, B	1.6	2.8	3.6	V	
	Clock signal	CLK	1.6	2.8	3.6	V	
Power consumption	Normal mode	Pwr	With loading	-	3.5	-	mW

Power On sequence

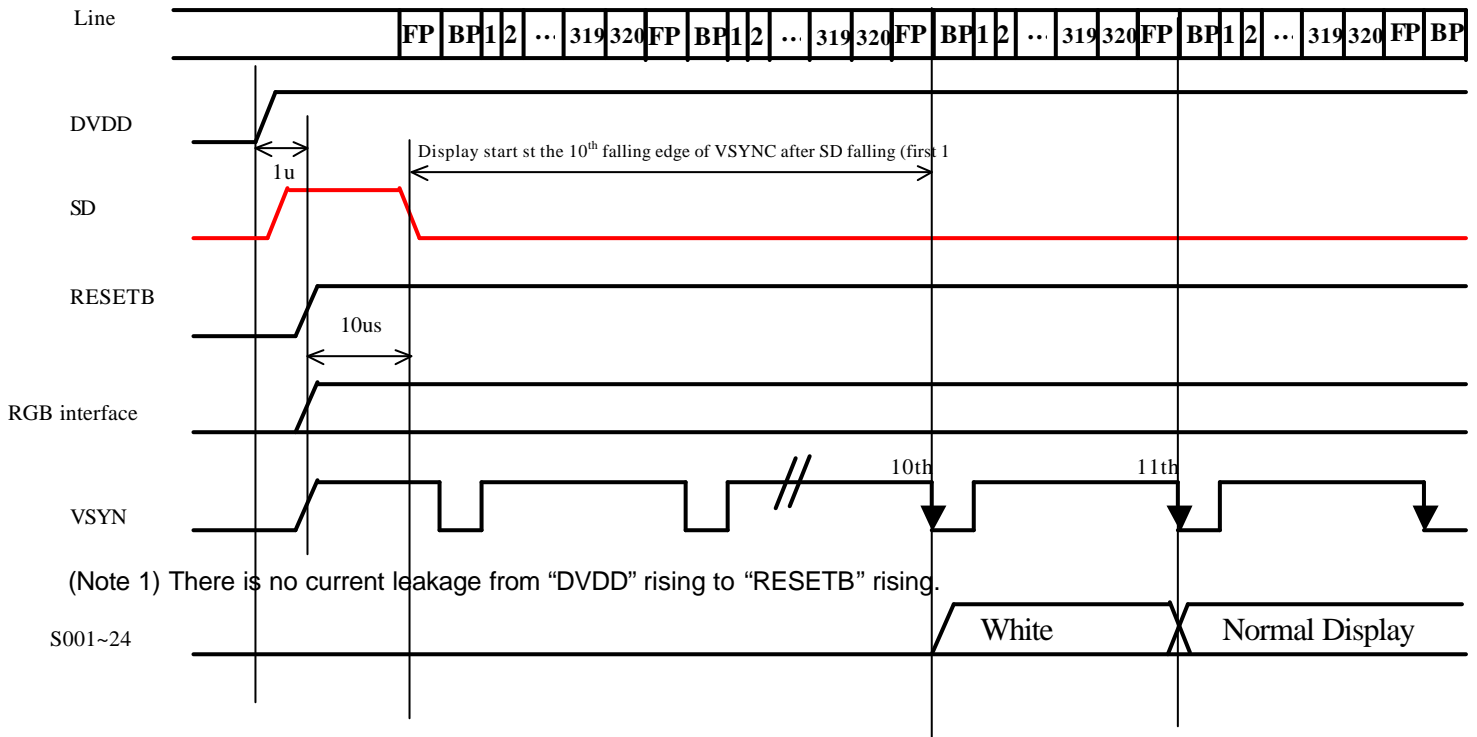

Power Off sequence

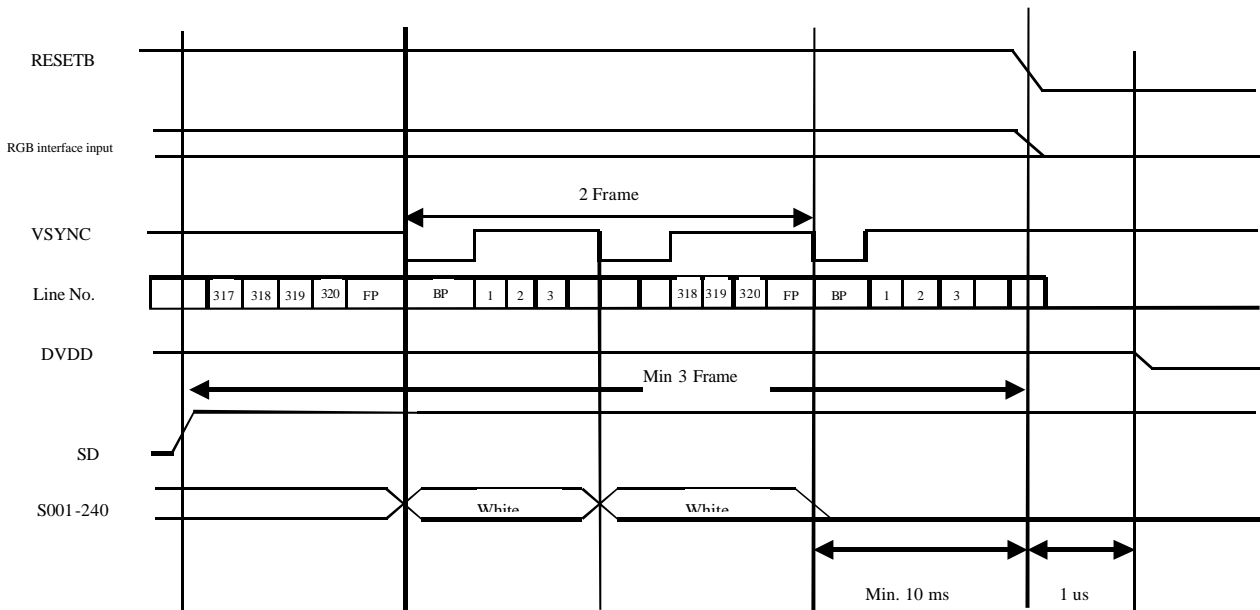



5.1 Driving TFT LCD panel block diagram

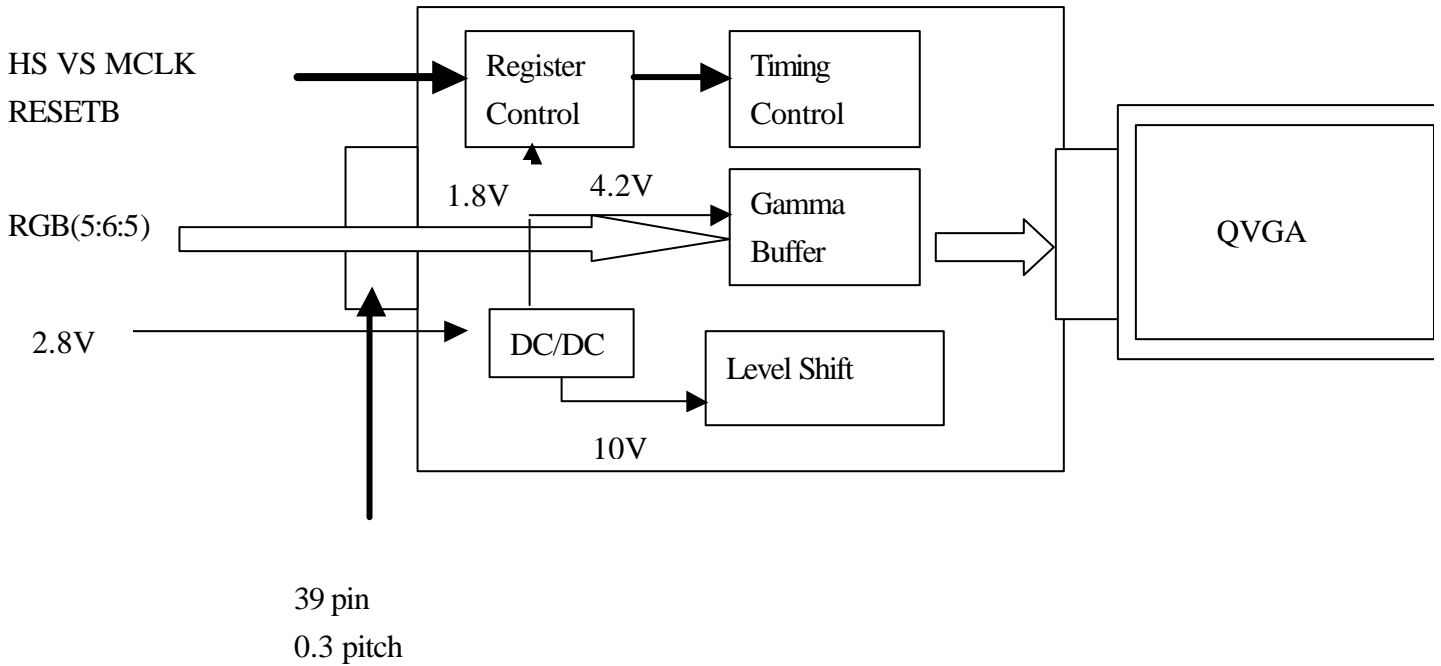

5.2 Driving Backlight

Ta=25

Item	Symbol	MIN	TYP	MAX	Unit	Remark
Forward Current	$I_F$	--	15	TBD	mA	
Forward Current Voltage	$V_F$	--	14.4	--	V	Note 5-2
Backlight Power Consumption	$W_{BL}$	--	216	--	mW	

Note 5-2: LEDx4

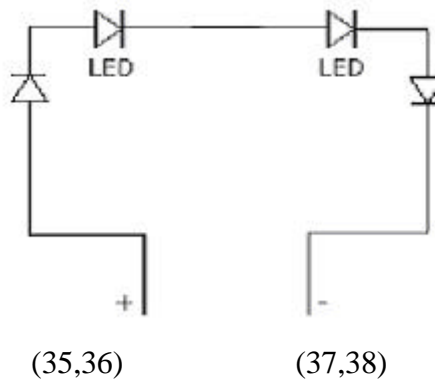

## 6. Input timing chart

### 6.1 Vertical Timing chart

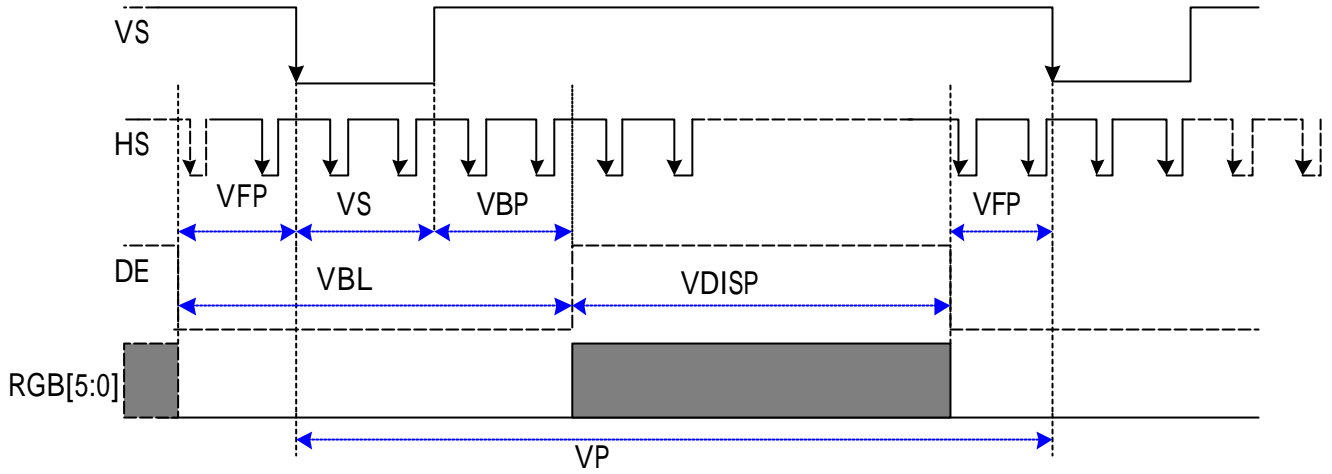

### 6.2 Horizontal Timing chart

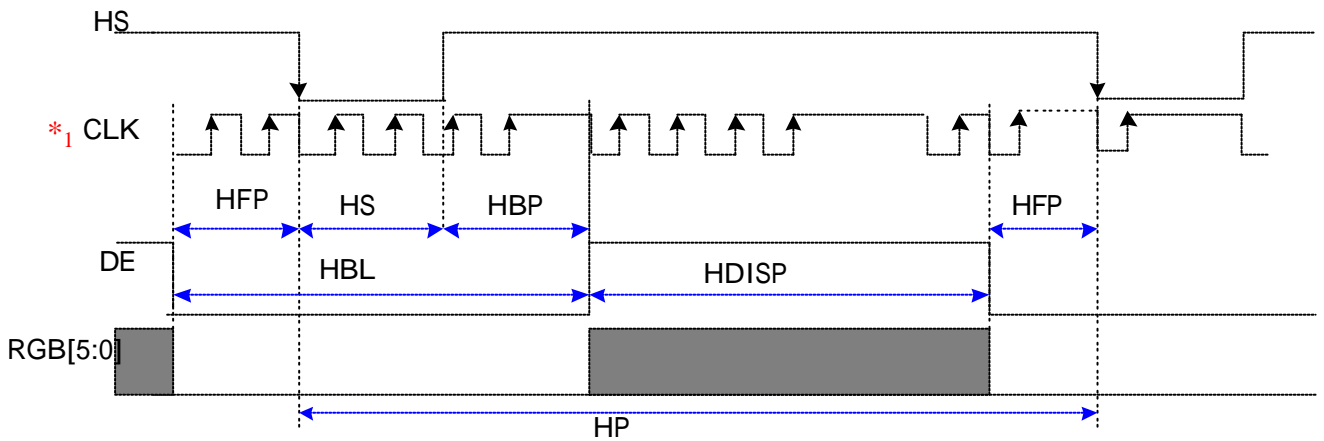

1. The frequency of CLK should be continued whether in display or blank region to ensure IC operating normally.

6.3. Setup/ Hold Timing chart

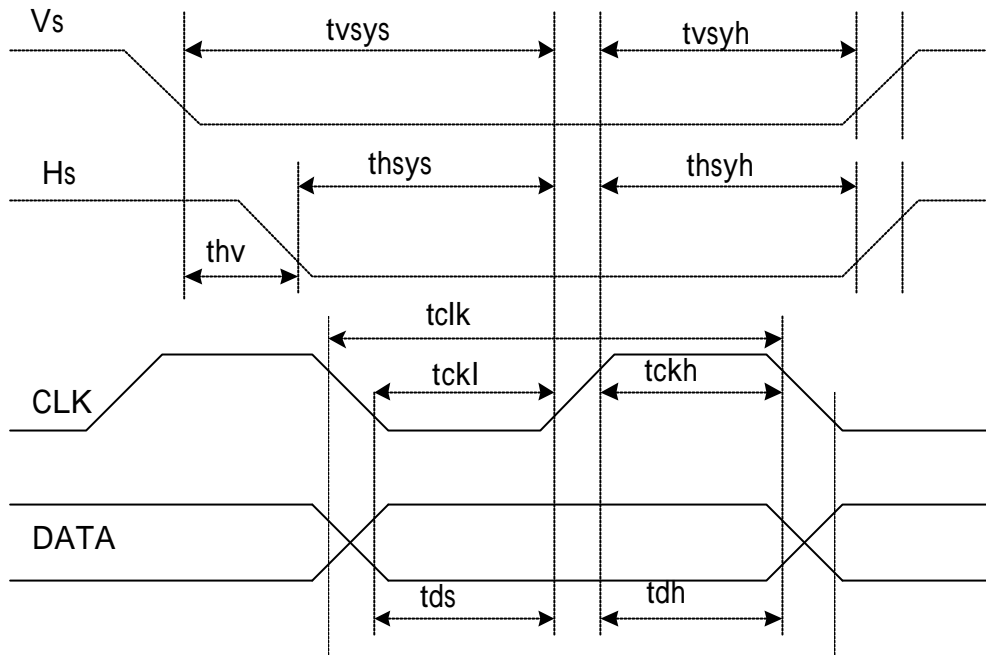

Phase difference of Sync.  
Maximum Timing chart :

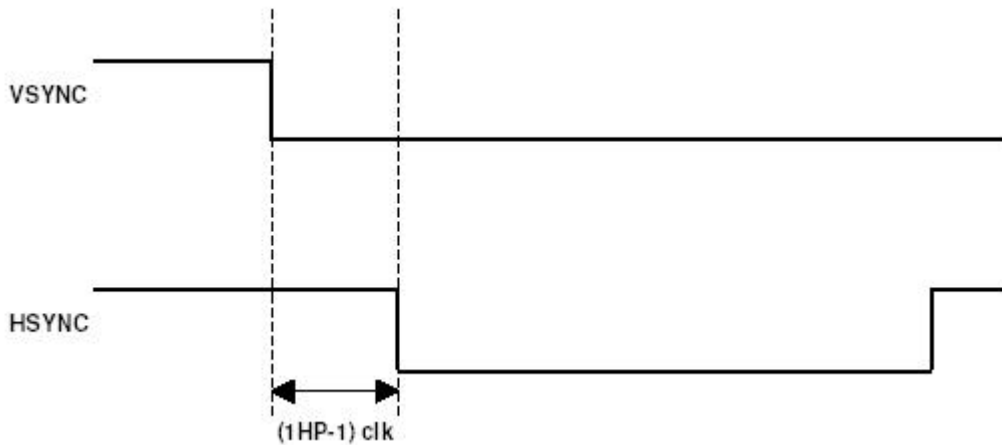

Minimum Timing chart:

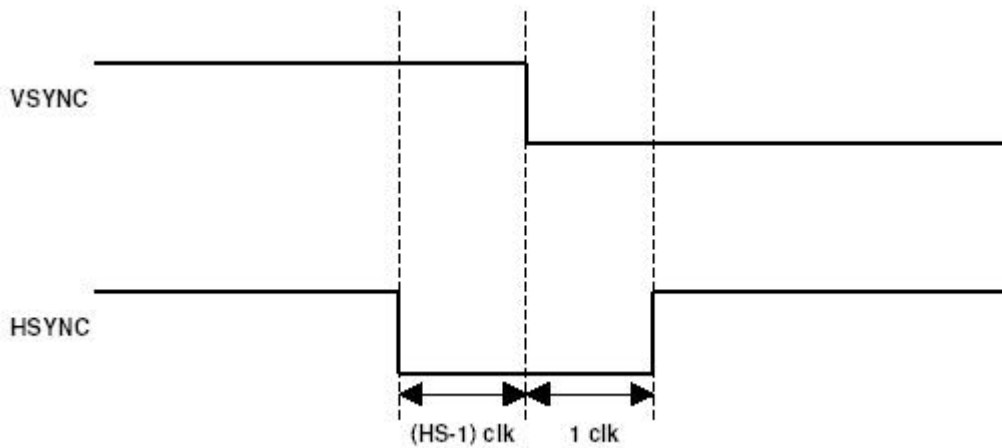

6.4 AC Characteristics:

Parameter	Symbol	Conditions	Ratings			Unit
			MIN	TYP	MAX	
Vertical Sync. Setup time	tvsys		20	-	-	ns
Vertical Sync. Hold time	tvsyh		20	-	-	ns
Horizontal Sync. Setup time	thsys		20	-	-	ns
Horizontal Sync. Hold time	thsyh		20	-	-	ns
Phase difference of Sync. Signal Falling edge	thv		-(HS-1)	-	1HP-1	clk
Clock "L" Period	tckl		30	50	70	%
Clock "H" Period	tckh		30	50	70	%
Data setup time	tds		20	-	-	ns
Data Hold time	tdh		20	-	-	ns
Digital logic input	Trise/Tfall				15	ns

**7. OPTICAL CHARACTERISTICS**

7.1. Transmissive Mode (T = 25 deg C, T=0°, Backlight ON)

Item	Symbol	Condition	MIN	TYP	MAX	Unit	Remarks			
Viewing Angles	T 11(L)	CR = 10	45	55	-	Degree	Note 7-1			
	T12(R)		35	45	-					
	T21(D)		50	60	-					
	T22(U)		35	45	-					
Chromaticity	White	T=0°	X	0.26	0.31	0.36	-	Note 7-3		
			Y	0.27	0.32	0.37				
	Red		X	0.54	0.59	0.64				
			Y	0.29	0.34	0.39				
	Green		X	0.27	0.32	0.37				
			Y	0.52	0.57	0.62				
	Blue		X	0.09	0.14	0.19				
			Y	0.08	0.13	0.18				
	NTSC		T=0°	43	50	-			%	Note 7-3
	Contrast Ratio		CR	T=0°	120	150			-	-
Uniformity (9 point)	Uf	T=0°	75	80		%	Note 7-7			
Luminance	L	T=0°	145	195	-	Cd/m <sup>2</sup>	Note 7-4			

7.2. Reflective Mode (T = 25 deg C, T=0°, Backlight off)

Item	Symbol	Condition	MIN	TYP	MAX	Unit	Remarks				
Viewing Angles	T 11(L)	CR = 2	70	75	-	-	Note 7-1 (system A)				
	T12(R)		70	75	-						
	T21(D)		70	75	-						
	T22(U)		65	75	-						
Chromaticity	White	T=0°	X	0.25	0.30	0.35	-	Note 7-5			
			Y	0.29	0.34	0.39					
	Red		X	0.33	0.38	0.43					
			Y	0.29	0.34	0.39					
	Green		X	0.24	0.29	0.34					
			Y	0.35	0.40	0.45					
	Blue		X	0.14	0.19	0.24					
			Y	0.15	0.20	0.25					
			NTSC	T=0°	4.5	6.5			-	%	Note 7-5
	Contrast Ratio		CR	T=0°	5.0	8.0			-	-	Note 7-2
Response time	(Tr+Tf)/2	T=0°	-	7	14	-	Note7-8				
Diffuse reflectance of display driven white	R <sub>w</sub>	T=0°	2.5	3.5	-	%	Note7-9				
Reflectance (Point light source)	R <sub>10</sub>	T =10° F=270°	12	20	-	%	Note7-6				

7.2.1 Ambient Temperature: Ta=25

7.2.2 Testing Point: Measure in the display center point and the test angle =0 °  
Measuring System A (Autronic-Melchers DMS-series)

7.3 Basic measure condition

7.3.1 Driving voltage

VDD= 12.0V, VEE=-6.5V

7.3.2 Ambient temperature: Ta=25

7.3.3 Testing point: measure in the display center point and the test angle T=0 °

7.3.4 Testing Facility

Environmental illumination: = 1 Lux

A. System A

Set up:

- a. Device: Autronic-Melchers DMS-series
- b. Detector: Spectrometer (or photometer)
- c. Light source: DMS hemisphere without secular reflection (temperature stage), standard distance 3mm
- d. Labsphere standard diffuse reflective white sample (SRS-99-020)
- e. Detector angle: perpendicular (θ=0°); the hemisphere slit position is at φ=90
- f. Detector position: screen center (x=0, y=0)
- g. Spectrometer evaluation light source: D65

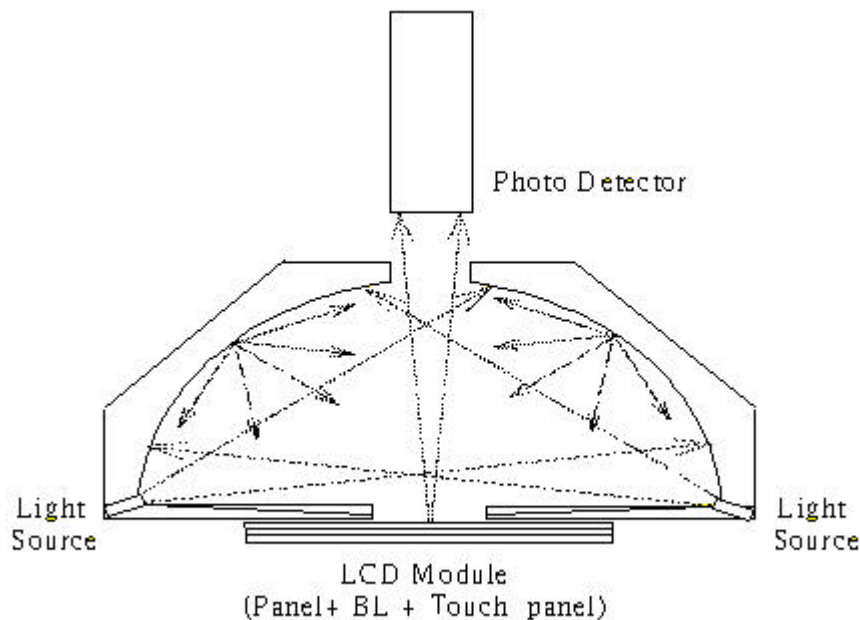

B. System B

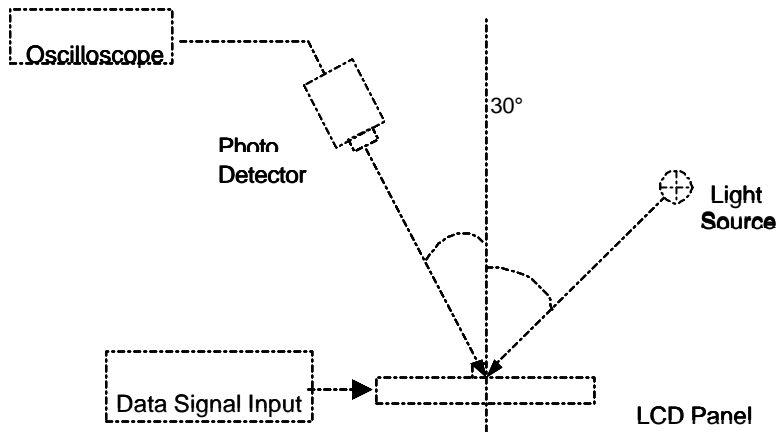

C. System C

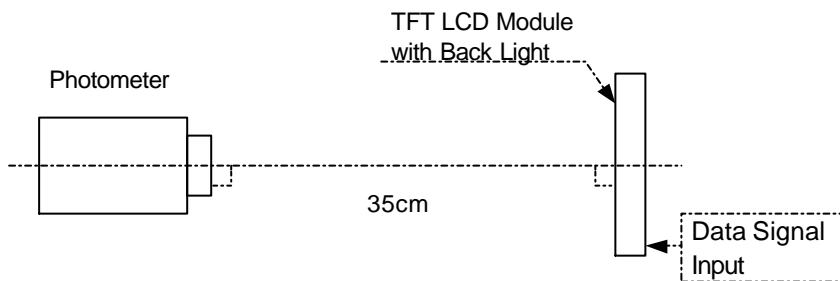

Note 7-1: Viewing angle diagrams:

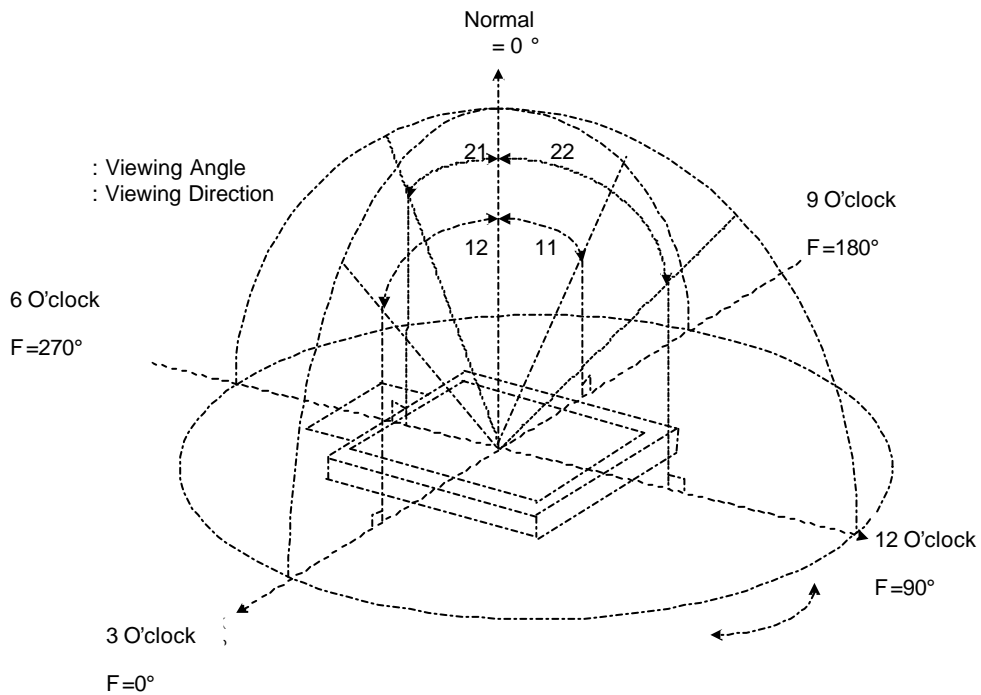



Note 7-2: Contrast ratio in back light on (Measure System C)  
Contrast ratio in back light off (Measure System A)

Contrast ratio is measured in optimum common electrode voltage.

$$CR = \frac{\text{Luminance with all white pixels}}{\text{Luminance with all black pixels}}$$

Note 7-3: White chromaticity as back light on: (Measure System C)

Note 7-4: Luminance: (Measure System C)

Test Point: Display Center

LED Current  $I_f = 15 \text{ mA}$

Note 7-5 White chromaticity as back light off: (Measure System A)

Note 7-6: Reflection ratio (R) (Measure System B)

In the measuring system B, calculate the reflection ratio by the following formula.

$$\text{Reflection ratio}(R) = \frac{\text{Light detected level of refection by the LCD module}}{\text{Light detected level of refection by the standard white}}$$

Notes 7-7: Definition of uniformity: Light on backlight 9 minutes before test.

$$\text{Uniformity (Lu)} = \frac{\text{Minimum Luminance of 9 test points}}{\text{Maximum Luminance of 9 test points}} \times 100\%$$

Note 7-8: Definition of response time: (Measure System A)

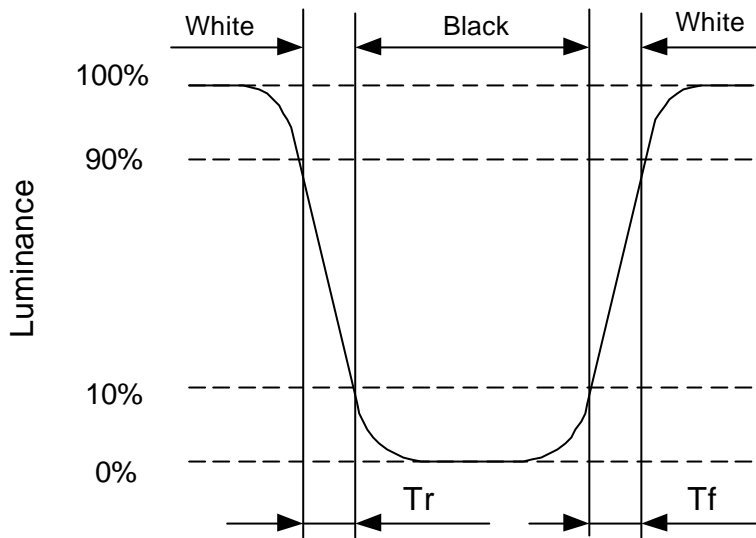

Note7-9: Diffuse reflectance of display driven white:

In the measuring system A, calculate the reflection ratio by the following formula.

$$\text{Reflection ratio}(R) = \frac{\text{Light detected level of refection by the LCD module (White pattern)}}{\text{Light detected level of refection by the standard white}}$$

8. RELIABILITY

No	Test Item	Condition
1	High Temperature Operation	Ta= 60 , 240hrs
2	High Temperature & High Humidity Operation	Ta= 40 , 95% RH, 240hrs
3	Low Temperature Operation	Ta=-10 , 240hrs
4	High Temperature Storage	Ta=+80 , 240hrs
5	Low Temperature Storage	Ta=-20 , 240hrs
6	Thermal Shock (non-operation)	-40 (45min) 85 (45min) , 30 cycles
7	Vibration (non-operation)	Frequency: 10~55Hz; Amplitude: 1.5mm Sweep Time: 11min Test Time: 2 hrs for each direction of X, Y, Z
8	Shock (non-operation)	Acceleration: 100G; Period: 6ms Directions: ±X, ±Y, ±Z; Cycles: Twice

Ta: Ambient Temperature

## 9. HANDLING CAUTIONS

### 9.1 ESD (Electrical Static Discharge) Strategy

ESD will cause serious damage of the panel, ESD strategy is very important in handling. Following items are the recommended ESD strategy

- 9.1.1 In handling LCD panel, please wear non-charged material gloves. Connector the wrist conduction ring to the earth and the conducting shoes to the earth is necessary.
- 9.1.2 The machine and working table for the panel should have ESD protection strategy.
- 9.1.3 In handling the panel, using ionized air to decrease the charge in the environment is necessary.
- 9.1.4 In the process of assembly the module, shield case should connect to the ground.

### 9.2 Environment

- 9.2.1 Working environment of the panel should be in the clean room.
- 9.2.2 The front polarizer is easy damaged. Handle it carefully and do not scratch it by sharp material.
- 9.2.3 Panel has polarizer protective film in the surface. Please remove the protection film of polarizer slowly with ionized air to prevent the electrostatic discharge.

### 9.3 Others

- 9.3.1 Turn off the power supply before connecting and disconnecting signal input cable.
- 9.3.2 The connection area of FPC and panel is very weak, do not handle panel only by FPC or bend FPC.
- 9.3.3 Water drop on the surface or condensation as panel power on will corrode panel electrode.
- 9.3.4 As the packing bag open, watch out the environment of the panel storage. High temperature and high humidity environment is prohibited.
- 9.3.5 When the TFT LCD module is broken, please watch out whether liquid crystal leaks out or not. If your hand touches liquid crystal, wash your hand cleanly by water and soap as soon as possible.

10. MECHANICAL DRAWING

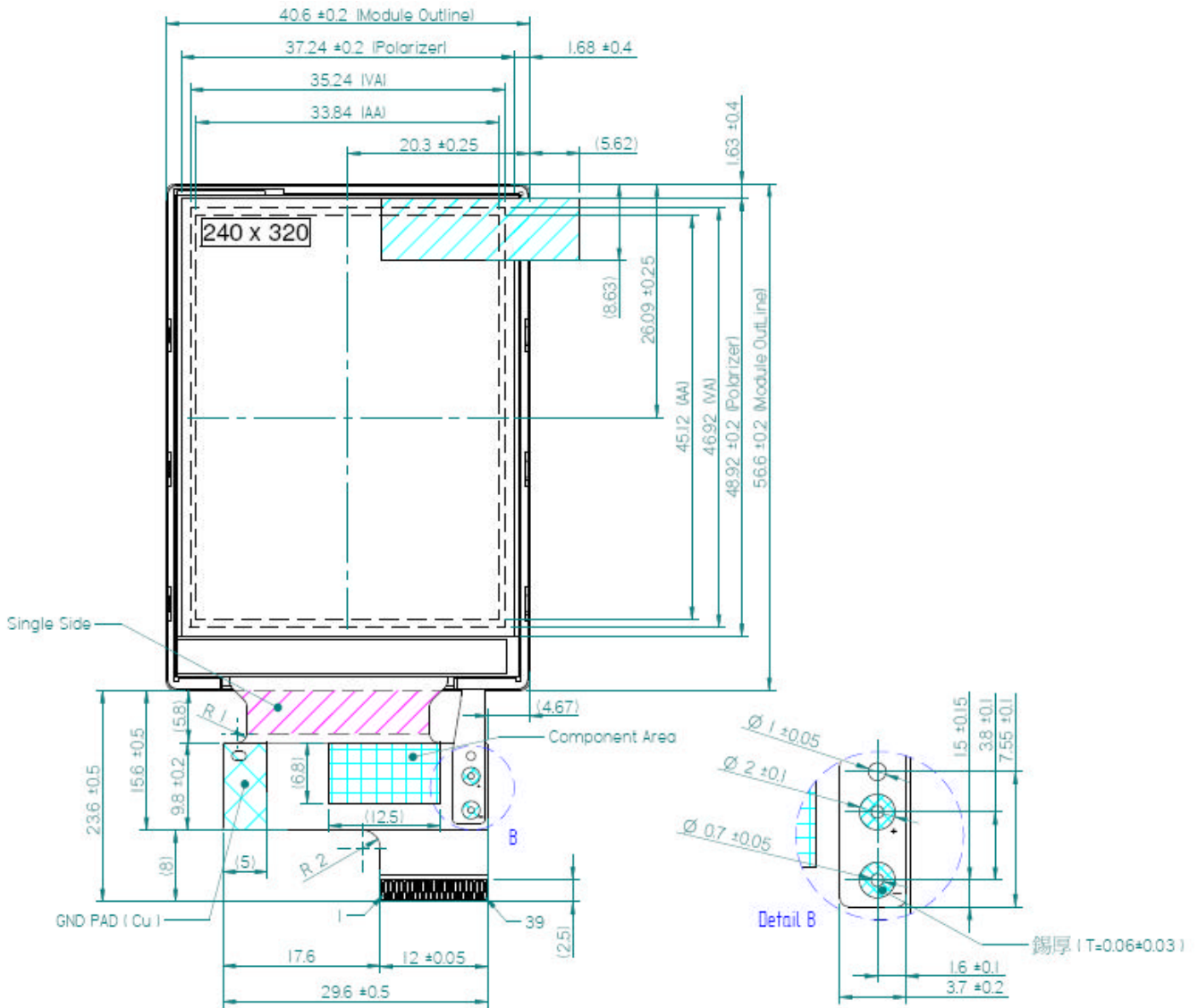

(Not including protection film and labels)

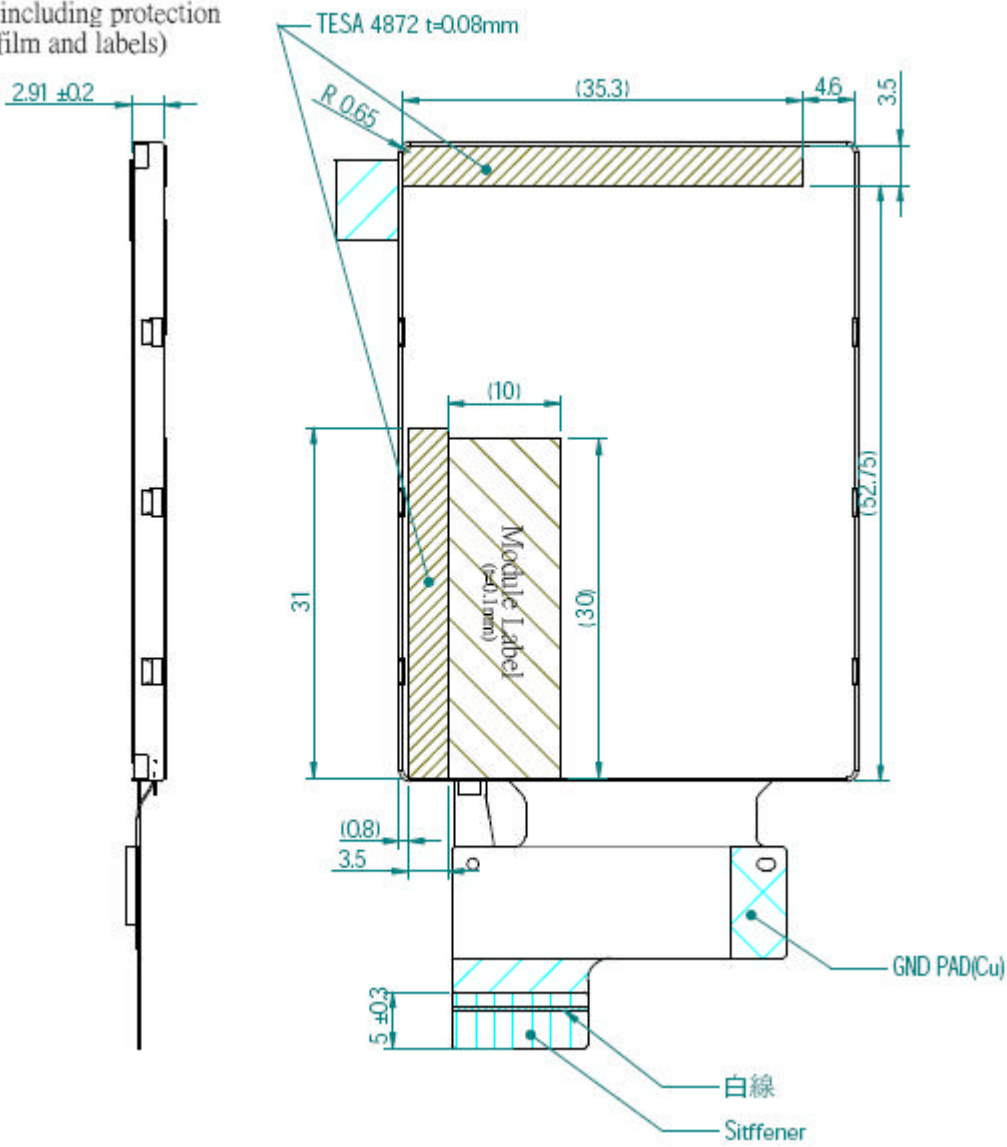

### 11. PACKING DRAWING

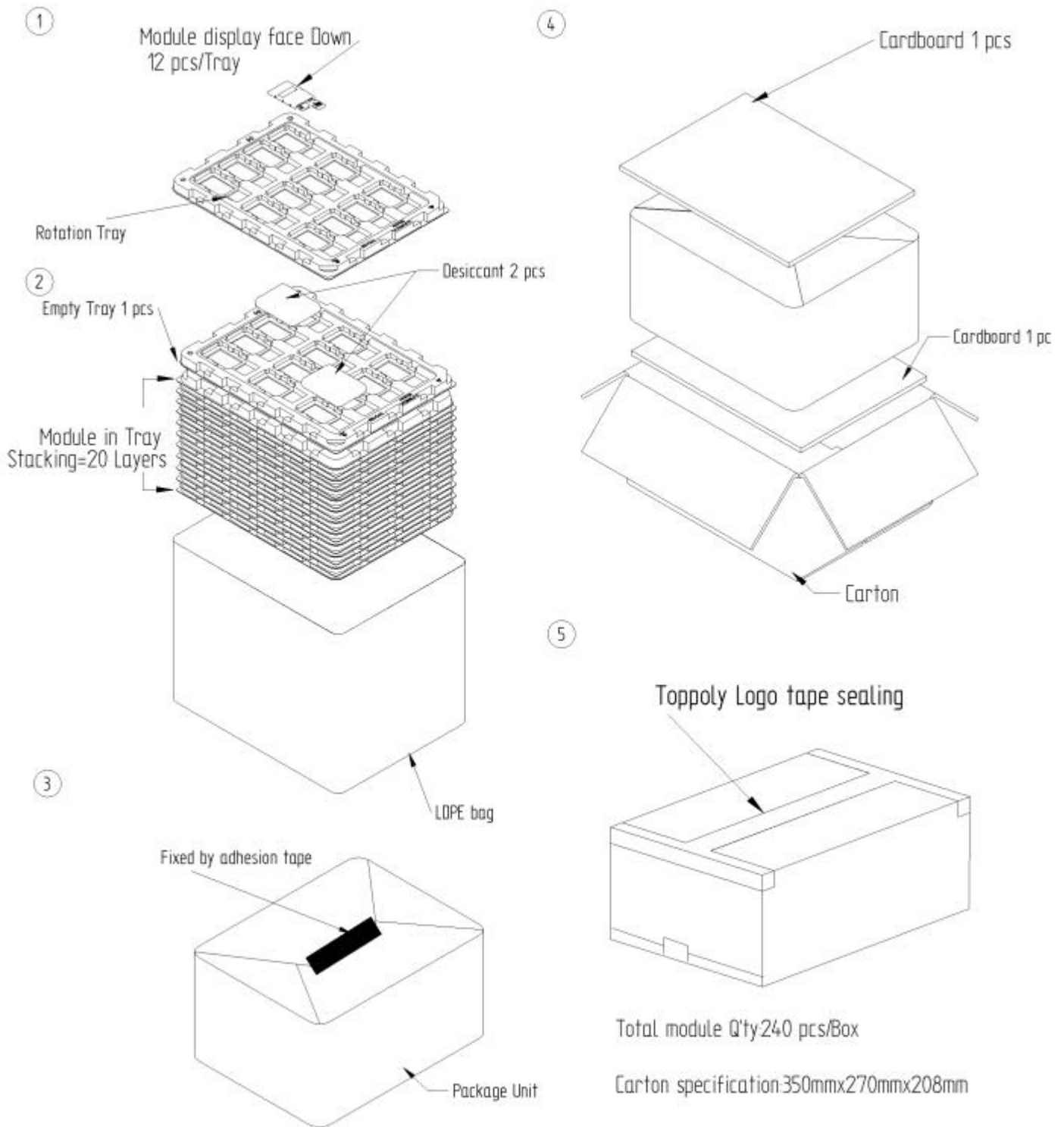

**TD022SREC5 Module delivery packing method**

- 11.1 Module packed into tray cavity (with Module display face down), and stacking tray of reverse 180 degree in order.
- 11.2 Stacking the production on tray with 20 layers and with 1 empty tray above the stacking tray unit, and put 2 Desiccant on the empty tray.
- 11.3 Stacking tray unit put into the LDPE bag and fix by adhesive tape.
- 11.4 Put 1 pcs cardboard inside the carton bottom, then pack the package unit into the carton, finally put 1 pcs cardboard above the package unit
- 11.5 Sealing the Carton with Toppoly Logo adhesive tape.