

LTPS LCD Specification

Model Name: TD030WHEA1

Customer Signature
Date

This technical specification is subjected to change without notice

The information contained herein is the exclusive property of toppoly Optoelectronics corporation, and shall not be distributed, reproduced, or disclosed in whole or in part without prior written permission of toppoly Optoelectronics corporation.

Table of Contents

NO.	Item	Page
	Cover Sheet	1
	Table of Contents	2
	Record of Revision	3
1	Features	4
2	General Specifications	4
3	Input / Output Terminals	5
4	Absolute Maximum Ratings	7
5	Electrical Characteristics	8
6	Timing Chart	9
7	Power Sequence	18
8	Optical Characteristics	19
9	Reliability	22
10	Handling Cautions	23
11	Mechanical Drawing	24
12	Packing Drawing	25



Record of Revision

Rev	Issue Date	Description
1.0	Aug. 01, 2007	New create.

The information contained herein is the exclusive property of toppoly Optoelectronics corporation, and shall not be distributed, reproduced, or disclosed in whole or in part without prior written permission of toppoly Optoelectronics corporation.

1. FEATURES

The 3.0" LCD module is the active matrix color TFT LCD module. LTPS (Low Temperature Poly Silicon) TFT technology is applied with vertical and horizontal drivers built on the panel.

Both of horizontal and vertical scan are reversible and controlled by the serial interface commands.

The product is designed for the requirement of the green product, and the specification complies with Toppoly's "Green Product Chemical Substance Specification Standard Hand Book".

2. GENERAL SPECIFICATIONS

Item	Description	Unit
Display Size (Diagonal)	3.0	Inch
Display Type	Transmissive	-
Active Area (HxV)	60.03 x 45	mm
Number of Dots (HxV)	960 x 240	Dot
Dot Pitch (HxV)	0.0625x0.1875	mm
Color Arrangement	RGB Delta	-
Color Numbers	16Million	-
Outline Dimension (HxVxT)	70.2x51.7x2.58*(Approx.)	mm
Weight	19.5	G
Panel surface treatment	Hard Coating(WV)	-

*Exclude FPC and protrusions.

3. INPUT/OUTPUT TERMINALS

3.1 TFT LCD Panel

Recommend connector:

Compatible with JAE IL-FHJ-39S-HF-A1, HRS FH23-39S-0.3SHW(0.5),
Molex SD54809 –3957 , IRISO 9671S39Y902

Pin	Symbol	I/O	Description	Remark
1	CP3	C	Capacitor for charge pump	
2	CP4	C	Capacitor for charge pump	
3	CP5	C	Capacitor for charge pump	
4	CP6	C	Capacitor for charge pump	
5	CP7	C	Capacitor for charge pump	
6	CP8	C	Capacitor for charge pump	
7	NC	--	No connection	
8	NC	--	No connection	
9	PCD	C	Capacitor for pre-charge data signal high	
10	VCOML	C	Capacitor for VCOM low	
11	VCOMH	C	Capacitor for VCOM high	
12	AGND	--	Analog ground	
13	NC	--	No connection	
14	AVDD	C	Regulation capacitor for analog voltage	
15	CP1	C	Capacitor for charge pump	
16	CP2	C	Capacitor for charge pump	
17	PWM	O	Power transistor gate signal for the boost converter	
18	FB	I	Main boost regulator feedback input	
19	LED-	--	LED power: cathode	Note 3-1
20	LED+	--	LED power: anode	
21	NC	--	No connection	
22	GND	--	Ground	
23	VCC	--	Power supply	
24	VD	I	Vertical sync input	
25	HD	I	Horizontal sync input	
26	DCLK	I	Clock signal, latch data onto line latches at the rising edge	
27	DIN0	I	Data input	
28	DIN1	I	Data input	
29	DIN2	I	Data input	
30	DIN3	I	Data input	

31	DIN4	I	Data input	
32	DIN5	I	Data input	
33	DIN6	I	Data input	
34	DIN7	I	Data input	
35	SDA	I/O	Serial interface data line	
36	SCL	I	Serial interface clock line	
37	SCEN	I	Serial interface chip enable line	
38	SHDB	I	Sleep mode setting pin	
39	GRESTB	I	Global reset pin	

Note 3-1: The figure below shows the connection of backlight LED.

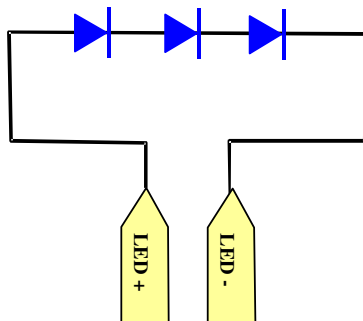

4. ABSOLUTE MAXIMUM RATINGS

Ta = 25°C

Item	Symbol	MIN	MAX	Unit	Remark
Logic Power Supply Voltage	V _{CC}	-0.5	4.5	V	
Input Signal Voltage	V _{IN1}	0	V _{CC}	V	VD, HD, DCLK, DIN[0:7], SDA, SCL, SCEN, SHDB, GRESTD
Back Light Forward Current	I _F	--	25	mA	
Operating Temperature	T _{OPR}	-10	+60	°C	
Storage Temperature	T _{STG}	-30	+80	°C	

5. ELECTRICAL CHARACTERISTICS

5.1 Driving TFT LCD Panel

GND=0V, Ta=25°C

Item	Symbol	MIN	TYP	MAX	Unit	Remark
Power Supply Voltage	V _{CC}	2.85	3.0	3.6	V	Note 5-1
Input Signal Voltage	Low Level	V _{IL}	GND	-	0.2x V _{CC} *	VD, HD, DCLK, DIN[0:7], SDA, SCL, SCEN, SHDB, GRESTD
	High Level	V _{IH}	0.8x V _{CC} *	-	V _{CC} *	
PWM Output Voltage	V _{PWM}	0	-	V _{CC} *	V	
Feedback Voltage	V _{FB}	0.55	0.6	0.65	V	Note 5-2
Panel Power Consumption	W _P	-	50	60	mW	

V_{CC}* =V_{CC}(TYP)

Note 5-1: The V_{CC} power is provided for overall panel module supply voltage.

Note 5-2: DC/DC feedback control voltage

5.2 Driving Backlight

Ta=25°C

Item	Symbol	MIN	TYP	MAX	Unit	Remark
Forward Current	I _F	--	23	25	mA	Note 5-3
Forward Current Voltage	V _F	--	9.6	10.8	V	
Backlight Power Consumption	W _{BL}	--	220.8	270	mW	

Note 5-3: Backlight driving circuit is recommended as the fix current circuit.

* Ta: Ambient Temperature

* High temperature operation: Test current refers the diagram as following.

* High Temperature & High Humidity Operation: Test current is 15mA.

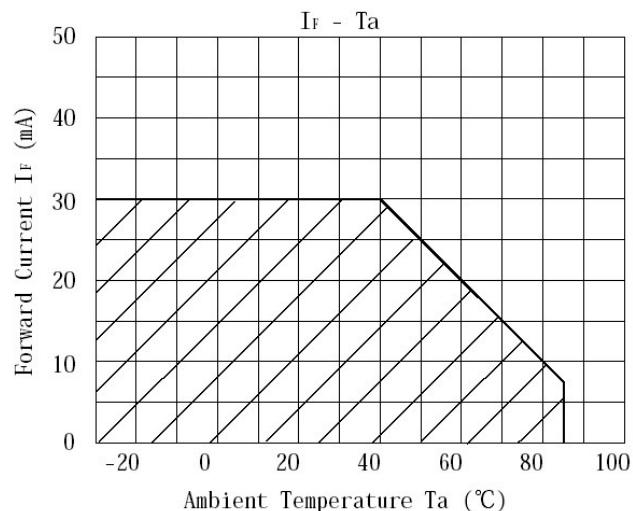

6. TIMING CHART

6.1 Serial RGB Dummy Mode and Serial YUV 4:2:2 Mode: Horizontal

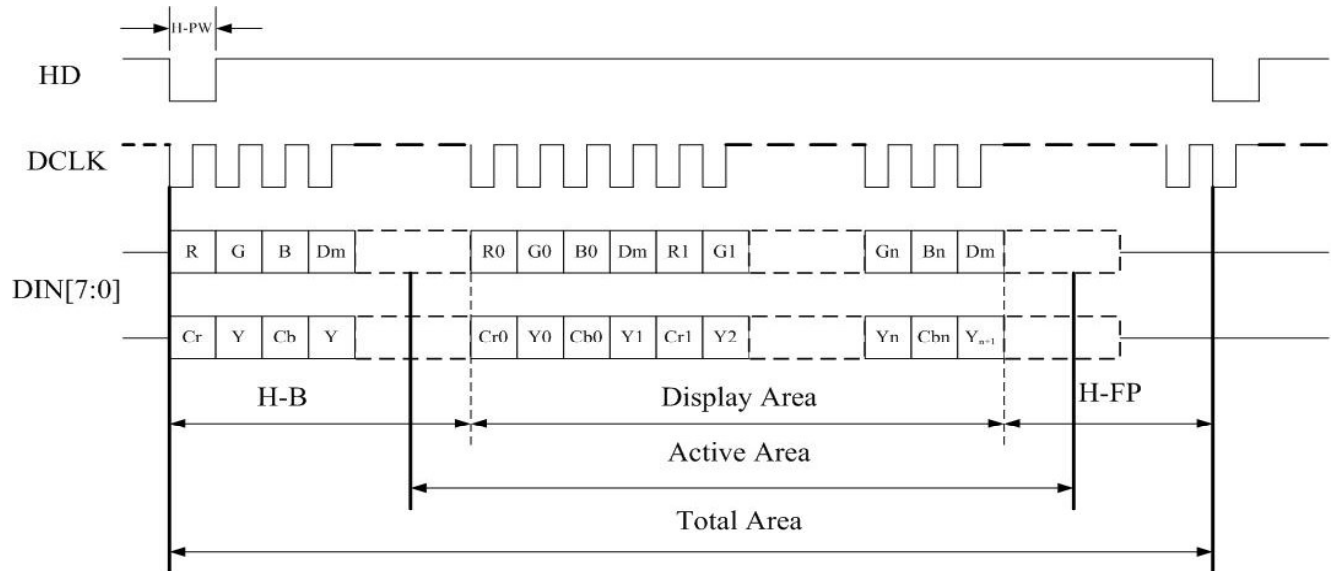

(1) YUV Mode: ITUR601-NTSC

Item	Symbol	MIN	TYP	MAX	Unit
Dot Clock Frequency	DCLK	-	27	-	MHz
Horizontal Display Active	Display Area	-	1440	-	DCLK
Horizontal Total Time	Total Area	-	1716	-	DCLK
HSYNC Pulse Width	H-PW	-	1	-	DCLK
Horizontal Back Porch	H-B	-	240	-	DCLK
Horizontal Front Porch	H-FP	-	36	-	DCLK

(2) YUV Mode: ITUR601-PAL

Item	Symbol	MIN	TYP	MAX	Unit
Dot Clock Frequency	DCLK	-	27	-	MHz
Horizontal Display Active	Display Area	-	1440	-	DCLK
Horizontal Total Time	Total Area	-	1728	-	DCLK
HSYNC Pulse Width	H-PW	-	1	-	DCLK
Horizontal Back Porch	H-B	-	240	-	DCLK
Horizontal Front Porch	H-FP	-	48	-	DCLK

(3) RGB Dummy Mode

Item	Symbol	MIN	TYP	MAX	Unit
Dot Clock Frequency	QVGA	-	25	-	MHz
	NTSC	-	24.54	-	
	PAL	-	24.38	-	
Horizontal Display Active	Display Area	-	1280	-	DCLK
Horizontal Total Time	Total Area	-	1560	-	DCLK
HSYNC Pulse Width	H-PW	-	1	-	DCLK
Horizontal Back Porch	H-B	-	240	-	DCLK
Horizontal Front Porch	H-FP	-	40	-	DCLK

6.2 Serial RGB Dummy Mode and Serial YUV 4:2:2 Mode: Vertical

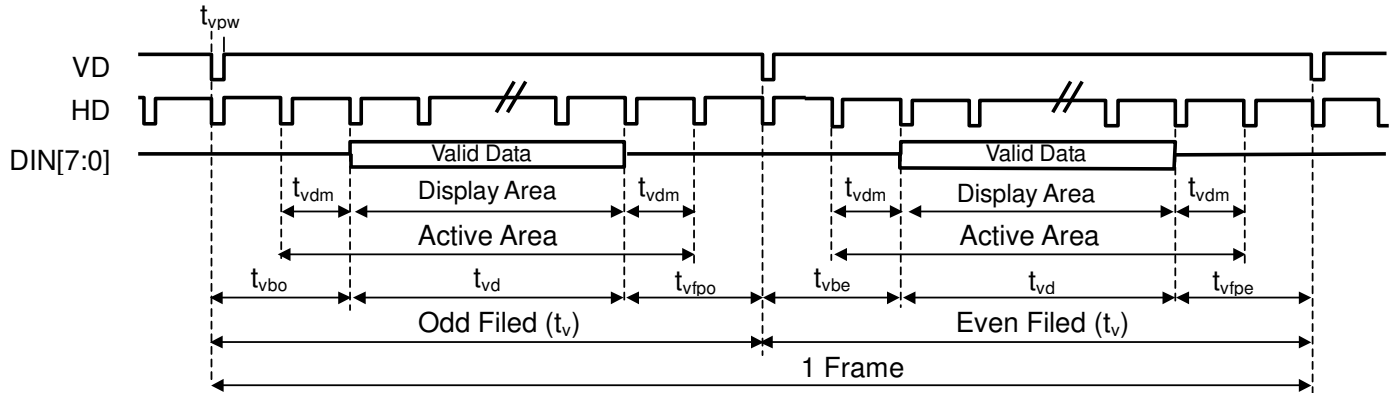

Non-interlace Mode

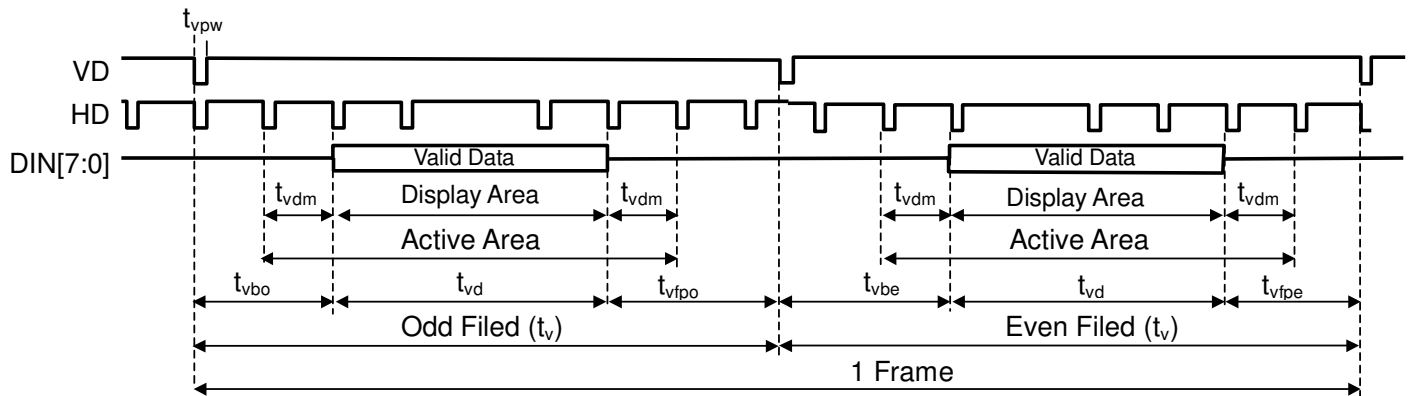

Interlace Mode

(1) Non-Interlace Mode: NTSC/QVGA

Item	Symbol	MIN	TYP	MAX	Unit	
Vertical Display Active	t_{vd}	-	240	-	Line	
Vertical Total Time	t_v	-	262	-	Line	
VSYNC Pulse Width	t_{vpw}	1	1	-	DCLK	
Vertical Back Porch	Odd Field	t_{vbo}	-	21	-	Line
	Even Field	t_{vbe}	-	21	-	Line
Vertical Front Porch	Odd Field	t_{vfpo}	-	1	-	Line
	Even Field	t_{vfpe}	-	1	-	Line
Vertical Dummy	t_{vdm}	-	0	-	Line	

(2) Non-Interlace Mode: PAL

Item	Symbol	MIN	TYP	MAX	Unit
Vertical Display Active	t_{vd}	-	288	-	Line
Vertical Total Time	t_v	-	312	-	Line
VSYNC Pulse Width	t_{vpw}	1	1	-	DCLK
Vertical Back Porch	Odd Field t_{vbo}	-	24	-	Line
	Even Field t_{vbe}	-	24	-	Line
Vertical Front Porch	Odd Field t_{vfpo}	-	0	-	Line
	Even Field t_{vfpe}	-	0	-	Line
Vertical Dummy	t_{vdm}	-	0	-	Line

(3) Interlace Mode: NTSC/QVGA

Item	Symbol	MIN	TYP	MAX	Unit
Vertical Display Active	t_{vd}	-	240	-	Line
Vertical Total Time	t_v	-	262.5	-	Line
VSYNC Pulse Width	t_{vpw}	1	1	-	DCLK
Vertical Back Porch	Odd Field t_{vbo}	-	21	-	Line
	Even Field t_{vbe}	-	21.5	-	Line
Vertical Front Porch	Odd Field t_{vfpo}	-	1.5	-	Line
	Even Field t_{vfpe}	-	1	-	Line
Vertical Dummy	t_{vdm}	-	0	-	Line

(4) Interlace Mode: PAL

Item	Symbol	MIN	TYP	MAX	Unit
Vertical Display Active	t_{vd}	-	288	-	Line
Vertical Total Time	t_v	-	312.5	-	Line
VSYNC Pulse Width	t_{vpw}	1	1	-	DCLK
Vertical Back Porch	Odd Field t_{vbo}	-	24	-	Line
	Even Field t_{vbe}	-	24.5	-	Line
Vertical Front Porch	Odd Field t_{vfpo}	-	0.5	-	Line
	Even Field t_{vfpe}	-	0	-	Line
Vertical Dummy	t_{vdm}	-	0	-	Line

6.3 Through Mode: Horizontal

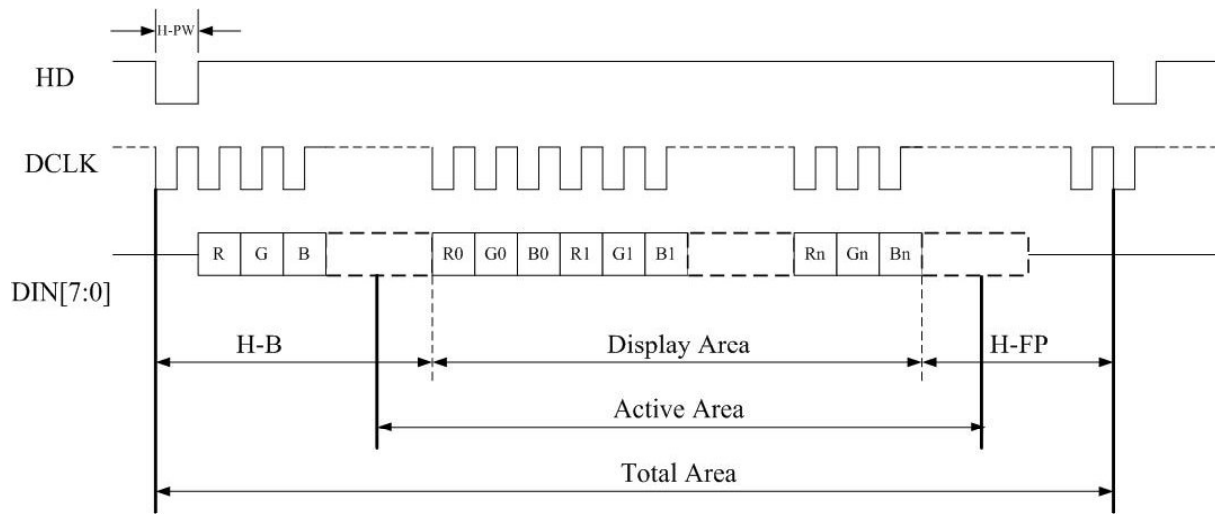

Item	Symbol	MIN	TYP	MAX	Unit
Dot Clock Period	DCLK	-	18.42	-	MHz
Horizontal Display Active	Display Area	-	960	-	DCLK
Horizontal Total Time	Total Area	-	1171	-	DCLK
HSYNC Pulse Width	H-PW	-	1	-	DCLK
Horizontal Back Porch	H-B	-	152	-	DCLK
Horizontal Front Porch	H-FP	-	59	-	DCLK

6.4 Through Mode: Vertical

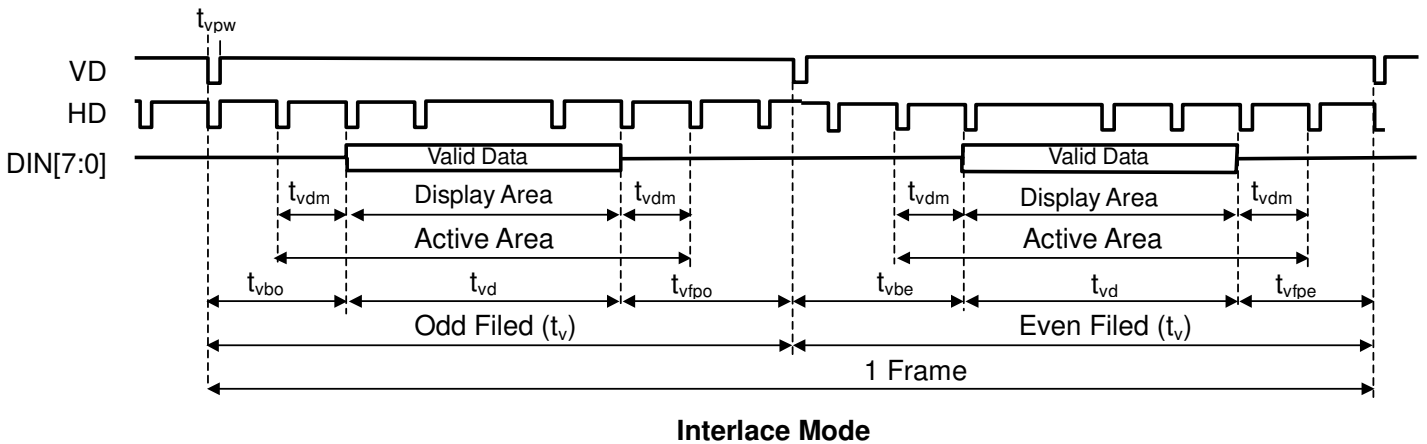
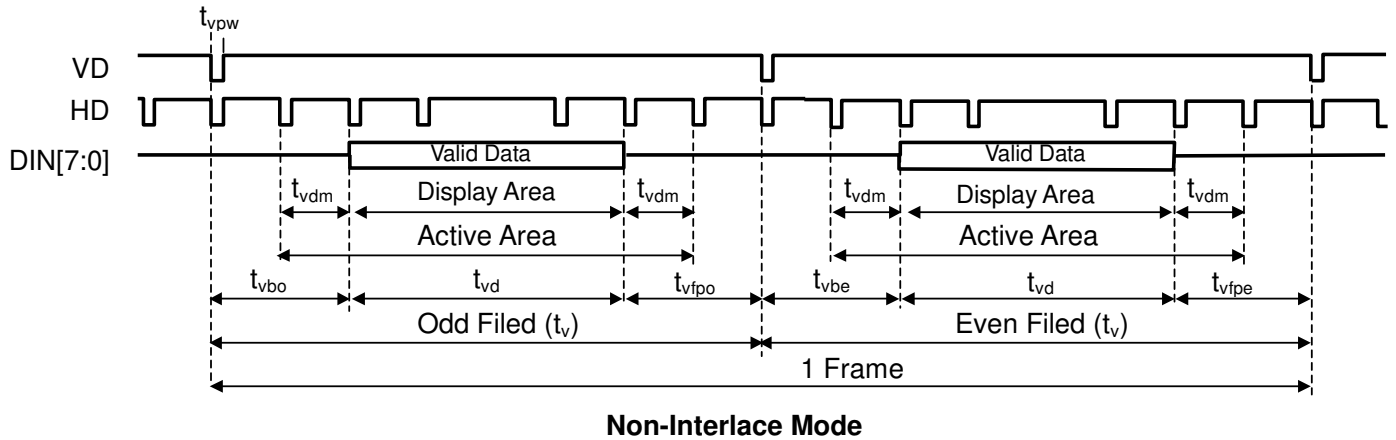

(1) Non-Interlace Mode

Item	Symbol	MIN	TYP	MAX	Unit	
Vertical Display Active	t_{vd}	-	240	-	Line	
Vertical Total Time	t_v	-	262	-	Line	
VSYSN Pulse Width	t_{vpw}	1	1	-	DCLK	
Vertical Back Porch	Odd Field	t_{vbo}	-	14	-	Line
	Even Field	t_{vbe}	-	14	-	Line
Vertical Front Porch	Odd Field	t_{vfpo}	-	8	-	Line
	Even Field	t_{vfpe}	-	8	-	Line
Vertical Dummy	t_{vdm}	-	0	-	Line	

(2) Interface Mode

Item	Symbol	MIN	TYP	MAX	Unit	
Vertical Display Active	t_{vd}	-	240	-	Line	
Vertical Total Time	t_v	-	262.5	-	Line	
VSYNC Pulse Width	t_{vpw}	1	1	-	DCLK	
Vertical Back Porch	Odd Field	t_{vbo}	-	14	-	Line
	Even Field	t_{vbe}	-	14.5	-	Line
Vertical Front Porch	Odd Field	t_{vfo}	-	8.5	-	Line
	Even Field	t_{vfe}	-	8	-	Line
Vertical Dummy	t_{vdm}	-	0	-	Line	

6.5 Setup Time and Hold Time

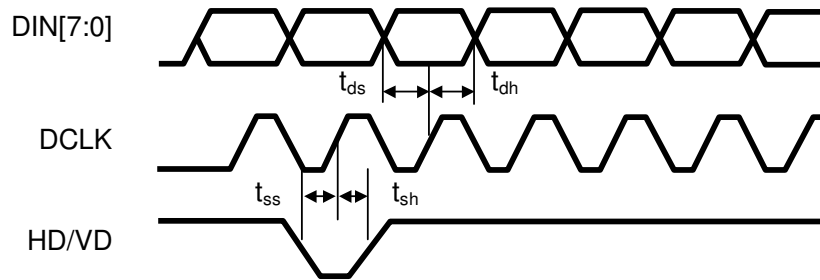

Item	Symbol	MIN	TYP	MAX	Unit
DCLK Duty Ratio	-	40	-	60	%
Data Setup Time	t_{ds}	12	-	-	ns
Data Hold Time	t_{dh}	12	-	-	ns
Control Signal Setup Time	t_{ss}	12	-	-	ns
Control Signal Hold Time	t_{sh}	12	-	-	ns

6.6 Serial Interface Timing

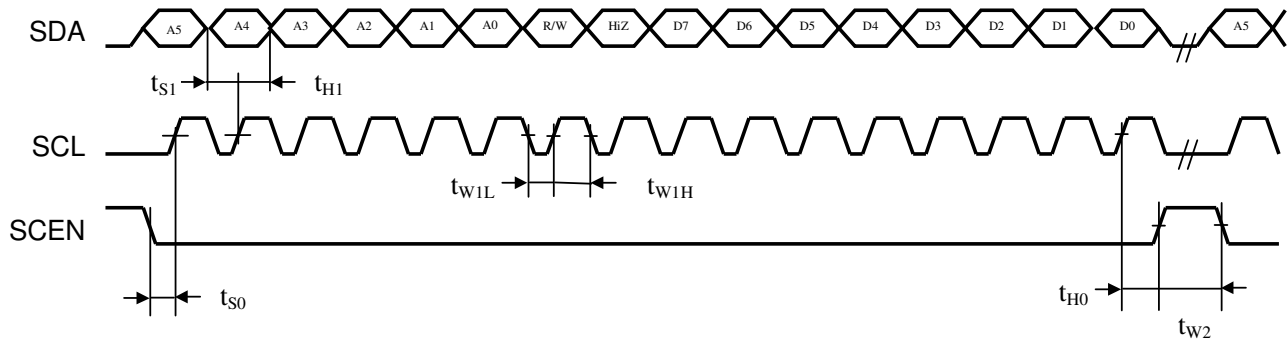

Parameter	Symbol	Condition	MIN	TYP	MAX	Unit
Data Setup Time	t_{S0}	SCEN to SCL	150	-	-	ns
	t_{S1}	SDA to SCL	150	-	-	ns
Data Hold Time	t_{H0}	SCEN to SCL	150	-	-	ns
	t_{H1}	SDA to SCL	150	-	-	ns
Pulse width	t_{W1L}	SCL pulse width	160	-	-	ns
	t_{W1H}	SCL pulse width	160	-	-	ns
	t_{W2}	SCEN pulse width	1.0	-	-	us
Clock Duty	-	SCL duty ratio	40	50	60	%

7. Power Sequence

7.1 Power on to normal mode sequence

Power on (low power mode, global reset) to normal mode sequence.

Step1: Wait VCC go stable and then send a low pulse (more than 160us) to GRSTB pad...

A normal command is following GRSTB low pulse...

Step2: Before turn on VCC, the VD/HD/DCLK input signal must keep still until $T_{pwr}(2ms)$...

Step3: AVDD will start when second VD coming...

Step4: CP_CLK will start when third VD coming...

Step5: Panel Control Signal and Normal DOUT will start when ninth VD coming...

Step6: PWM control signal will start when eleventh VD coming...

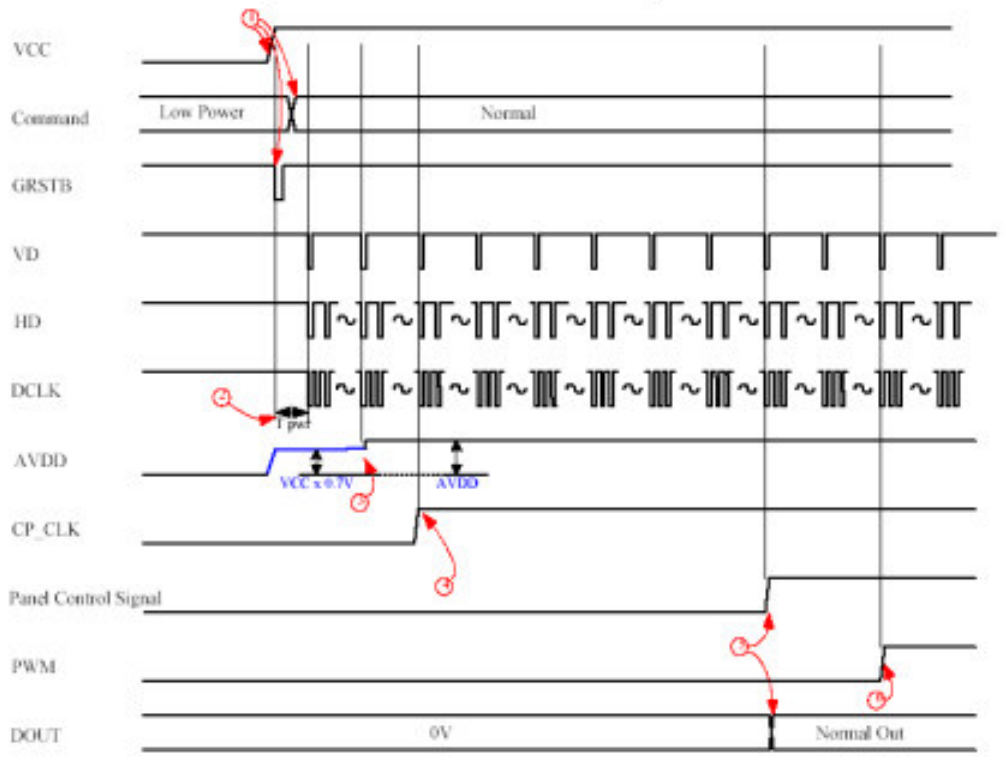

7.2 Normal mode to power off sequence

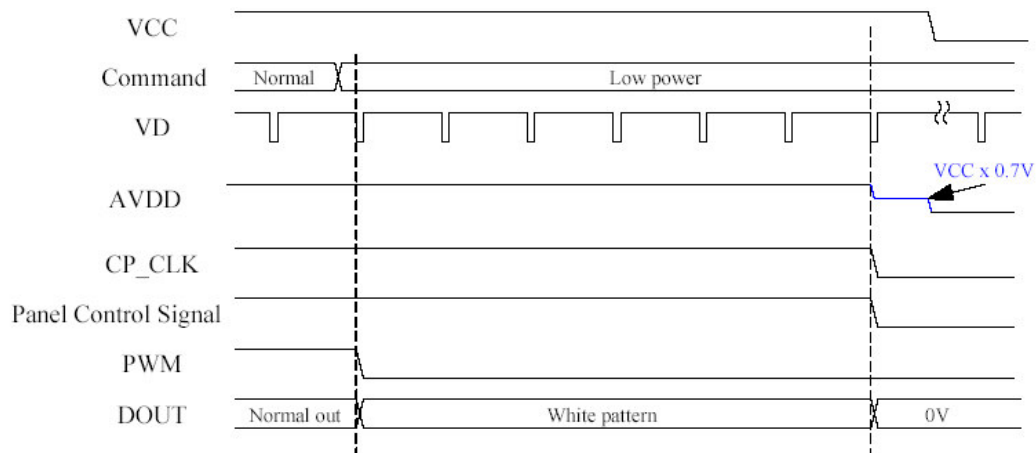

8. OPTICAL CHARACTERISTICS

8.1 Optical Specification

Ta=25°C

Item	Symbol	Condition	MIN	TYP	MAX	Unit	Remarks	
Viewing Angles	$\theta 11$	CR \geq 10	50	60	-	Degree	Note 8-1	
	$\theta 12$		50	60	-			
	$\theta 21$		40	50	-			
	$\theta 22$		50	60	-			
Contrast Ratio	CR	$\theta = 0^\circ$	200	400	-		Note 8-2	
Response Time	Tr + Tf			16	35	ms	Note 8-3	
Luminance (If=23mA)	L		250	300	-	cd/m ²	Note 8-4	
Chromaticity	White		X	0.26	0.31	0.36		Note 8-5
			Y	0.28	0.33	0.38		

8.2 Basic Measure Conditions

(1) Driving voltage

$$VCC = 3\text{ V}$$

(2) Ambient Temperature: Ta=25°C

(3) Testing Point: Measure in the display center point and the test angle $\theta = 0^\circ$

(4) LED Current: If=23mA.

(5) Testing Facility

Environmental illumination: $\leq 1\text{ Lux}$

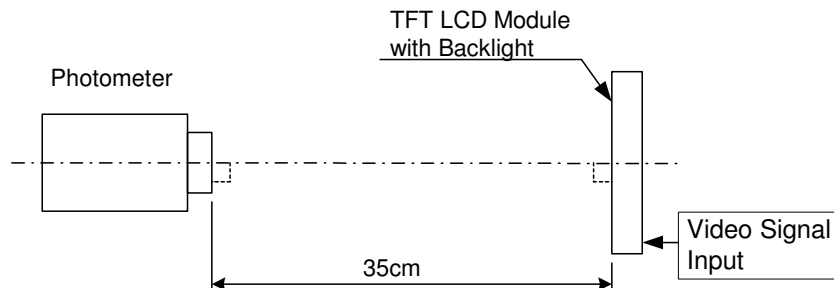

Note 8-1: Viewing angle diagrams:

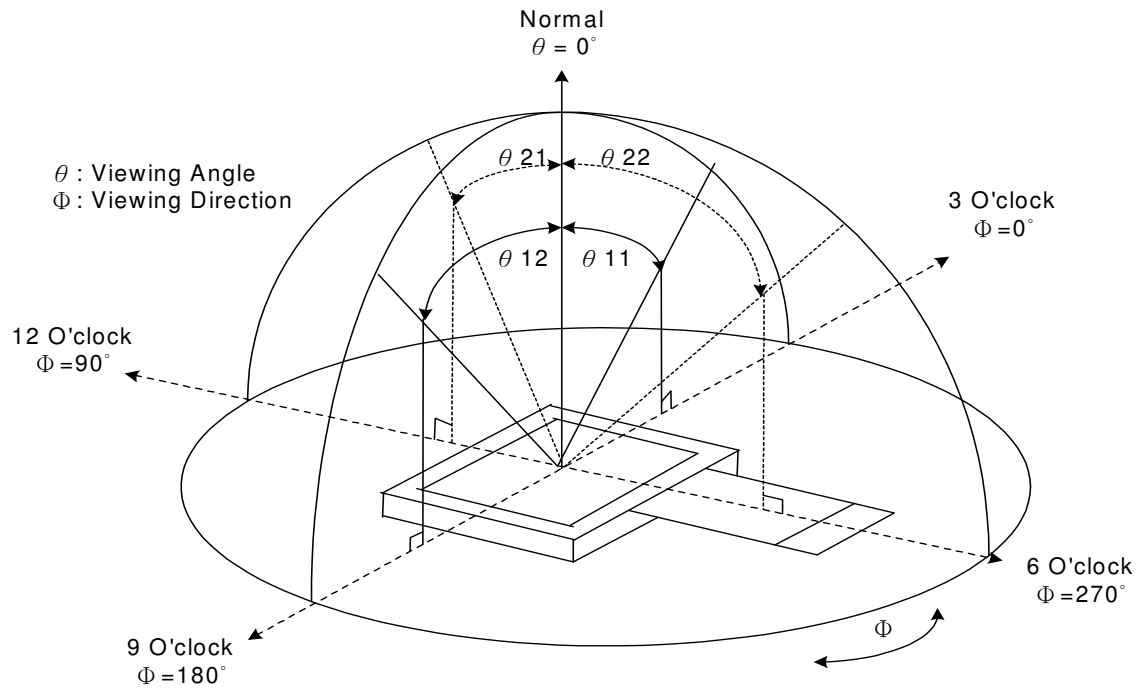

Note 8-2: Contrast Ratio:

Contrast ratio is measured in optimum common electrode voltage.

$$CR = \frac{\text{Luminance with white image}}{\text{Luminance with black image}}$$

Note 8-3: Definition of response time:

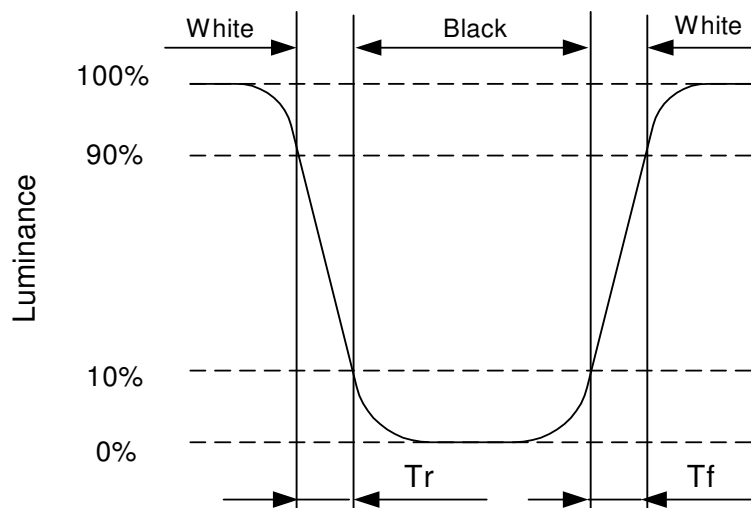

Note 8-4: Luminance:

Test Point: Display Center

Note 8-5: Chromaticity: The same test condition as Note 8-4.

9. RELIABILITY

No	Test Item	Condition
1	High Temperature Operation	Ta=+60°C, 240hrs
2	High Temperature & High Humidity Operation	Ta=+40°C, 95% RH, 240hrs
3	Low Temperature Operation	Ta= 0°C, 240hrs
4	High Temperature Storage (non-operation)	Ta=+80°C, 240hrs
5	Low Temperature Storage (non-operation)	Ta=-30°C, 240hrs
6	Thermal Shock (non-operation)	-30°C \longleftrightarrow 80°C, 50 cycles 30 min 30 min
7	Surface Discharge (non-operation)	C=150pF, R=330Ω; Discharge: Air: ±15kV; Contact: ±8kV 5 times / Point; 5 Points / Panel
8	Vibration (non-operation)	Frequency: 10~55Hz; Amplitude: 1.5mm Sweep Time: 11min Test Time: 2 hrs for each direction of X, Y, Z
9	Shock (non-operation)	Acceleration: 100G; Period: 6ms Directions: ±X, ±Y, ±Z; Cycles: Twice
	Surface pressure test	Surface Pressing points (5 points) Holding time: 30 sec With a smooth diameter 12.7 mm rubber head F=30N without failure

* Ta: Ambient Temperature

10. HANDLING CAUTIONS

10.1 ESD (Electrical Static Discharge) Strategy

ESD will cause serious damage of the panel, ESD strategy is very important in handling. Following items are the recommend ESD strategy

- (1) In handling LCD panel, please wear non-charged material gloves. And the conduction ring connect wrist to the earth and the conducting shoes to the earth is necessary.
- (2) The machine and working table for the panel should have ESD prohibition strategy.
- (3) In handling the panel, ionize flowing decrease the charge in the environment is necessary.
- (4) In the process of assembly the module, shield case should connect to the ground.

10.2 Environment

- (1) Working environment of the panel should in the clean room.
- (2) The front polarizer is easy damaged, handle it carefully and do not scratch it by sharp material.
- (3) Panel has polarizer protective film in the surface please remove the protection film of polarizer slowly with ionized air to prevent the electrostatic discharge.

10.3 Others

- (1) Turn off the power supply before connecting and disconnecting signal input cable.
- (2) The connection area of FPC and panel is very weak, do not handle panel only by FPC or bend FPC.
- (3) Water drop on the surface or condensation as panel power on will corrode panel electrode.
- (4) As the packing bag open, watch out the environment of the panel storage. High temperature and high humidity environment is prohibited.
- (5) When the TFT LCD module is broken, please watch out whether liquid crystal leaks out or not. If your hand touches liquid crystal, wash your hand cleanly by water and soap as soon as possible.

11. MECHANICAL DRAWING

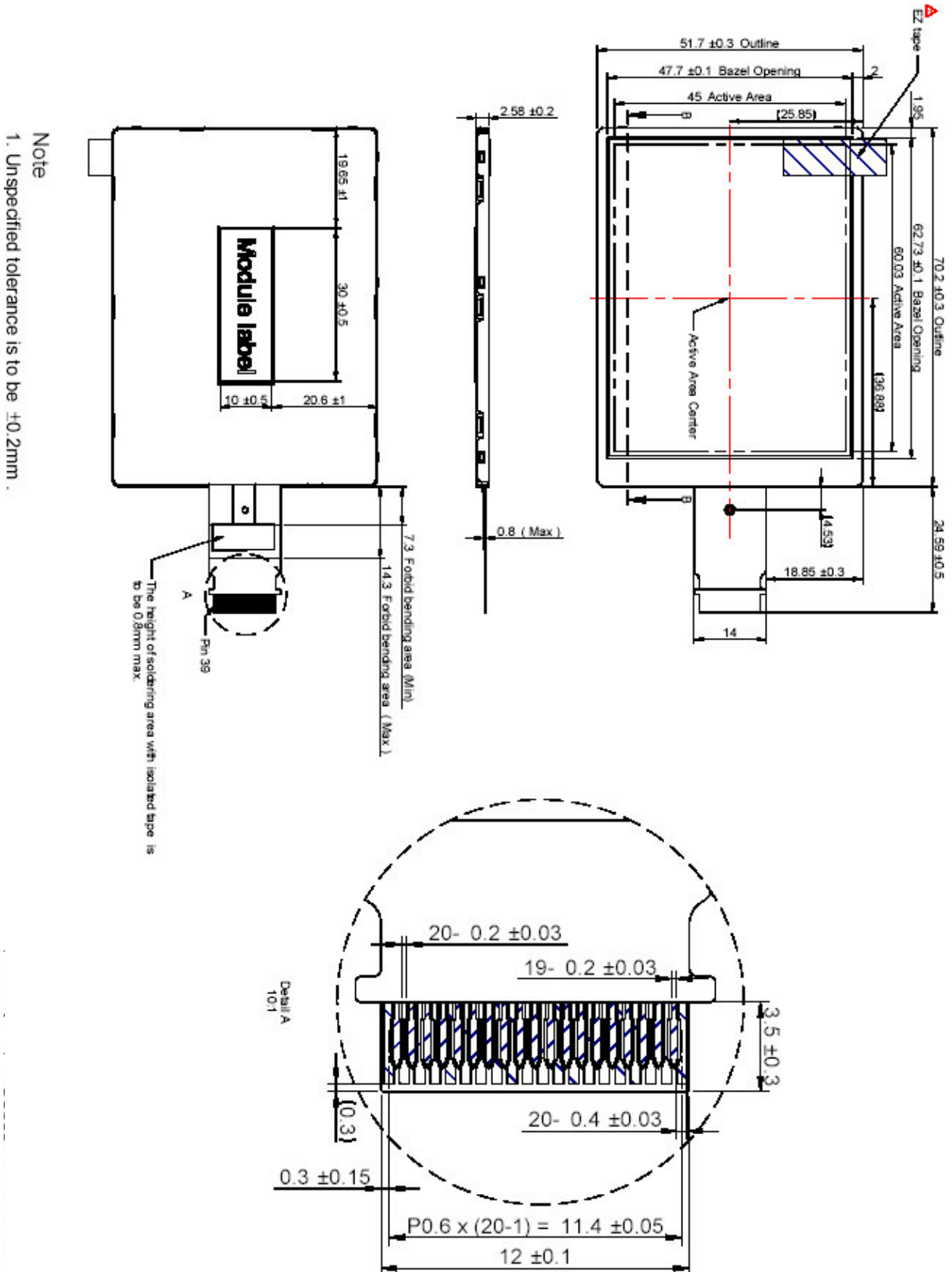

The information contained herein is the exclusive property of toppoly Optoelectronics corporation, and shall not be distributed, reproduced, or disclosed in whole or in part without prior written permission of toppoly Optoelectronics corporation.

12. PACKING DRAWING

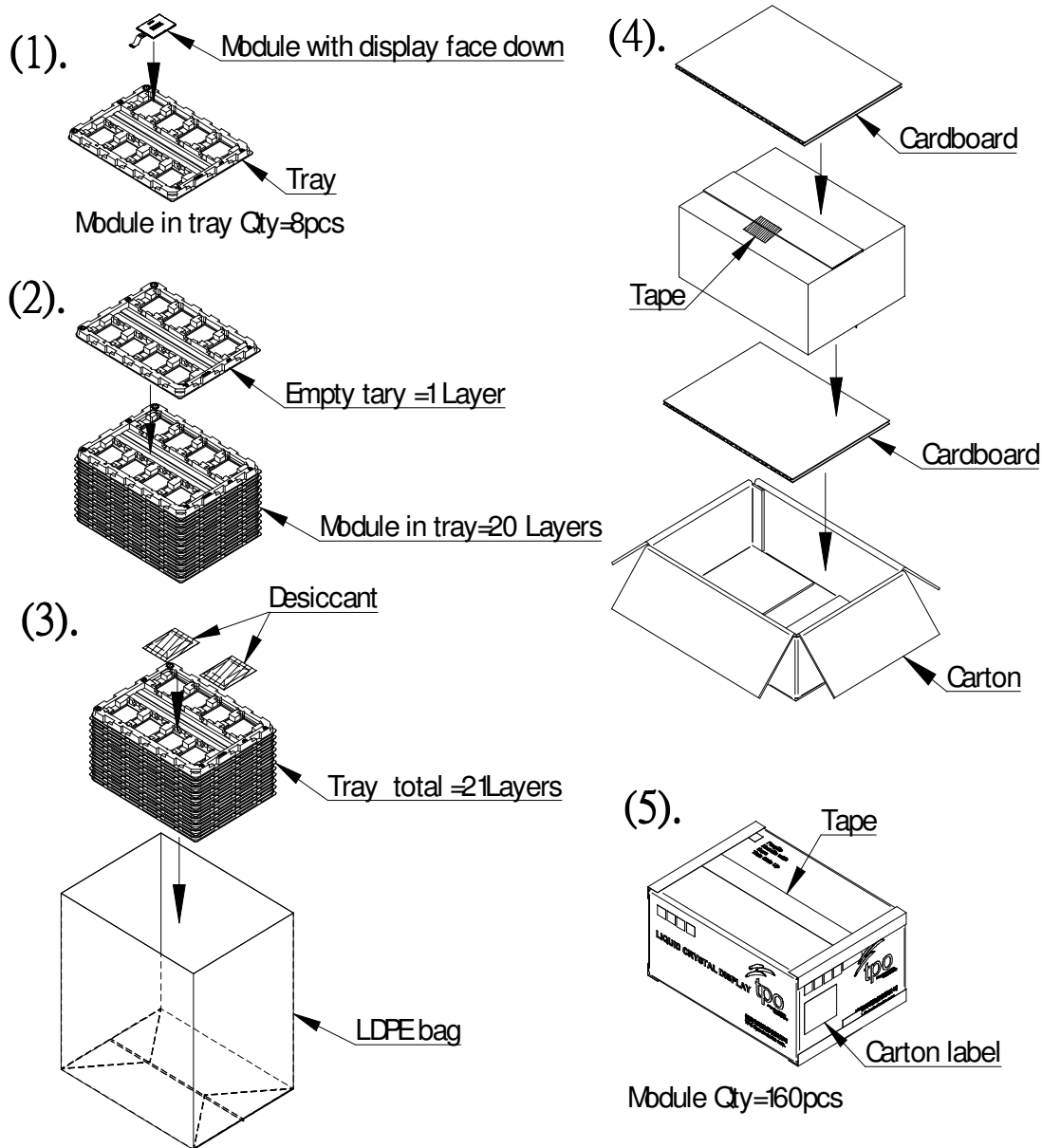

3.0" module (TD030WHEA1) delivery packing method

- (1). Module packed into tray cavity (with module display face down).
- (2). Tray stacking with 20 layers and with 1 empty tray above the stacking tray unit.
2pcs desiccant put above the empty tray
- (3). Stacking tray unit put into the LDPE bag and fix by adhesive tape.
- (4). Put 1pc cardboard inside the carton bottom, and then pack the package unit into the carton. Put 1pc cardboard above the package unit.
- (5). Carton tapping with adhesive tape.