

LTPS LCD Specification

Model Name: TD043MTEA1

Customer Signature
Date

This technical specification is subjected to change without notice

Table of Contents

RECORD REVISION.....	3
FEATURES	4
GENERAL SPECIFICATIONS	4
INPUT/OUTPUT TERMINALS.....	5
1. TFT LCD Panel.....	5
2. Application circuit :.....	9
3. Power ON sequence	11
4. Power OFF sequence.....	12
ABSOLUTE MAXIMUM RATINGS	13
ELECTRICAL CHARACTERISTICS.....	14
1. Driving TFT LCD Panel.....	14
2. Driving Backlight.....	14
TIMING CHART	15
OPTICAL CHARACTERISTICS	17
1. Optical Specification.....	17
2. Basic Measure Conditions	17
RELIABILITY	20
HANDLING CAUTIONS	21
1. ESD (Electrical Static Discharge) Strategy	21
2. Environment.....	21
3. Others	21
MECHANICAL DRAWING	22
PACKING DRAWING	23

RECORD REVISION

Rev	Issued Date	Description
0.10	Aug. 21, 2006	Page 9: Modify application circuit
0.11	Aug. 24, 2006	Page 9: Modify application circuit
0.12	Oct. 31, 2006	Page 12: Rectify the data of input horizontal timing Page 13: Rectify the data of input vertical timing
0.13	Dec. 07, 2006	Page 12, 13: Correct DENB label to DEN
0.14	Apr. 19, 2007	Page 14: Optical characteristics
0.15	Apr. 20, 2007	Page 15: Definition of response time
0.16	May. 08, 2007	Page 11: Modify Panel Power Consumption
0.17	May. 15, 2007	Page 19: Mechanical drawing Page 15: Uniformity of optical specification
0.18	May. 28, 2007	Page 5,6: Update input/output terminals Page 9: Update the application circuit Page 11: Update absolute maximum ratings Page 12: Update electrical characteristics
0.19	May. 30, 2007	Page 15: Optical characteristics
0.20	Jun. 11, 2007	Add Power on/off sequence

FEATURES

The 4.3" LCD module is the active matrix color TFT LCD module. LTPS (Low Temperature Poly Silicon) TFT technology is applied with vertical and horizontal drivers built on the panel.

Both of horizontal and vertical scan are reversible and controlled by the serial interface commands.

The product is designed for the requirement of the green product, and the specification complies with TPO's "Green Product Chemical Substance Specification Standard Hand Book".

GENERAL SPECIFICATIONS

Item	Description	Unit
Display Size (Diagonal)	4.3	Inch
Aspect ratio	15:9	-
Display Type	Transmissive	-
Active Area (HxV)	93.6 x 56.16	mm
Number of Dots (HxV)	800 x RGB x480	Dot
Dot Pitch (HxV)	0.039 x 0.117	mm
Color Arrangement	Stripe	-
Color Numbers	16Million	-
Outline Dimension (HxVxT) *	100.6x68.45x4.1	mm
Weight	TBD	G

*Exclude FPC and protrusions.

INPUT/OUTPUT TERMINALS

1. TFT LCD Panel

Recommend connector: FH28-60S-0.5SH(51)

Pin	Symbol	I/O	Description	Remark
1	T1	D	Only for TPO test pin	
2	CGH	C	Capacitor for VGH(+8.5 V)(1 uF)	
3	CPL1	C	Capacitor for charge pump clock (0.2 uF)	
4	CPL2	C	Capacitor for charge pump clock (0.2 uF)	
5	VCOM	C	Capacitor for VCOM (2.2 uF)	
6	VD	I	Vertical sync input	
7	HD	I	Horizontal sync input	
8	DEN	I	Data Enable	
9	NCLK	I	Clock signal, latch data onto line latches	
10	B0	I	Blue data (LSB)	
11	B1	I	Blue data	
12	B2	I	Blue data	
13	B3	I	Blue data	
14	B4	I	Blue data	
15	B5	I	Blue data	
16	B6	I	Blue data	
17	B7	I	Blue data (MSB)	
18	GND	P	Ground	
19	G0	I	Green data (LSB)	
20	G1	I	Green data	
21	G2	I	Green data	
22	G3	I	Green data	
23	G4	I	Green data	
24	G5	I	Green data	
25	G6	I	Green data	
26	G7	I	Green data (MSB)	
27	VCC	P	Power supply (3.3 V) for digital circuit	
28	R0	I	Red data (LSB)	
29	R1	I	Red data	
30	R2	I	Red data	
31	R3	I	Red data	
32	R4	I	Red data	

33	R5	I	Red data	
34	R6	I	Red data	
35	R7	I	Red data (MSB)	
36	VDDP	P	+5 V power supply for analog circuit	
37	VSS	P	Ground	
38	VDDN	P	-5 V power supply for analog circuit	
39	HVDE	I	Mode selection pin. HVDE="H" for SYNC(use HD +VD) mode, HVDE="L" for DE(use DEN) mode.	
40	GREST	I	Global reset pin	
41	STBY	I	Standby mode setting pin	
42	SCEN	I	Serial interface chip enable line	
43	SCL	I	Serial interface clock line	
44	SDA	I/O	Serial interface data line	
45	VCC	P	Power supply (3.3 V) for digital circuit	
46	FB	I	Main boost regulator feedback input(default:disable)	
47	GND	P	Ground	
48	VMP	C	Capacitor for +1.8 V power supply (2.2 uF)	
49	VMN	C	Capacitor for -1.8 V power supply (2.2 uF)	
50	C11	C	Capacitor for charge pump (DC/DC) circuit (1 uF)	
51	C12	C	Capacitor for charge pump (DC/DC) circuit (1 uF)	
52	CGL	C	Capacitor for VGL(-6.5V) (0.1 uF)	
53	Y_UP	I	For Touch panel Y_UP	Note 2
54	X_LEFT	I	For Touch panel X_LEFT	
55	Y_BOTTOM	I	For Touch panel Y_BOTTOM	
56	X_RIGHT	I	For Touch panel X_RIGHT	
57	LED A+	P	LEDA power: anode (no use)	Note 1
58	LED B+	P	LEDB power: anode	
59	LED B-	P	LEDB power: cathode	
60	LED A-	P	LEDA power: cathode (no use)	

I : Input O: Output P: Power C: Capacitor D: Dummy I/O : Input/Output

Note 1: The figure below shows the connection of backlight LED

Note 2: The figure below shows the connection of Touch panel.

Note 1: LEDA+ , LEDA- no use

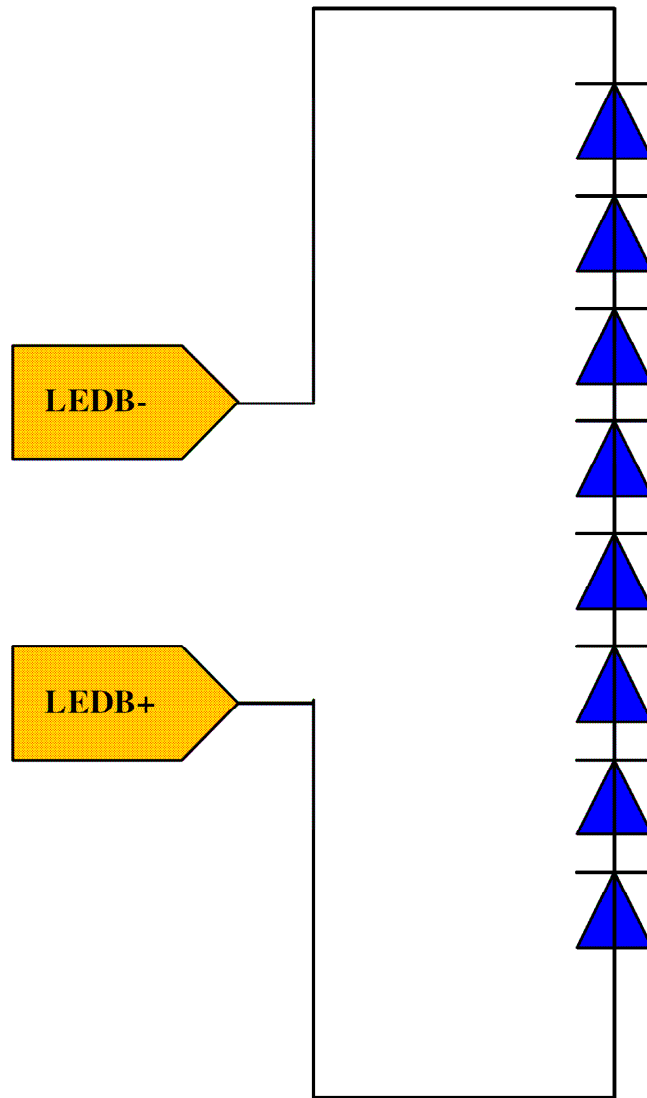

TOP VIEW

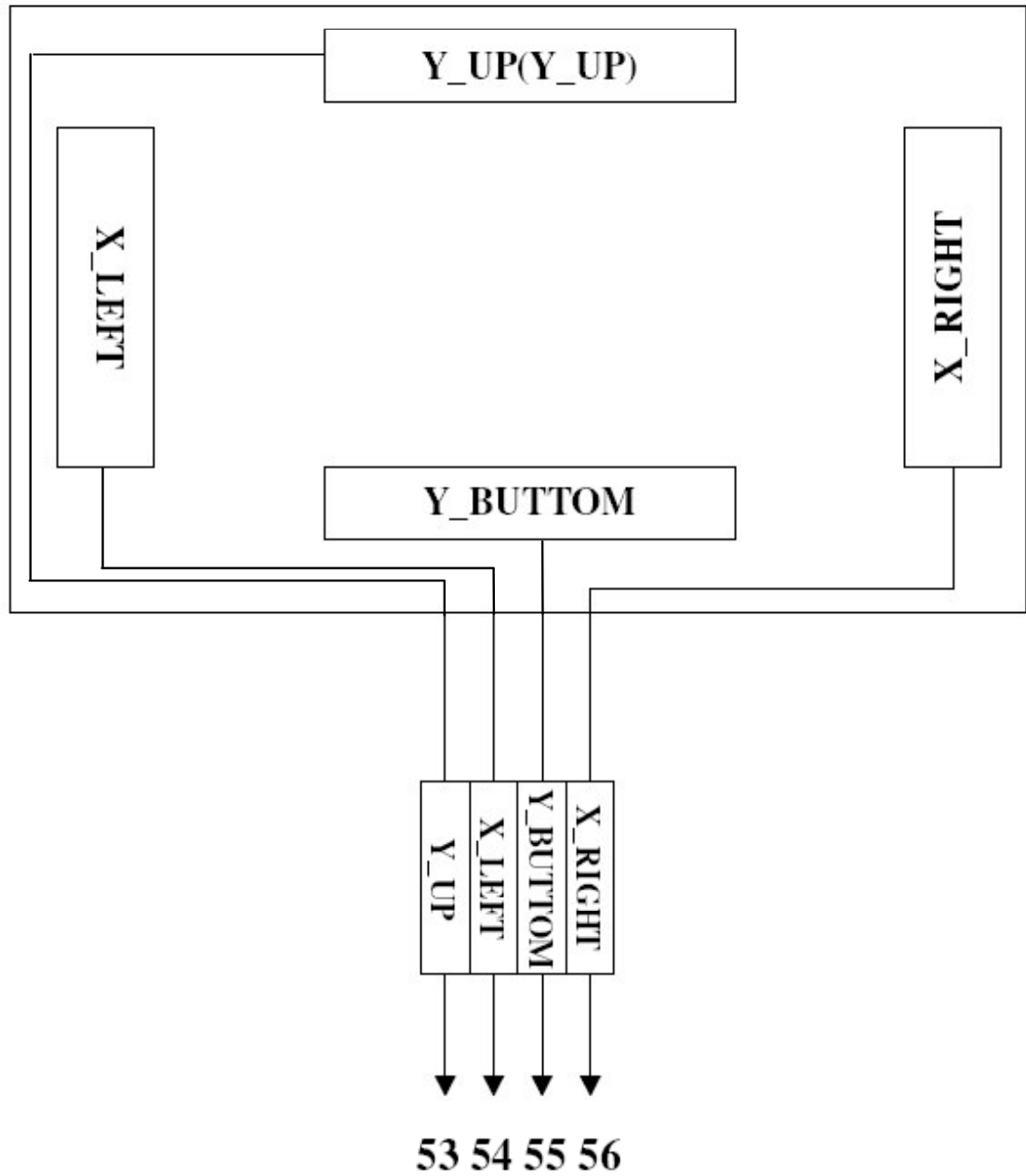

2. Application circuit :

For LCD module

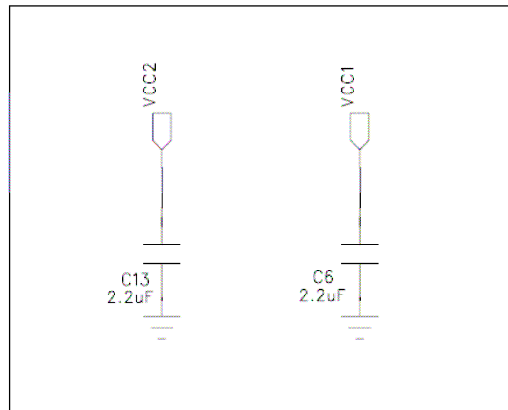
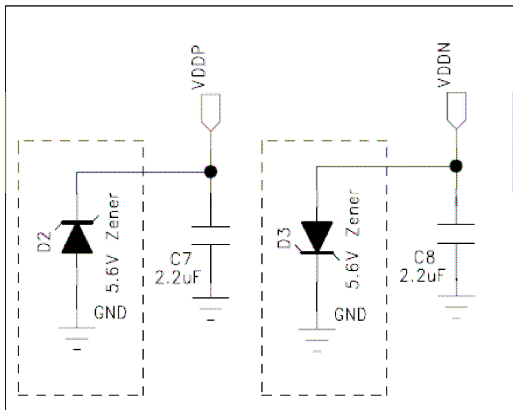
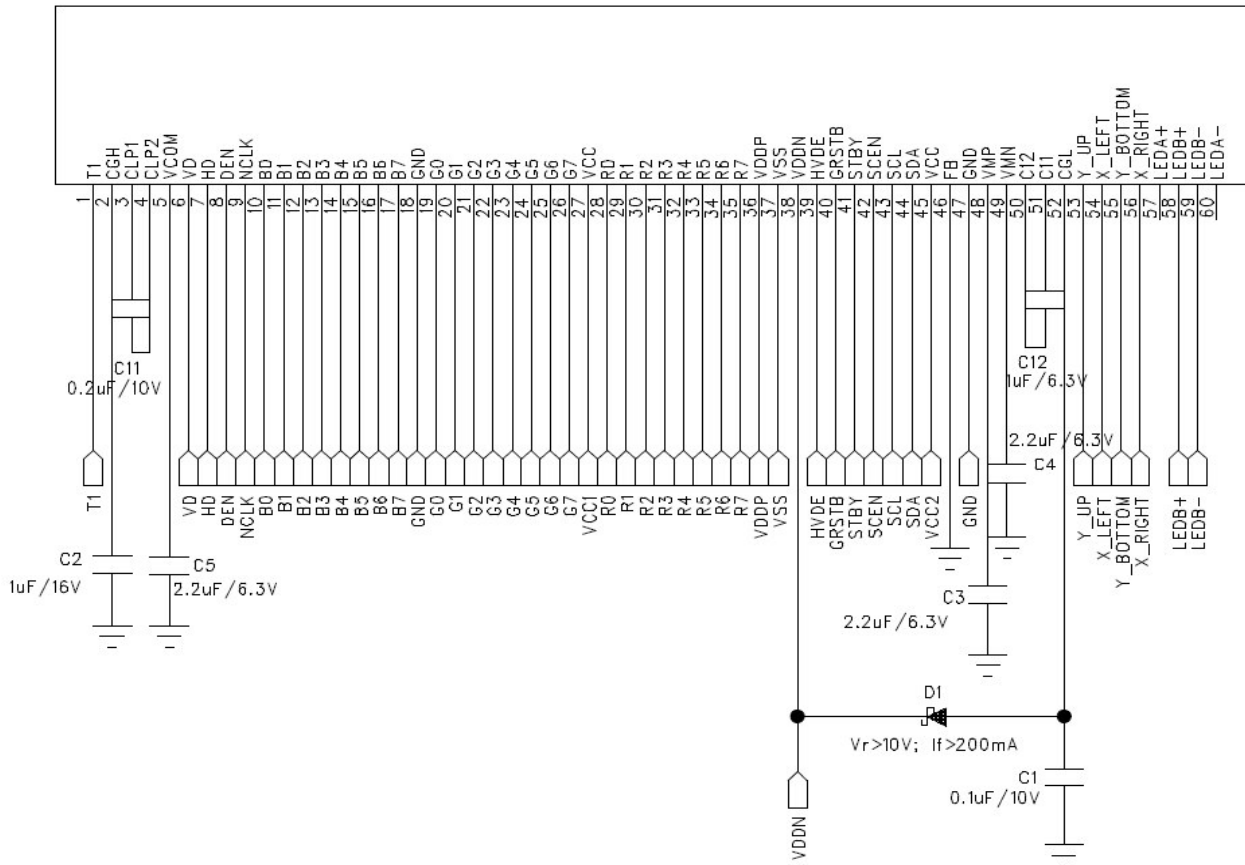

Recommendable Zener-Diode : PANJIT - BZT52 B5V6S

The Zener diode is used for protecting the voltage damping, spike or unclear power (have large noise etc.) to break down the driver IC on LCD module. If the LCD user can guarantee the voltage range of VDDP and VDDN will always lie in spec definition (please refer the ELECTRICAL CHARACTERISTICS). The Zener-Diode is not necessary.

For LED backlight driver

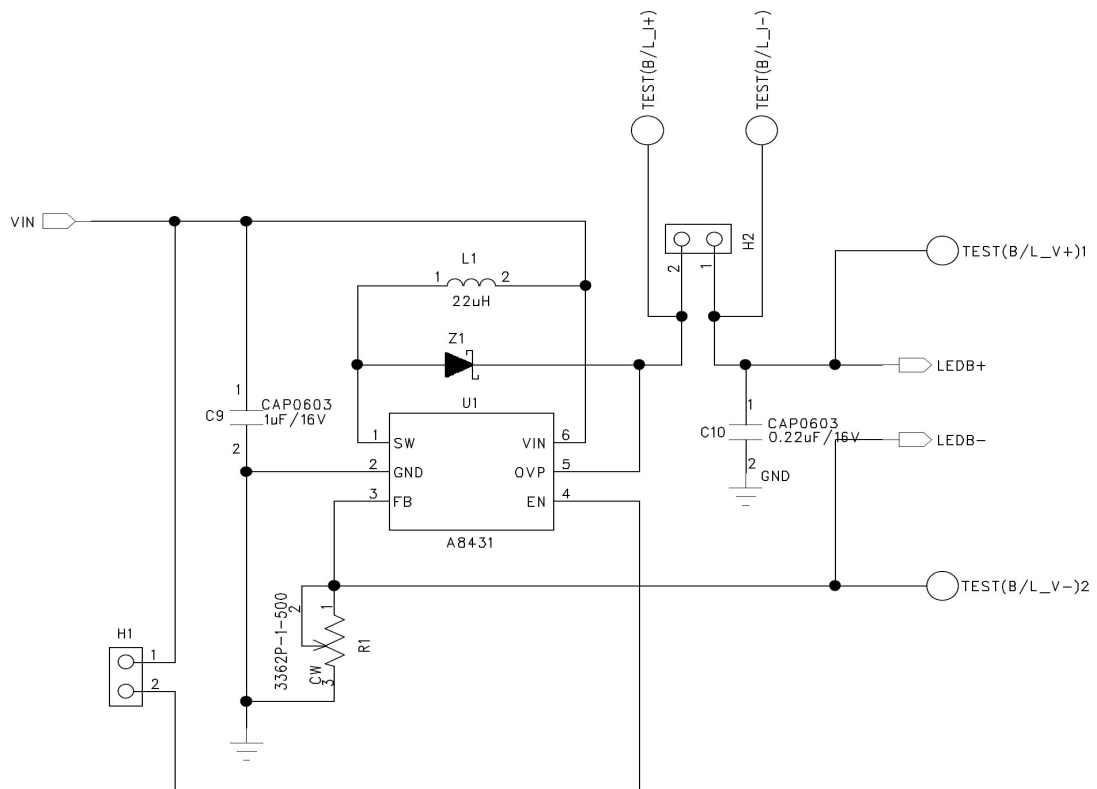

3. Power ON sequence

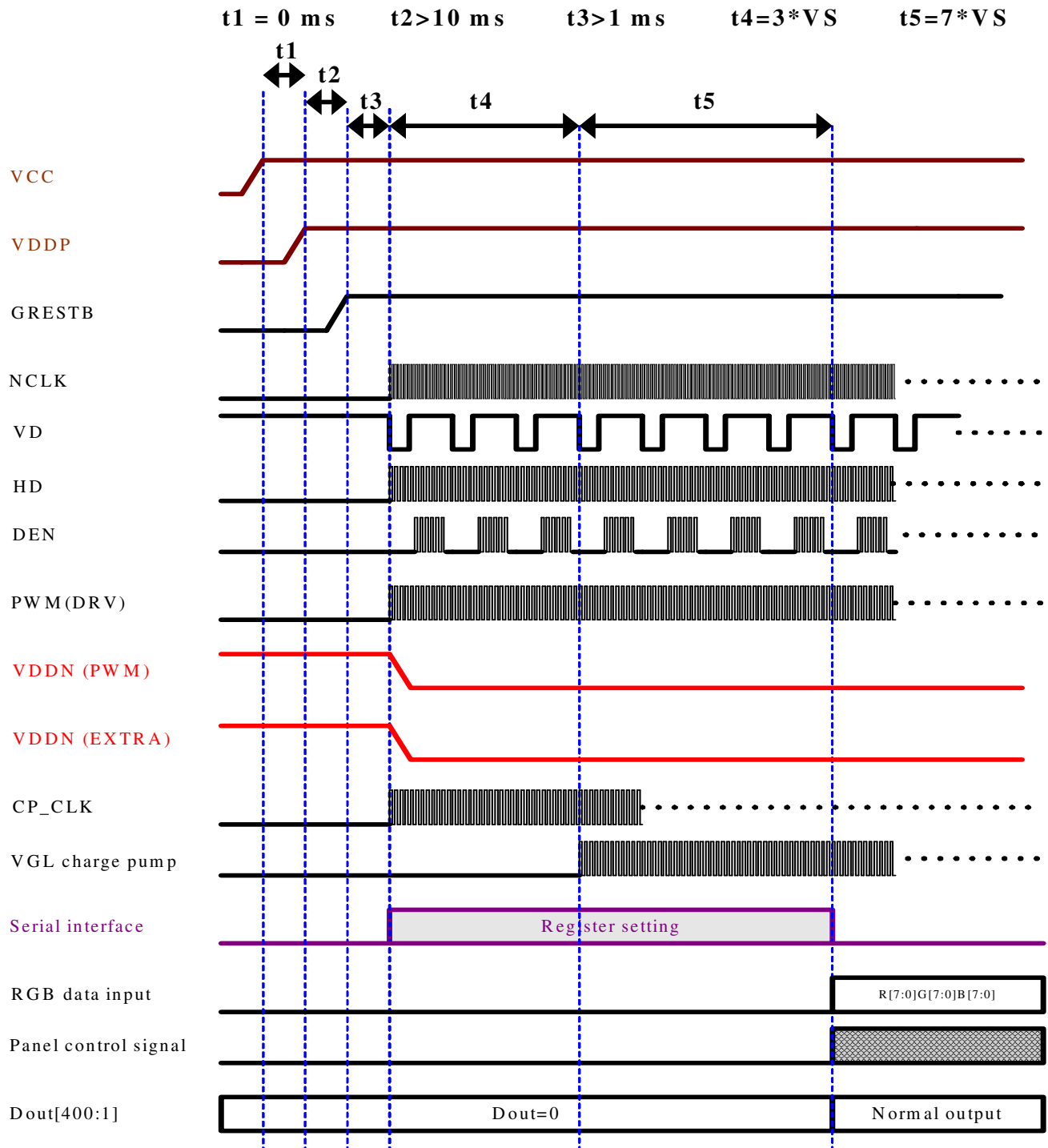

Notice : For VDDP, HI=5V and LOW=0V. For VDDN, HI=0V and LOW= -5V

4. Power OFF sequence

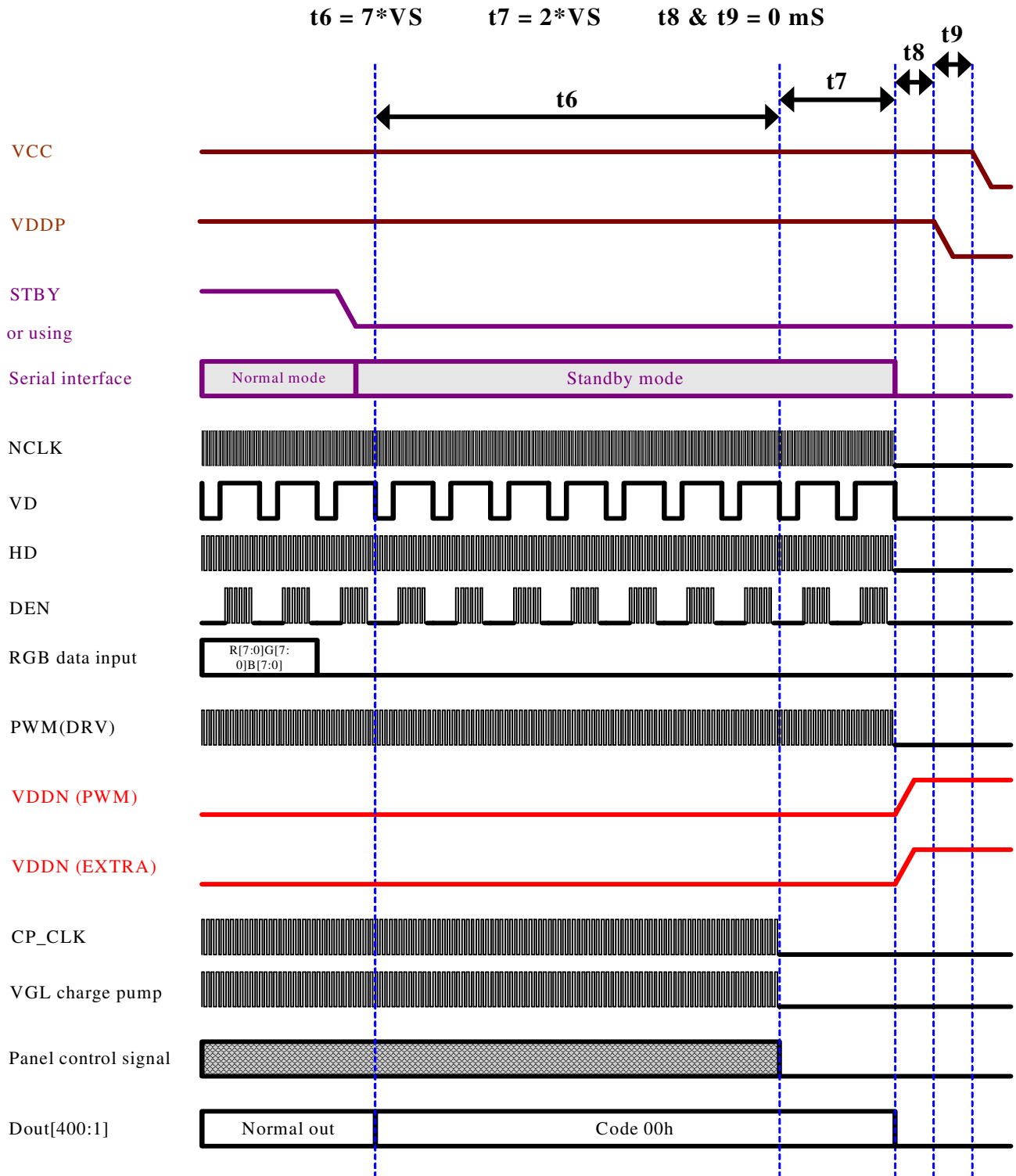

Notice : For VDDP, HI=5V and LOW=0V. For VDDN, HI=0V and LOW= -5V

ABSOLUTE MAXIMUM RATINGS

Ta = 25°C

Item	Symbol	MIN	MAX	Unit	Remark
Digital Power Supply Voltage	VCC	-0.5	5.0	V	
Analog Power Supply Voltage (positive)	VDDP	-0.5	5.5	V	
Analog Power Supply Voltage (negative)	VDDN	-5.5	0.5	V	
Logic input voltage	V _{IN1}	-0.3	VCC+0.3	V	VD, HD, DEN, NCLK, R[7:0], G[7:0], B[7:0], SDA, SCL, SCEN, STBY, GRSTB, HVDE
Back Light Forward Current	I _F	18	23	mA	
Operating Temperature	T _{OPR}	-20	+70	°C	
Storage Temperature	T _{STG}	-40	+85	°C	

Please ensure that the power supply voltage (Digital & Analog) does not exceed the absolute maximum rating **in any condition** when the LCD module is operating. Or the driver IC on the LCD module can be broken.

ELECTRICAL CHARACTERISTICS

1. Driving TFT LCD Panel

GND=0V, Ta=25°C

Item	Symbol	MIN	TYP	MAX	Unit	Remark
Power Supply Voltage	VCC	2.7	3.3	3.6	V	
	VDDP	4.5	5.0	5.5	V	
	VDDN	-5.5	-5	-4.5	V	
Input Signal Voltage	Low Level V _{IL}	GND	-	0.2x VCC*	V	VD, HD, DEN, NCLK, R[7:0], G[7:0], B[7:0], SDA, SCL, SCEN, STBY, GRSTB, HVDE
	High Level V _{IH}	0.8x VCC*	-	VCC*	V	
Panel Power Consumption	W _P	-	120	150	mW	Base on 800RGBx480

VCC* =VCC (TYP)

2. Driving Backlight

Ta=25°C

Item	Symbol	MIN	TYP	MAX	Unit	Remark
Forward Current	I _f	18	20	23	mA	
Forward Current Voltage	V _f	-	26.4	29.6	V	
Backlight Power Consumption	W _{BL}	-	528	680.8	mW	

Backlight driving circuit is recommend as the fix current circuit.

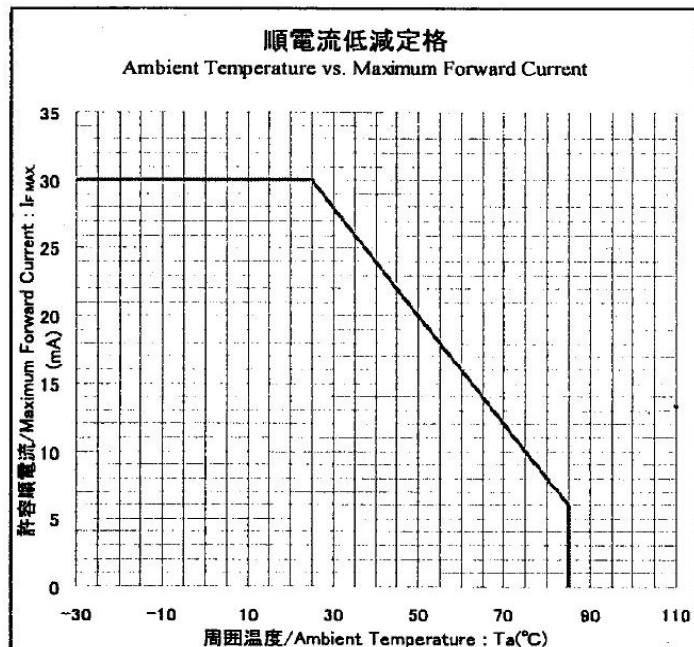

TIMING CHART

<Input timing >

--Horizontal--

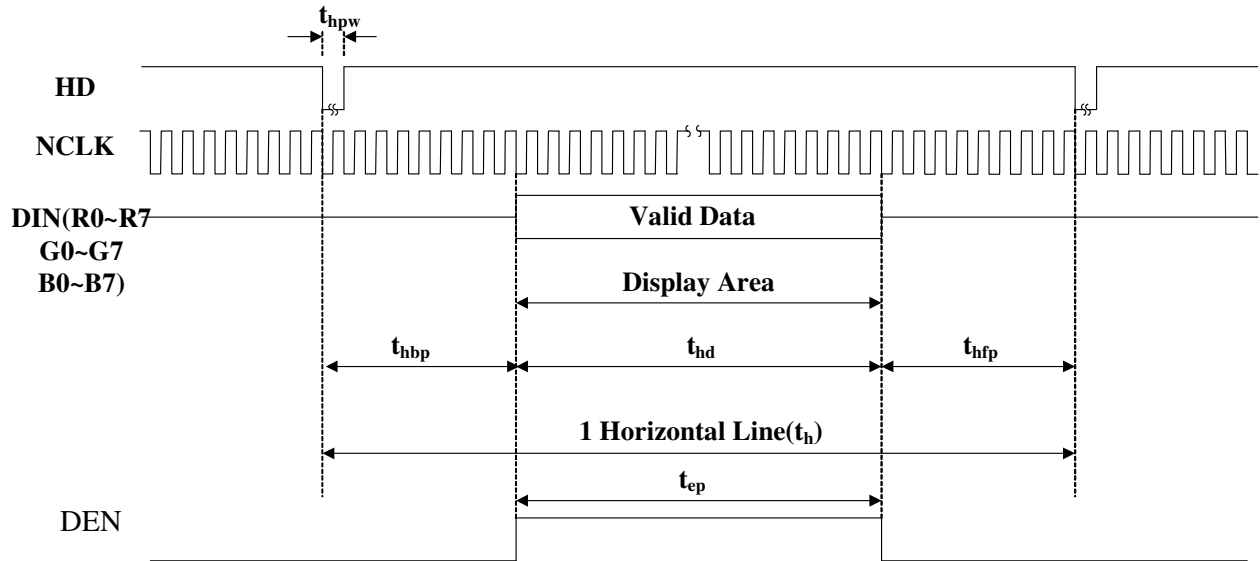

Horizontal Input Data

Parameter		Symbol	800RGBx480	480RGBx272	400RGBx240	Unit
NCLK Frequency		F_{NCLK}	33.2	9	8.3	MHz
Horizontal valid data		t_{hd}	800	480	400	NCLK
1 Horizontal Line		t_h	1056	525	528	NCLK
HSYNC Pulse Width	Min.	t_{hpw}	1	1	1	NCLK
	Typ.					
	Max.					
Hsync blanking		t_{hbp}	216	43	108	NCLK
Hsync front porch		t_{hfp}	40	2	20	NCLK
DEN Enable Time		t_{ep}	800	480	400	NCLK

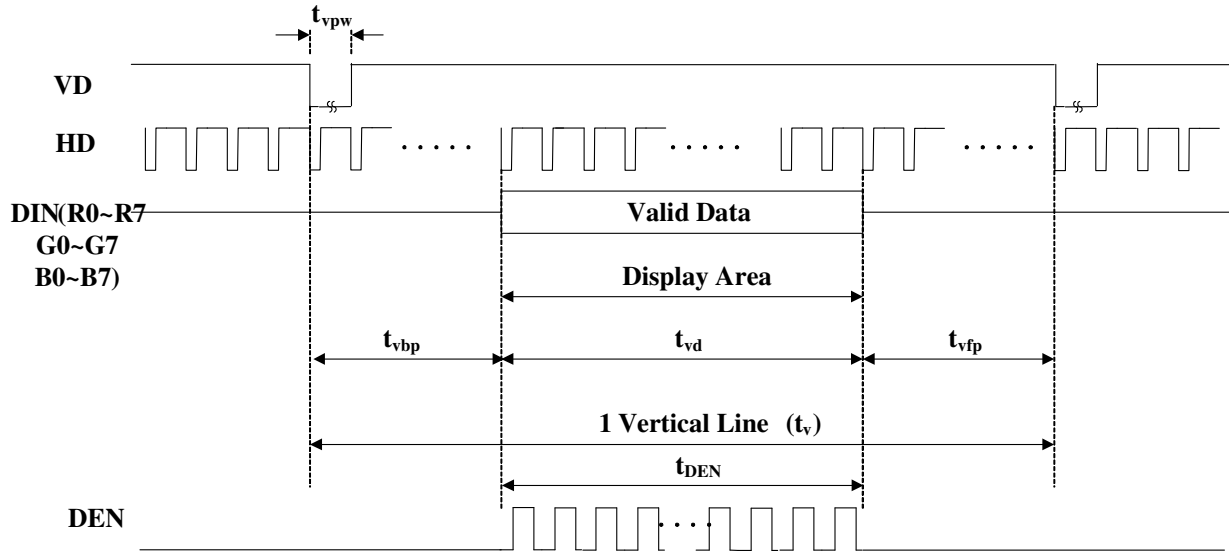

Parameter		Symbol	800RGBx480	480RGBx272	400RGBx240	Unit
Vertical valid data		t_{vd}	480	272	240	H
Vertical period		t_v	525	286	262	H
VSYNC Pulse Width	Min.	t_{vpw}	1	1	1	H
	Typ.					
	Max.					
Vertical back porch		t_{vbp}	35	12	20	H
Vertical front porch		t_{vfp}	10	2	2	H
Vertical blanking of DEN mode		t_{vb}	45	14	22	H
Total DEN in VD		t_{DEN}	480	272	240	H

DEN mode (The DEN signal can instead of HD and VD signals for ASIC to identify the input data)

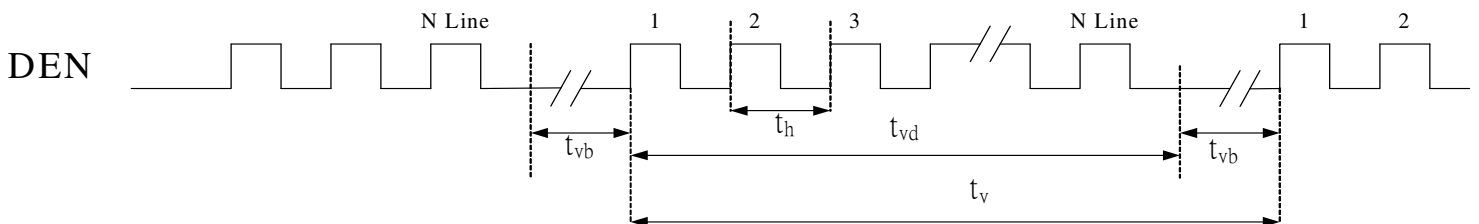

OPTICAL CHARACTERISTICS

1. Optical Specification

Ta=25°C

Item	Symbol	Condition	MIN	TYP	MAX	Unit	Remarks
Viewing Angles	$\theta_{11} + \theta_{12}$	CR \geq 10	150	170	-	Degree	Note 7-1
	$\theta_{21} + \theta_{22}$		150	170	-		
Contrast Ratio		CR	280	400	-		Note 7-2
Response Time	Rising+Falling	Tr + Tf	-	30	-	ms	Note 7-3
Luminance (I _F =20mA)		L	250	300	-	cd/m ²	Note 7-4
Uniformity		-	75	80	-	%	Note 7-6
Chromaticity	White	x _w	0.26	0.31	0.36		Note 7-5
		y _w	0.28	0.33	0.38		

2. Basic Measure Conditions

(1) Driving voltage

$$V_{CC} = 3\text{ V}$$

(2) Ambient Temperature: Ta=25°C

(3) Testing Point: Measure in the display center point and the test angle $\theta = 0^\circ$

(4) LED Current: I_F=20mA.

(5) Testing Facility

Environmental illumination: $\leq 1\text{ Lux}$

Measure System : BM7

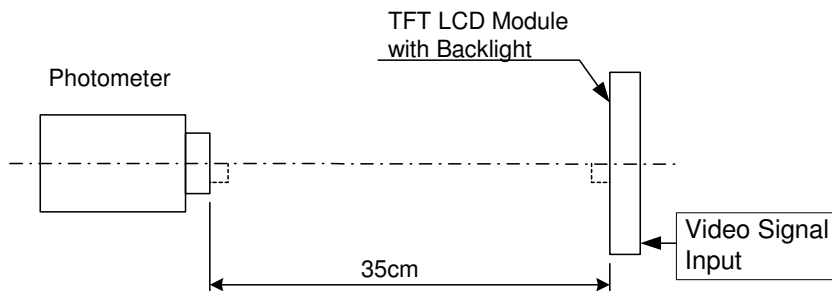

Note 7-1: Viewing angle diagrams:

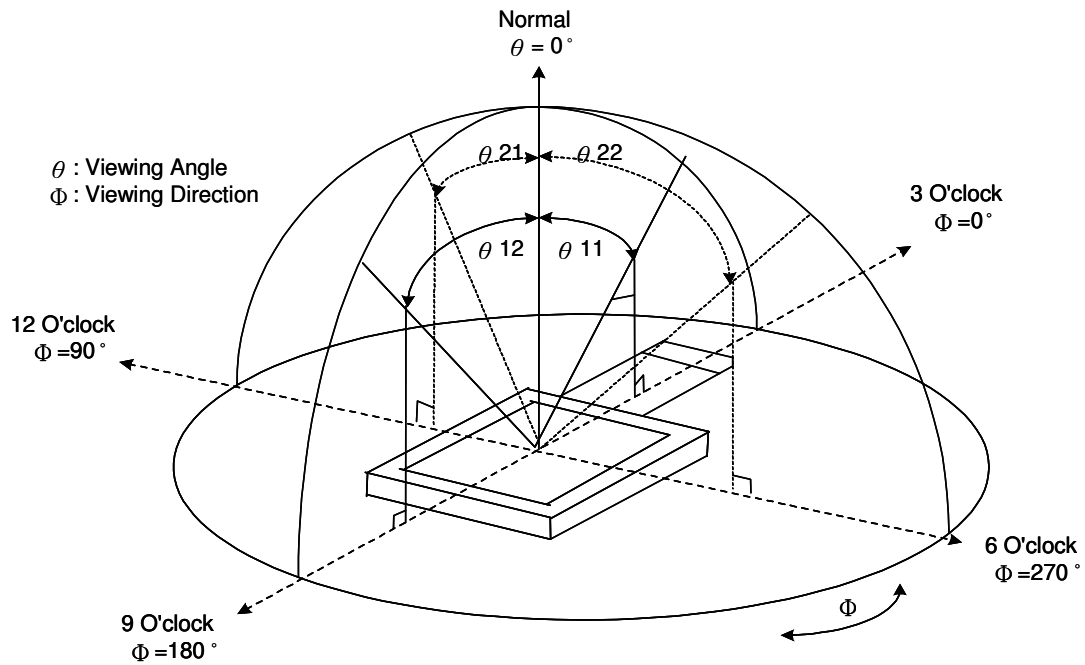

Note 7-2: Contrast Ratio:

Contrast ratio is measured in optimum common electrode voltage.

$$CR = \frac{\text{Luminance with white image}}{\text{Luminance with black image}}$$

Note 7-3: Definition of response time:

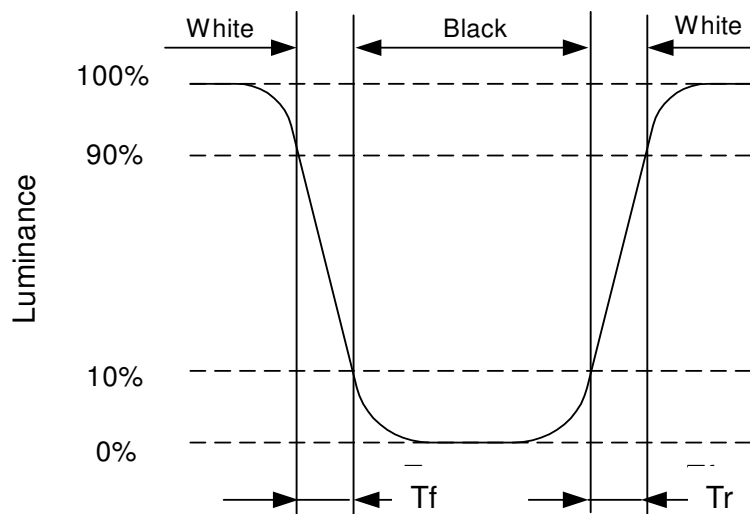

Note 7-4: Luminance:

Test Point: Display Center

Note 7-5: Chromaticity: The same test condition as Note 7-4.

Note 7-6: Uniformity (Measure System BM7)

The luminance of 9 points as the black dot in the figure shown below are measured and the uniformity is defined as the formula:

$$\text{Uniformity} = \frac{\text{The minimum luminance among 9 points}}{\text{The maximum luminance among 9 points}}$$

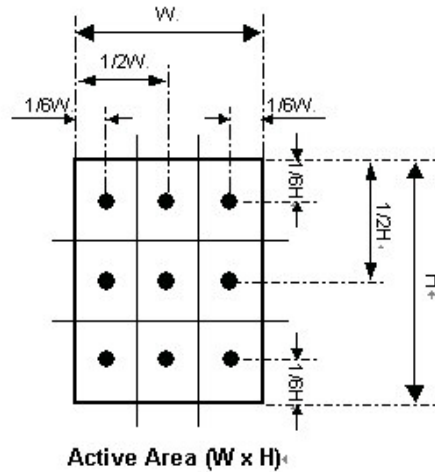

RELIABILITY

No	Test Item	Condition
1	High Temperature Operation	Ta=+70°C, 240hrs
2	High Temperature & High Humidity Operation	Ta=+40°C, 95%RH, 240hrs
3	Low Temperature Operation	Ta=-20°C, 240hrs
4	High Temperature Storage (non-operation)	Ta=+85°C, 240hrs
5	Low Temperature Storage (non-operation)	Ta=-40°C, 240hrs
6	Thermal Shock (non-operation)	-30°C <-- --> +70°C, 50 cycles, (30 min) (30 min)
7	Surface Discharge (non-operation)	C=150pF, R=330 ohm; Discharge: Air: +/-15kV; Contact: +/-8kV 5 times/Point; 5 points/ Panel
8	Vibration (non-operation)	Frequency: 10~55Hz; Amplitude: 1.5mm Sweet Time: 11min Test Time: 2hrs for each direction of X,Y,Z
9	Shock (non-operation)	Acceleration: 100G; Period: 6ms Directions: +/-X; +/-Y; +/-Z; Cycles: Once
10	Pin Activation Test (Touch Panel)	Hit 1000000 times with a silicon rubber of R8 HS60 Hitting Force: 250g Hitting Speed: 3 time/sec.
11	Writing Friction Resistance Test (Touch Panel)	Pen: 0.8R Polyacetal stylus Load: 250g Speed: 3 strokes/sec Stroke: 35mm 100000 times.

Ta: Ambient Temperature,

HANDLING CAUTIONS

1. ESD (Electrical Static Discharge) Strategy

ESD will cause serious damage of the panel, ESD strategy is very important in handling. Following items are the recommend ESD strategy

- (1) In handling LCD panel, please wear non-charged material gloves. And the conduction ring connect wrist to the earth and the conducting shoes to the earth is necessary.
- (2) The machine and working table for the panel should have ESD prohibition strategy.
- (3) In handling the panel, ionize flowing decrease the charge in the environment is necessary.
- (4) In the process of assembly the module, shield case should connect to the ground.

2. Environment

- (1) Working environment of the panel should in the clean room.
- (2) The front polarizer is easy damaged, handle it carefully and do not scratch it by sharp material.
- (3) Panel has polarizer protective film in the surface please remove the protection film of polarizer slowly with ionized air to prevent the electrostatic discharge.

3. Others

- (1) Turn off the power supply before connecting and disconnecting signal input cable.
- (2) The connection area of FPC and panel is very weak, do not handle panel only by FPC or bend FPC.
- (3) Water drop on the surface or condensation as panel power on will corrode panel electrode.
- (4) As the packing bag open, watch out the environment of the panel storage. High temperature and high humidity environment is prohibited.
- (5) When the TFT LCD module is broken, please watch out whether liquid crystal leaks out or not. If your hand touches liquid crystal, wash your hand cleanly by water and soap as soon as possible.

MECHANICAL DRAWING

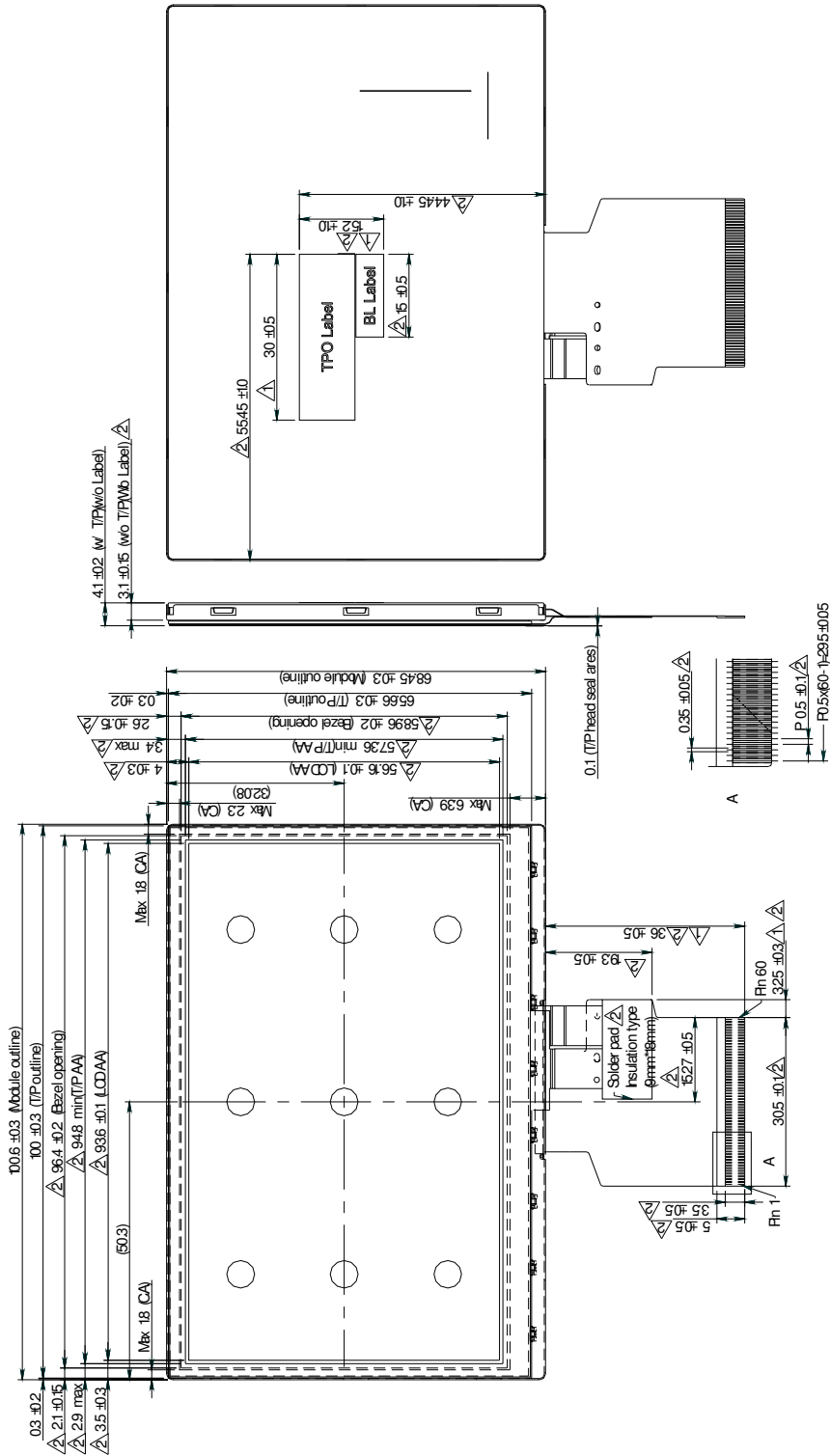

Note:
1. Please design the bezel not to contact with T/P Upper Electrode film. Otherwise, T/P may input in correctly by giving the force to the bezel, and We recommend used the bezel material which is hard to bend.
2. Please design the bezel cushion with in Cushion area.(C.A.: Cushion area)

PACKING DRAWING

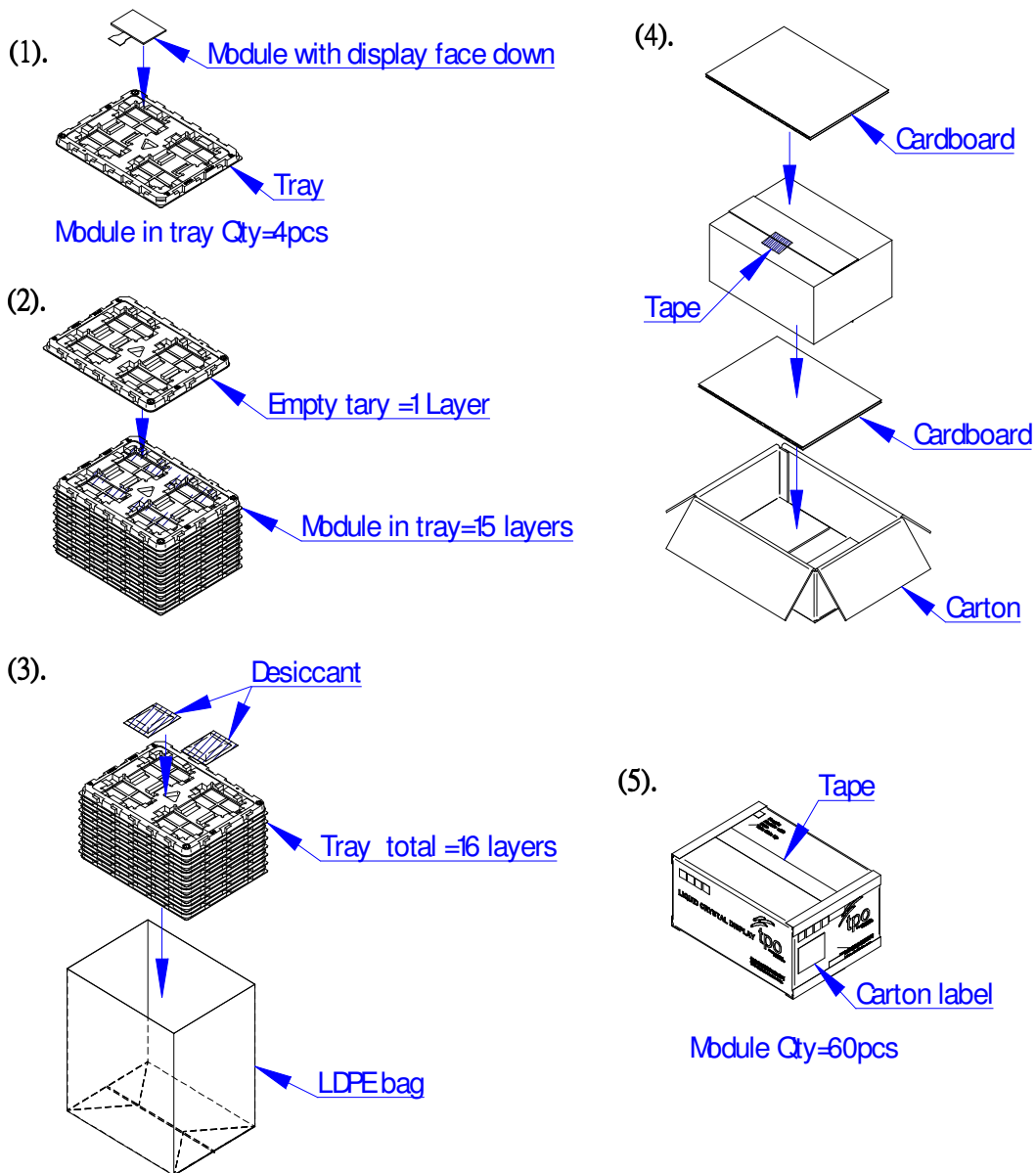

4.3" module (TD043MTEA1) delivery packing method

- (1). Module packed into tray cavity (with Module display face down).
- (2). Tray stacking with 15 layers and with 1 empty tray above the stacking tray unit.
2pcs desiccant put above the empty tray
- (3). Stacking tray unit put into the LDPE bag and fix by adhesive tape.
- (4). Put 1pc cardboard inside the carton bottom, and then pack the package unit into the carton. Put 1pc cardboard above the package unit.
- (5). Carton taping with adhesive tape.