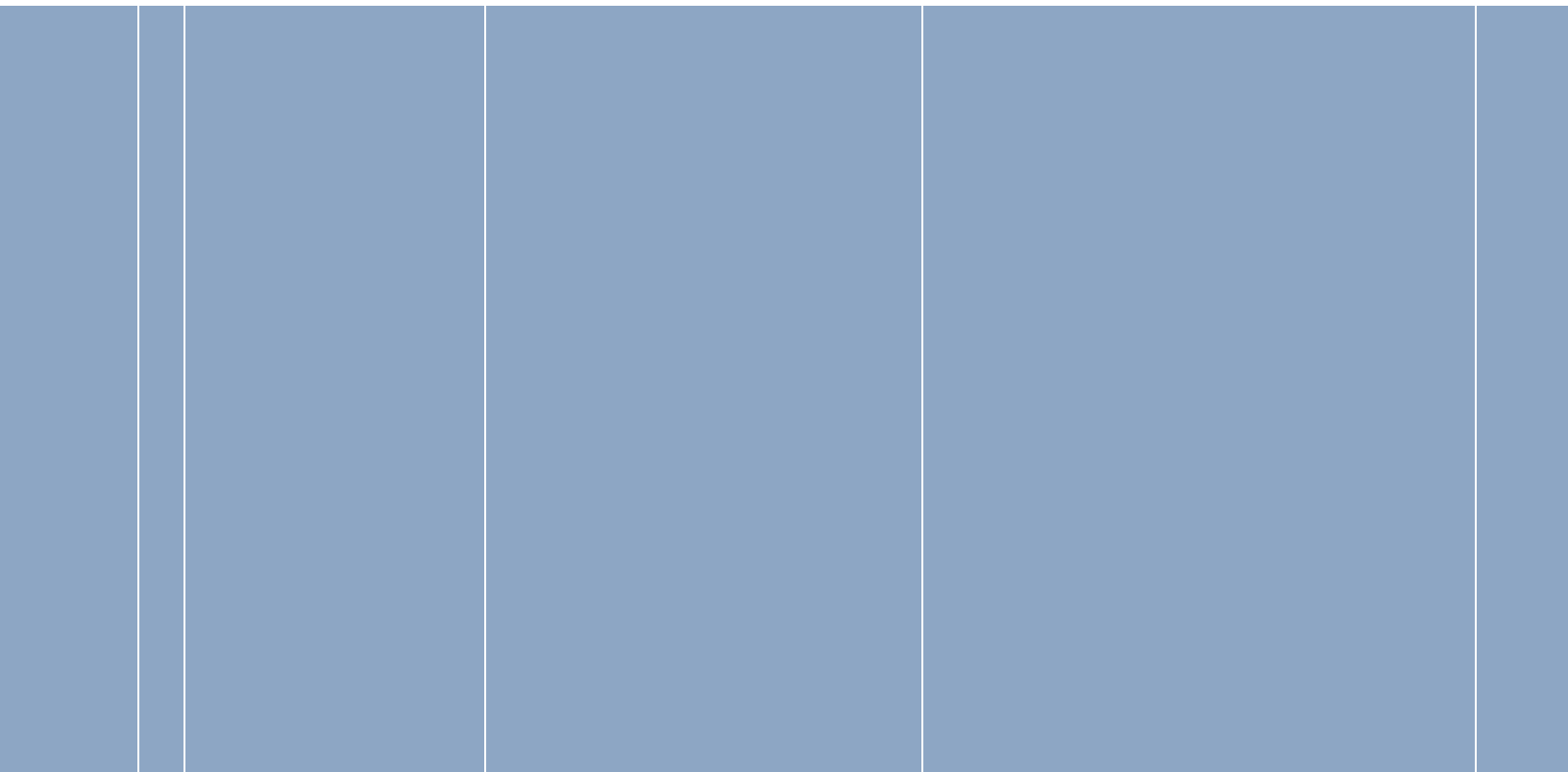


# TD100 Series

## Pressure Transducer Displays



### User Guide

Celerity, Inc.  
915 Enterprise Boulevard  
Allen, TX 75013 USA  
T +1 972 359 4000  
F +1 972 359 4100

153-30268-000 REV. 002 05/08



<b>_1.0 PRODUCT DESCRIPTION AND SPECIFICATIONS</b>	<b>1</b>
_1.1 INTRODUCTION	1
_1.2 INTENDED USE	1
_1.3 PRODUCT DESCRIPTION CODE (PDC)	1
_1.4 PRODUCT LABELING	2
_1.5 TD100 DIMENSIONS	2
_1.6 TD100 SPECIFICATIONS	3
<b>_2.0 UNPACKING AND INSTALLATION INSTRUCTIONS</b>	<b>4</b>
_2.1 UNPACKING AND INSTALLATION	4
_2.2 UNPACKING	4
_2.3 ELECTRICAL INSTALLATION	4
_2.4 CONNECTING THE TD100 TO OPERATE A RELAY	6
_2.5 POSITIONING THE TD100	6
<b>_3.0 OPERATION</b>	<b>7</b>
_3.1 TD100 OPERATION	7
_3.2 USER MENU FLOW CHART	8
_3.3 OPERATING THE USER MENU	9
<b>_4.0 APPENDIX</b>	<b>10</b>
TD100 CALIBRATION	
<b>_5.0 WARRANTY</b>	<b>12</b>

### 1.1 INTRODUCTION

Local display of process pressure improves safety and quality control of gas delivery systems. The Celerity TD100 Series Pressure Transducer Display (shown in Figure 1) allows a 4-20 mA pressure transducer to digitally display pressure and send the signal to a final destination. The pressure transducer, such as a Celerity SS2 Pressure Transducer, connects to either the back or bottom of the TD100 with a 4-pin Bendix connector. The TD100 connects to the loop through a 6-wire pigtail cable or to a 4-pin male Bendix connector. The TD100 offers a real time reading. It is loop powered, single channeled, and can swivel around the transducer so the view angle can be adjusted. The display has red LED lighting for easy reading and has two, adjustable alarm setpoints.



Figure 1: TD100 Pressure Transducer Display

### 1.2 INTENDED USE

TD100 Pressure Transducer Displays are used in semiconductor gas delivery systems such as gas cabinets, gas panels, gas distribution systems, and bulk gas.

### 1.3 PRODUCT DESCRIPTION CODE (PDC)

The following Product Description Code (PDC) identifies the TD100 Pressure Transducer Display. This code is used to order the product. Call your Celerity Customer Service Center if you need assistance.

<b>TD100</b>	<b>-X</b>	<b>-X</b>	<b>-X</b>	
	1 2	<b>Transducer Connection Placement:</b> Back Mount Bottom Mount		
		1 2	<b>External Connector Type:</b> Pigtail 6 wire (2 switched setpoints, programmable either ascending or descending only) Bendix out (no switched setpoints)	
			S A thru Z	<b>Customer Specials:</b> Standard offering Customer specials

Example Order:

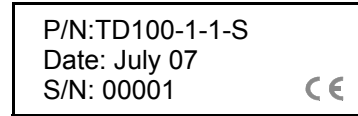
<b>TD100</b>	<b>-1</b>	<b>-1</b>	<b>-S</b>
--------------	-----------	-----------	-----------

**NOTICE!**

From this point forward, the TD100 Pressure Transducer Display will be referred to in general terms as the "TD100".

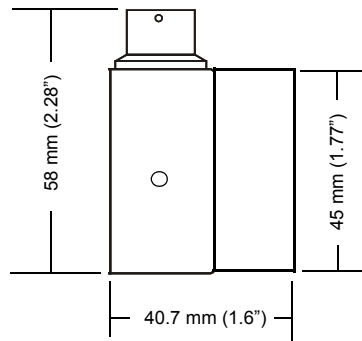
**1.4 PRODUCT LABELING**

The product label shown in Figure 2 identifies the TD100 by part number, serial number, and manufacturing date. This label is located on the back of the display.

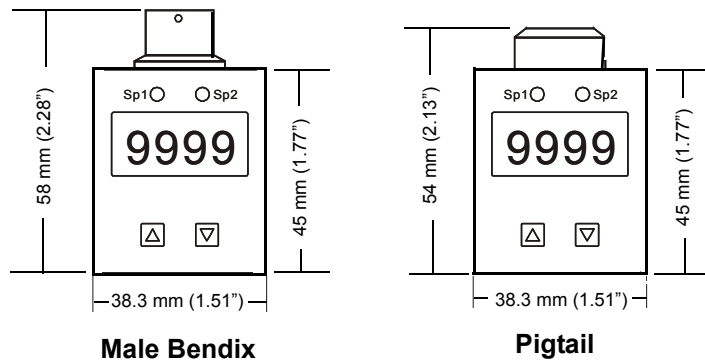


**Figure 2: Product Label**

**1.5 TD100 DIMENSIONS**



**Side View**



**Male Bendix**

**Pigtail**

**Figure 3: TD100 Dimensions**

## 1.6 TD100 SPECIFICATIONS

Category	Specification
<b>Features</b> 4-20 mA Measuring units available Setpoint indication and contact switching Swivel around transducer for better viewing angle Two user programmable/adjustable alarm setpoints	Yes Programmable zero and full scale Available Yes Yes
<b>Display</b> Accuracy Conversion rate Decimal point Digital damping Digits and type Polarity Range Temperature coefficient Value update	+/-0.1% 10 times/second User adjustable 0.3 to 3 seconds (programmable) 4 digit, red LED with 7 segments Automatic (-) displayed in vacuum -1999 to +9999 +/-0.1% FS/degree F 0.1 to 10 seconds
<b>Material</b> Housing Digit height/width Pigtail length Stability, vibration Stability, shock Shipping weight (approx.)	Aluminum, powder coating 9 mm/5.4 mm 2 M standard, (optional lengths upon request) 15 Grm 10-2000 Hz (Mil-Std-202M20 Cond. B) 50 g, 11 msec (Mil-Std-202, M213 Cond. G) 200 g
<b>Electrical</b> Power requirements Input Input connections Output connections Pressure warnings Setpoint contact rating Resistive load Inductance Switching cycles Protection Short Reverse Access Data storage	Voltage drop <4.5; Minimum lit-up current 3 mA 4-20 mA (2 wire, loop powered) Back mount, 4-pin female Bendix connector, factory wired for 4-20 mA transducer Bottom mount, 4-pin female connector, factory wired for 4-20 mA transducer Top mount, pigtail, 6 wire cable Top mount, male Bendix 4-pin connector 2 switched setpoints for pigtail; 2 visual setpoints for 4-pin Bendix (no switch output) 125 mA maximum and 26 Vdc. electrically isolated 10 K ohm maximum 4.7 mH >80 K Permanent short circuit protection No damage at reverse polarity, but no function Password protection EPROM, 4 K maximum
<b>Environmental</b> Temperature range Operating Storage	-20 to 85°C -40 to 85°C
<b>Compliance</b> CE RoHS	Compliant to EMC directive EN61326 Compliant to EU directive 2002/95/EC

**⚠ CAUTION ⚠**  
*Perform all operations with standard gas handling procedures in accordance with all local codes for safety and ventilation. You MUST wear appropriate clothing and safety apparatus for the gas you are using.*

**⚠ CAUTION ⚠**  
*HANDLE CAREFULLY! This display is a precision instrument. To prevent damage, be careful during the unpacking and installation process.*

### 2.1 UNPACKING AND INSTALLATION

This chapter discusses unpacking and installation requirements. Failure to follow these procedures may adversely affect the product's performance and could void the product warranty. Inspect but DO NOT unwrap any parts until installation. Contact your Celerity representative with any problems.

### 2.2 UNPACKING

The TD100 is double-bagged for cleanroom service and should remain packaged until installation.

Do not remove the TD100 from the protective bag unless you are in a clean environment.

1. Remove the TD100 from the box and carry it into the gray area.
2. Remove the outer protective bag and discard.
3. Carry the TD100 (sealed in the inner bag), into the clean area.

### 2.3 ELECTRICAL INSTALLATION

1. Connect the TD100 to the appropriate transducer as shown in Figure 4.

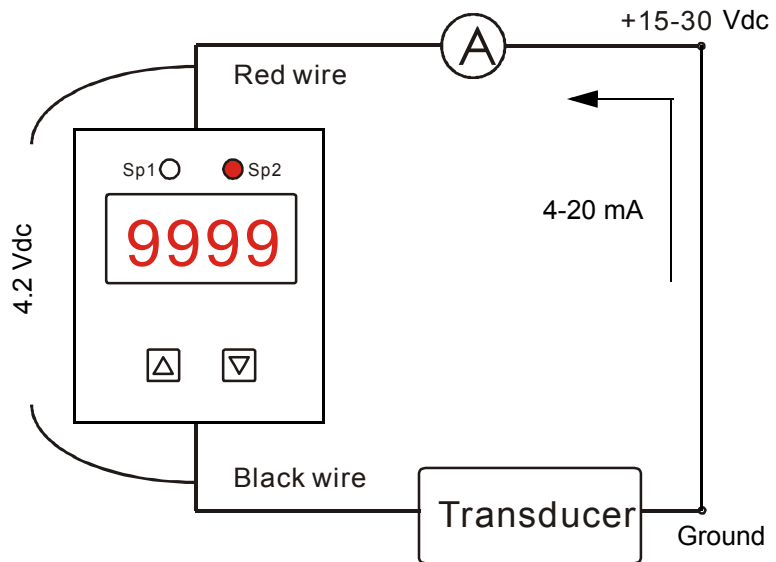
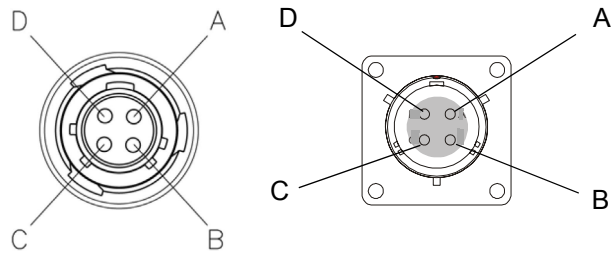


Figure 4: Connecting the TD100 to Transducer

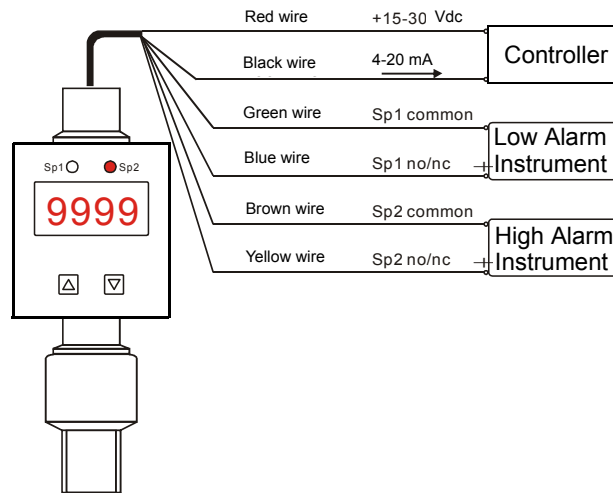
- Turn the MIL-/bendix male and female connector plugs together until the internal part of the plug snaps in. The connector pin configuration is shown in Figure 5.



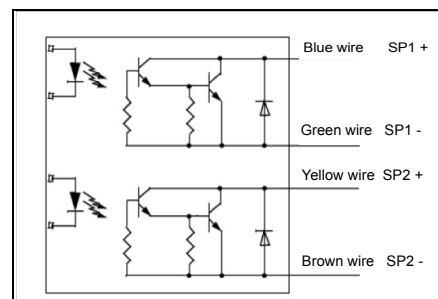
Supply +	A
Supply -	D
Not Connected	B
Ground	C

**Figure 5: Connector Pin Configuration**

- Wire the TD100 as shown in Figure 6. The SP1/SP2 function is illustrated in Figure 7.



**Figure 6: TD100 Wiring Connections**



**Figure 7: Internal Circuit Schematic**

## 2.4 CONNECTING THE TD100 TO OPERATE A RELAY

The TD100 can be connected to operate a relay that uses separate power supplies, or to a relay that uses one power source. Refer to Figure 8 for wiring connections.

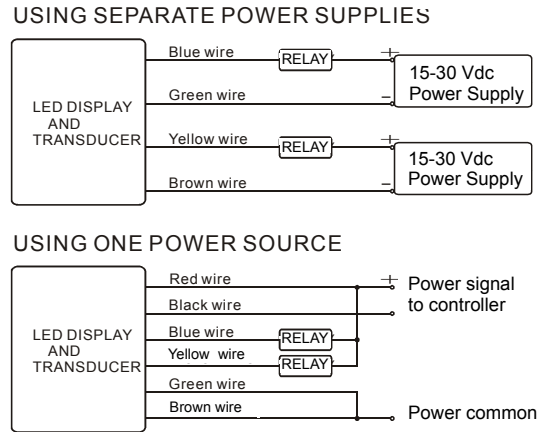


Figure 8: Connecting to a Relay

## 2.5 POSITIONING THE TD100

Turn the TD100 display to the desired position as follows:

1. Loosen the adjustment screw with a 1.5 mm hex wrench. The adjustment screw is located on the side of the device as shown in Figure 9.
2. Manually turn the display to the desired position. Tighten the adjustment screw to lock the position.

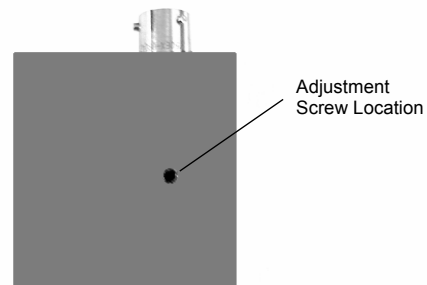
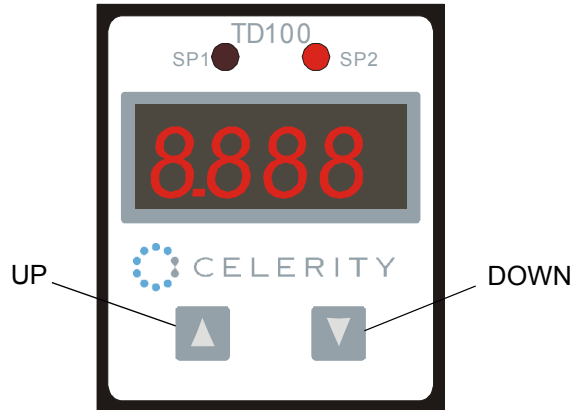




Figure 9: Positioning the TD100



### 3.1 TD100 OPERATION

TD100 operating features are shown in Figure 10. The user menu flow chart is illustrated in Figure 11. User menu operation is described in Figure 12.



Item	Function
UP (Left Button) 	<ol style="list-style-type: none"><li>1. To access the user menu. (Press the button. The menu will appear in 2 seconds.)</li><li>2. To page down.</li><li>3. To change value or function of a selected item.</li><li>4. To set a value within the calibration menu.</li><li>5. To exit the user menu. (Press the button. The menu will exit in 2 seconds.)</li></ol>
DOWN (Right Button) 	<ol style="list-style-type: none"><li>1. To access the user function (sub) menu after the UP button has been pressed.</li><li>2. To move the cursor.</li><li>3. To save data in function (sub) menu and return to previous menu.</li></ol>
UP + DOWN	To access the calibration menu. (Press the UP button, then the DOWN button. Input your password.)
SP1/SP2	Indicates the setpoint has been activated when illuminated.

**Figure 10: Display Panel Operation**

### 3.2 USER MENU FLOW CHART

The TD100 User Menu Flow Chart is described in Figure 11.

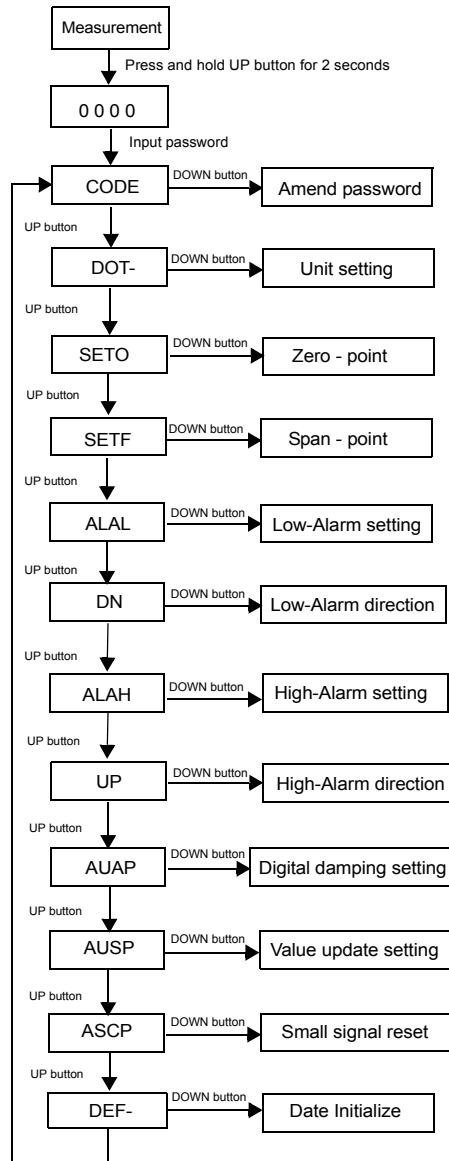
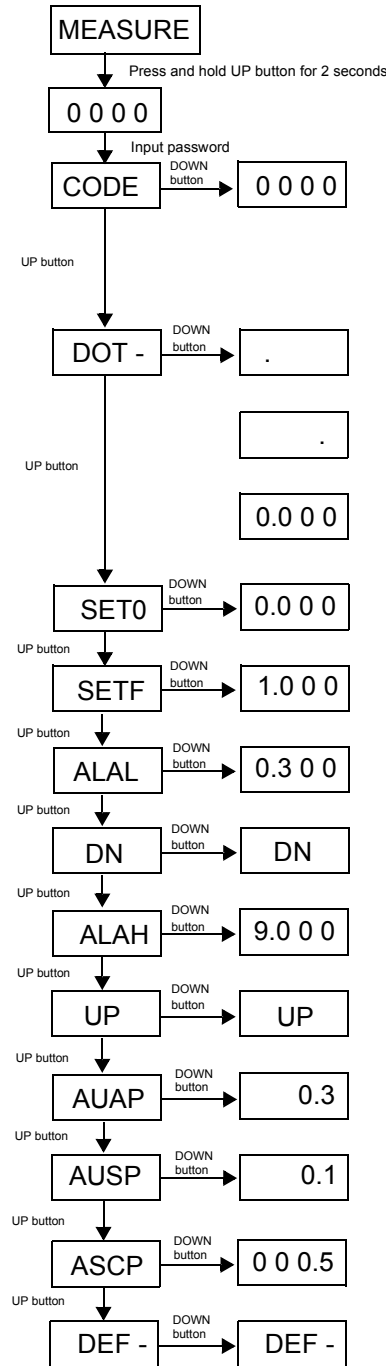


Figure 11: User Menu Flow Chart

### 3.3 OPERATING THE USER MENU

The TD100 must be setup to read the transducer unit setting, zero setpoint, span setpoint, alarms, and other functions. These settings are established from the User Menu as described in Figure 12.



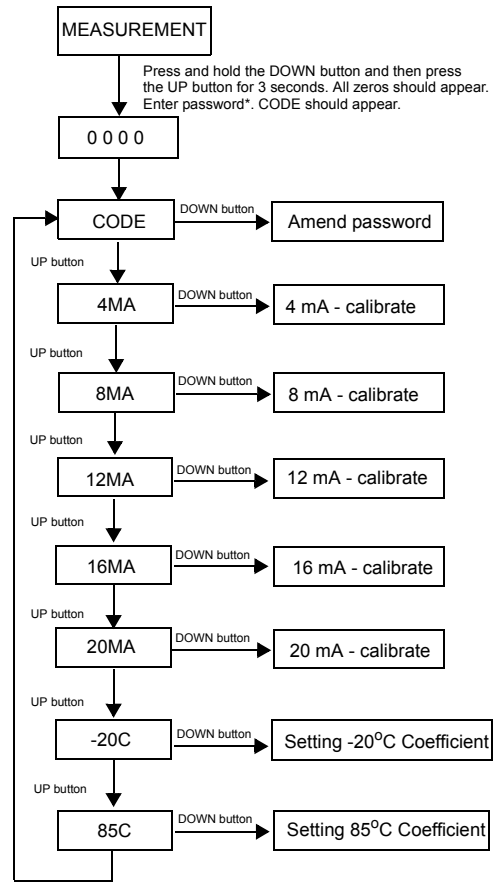
- 1. Measure Mode (MEASURE):**
  - a. Press and hold the UP button for 2 seconds. All zeros should appear. (This is the default password) If it has not changed, press the DOWN button 4 times to enter Configuration menu.
  - b. If the password has changed, press the DOWN button to enter password and to access Configuration Menu.
- 2. Setting Configuration Menu Password (CODE):**
  - a. Enter Configuration Menu with CODE displayed on LED, or current password.
  - b. Press the DOWN button. 0000 should be displayed and the first digit should be flashing.
  - c. Press the UP button to amend value, or press the DOWN button to move the cursor until password setting is complete. *Default password: 0000 Admin password: 0700*
- 3. Unit Setting (DOT):**
  - a. Press the UP button to set unit.
  - b. Press the DOWN button to set unit and to return to previous menu.
- 4. Zero Setting (SET0):**
  - a. Press the UP button to change value.
  - b. Press the DOWN button to move the cursor, to complete the setting, to save the data, and to return to previous menu.
- 5. Span Setting (SETF):**
  - a. Press the UP button to change value.
  - b. Press the DOWN button to move the cursor, to complete the setting, to save the data, and to return to previous menu.
- 6. Low-Alarm Setpoint (ALAL):**
  - a. Press the UP button to change value.
  - b. Press the DOWN button to move the cursor, to complete the setting, to save the data, and to return to previous menu.
- 7. Low-Alarm Direction Setting :**
  - a. Press the UP button to change value.
  - b. Press the DOWN button to move the cursor, to complete the setting, to save the data, and to return to previous menu.
- 8. High-Alarm Setpoint (ALAH):**
  - a. Press the UP button to change value.
  - b. Press the DOWN button to move the cursor, to complete the setting, to save the data, and to return to previous menu.
- 9. High-Alarm Direction Setting :**
  - a. Press the UP button to change value.
  - b. Press the DOWN button to move the cursor, to complete the setting, to save the data, and to return to previous menu.
- 10. Digital Damping Setting (AUAP):**
  - a. Press the UP button to change value. Value range (0.3-3.0 seconds; default is 0.3 seconds)
  - b. Press the DOWN button to move the cursor, to complete the setting, to save the data, and to return to previous menu.
- 11. Value Update Setting (AUSP):**
  - a. Press the UP button to change value. Value range (0.1-10.0 seconds; default is 0.1 seconds)
  - b. Press the DOWN button to move the cursor, to complete the setting, to save the data, and to return to previous menu.
- 12. Low Signal Reset Setting (ASCP):**
  - a. Press the UP button to change value. Value range (0 -100%; default is 0.5%)
  - b. Press the DOWN button to move the cursor, to complete the setting, to save the data, and to return to previous menu.
- 13. Data Initialization (DEF-):**

The LED displays DEF- and flashes. Press and hold the UP button for 3 seconds. The LED displays \_\_\_\_\_. All user data is initialized.

Figure 12: User Menu Operation

**⚠ CAUTION ⚠**  
*The TD100 should only be calibrated by trained, factory personnel. If the TD100 needs to be re-calibrated, it is recommended that you send it to an authorized Celerity Service Center.*

The TD100 Calibration Menu Flow Chart is shown in Figure A1.



\* Call factory for password

**Figure A1: Calibration Menu Flow Chart**

The TD100 is setup to read the transducer's inputs signals and temperature values. These settings are established from the Calibration Menu in Figure A2.

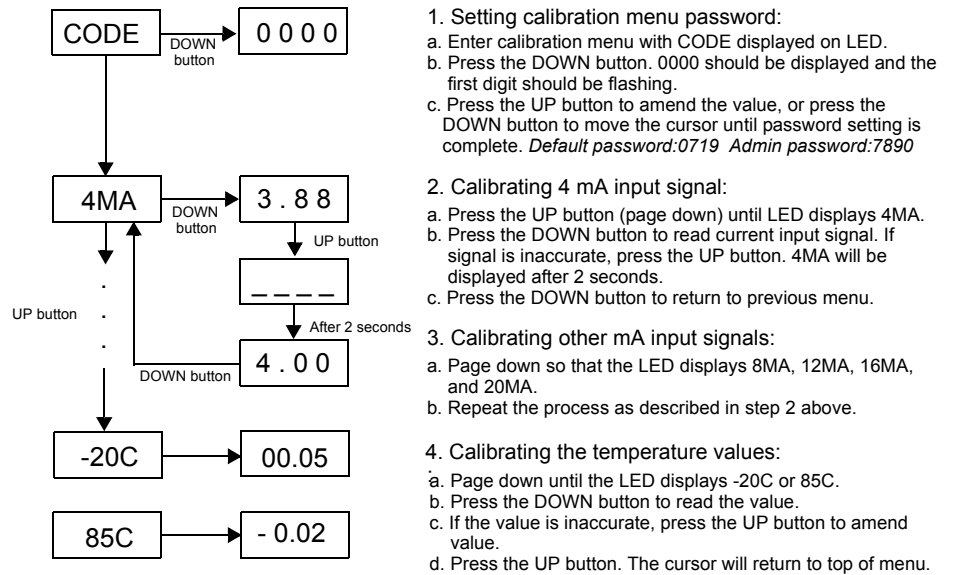


Figure A2: Calibration Menu Operation

Product warranty information can be found on our Celerity website at [www.celerity.net](http://www.celerity.net). This information provides general warranty information, limitations, disclaimers, and applicable warranty periods according to product group.



CELERITY, INC.  
915 Enterprise Boulevard  
Allen, TX 75013 USA  
Telephone 972.359.4000  
Facsimile 972.359.4100  
[www.celerity.net](http://www.celerity.net)



For technical assistance, contact Celerity Technical Support at 972.359.4000.

Celerity is a trademark of Celerity, Inc. All other product or service names mentioned in this document may be trademarks of the companies with which they are associated. System descriptions are typical and subject to change without notice.

©2008 Celerity, Inc.

153-30268-000 Rev 002

05/08