

# TFT LCD Specification

Model Name: TD141TGCD1

<b>Customer Signature</b>
Date

Confirmed by	Checked by	Prepared by
Date	Date	Date

**This technical specification is subjected to change without notice**

## Table of Contents

<b>NO.</b>	<b>Item</b>	<b>Page</b>
	Cover Sheet	1
	Table of Contents	2
	Record of Reversion	3
1	Features	4
2	General Specification	4
3	Input / Output Terminals, Pin Assignment	5
4	Absolute Maximum Ratings	6
5	Electrical Characteristics	6
6	Timing Chart	9
7	Optical Characteristics	13
8	Reliability	17
9	Handling Cautions	18
10	Mechanical Drawing	19
11	Packing Drawing	21
12	Appendix1 EDID	22

## Record of Reversion

Rev	Issued Date	Description
1.00	AUG 24, 2003	Issue Specification.
1.01	DEC 09, 2003	Modify 7.1 Optical Specification Luminance of White (5 Point): From MIN / 130; TYP / 160 cd/m <sup>2</sup> => Change to MIN / 120; TYP / 150 cd/m <sup>2</sup>

## 1. FEATURES

- (1) 14.1" XGA (1024x768 pixels) display size for notebook PC
- (2) LVDS interface system
- (3) Thin and light weight
- (4) High contrast ratio
- (5) Low power consumption.
- (6) Onboard EEDID chip

## 2. GENERAL SPECIFICATION

Item	Description	Unit
Display Size (Diagonal)	14.1 (35.8cm)	inch
Driver Element	LTPS TFT Active Matrix	
Active Area (HxV)	285.696 (H) x 214.272 (V)	mm
Number of Dots (HxV)	1024 x RGB x 768	dot
Pixel Pitch (HxV)	0.279 x 0.279	mm
Color Arrangement	RGB Vertical Stripe	
Color Numbers	262,144 (6 bits)	
Outline Dimension (HxVxT)	299.0x226.5x4.8 (Typ) ; 5.45 (Max ; connector)	mm
Weight	435(Typ) $\pm$ 15	g
Display Mode	Normally White	
Surface Treatment	Anti Glare and Hard-Coating ( 3H )	

### 3. INPUT/OUTPUT TERMINALS

#### 3.1 TFT LCD Panel

Recommend Connector Type: JAE FI-XB30SR-HF11 or Compatible

Matching Connector Type:

FPC : FI-X30M or Compatible

WIRE : FI-X30H or Compatible

Pin No	Symbol	Function	Polarity	Remark
1	VSS	Ground		
2	VDD	Power supply +3.3 v		
3	VDD	Power supply +3.3 v		
4	V <sub>EDID</sub>	DDC 3.3V power		
5	NC	Reserved for supplier test point		
6	Clk <sub>EDID</sub>	DDC Clock		
7	DATA <sub>EDID</sub>	DDC Data		
8	Rin0-	-LVDS differential data input	Negative	R0~R5, G0
9	Rin0+	+LVDS differential data input	Positive	
10	VSS	Ground		
11	Rin1-	-LVDS differential data input	Negative	G1~G5, B0~B1
12	Rin1+	+LVDS differential data input	Positive	
13	VSS	Ground		
14	Rin2-	-LVDS differential data input	Negative	B2~B5 , DE Hsync , Vsync
15	Rin2+	+LVDS differential data input	Positive	
16	VSS	Ground		
17	Clk_IN-	-LVDS differential clock input	Negative	
18	Clk_IN+	+LVDS differential clock input	Positive	
19	VSS	Ground		
20	NC	NC		
21	NC	NC		
22	VSS	Ground		
23	NC	NC		
24	NC	NC		
25	VSS	Ground		
26	NC	NC		
27	NC	NC		
28	VSS	Ground		
29	NC	NC		
30	NC	NC		

### 3.2 Light Source

Light Source Type: CCFL Back Light

Recommend Connector Type : JST BHSR – 02VS - 1

Pin NO.	Symbol	Color	Function
1	V <sub>H</sub>	Pink	High Voltage
2	V <sub>L</sub>	White	Low Voltage

## 4. ABSOLUTE MAXIMUM RATINGS

GND =0V

Item	Symbol	MIN	MAX	Unit	Remark
Power Supply Voltage	V <sub>CC</sub>	V <sub>SS</sub> -0.3	4.0	V	
Logic Input Voltage	V <sub>IN</sub>	V <sub>SS</sub> -0.3	(V <sub>SS</sub> +0.3)	V	
Lamp Current	I <sub>L</sub>	2.0	7.0	mA rms	
Lamp Frequency	F <sub>L</sub>	50	80	KHz	
Operating Temperature	T <sub>OPR</sub>	0	+50	°C	
Storage Temperature	T <sub>STG</sub>	-25	+60	°C	
Storage Humidity	H <sub>STG</sub>	10	90	%RH	Note 4-1

Note 4-1: Maximum wet – bulb temperature at 39°C or less. ( Ta > 40°C ) No condensation

## 5. ELECTRICAL CHARACTERISTICS

### 5.1 TFT LCD Module

Ta=25°C

Item	Symbol	MIN	TYP	MAX	Unit	Remark	
Voltage of power supply	V <sub>DD</sub>	3.0	3.3	3.6	V		
Differential Input Threshold Voltage	High	V <sub>H<sub>I</sub>H</sub>	--	--	100	mV	V <sub>CM</sub> = +1.2V
	Low	V <sub>H<sub>I</sub>L</sub>	-100	--	--	mV	
Rush Current	I <sub>RUSH</sub>	--	--	1.5	A		
Vsync Frequency	f <sub>V</sub>		60		Hz		
Hsync Frequency	f <sub>H</sub>		48.2		KHz		
Main Frequency	f <sub>DCLK</sub>	63.4	65	66.6	MHz		
Current of Power Supply	White	--	330	--	mA		
	Mosaic	--	350	--	mA		
	Max Pattern (One dot inversion)	--	380	450	mA		

Driving TFT LCD Module Block Diagram

1-CH LVDS INTERFACE

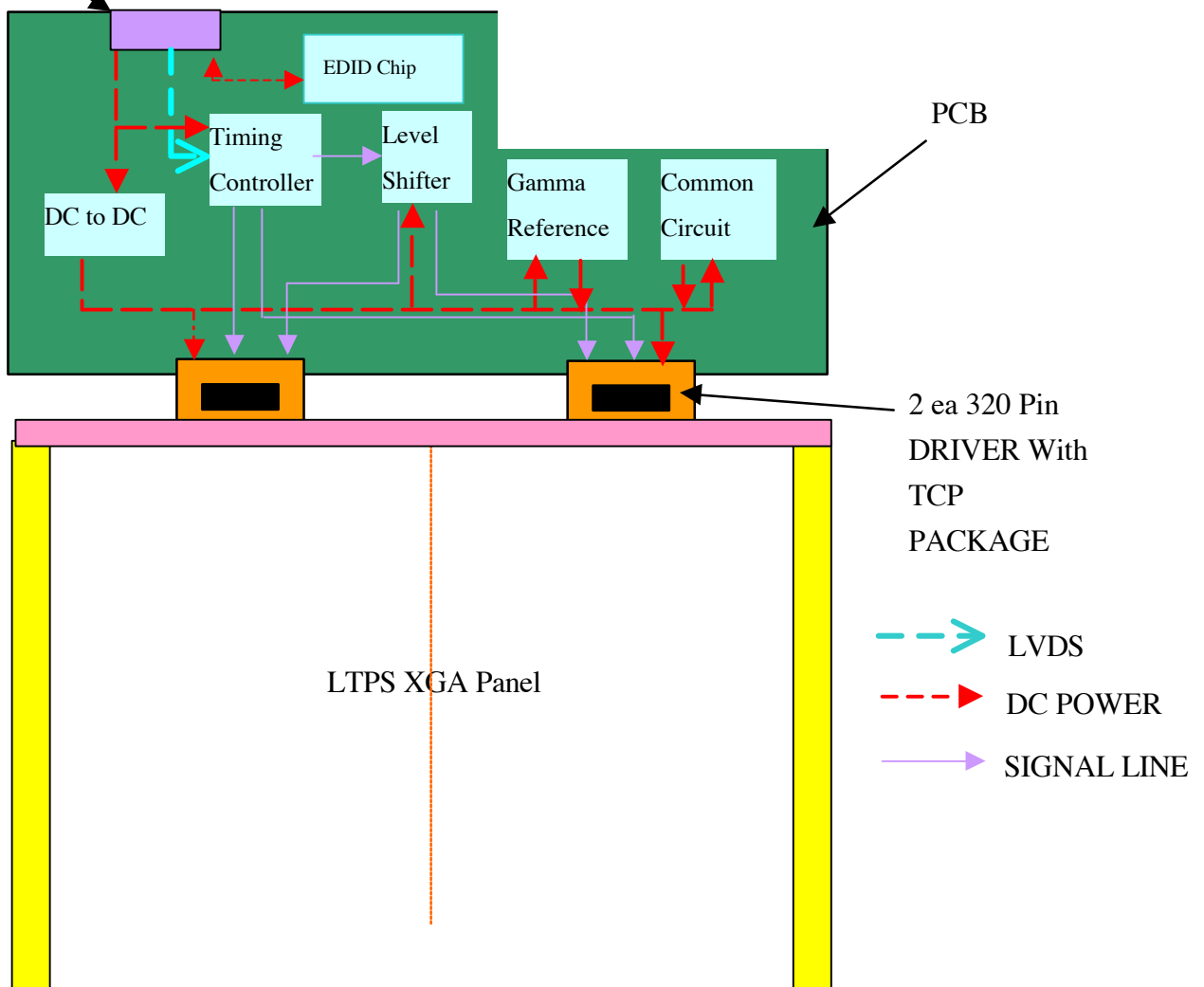

5.2 Driving Backlight

The backlight system is an edge – lighting type with a single CCFL (Cold Cathode Fluorescent Tube)  
 The characteristics of a single lamp are shown in the following tables.

Ta=25°C

Item	Symbol	MIN	TYP	MAX	Unit	Remark
Lamp Current	$I_L$	3.0	6.0	6.5	mArms	Note 5-1
Lamp Voltage	$V_L$	--	660	--	Vrms	$I_L=6mA$
Power Consumption	$P_L$	--	3.96	--	W	Note 5-2
Frequency	$F_L$	50	60	80	kHz	Note 5-3
Operating Life time	Hr	10,000	--	--	Hour	Note 5-4
Lamp starting voltage	$V_s$	--	--	1160 (25°C)	Vrms	Note 5-5
				1450 (0°C)		

The information contained herein is the exclusive property of toppoly Optoelectronics corporation, and shall not be distributed, reproduced, or disclosed in whole or in part without prior written permission of toppoly Optoelectronics corporation.

Note 5-1: Lamp current is measured with a high frequency current meter as show below.

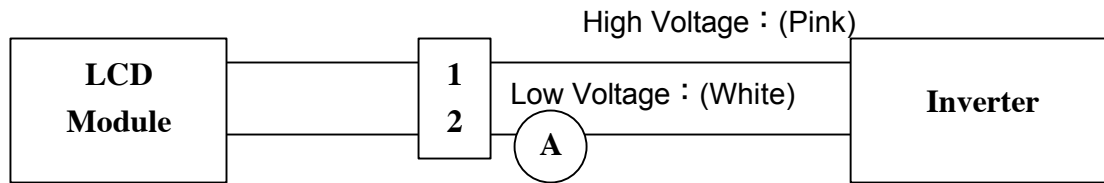

Switching Frequency : (50~80)KHz

Note 5-2:  $W = I_L \times V_L$

Note 5-3: Lamp frequency may produce interference with horizontal synchronous frequency and this may cause line flow on the display. Therefore lamp frequency shall be detached from the horizontal synchronous frequency and its harmonics as far as possible in order to avoid interference.

Note 5-4: Brightness is decreased to the 50% of the initial value.

Note 5-5: Above this value should be applied to the lamp for more than 1 second to startup, otherwise the lamp may not be turned on.



## 6. TIMING CHART

### 6.1 LVDS Channel Interface Data Mapping Diagram

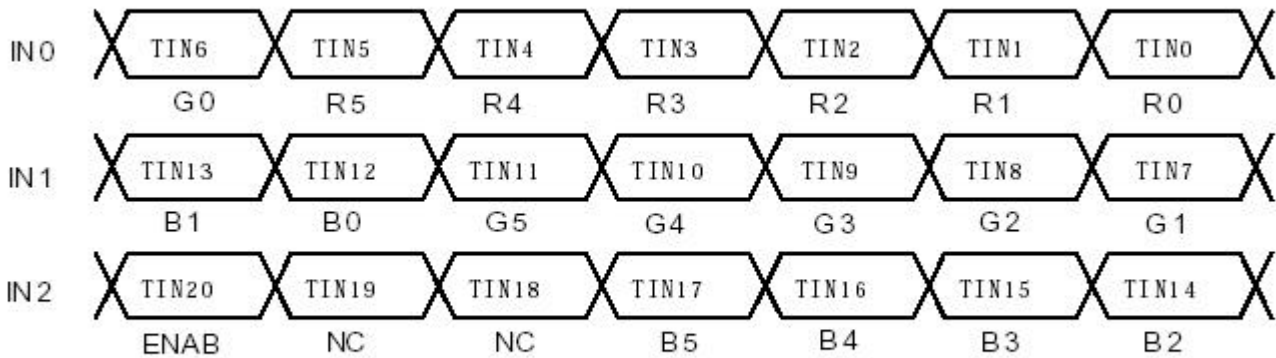

### 6.2 Pixel Format in Display

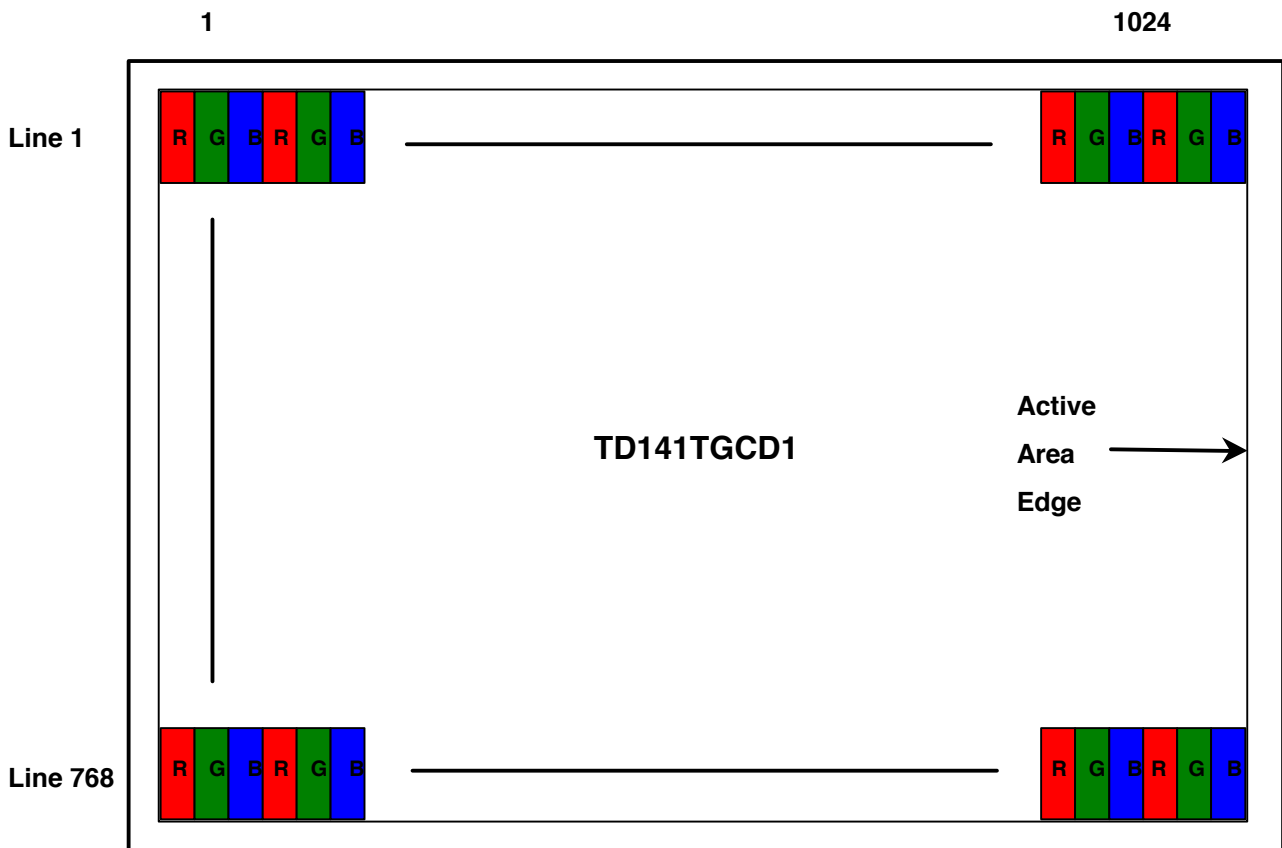

6.3 Input Signals, Basic Display Color and Gray Scale of Each Color

Input Signals, Basic Display Colors and Gray Scale of Each Color

COLOR	DISPLAY	DATA SIGNAL																GRAY SCALE LEVEL		
		RED					GREEN					BLUE								
		R0	R1	R2	R3	R4	R5	G0	G1	G2	G3	G4	G5	B0	B1	B2	B3		B4	B5
COLOR	BLACK	0	0	0	0	0	0	0	0	0	0	0	0	0	0	0	0	0	0	-
	BLUE	0	0	0	0	0	0	0	0	0	0	0	0	1	1	1	1	1	1	-
	GREEN	0	0	0	0	0	0	1	1	1	1	1	1	0	0	0	0	0	0	-
	CYAN	0	0	0	0	0	0	1	1	1	1	1	1	1	1	1	1	1	1	-
	RED	1	1	1	1	1	1	0	0	0	0	0	0	0	0	0	0	0	0	-
	MAGENTA	1	1	1	1	1	1	0	0	0	0	0	0	1	1	1	1	1	1	-
	YELLOW	1	1	1	1	1	1	1	1	1	1	1	1	0	0	0	0	0	0	-
	WHITE	1	1	1	1	1	1	1	1	1	1	1	1	1	1	1	1	1	1	-
GRAY SCALE OF RED	BLACK	0	0	0	0	0	0	0	0	0	0	0	0	0	0	0	0	0	0	R0
	DARK ↑	1	0	0	0	0	0	0	0	0	0	0	0	0	0	0	0	0	0	R1
		0	1	0	0	0	0	0	0	0	0	0	0	0	0	0	0	0	0	R2
		: : : : : : : : : : : : : : : : : :	R3~R60																	
	LIGHT ↓	1	0	1	1	1	1	0	0	0	0	0	0	0	0	0	0	0	0	R61
		0	1	1	1	1	1	0	0	0	0	0	0	0	0	0	0	0	0	R62
		RED	1	1	1	1	1	1	0	0	0	0	0	0	0	0	0	0	0	0
	GRAY SCALE OF GREEN	BLACK	0	0	0	0	0	0	0	0	0	0	0	0	0	0	0	0	0	0
DARK ↑		0	0	0	0	0	0	1	0	0	0	0	0	0	0	0	0	0	0	G1
		0	0	0	0	0	0	0	1	0	0	0	0	0	0	0	0	0	0	G2
		: : : : : : : : : : : : : : : : : :	G3~G60																	
LIGHT ↓		0	0	0	0	0	0	1	0	1	1	1	1	0	0	0	0	0	0	G61
		0	0	0	0	0	0	0	1	1	1	1	1	0	0	0	0	0	0	G62
		GREEN	0	0	0	0	0	0	1	1	1	1	1	1	0	0	0	0	0	0
GRAY SCALE OF BLUE		BLACK	0	0	0	0	0	0	0	0	0	0	0	0	0	0	0	0	0	0
	DARK ↑	0	0	0	0	0	0	0	0	0	0	0	0	1	0	0	0	0	0	B1
		0	0	0	0	0	0	0	0	0	0	0	0	0	1	0	0	0	0	B2
		: : : : : : : : : : : : : : : : : :	B3~B60																	
	LIGHT ↓	0	0	0	0	0	0	0	0	0	0	0	0	1	0	1	1	1	1	B61
		0	0	0	0	0	0	0	0	0	0	0	0	0	1	1	1	1	1	B62
		BLUE	0	0	0	0	0	0	0	0	0	0	0	0	1	1	1	1	1	1

6.4 Interface Timing

a. Timing Parameters

Signal	Item	Symbol	MIN	TYP	MAX	Unit	Note
Frame Frequency	Cycle	$T_V$	-	806	-	Lines	
Vertical Active Display Term	Display Period	$T_{VD}$	-	768	-	Lines	
One Line Scanning Time	Cycle	$T_H$	-	1344	-	Clocks	
Horizontal Active Display Term	Display Period	$T_{HD}$	-	1024	-	Clocks	

b. Timing Diagrams Of Interface Signal

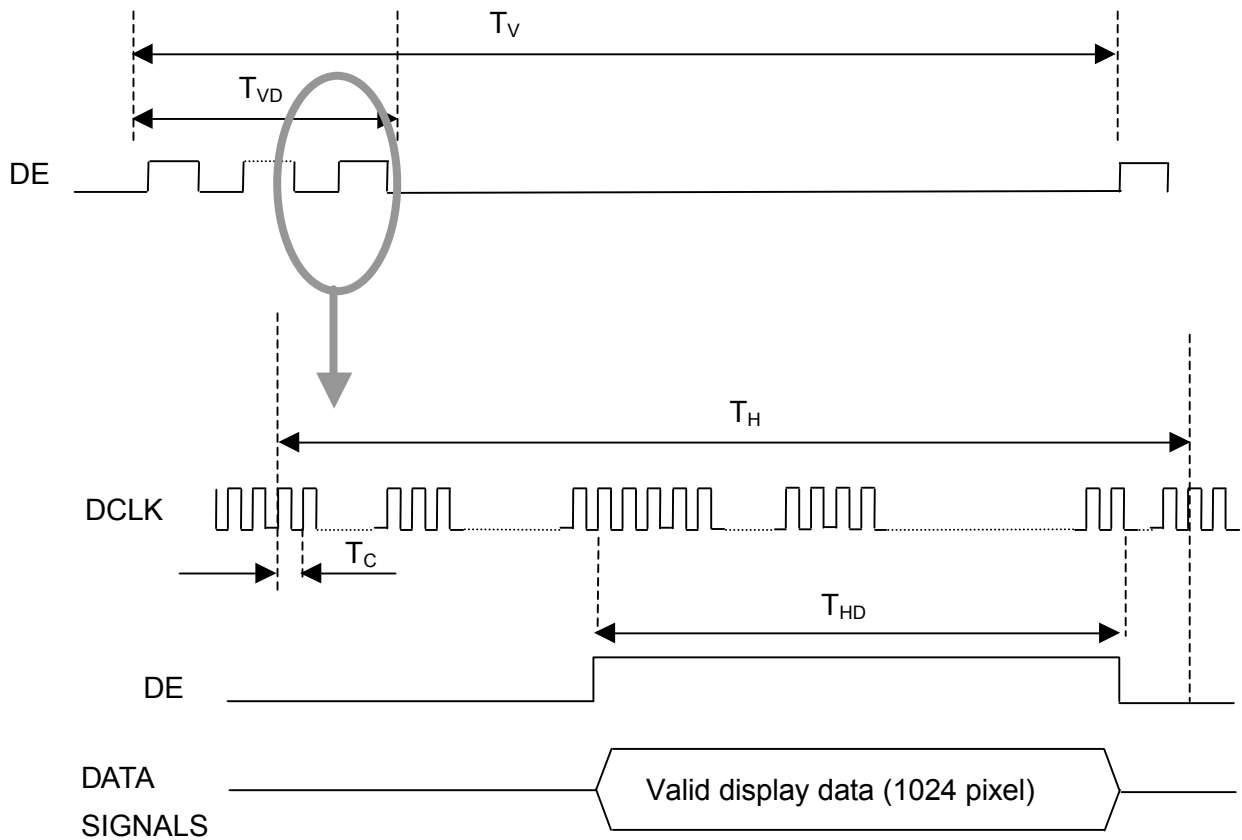

## 6.5 Power ON/OFF Sequence

To prevent a latch-up or DC operation of the LCD module, the power on/off sequence should be as the diagram below.

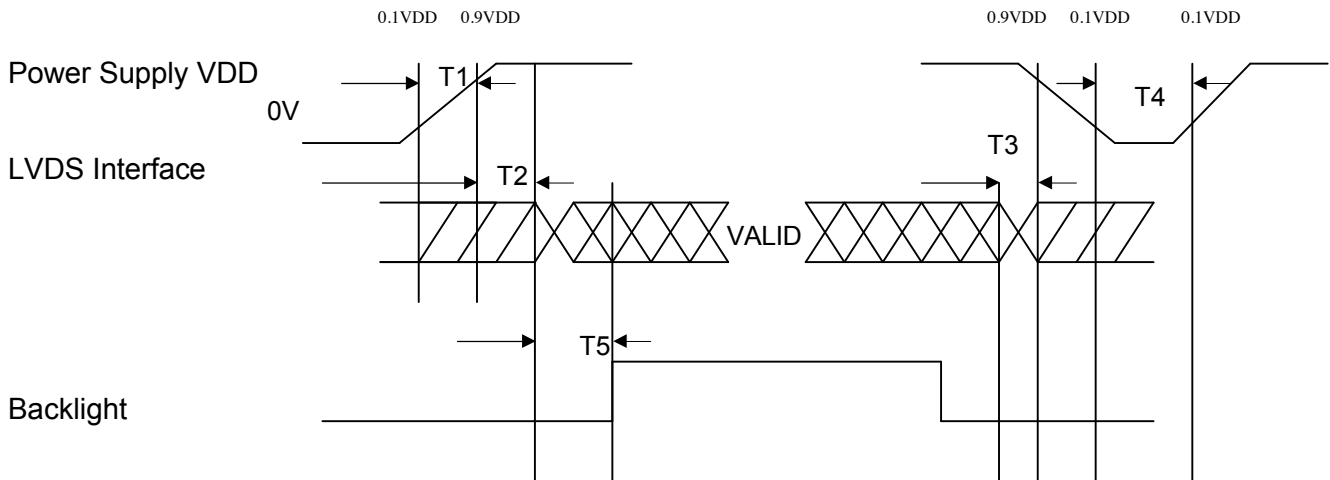

$$T1 \leq 10\text{ms} \quad 0 \leq T2 \leq 50\text{ms} \quad 0 \leq T3 \leq 50\text{ms} \quad 400\text{ms} \leq T4 \quad 200\text{ms} \leq T5$$

T1: VDD rising time from 0.1VDD to 0.9VDD.

T2: The time from 0.9VDD to valid data at power ON.

T3: The time from 0.9VDD to valid data at power OFF.

T4: VDD off time for window restarts.

T5: The time from valid data to B/L enable at POWER ON.

**7. OPTICAL CHARACTERISTICS**
**7.1 Optical Specification**

Ta=25°C

Item		Symbol	Condition	MIN	TYP	MAX	Unit	Remarks	
Viewing Angle	Hor.	$\theta_{11}$	CR=10 (At center point)	-	40	-	degree	Note 7-1	
		$\theta_{12}$		-	40	-			
	Ver.	$\theta_{21}$		-	15	-			
		$\theta_{22}$		-	35	-			
Contrast ratio (5 Point)		CR		200	300	-		Note 7-2	
Response time	Rising	Tr	$\theta = 0^\circ$ $\phi = 0^\circ$ Normal Viewing Angle	-	8	10	ms	Note 7-4	
	Falling	Tf		-	15	20			
Luminance of White (5 Point)		$Y_L$			120	150	-	cd/m <sup>2</sup>	Note 7-5
Color Chromaticity (CIE1931)	Red	$R_x$			0.55	0.58	0.61		Note 7-6
		$R_y$			0.33	0.36	0.39		
	Green	$G_x$			0.26	0.29	0.32		
		$G_y$			0.53	0.56	0.59		
	Blue	$B_x$			0.12	0.15	0.18		
		$B_y$			0.08	0.11	0.14		
	White	$W_x$			0.28	0.31	0.34		
		$W_y$		0.30	0.33	0.36			
13 Points White Variation		$\delta_L$		0.65	-	-		Note 7-3	

**7.2 Basic measure condition**

- (1) Ambient temperature: Ta=25°C
- (2) Vcc = 3.3V°
- (3) Fv = 60Hz
- (4) f<sub>DCLK</sub> = 65MHz
- (5) I<sub>L</sub> = 6mA
- (6) Inverter model: HIU-766 (62K)  
Environmental illumination: = 10 Lux
- (7) Testing facility

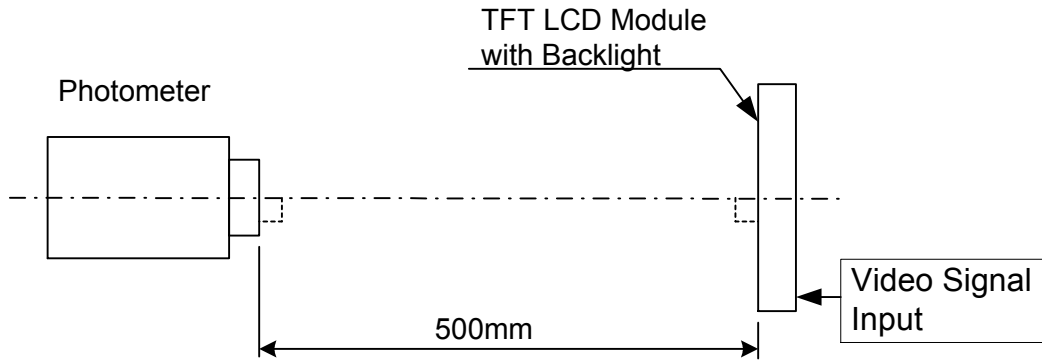

Note 7-1: Viewing angle diagrams:

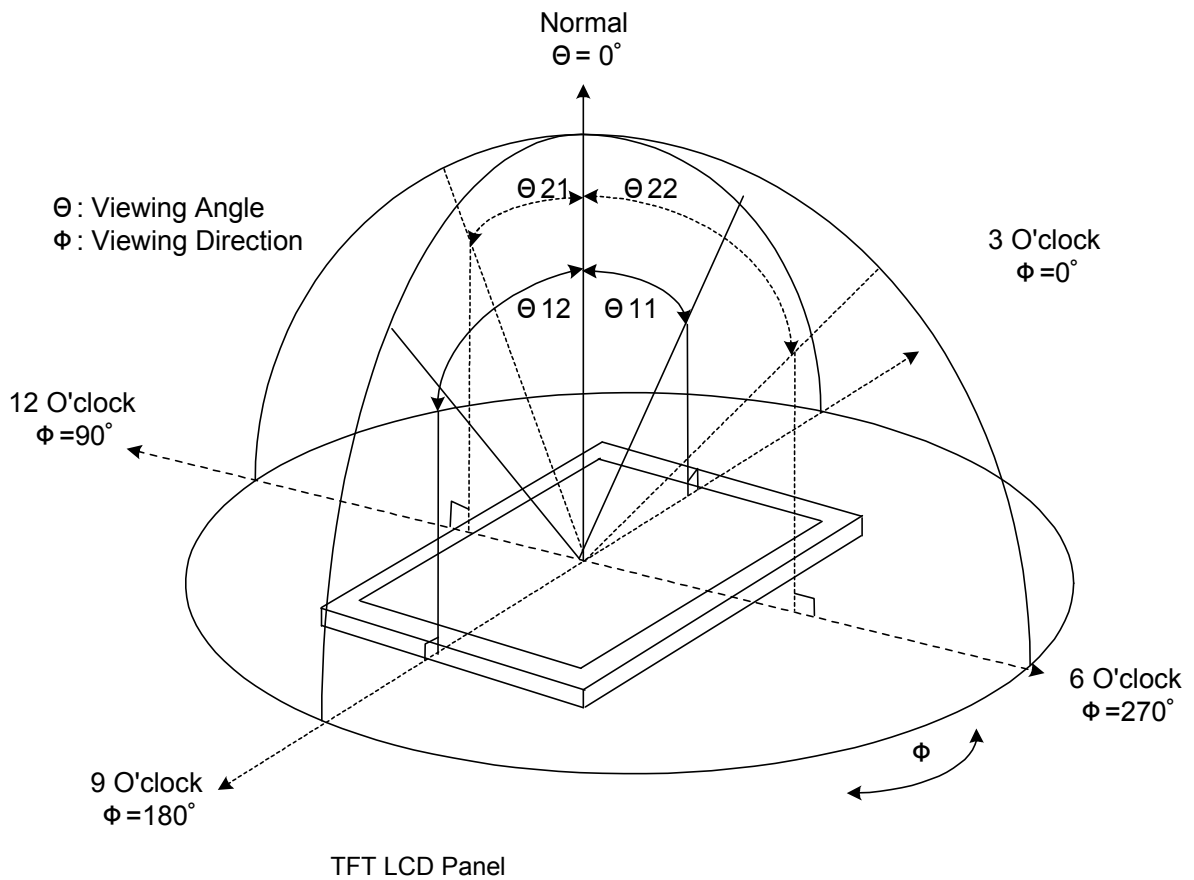

Note 7-2: Definition of Contrast ratio : Ratio of gray max (Gmax), gray min (Gmiin) at 5 point

$$CR = \frac{CR(A) + CR(B) + CR(C) + CR(D) + CR(E)}{5}$$

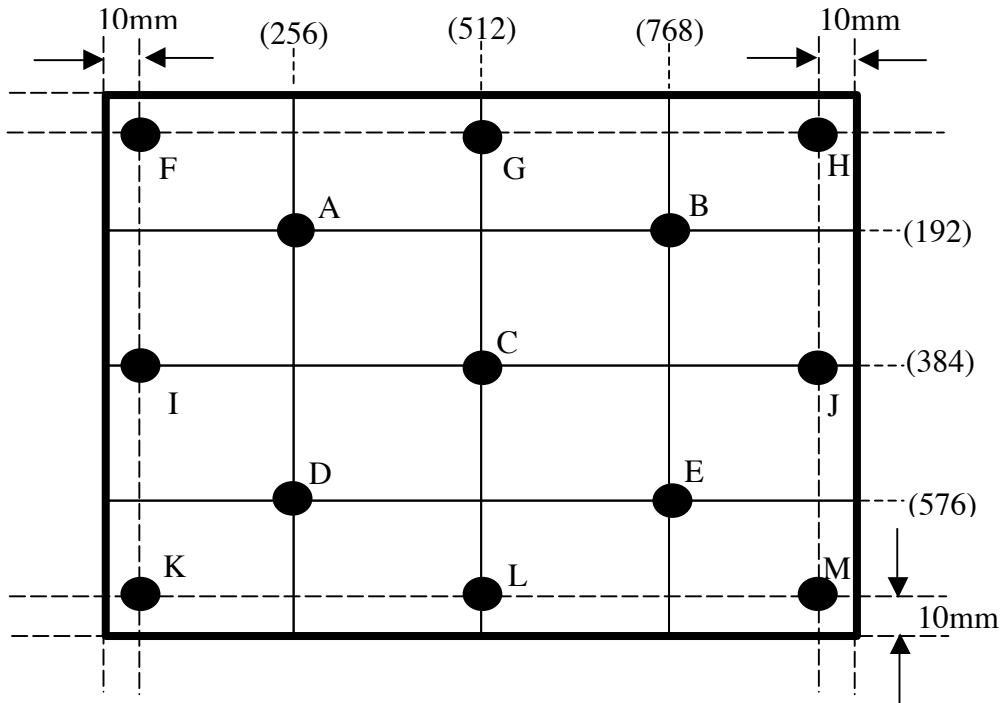

Note 7-3: Definition of uniformity; 13 point, Test point as Note 7-2

$$\delta_L = \frac{\text{Minimum Luminance of 13 point}}{\text{Maximum Luminance of 13 point}}$$

Note 7-4: Definition of response time:

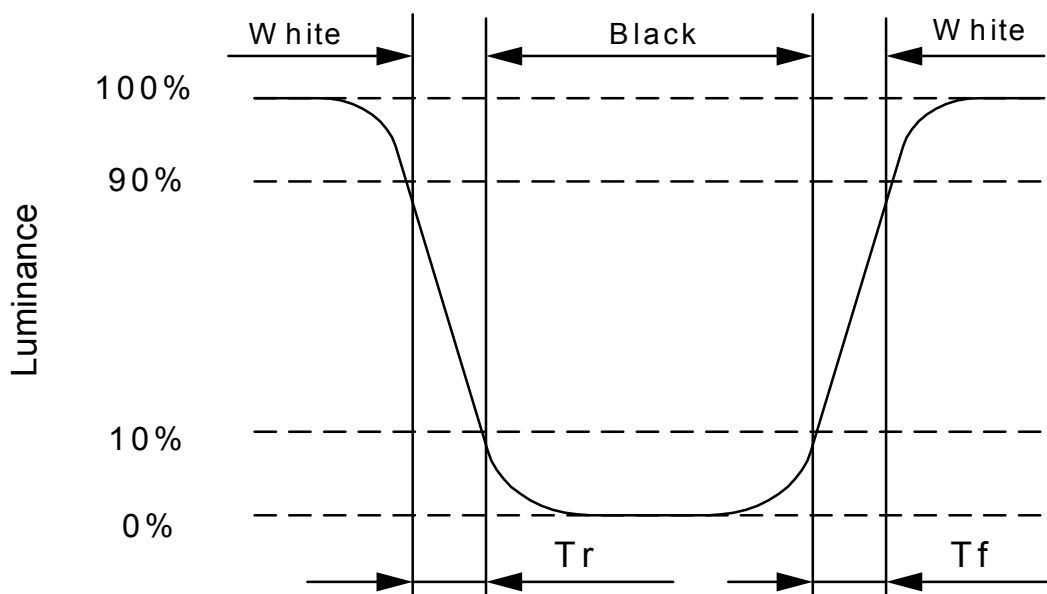

Note 7-5: Definition of Average Luminance of White : measure the luminance of white at 5 points.

Luminance of White (5 Point) ( $Y_{L, AVE}$ )

$$Y_{L, AVE} = \frac{Y_A + Y_B + Y_C + Y_D + Y_E}{5}$$

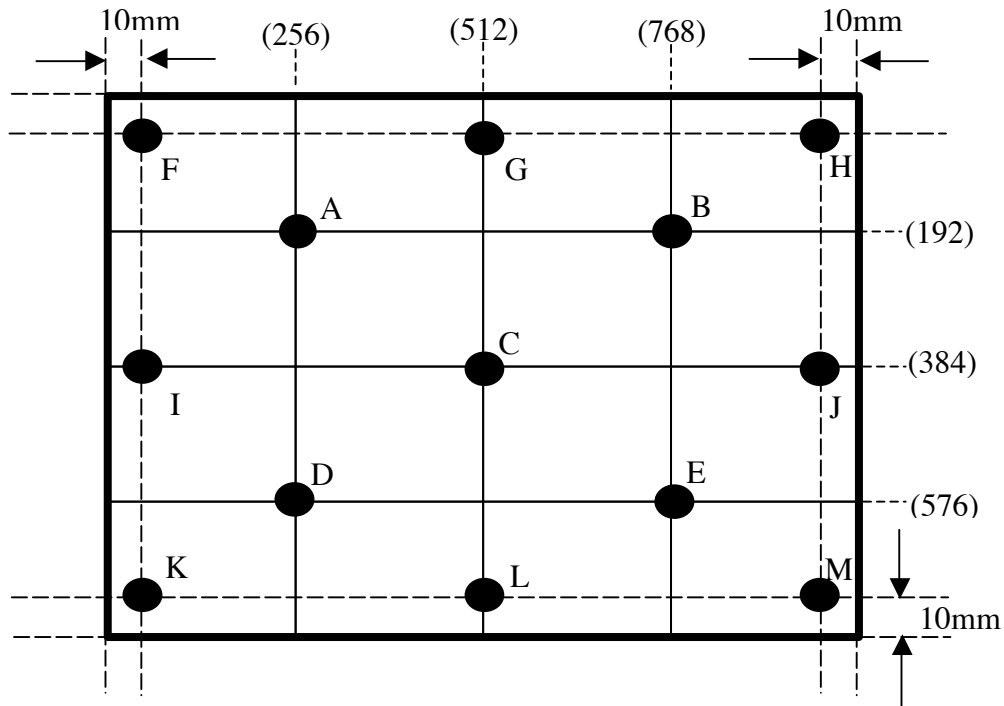

Note 7-6: To be measured in dark room environment and after lighting the backlight for 30 minutes.



**8. RELIABILITY**

No	Test Item	Condition
1	High Temperature Operation	Ta=+50°C, 240hrs
2	High Temperature & High Humidity Operation No Condensation	Ta=+40°C, 90% RH, 240hrs
3	Low Temperature Operation	Ta=0°C, 240hrs
4	High Temperature Storage	Ta=+60°C, 240hrs
5	Low Temperature Storage	Ta=-25°C, 240hrs
6	Surface Discharge (non-operation)	C=150pF, R=330 Ω; Discharge: Air: ±5kV; Contact: ±5kV 5 Times / Point; 5 Points / Panel
7	Vibration (non-operation)	Frequency: 10~300~10Hz 1.5 x 9.8m/s <sup>2</sup> constant Amplitude: 1.5mm; Sweep Time: 15min Test Time: 0.5 hr for each direction of X, Y, Z
8	Shock (non-operation)	Half-sine wave 220 G, 2ms, ±X, ±Y, ±Z (Once for each direction)

Ta: Ambient Temperature

Note 8.1: Evaluation should be tested after one hour of room temperature storage.

## 9. HANDLING CAUTIONS

- 9.1 Module assembly working environment should be in the clean room.
- 9.2 The polarizer is easily damaged, handle it carefully and do not press or scratch the surface by sharp material.
- 9.3 Panel has polarizer protective film on the surface, please remove the protection film of the polarizer slowly to prevent electrostatic discharge.
- 9.4 It is not permitted to apply pressure or impulse to the module, as this may cause LCD panel or backlight damage.
- 9.5 Turn off the power supply before connecting and disconnecting signal input cables.
- 9.6 The lamp wire is very weak, do not handle the panel only by the lamp wire.
- 9.7 As the packing bag is opened, watch out for the environment of the panel storage. High temperature and high humidity environments are prohibited.
- 9.8 Please store the LCD module within the specified conditions. High temperature or high humidity environments may reduce module performance.
- 9.9 Do not disassemble the module.
- 9.10 Do not touch the backlight connector. The backlight start voltage is about 1000V, which may cause electrical shock.
- 9.11 Do not adjust the variable resistor located on the back side of the module.
- 9.12 I/F connector pins shall not be touched directly with bare hands.
- 9.13 When the TFT LCD module is broken or liquid crystal leaks from the panel, it should be kept away from the eyes and mouth. If your hand touches liquid crystal, wash your hand thoroughly with water and soap as soon as possible.

10. MECHANICAL DRAWING

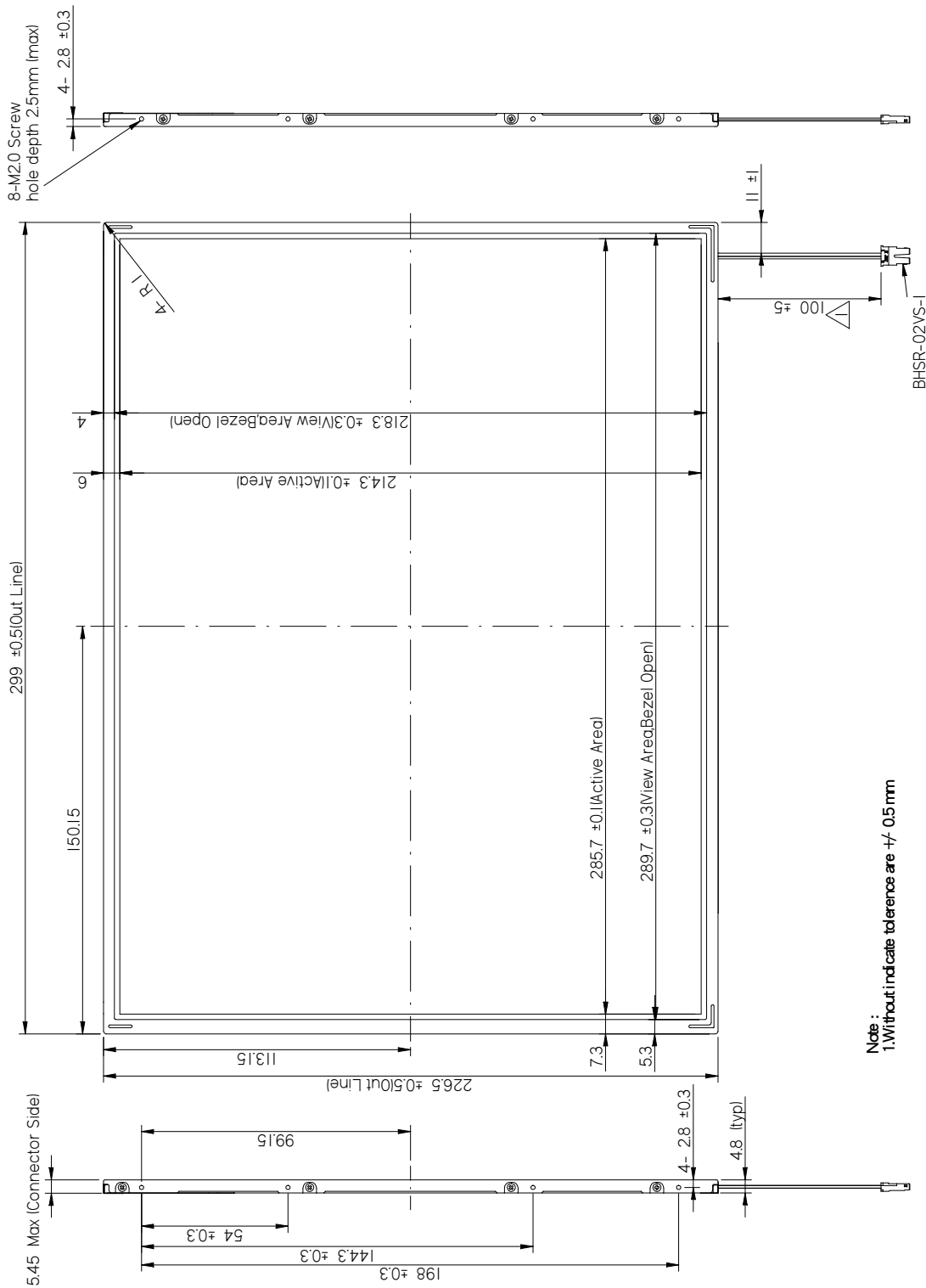

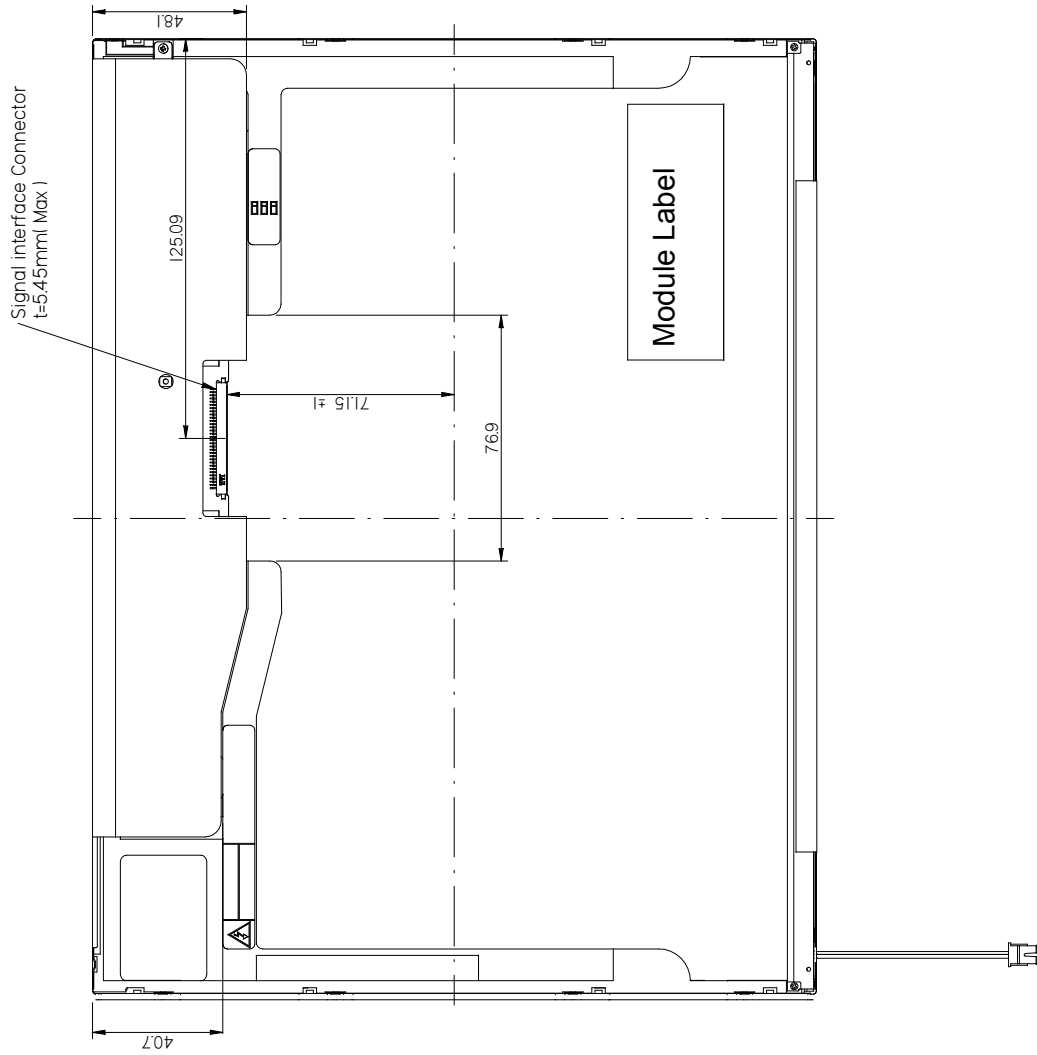

Note :  
1. Without indicate tolerance are +/- 0.5 mm

11. PACKING DRAWING

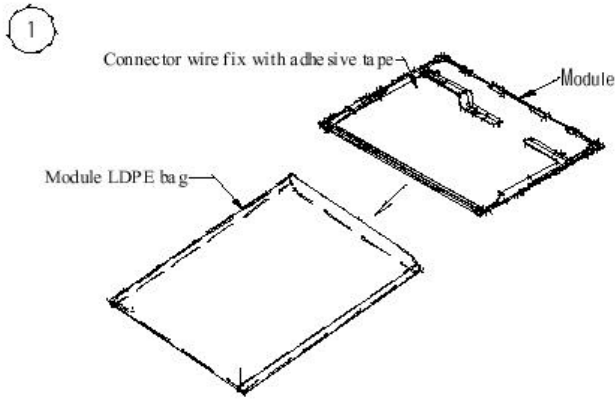

Fig.1



Fig.2

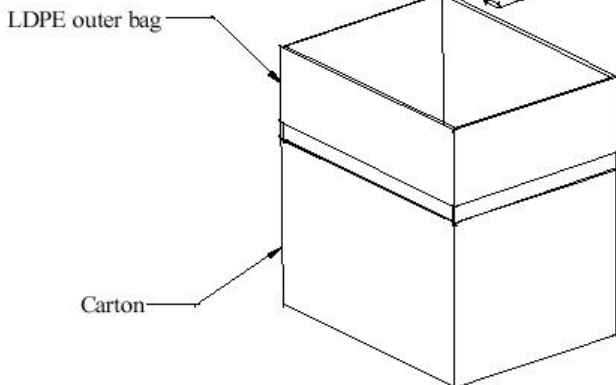
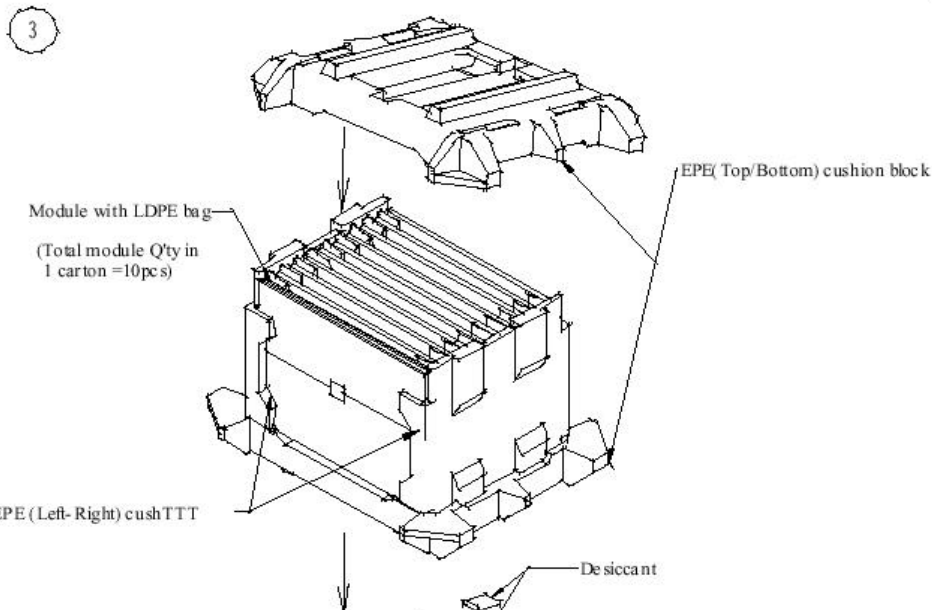

Fig.3

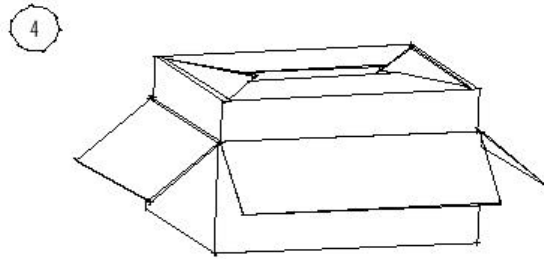

Fig.4

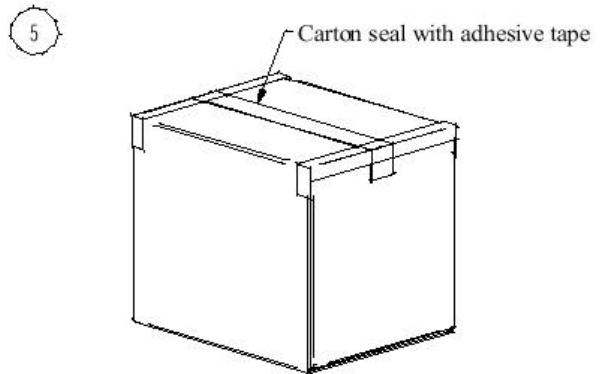

Fig.5

**TD141TGCD1 module delivery packing method**

- (1). Module connector wire fixed with adhesive tape as Fig.1, then pack into module LDPE bag.
- (2). LDPE bag opening (with module inside) fix with adhesive tape as Fig.2.
- (3). The Module insert into EPE assembly cushion as Fig.3, then pack into carton (carton inside wrap with LDPE bag and put 2pcs desiccant)
- (4). Fold the LDPE bag opening closed properly as Fig.4.
- (5). Seal the carton with adhesive tape.

## Appendix1 EDID

### Header

Byte(dec)	Byte(hex)	Field Name and Comments	Value(hex)	Value(binary)
0	00	Header	00	0000 0000
1	01	Header	FF	1111 1111
2	02	Header	FF	1111 1111
3	03	Header	FF	1111 1111
4	04	Header	FF	1111 1111
5	05	Header	FF	1111 1111
6	06	Header	FF	1111 1111
7	07	Header	00	0000 0000

Byte(dec)	Byte(hex)	Field Name and Comments	Value(hex)	Value(binary)
8	08	ID Manufacturer Name	51	0101 0001
9	09		E3	1110 0011
10	0A	ID Product Code	AD	1010 1101
11	0B		1C	0001 1100
12	0C	32-bit serial no.	00	0000 0000
13	0D		00	0000 0000
14	0E		00	0000 0000
15	0F		00	0000 0000
16	10	Week of manufacture	00	0000 0000
17	11	Year of manufacture	00	0000 0000
18	12	EDID Structure Ver.	01	0000 0001
19	13	EDID revision #	02	0000 0010

Byte(dec)	Byte(hex)	Field Name and Comments	Value(hex)	Value(binary)
20	14	Video input definition	80	1000 0000
21	15	Max H image size	1D	0001 1101
22	16	Max V image size	15	0001 0101
23	17	Display Gamma	78	0111 1000
24	18	Feature support	08	0000 1000

Byte(dec)	Byte(hex)	Field Name and Comments	Value(hex)	Value(binary)
25	19	Red / green low bits	E7	1110 0111
26	1A	Blue / white low bits	B5	1011 0101
27	1B	Red x / high bits	93	1001 0011

28	1C	Red y	56	0101 0110
29	1D	Green x	4F	0100 1111
30	1E	Green y	8D	1000 1101
31	1F	Blue x	28	0010 1000
32	20	Blue y	1F	0001 1111
33	21	White x	50	0101 0000
34	22	White y	54	0101 0100
35	23	Established timing 1	00	0000 0000
36	24	Established timing 2	08	0000 1000
37	25	Established timing 3	00	0000 0000

Byte(dec)	Byte(hex)	Field Name and Comments	Value(hex)	Value(binary)
38	26	Standard timing #1	01	0000 0001
39	27		01	0000 0001
40	28	Standard timing #2	01	0000 0001
41	29		01	0000 0001
42	2A	Standard timing #3	01	0000 0001
43	2B		01	0000 0001
44	2C	Standard timing #4	01	0000 0001
45	2D		01	0000 0001
46	2E	Standard timing #5	01	0000 0001
47	2F		01	0000 0001
48	30	Standard timing #6	01	0000 0001
49	31		01	0000 0001
50	32	Standard timing #7	01	0000 0001
51	33		01	0000 0001
52	34	Standard timing #8	01	0000 0001
53	35		01	0000 0001

Byte(dec)	Byte(hex)	Field Name and Comments	Value(hex)	Value(binary)
54	36	Pixel Clock/10,000 (LSB)	64	0110 0100
55	37	Pixel Clock/10,000 (MSB)	19	0001 1001
56	38	Horizontal Active=xxxx pixels (lower 8 bits)	00	0000 0000
57	39	Horizontal Blanking=xxxx pixels (lower 8 bits)	28	0010 1000
58	3A	Horizontal Active/Horizontal Blanking(Thbp)	41	0100 0001
59	3B	Vertical Active =xxxx lines	00	0000 0000
60	3C	Vertical Blanking(Tvbp)=xxxx lines(DE Blanking min for	23	0010 0011

The information contained herein is the exclusive property of toppoly Optoelectronics corporation, and shall not be distributed, reproduced, or disclosed in whole or in part without prior written permission of toppoly Optoelectronics corporation.

		DE only panels)		
61	3D	Vertical Active : Vertical Blanking(Tvbp) (upper4:4bits)	30	0011 0000
62	3E	Horizontal Sync, Offset (Thfp)=xxxx pixels	18	0001 1000
63	3F	Horizontal Sync, Pulse Width=xxxx pixels	88	1000 1000
64	40	Vertical Sync,Offset (Tvfp)=xx lines Sync Width=xx lines	36	0011 0110
65	41	Horizontal Vertical Sync Offset / Width upper 2 bits	00	0000 0000
66	42	Horizontal Image Size=xxx mm	1E	0001 1110
67	43	Vertical image Size=xxx mm	D6	1101 0110
68	44	Horizontal Image Size / Vertical image size	10	0001 0000
69	45	Horizontal Border = 0 (Zero for Notebook LCD)	00	0000 0000
70	46	Vertical Border = 0 (Zero for Notebook LCD)	00	0000 0000
71	47	EDID Standard	18	0001 1000
72	48	Flag	00	0000 0000
73	49	Flag	00	0000 0000
74	4A	Flag	00	0000 0000
75	4B	Data Type Tag: Descriptor Defined by Manufacturer	0F	0000 1111
76	4C	Flag	00	0000 0000
77	4D	Value=HSPW <sub>min</sub> /2	00	0000 0000
78	4E	Value=HSPW <sub>max</sub> /2	00	0000 0000
79	4F	Value=Thbp <sub>min</sub> /2	00	0000 0000
80	50	Value=Thbp <sub>min</sub> /2	00	0000 0000
81	51	Value=VSPW <sub>min</sub> /2	00	0000 0000
82	52	Value=VSPW <sub>min</sub> /2	00	0000 0000
83	53	Value=Tvbp <sub>min</sub> /2	00	0000 0000
84	54	Value=Tvbp <sub>min</sub> /2	00	0000 0000
85	55	Thp <sub>min</sub> =value*2+HA <sub>pixel clks</sub>	00	0000 0000
86	56	Thp <sub>max</sub> =value*2+HA <sub>pixel clks</sub>	00	0000 0000
87	57	Tvp <sub>min</sub> =value*2+VA <sub>line</sub>	00	0000 0000
88	58	Tvp <sub>max</sub> =value*2+VA <sub>line</sub>	00	0000 0000
89	59	Module "A" Revision= Example:00,01,02,03,etc	00	0000 0000

Byte(dec)	Byte(hex)	Field Name and Comments	Value(hex)	Value(binary)
90	5A	Flag	00	0000 0000
91	5B	Flag	00	0000 0000
92	5C	Flag	00	0000 0000
93	5D	Dummy Descriptor	FE	1111 1110



94	5E	Flag	00	0000 0000
95	5F		00	0000 0000
96	60		00	0000 0000
97	61		00	0000 0000
98	62		00	0000 0000
99	63		00	0000 0000
100	64		00	0000 0000
101	65		00	0000 0000
102	66		00	0000 0000
103	67		00	0000 0000
104	68		00	0000 0000
105	69		00	0000 0000
106	6A		00	0000 0000
107	6B		00	0000 0000
108	6C	Flag	00	0000 0000
109	6D	Flag	00	0000 0000
110	6E	Flag	00	0000 0000
111	6F		FE	1111 1110
112	70	Flag	00	0000 0000
113	71		00	0000 0000
114	72		00	0000 0000
115	73		00	0000 0000
116	74		00	0000 0000
117	75		00	0000 0000
118	76		00	0000 0000
119	77		00	0000 0000
120	78		00	0000 0000
121	79		00	0000 0000
122	7A		00	0000 0000
123	7B		00	0000 0000
124	7C		00	0000 0000
125	7D		00	0000 0000
126	7E	Extension flag	00	0000 0000
127	7F	Checksum	00	0000 0000

### Module Label Drawing & Definition

The module Label Drawing & Definition illustration as below:

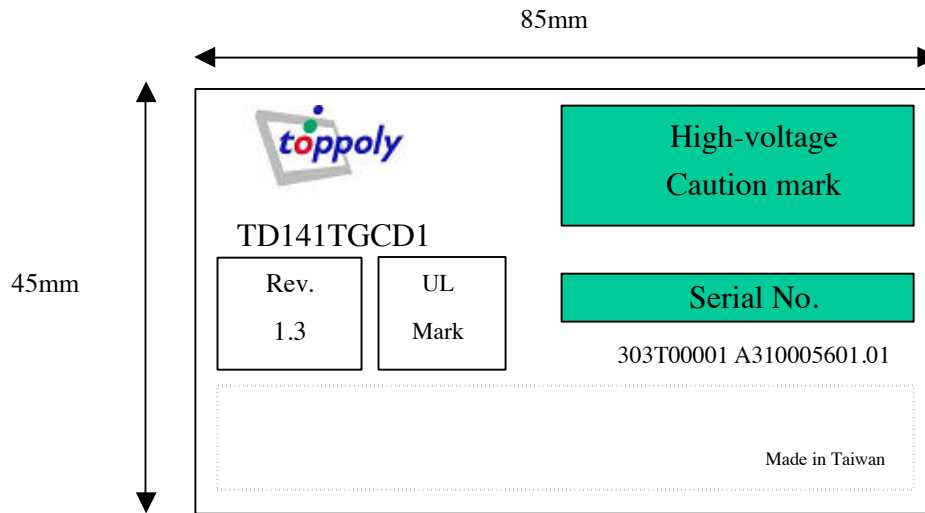

(a) Module Name: TD141TGCD1

(b) Revision: Product Revision of customer, for example Rev.1.3

(c) Serial No.: There are 9 symbols as below, Year + Week (2 numbers) + Factory + 5numbers

(1) Year is the last number of A.D

(2) The expression of Week is 01 ~ 53 in order.

(3) The expression of Factory is one English letter, T for TP01 and N for NJ.

(4) The order of sequential number is 00001~99999 → A0001~A9999 → B0001~B9999 → and so on.