

## HIGH-PERFORMANCE, LOW-CURRENT US SIGFOX™ GATEWAY

### Features

- SIGFOX Ready™
- Frequency range = ITU Region 2 ISM Band (Americas, 902~928 MHz)
- Receive sensitivity = -127 dBm
- Modulation
  - (G)FSK, 4(G)FSK, GMSK
  - OOK
- Max output power
  - +24 dBm
- Low active radio power consumption
  - 21 mA RX
  - 230 mA TX @ +23 dBm
- Power supply = 2.3 to 3.6 V
- LGA25 (25.4x12.7x3.81mm, 1"x0.5"x0.15") Land Grid Array package
- Available in several conditioning methods

### Applications

- SIGFOX™ transceiver (fully certified)
- Sensor network
- Health monitors
- Remote control
- Home security and alarm
- Telemetry
- Industrial control

### Description

TD next's TD1508 devices are high performance, low current SIGFOX™ gateways. The combination of a powerful radio transceiver and a state-of-the-art ARM Cortex M3 baseband processor achieves extremely high performance while maintaining ultra-low active and standby current consumption. The TD1508 device offers an outstanding RF sensitivity of -127 dBm while providing an exceptional output power of up to +23 dBm with unmatched TX efficiency. The TD1508 device versatility provides the gateway function from a local Narrow Band ISM network to the long-distance Ultra Narrow Band SIGFOX™ network at no additional cost. The broad range of analog and digital interfaces available in the TD1508 module allows any application to interconnect easily to the SIGFOX™ network. The LVTTTL low-energy UART, the I<sup>2</sup>C and SPI buses, the multiple timers with pulse count input/quadrature decoding/PWM output capabilities, the high-resolution/high-speed ADC and DAC, along with the numerous GPIOs can control any kind of external sensors or activators. Featuring an AES encryption engine and a DMA controller, the powerful 32-bit ARM Cortex-M3 baseband processor can implement highly complex and secure protocols in an efficient environmental and very low consumption way.

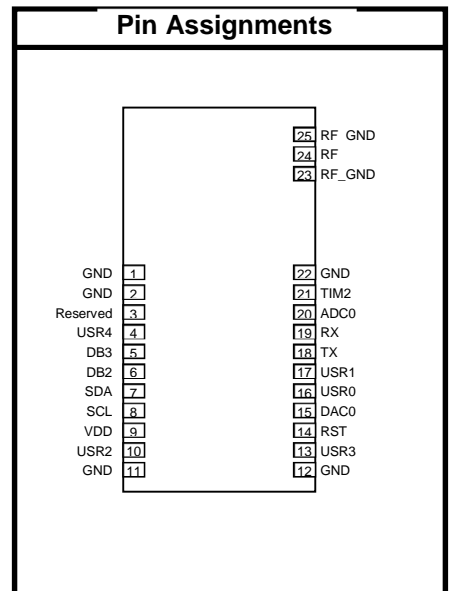

Patents pending

**Disclaimer:** The information in this document is provided in connection with Telecom Design products. No license, express or implied, by estoppel or otherwise, to any intellectual property right is granted by this document or in connection with the sale of Telecom Design products.

TELECOM DESIGN ASSUMES NO LIABILITY WHATSOEVER AND DISCLAIMS ANY EXPRESS, IMPLIED OR STATUTORY WARRANTY RELATING TO ITS PRODUCTS INCLUDING, BUT NOT LIMITED TO, THE IMPLIED WARRANTY OF MERCHANTABILITY, FITNESS FOR A PARTICULAR PURPOSE, OR NON-INFRINGEMENT. IN NO EVENT SHALL TELECOM DESIGN BE LIABLE FOR ANY DIRECT, INDIRECT, CONSEQUENTIAL, PUNITIVE, SPECIAL OR INCIDENTAL DAMAGES (INCLUDING, WITHOUT LIMITATION, DAMAGES FOR LOSS OF PROFITS, BUSINESS INTERRUPTION, OR LOSS OF INFORMATION) ARISING OUT OF THE USE OR INABILITY TO USE THIS DOCUMENT, EVEN IF TELECOM DESIGN HAS BEEN ADVISED OF THE POSSIBILITY OF SUCH DAMAGES.

Telecom Design makes no representations or warranties with respect to the accuracy or completeness of the contents of this document and reserves the right to make changes to specifications and product descriptions at any time without notice. Telecom Design does not make any commitment to update the information contained herein. Unless specifically provided otherwise, Telecom Design products are not suitable for, and shall not be used in, automotive applications. Telecom Design products are not intended, authorized, or warranted for use as components in applications intended to support or sustain life.

© 2015-2016 Telecom Design S.A. All rights reserved. Telecom Design®, logo and combinations thereof, are registered trademarks of Telecom Design S.A. SIGFOX™ is a trademark of SigFox S.A. ARM®, the ARM Powered® logo and others are the registered trademarks or trademarks of ARM Ltd. I2C™ is a trademark of Koninklijke Philips Electronics NV. Other terms and product names may be trademarks of others.

Functional Block Diagram

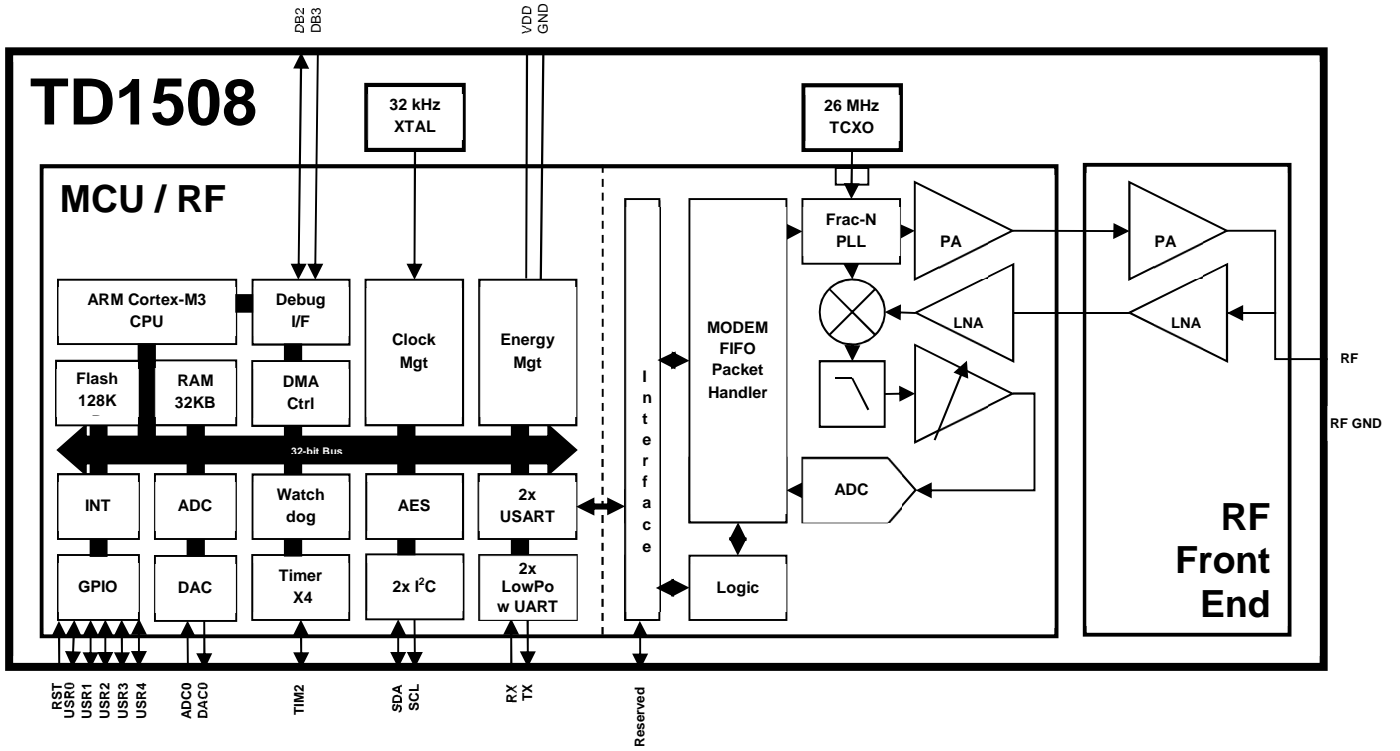

<u>Section</u>	<u>Page</u>
<b>1 Electrical Specifications .....</b>	<b>6</b>
1.1 Definition of Test Conditions.....	15
<b>2 Functional Description .....</b>	<b>16</b>
<b>3 Module Interface .....</b>	<b>18</b>
3.1 Low-Power UART (Universal Asynchronous Receiver/Transmitter).....	18
3.2 USART (Universal Synchronous/Asynchronous Receiver/Transmitter) .....	18
3.3 I <sup>2</sup> C bus.....	18
3.4 Timer/Counter .....	19
3.5 ADC (Analog to Digital Converter).....	19
3.6 DAC (Digital to Analog Converter).....	19
3.7 GPIO (General Purpose Input/Output).....	20
3.8 RST (Reset).....	20
3.9 Debug.....	20
3.10 RF Antenna.....	20
3.11 VDD & GND.....	20
<b>4 Bootloader.....</b>	<b>21</b>
<b>5 Pin Descriptions .....</b>	<b>22</b>
<b>6 I/O alternate functionalities.....</b>	<b>24</b>
<b>7 Ordering Information.....</b>	<b>26</b>
<b>8 Package Outline.....</b>	<b>27</b>
<b>9 PCB Land Pattern .....</b>	<b>28</b>
<b>10 Soldering Information .....</b>	<b>29</b>
10.1 Solder Stencil.....	29
10.2 Reflow soldering profile.....	29
<b>11 Board Mounting Recommendation .....</b>	<b>30</b>
11.1 Electrical Environment.....	30
11.2 Power Supply Decoupling .....	30
11.3 RF Layout Considerations .....	30
11.4 Host Antenna Circuit Trace Design .....	30
<b>12 Conformity Assessment Issues / FCC Regulatory Notices .....</b>	<b>35</b>
12.1 Modification Statement .....	35
12.2 Interference Statement.....	35

---

12.3 Wireless Notice .....35

12.4 FCC Class B Digital Device Notice.....35

12.5 Labelling Requirements for the Host Device .....35

# TD1508

## 1 Electrical Specifications

Table 1. Absolute Maximum Ratings

Parameter	Value	Units
V <sub>DD</sub> to GND	0 to +3.6	V
Instantaneous V <sub>RF-peak</sub> to GND on RF Pin	-0.3 to +8.0	V
Sustained V <sub>RF-peak</sub> to GND on RF Pin	-0.3 to +6.5	V
Voltage on Digital Inputs	0 to V <sub>DD</sub>	V
Voltage on Analog Inputs	0 to V <sub>DD</sub>	V
RX Input Power	+10	dBm
Operating Ambient Temperature Range T <sub>A</sub>	-30 to +75	°C
Storage Temperature Range T <sub>STG</sub>	-40 to +125	°C
Maximum soldering Temperature	260	°C

**Note:**

Stresses beyond those listed under “Absolute Maximum Ratings” may cause permanent damage to the device. These are stress ratings only and functional operation of the device at or beyond these ratings in the operational sections of the specifications is not implied. Exposure to absolute maximum rating conditions for extended periods may affect device reliability. Power Amplifier may be damaged if switched on without proper load or termination connected. TX matching network design will influence TX V<sub>RF-peak</sub> on RF pin. Caution: ESD sensitive device.

Table 2- DC Power Supply Characteristics<sup>1</sup>

Parameter	Symbol	Conditions	Min	Typ	Max	Units
Supply Voltage Range <sup>2</sup>	V <sub>DD</sub>		2.3	3.0	3.6	V
Power Saving Mode <sup>2</sup>	I <sub>Sleep</sub>	Sleep current using the 32 kHz crystal @ 25°C	1.5	1.8	3.5	μA
Active CPU Mode	I <sub>Active</sub>	CPU performing active loop @ 14 MHz	2.55	3.0	3.45	mA
Active CPU Mode + RX Mode Current <sup>2</sup>	I <sub>RX</sub>		—	13	16	mA
Active CPU Mode + TX Mode Current <sup>2</sup>	I <sub>TX_+24</sub>	+24 dBm output power, 902.8 MHz, 3.3 V	—	240	—	mA
	I <sub>TX_+23</sub>	+23 dBm output power, 902.8 MHz, 3.3 V	—	230	—	mA
	I <sub>TX_+22</sub>	+22 dBm output power, 902.8 MHz, 3.3 V	—	200	—	mA
	I <sub>TX_+20</sub>	+20 dBm output power, 902.8 MHz, 3.3 V	—	180	—	mA
	I <sub>TX_+15</sub>	+15 dBm output power, 902.8 MHz, 3.3 V	—	135	—	mA

**Notes:**

1. All specifications guaranteed by production test unless otherwise noted. Production test conditions and max limits are listed in the “Production Test Conditions” section in “1.1. Definition of Test Conditions” on page 5.
2. Guaranteed by qualification. Qualification test conditions are listed in the “Qualification Test Conditions” section in “1.1. Definition of Test Conditions” on page 14.

**Table 3. Transmitter RF Characteristics<sup>1</sup>**

Parameter	Symbol	Conditions	Min	Typ	Max	Units
TX Frequency Range <sup>2</sup>	$F_{TX}$		902.0	—	928	MHz
Modulation Deviation Range <sup>3</sup>	$\Delta f$	902.0-928.0 MHz	—	1.5	—	MHz
Modulation Deviation Resolution <sup>3</sup>	$F_{RES}$	902.0-928.0 MHz	—	28.6	—	Hz
Frequency Error <sup>2</sup>	$F_{ERR\_25}$	902.0-928.0 MHz, 25°C, 3.3 V	—	±2	—	kHz
	$F_{ERR\_M20}$	902.0-928.0 MHz, -20°C, 3.3 V	—	±3	—	kHz
	$F_{ERR\_55}$	902.0-928.0 MHz, 55°C, 3.3 V	—	±3	—	kHz
Average Conducted Power <sup>2</sup>	$P_{AVCDP}$	-20°C to 55°C, 902.0-928.0 MHz, 3.3 V	—	—	+25	dBm

**Notes:**

3. All specifications guaranteed by production test unless otherwise noted. Production test conditions and max limits are listed in the “Production Test Conditions” section of “1.1. Definition of Test Conditions” on page 5.
4. Guaranteed by qualification. Qualification test conditions are listed in the “Qualification Test Conditions” section in “1.1. Definition of Test Conditions” on page 14.
5. Guaranteed by component specification.



Table 4. Receiver RF Characteristics<sup>1</sup>

Parameter	Symbol	Conditions	Min	Typ	Max	Units
RX Frequency Range <sup>2</sup>	F <sub>RX</sub>		902.0	—	928.0	MHz
Synthesizer Frequency Resolution <sup>3</sup>	F <sub>RES</sub>	902.0-928.0 MHz	—	28.6	—	Hz
Blocking <sup>2,4</sup>	1M <sub>BLOCK</sub>	Frequency offset ± 1 MHz, 902.0-928.0 MHz, 25°C, 3.3 V	—	-79	-68	dB
	8M <sub>BLOCK</sub>	Frequency offset ± 10 MHz, 902.0-928.0 MHz, 25°C, 3.3 V	—	-86	-75	dB
Spurious Emissions <sup>2</sup>	P <sub>OB_RX1</sub>	From 9 kHz to 1 GHz, 902.0-928.0 MHz, 25°C, 3.3 V	—	-84	—	dBm
	P <sub>OB_RX2</sub>	From 1 GHz to 6 GHz, 902.0-928.0 MHz, 25°C, 3.3 V	—	-70	—	dBm
RX Sensitivity <sup>3</sup>	P <sub>RX_0.5</sub>	(BER < 0.1%) (500 bps, GFSK, BT = 0.5, Δf = ±250 Hz)	—	-127	—	dBm
	P <sub>RX_40</sub>	(BER < 0.1%) (40 kbps, GFSK, BT = 0.5, Δf = ±20 kHz)	—	-110	—	dBm
	P <sub>RX_100</sub>	(BER < 0.1%) (100 kbps, GFSK, BT = 0.5, Δf = ±50 kHz)	—	-104	-102	dBm
	P <sub>RX_125</sub>	(BER < 0.1%) (125 kbps, GFSK, BT = 0.5, Δf = ±62.5 kHz)	—	-105	—	dBm
	P <sub>RX_500</sub>	(BER < 0.1%) (500 kbps, GFSK, BT = 0.5, Δf = ±250 kHz)	—	-97	-92	dBm
	P <sub>RX_9.6</sub>	(BER < 0.1%) (9.6 kbps, GFSK, BT = 0.5, Δf = ±2.4 kHz)	—	-110	—	dBm
	P <sub>RX_1M</sub>	(BER < 0.1%) (1 Mbps, GFSK, BT = 0.5, Δf = ±1.25 kHz)	—	-88	—	dBm
	P <sub>RX_OOK</sub>	(BER < 0.1%, 4.8 kbps, 350 kHz BW, OOK, PN15 data)	—	-108	-104	dBm
		(BER < 0.1%, 40 kbps, 350 kHz BW, OOK, PN15 data)	—	-101	-97	dB
(BER < 0.1%, 120 kbps, 350 kHz BW, OOK, PN15 data)		—	-96	-91	dBm	
RSSI Resolution <sup>3</sup>	RES <sub>RSSI</sub>		—	±0.5	—	dB

**Notes:**

1. All specifications guaranteed by production test unless otherwise noted. Production test conditions and max limits are listed in the “Production Test Conditions” section of “1.1. Definition of Test Conditions” on page 5.
2. Guaranteed by qualification. Qualification test conditions are listed in the “Qualification Test Conditions” section in “1.1. Definition of Test Conditions” on page 14.
3. Guaranteed by component specification.
4. The typical blocking values were obtained while seeking for EN 300-220 Category 2 compliance only. The typical value specified in the component datasheet are -75 dB and -84 dB at 1 and 8 MHz respectively, with desired reference signal 3 dB above sensitivity, BER = 0.1%, interferer is CW, and desired is modulated with 2.4 kbps, ΔF = 1.2 kHz GFSK with BT = 0.5, RX channel BW = 4.8 kHz. The RF component manufacturer provides a reference design featuring a SAW filter which is EN 300-220 Category 1 compliant. Please contact Telecom Design for more information on EN 300-220 Category 1 compliance.

**Table 5. All Digital I/O (except DB1) DC & AC Characteristics<sup>1</sup>**

Parameter	Symbol	Conditions	Min	Typ	Max	Units
Input Low Voltage <sup>2</sup>	V <sub>IOIL</sub>		—	—	0.3V <sub>DD</sub>	V
Input High Voltage <sup>2</sup>	V <sub>IOIH</sub>		0.7V <sub>DD</sub>	—	—	V
Output High Voltage <sup>2</sup>	V <sub>IOOH</sub>	Sourcing 6 mA, VDD = 3.0V, Standard Drive Strength	0.85V <sub>DD</sub>	—	—	V
		Sourcing 20 mA, VDD = 3.0V, High Drive Strength	0.8V <sub>DD</sub>	—	—	V
Output Low Voltage <sup>2</sup>	V <sub>IOOL</sub>	Sinking 6 mA, VDD=3.0V, Standard Drive Strength	—	—	0.20V <sub>DD</sub>	V
		Sinking 20 mA, VDD=3.0V, High Drive Strength	—	—	0.25V <sub>DD</sub>	V
Input Leakage Current <sup>2</sup>	I <sub>IOLEAK</sub>	High Impedance I/O connected to GND or V <sub>DD</sub>	—	±0.1	±100	nA
I/O Pin Pull-Up Resistor <sup>2</sup>	R <sub>PU</sub>		—	40	—	kΩ
I/O Pin Pull-Down Resistor <sup>2</sup>	R <sub>PD</sub>		—	40	—	kΩ
Internal ESD Series Resistor <sup>2</sup>	R <sub>IOESD</sub>		—	200	—	Ω
Pulse Width of Pulses to be removed by the Glitch Suppression Filter <sup>2</sup>	t <sub>IOGLITCH</sub>		10	—	—	ns
Output Fall Time <sup>2</sup>	t <sub>IOOF</sub>	0.5 mA Drive Strength and Load Capacitance C <sub>L</sub> = 12.5 to 25 pF	20+0.1C <sub>L</sub>	—	250	ns
		2 mA Drive Strength and Load Capacitance C <sub>L</sub> = 350 to 600 pF	20+0.1C <sub>L</sub>	—	250	ns
I/O Pin Hysteresis (V <sub>IOTHR+</sub> - V <sub>IOTHR-</sub> ) <sup>2</sup>	V <sub>IOHYST</sub>	V <sub>DD</sub> = 2.3 to 3.3 V	0.1V <sub>DD</sub>	—	—	V

**Notes:**

- All specifications guaranteed by production test unless otherwise noted. Production test conditions and max limits are listed in the “Production Test Conditions” section of “1.1. Definition of Test Conditions” on page 14.
- Guaranteed by component specification.

Table 6. DB1 Digital I/O DC & AC Characteristics<sup>1</sup>

Parameter	Symbol	Conditions	Min	Typ	Max	Units
Input Low Voltage <sup>2</sup>	$V_{DB1IL}$		—	—	$0.3V_{DD}$	V
Input High Voltage <sup>2</sup>	$V_{DB1IH}$		$0.7V_{DD}$	—	—	V
Output High Voltage <sup>2</sup>	$V_{DB1OH}$	Sourcing 7.4 mA, $V_{DD} = 3.3V$ , Drive Strength = HL	$0.8V_{DD}$	—	—	V
Output Low Voltage <sup>2</sup>	$V_{DB1OL}$	Sinking 8.5 mA, $V_{DD} = 3.3V$ , Drive Strength = HL	—	—	$0.2V_{DD}$	V
Input Leakage Current <sup>2</sup>	$I_{DB1LEAK}$	High Impedance I/O connected to GND or $V_{DD}$	—	—	1	$\mu A$
Input Capacitance <sup>2</sup>	$C_{DB1IN}$		—	2	—	pF
Output Rise Time <sup>2</sup>	$t_{DB1OR}$	$0.1V_{DD}$ to $0.9V_{DD}$ , $C_L = 10$ pF, Drive Strength = LL	—	2.3	—	ns
Output Fall Time <sup>2</sup>	$t_{DB1OF}$	$0.9V_{DD}$ to $0.1V_{DD}$ , $C_L = 10$ pF, Drive Strength = LL	—	2	—	ns

**Notes:**

1. All specifications guaranteed by production test unless otherwise noted. Production test conditions and max limits are listed in the “Production Test Conditions” section of “1.1. Definition of Test Conditions” on page 14.
2. Guaranteed by component specification.

**Table 7. ADC DC & AC Characteristics<sup>1</sup>**

Parameter	Symbol	Conditions	Min	Typ	Max	Units
Input Voltage Range <sup>2</sup>	V <sub>ADCIN</sub>	Single Ended	0	—	V <sub>REF</sub>	V
		Differential	-V <sub>REF/2</sub>	—	V <sub>REF/2</sub>	V
Common Mode Input Range <sup>2</sup>	V <sub>ADCCMIN</sub>		0	—	V <sub>DD</sub>	V
Input Current <sup>2</sup>	I <sub>ADCIN</sub>	2 pF Sampling Capacitors	—	<100	—	nA
Analog Input Common Mode Rejection Ratio <sup>2</sup>	CMRR <sub>ADC</sub>		—	65	—	dB
Average Active Current <sup>2</sup>	I <sub>ADC</sub>	10 ksps/s 12 bit, Internal 1.25 V Reference, Warmup Mode = 0	—	67	—	μA
		10 ksps/s 12 bit, Internal 1.25 V Reference, Warmup Mode = 1	—	63	—	μA
		10 ksps/s 12 bit, Internal 1.25 V Reference, Warmup Mode = 2	—	64	—	μA
Current Consumption of Internal Voltage Reference <sup>2</sup>	I <sub>ADCREF</sub>		—	65	—	μA
Input Capacitance <sup>2</sup>	C <sub>ADCIN</sub>		—	2	—	pF
Input ON Resistance <sup>2</sup>	R <sub>ADCIN</sub>		1	—	—	MΩ
Input RC Filter Resistance <sup>2</sup>	R <sub>ADCFILT</sub>		—	10	—	kΩ
Input RC Filter/Decoupling Capacitance <sup>2</sup>	C <sub>ADCFILT</sub>		—	250	—	fF
ADC Clock Frequency <sup>2</sup>	f <sub>ADCCLK</sub>		—	—	13	MHz
Conversion Time <sup>2</sup>	t <sub>ADCCONV</sub>	6 bit	7	—	—	ADC CLK Cycles
		10 bit	11	—	—	ADC CLK Cycles
		12 bit	13	—	—	ADC CLK Cycles
Acquisition Time <sup>2</sup>	t <sub>ADCACQ</sub>	Programmable	1	—	256	ADC CLK Cycles
Required Acquisition Time for V <sub>DD/3</sub> Reference <sup>2</sup>	t <sub>ADCACQVDD3</sub>		2	—	—	μs
<b>Notes:</b>						
1. All specifications guaranteed by production test unless otherwise noted. Production test conditions and max limits are listed in the “Production Test Conditions” section of “1.1. Definition of Test Conditions” on page 14.						
2. Guaranteed by component specification.						

Table 7. ADC DC & AC Characteristics<sup>1</sup> (continued)

Parameter	Symbol	Conditions	Min	Typ	Max	Units
Startup Time of Reference Generator and ADC Core in NORMAL Mode <sup>2</sup>	t <sub>ADCSTART</sub>		—	5	—	μs
Startup Time of Reference Generator and ADC Core in KEEPADCWARM Mode <sup>2</sup>			—	1	—	μs
Offset Voltage <sup>2</sup>	V <sub>ADCOFFSET</sub>	After calibration, single ended	-3.5	0.3	3	mV
		After calibration, differential	—	0.3	—	mV
Thermometer Output Gradient <sup>2</sup>	TGRAD <sub>AD</sub> CTH		—	-1.92	—	mV/°C
			—	-6.3	—	ADC Codes / °C
Differential Non-Linearity (DNL) <sup>2</sup>	DNL <sub>ADC</sub>		—	±0.7	—	LSB
Integral Non-Linearity (INL), End Point Method <sup>2</sup>	INL <sub>ADC</sub>		—	±1.2	—	LSB
No Missing Codes <sup>2</sup>	MC <sub>ADC</sub>		11.999 <sup>3</sup>	12	—	bits
Gain Error Drift <sup>2</sup>	GAIN <sub>ED</sub>	1.25V Reference	—	0.01 <sup>4</sup>	0.033 <sup>5</sup>	%/°C
		2.5V Reference	—	0.01 <sup>4</sup>	0.03 <sup>5</sup>	%/°C
		1.25V Reference	—	0.2 <sup>4</sup>	0.07 <sup>5</sup>	LSB/°C
		2.5V Reference	—	0.2 <sup>4</sup>	0.62 <sup>5</sup>	LSB/°C

**Notes:**

- All specifications guaranteed by production test unless otherwise noted. Production test conditions and max limits are listed in the “Production Test Conditions” section of “1.1. Definition of Test Conditions” on page 14.
- Guaranteed by component specification.
- On the average every ADC will have one missing code, most likely to appear around 2048 +/- n\*512 where n can be a value in the set {-3, -2, -1, 1, 2, 3}. There will be no missing code around 2048, and in spite of the missing code the ADC will be monotonic at all times so that a response to a slowly increasing input will always be a slowly increasing output. Around the one code that is missing, the neighbor codes will look wider in the DNL plot. The spectra will show spurs on the level of -78dBc for a full scale input for chips that have the missing code issue.
- Typical numbers given by abs(Mean) / (85 - 25).
- Max number given by (abs(Mean) + 3x stddev) / (85 - 25).

**Table 8. DAC DC & AC Characteristics<sup>1</sup>**

Parameter	Symbol	Conditions	Min	Typ	Max	Units
Output Voltage Range <sup>2</sup>	$V_{DACOUT}$	$V_{DD}$ voltage reference, Single Ended	0	—	$V_{DD}$	V
Output Common Mode Voltage Range <sup>2</sup>	$V_{DACCM}$		0	—	$V_{DD}$	V
Active Current Including References for 2 Channels <sup>2</sup>	$I_{DAC}$	500 ksps/s 12 bit	—	400	—	$\mu A$
		500 ksps/s 12 bit	—	200	—	$\mu A$
		1 ksps/s 12 bit NORMAL	—	17	—	$\mu A$
Sample Rate <sup>2</sup>	$SR_{DAC}$		—	—	500	ksps
DAC Clock Frequency <sup>2</sup>	$f_{DAC}$	Continuous Mode	—	—	1000	kHz
		Sample/Hold Mode			250	kHz
		Sample/Off Mode			250	kHz
Clock Cycles per Conversion <sup>2</sup>	$CYC_{DACCONV}$		—	2	—	DAC CLK Cycles
Conversion Time <sup>2</sup>	$t_{DACCONV}$		2	—	—	$\mu s$
Settling Time <sup>2</sup>	$t_{DACSETTLE}$		—	5	—	$\mu s$
Signal to Noise Ratio (SNR) <sup>2</sup>	$SNR_{DAC}$	500 ksps, 12 bit, single ended, internal 1.25V reference	—	58	—	dB
		500 ksps, 12 bit, single ended, internal 2.5V reference	—	59	—	dB
Signal to Noise-Pulse Distortion Ratio (SNDR) <sup>2</sup>	$SNDR_{DAC}$	500 ksps, 12 bit, single ended, internal 1.25V reference	—	57	—	dB
		500 ksps, 12 bit, single ended, internal 2.5V reference	—	54	—	dB
Spurious-Free Dynamic Range(SFDR) <sup>2</sup>	$SFDR_{DAC}$	500 ksps, 12 bit, single ended, internal 1.25V reference	—	62	—	dB
		500 ksps, 12 bit, single ended, internal 2.5V reference	—	56	—	dB
Offset Voltage <sup>2</sup>	$V_{DACOFFSET}$	After calibration, single ended	—	2	9	mV
Differential Non-Linearity <sup>2</sup>	$DNL_{DAC}$		—	$\pm 1$	—	LSB
Integral Non-Linearity <sup>2</sup>	$INL_{DAC}$		—	$\pm 5$	—	LSB
No Missing Codes <sup>2</sup>	$MC_{DAC}$		—	12	—	bits

**Notes:**

1. All specifications guaranteed by production test unless otherwise noted. Production test conditions and max limits are listed in the “Production Test Conditions” section of “1.1. Definition of Test Conditions” on page 14.
2. Guaranteed by component specification.

## 1.1 Definition of Test Conditions

### 1.1.1 Production Test Conditions:

- $T_A = + 25^{\circ}\text{C}$
- $V_{DD} = +3.3 \text{ VDC}$
- Production test schematics (unless noted otherwise)
- All RF input and output levels referred to the pins of the TD1508 module

### 1.1.2 Qualification Test Conditions:

- $T_A = -30 \text{ to } +75^{\circ}\text{C}$  (Typical  $T_A = 25^{\circ}\text{C}$ )
- $V_{DD} = +2.3 \text{ to } 3.6 \text{ VDC}$  (Typical  $V_{DD} = 3.0 \text{ VDC}$ )
- Using TX/RX Split Antenna reference design or production test schematic
- All RF input and output levels referred to the pins of the TD1508 module

# TD1508

## 2 Functional Description

---

The TD1508 devices are high-performance, low-current, wireless SIGFOX™ gateways. The wide operating voltage range of 2.3–3.3 V and low current consumption make the TD1508 an ideal solution for battery powered applications. The TD1508 operates as a time division duplexing (TDD) transceiver where the device alternately transmits and receives data packets. The device uses a single-conversion mixer to downconvert the 2-level FSK/GFSK or OOK/ASK modulated receive signal to a low IF frequency. Following a programmable gain amplifier (PGA) the signal is converted to the digital domain by a high performance  $\Delta\Sigma$  ADC allowing filtering, demodulation, slicing, and packet handling to be performed in the built-in DSP increasing the receiver's performance and flexibility versus analog based architectures. The demodulated signal is output to the baseband CPU by reading the 64-byte RX FIFO.

A single high precision local oscillator (LO) is used for both transmit and receive modes since the transmitter and receiver do not operate at the same time. The LO is generated by an integrated VCO and  $\Delta\Sigma$  Fractional-N PLL synthesizer. The synthesizer is designed to support configurable data rates from 100bps to 1 Mbps. The TD1508 operates in the frequency bands of 902.0–928.0 MHz with a maximum frequency accuracy step size of 28.6 Hz. The transmit FSK data is modulated directly into the  $\Delta\Sigma$  data stream and can be shaped by a Gaussian low-pass filter to reduce unwanted spectral content.

The power amplifier (PA) supports output power up to +24 dBm with very high efficiency, consuming only 190 mA at +23 dBm. The integrated power amplifier can also be used to compensate for the reduced performance of a lower cost, lower performance antenna or antenna with size constraints due to a small form-factor. The PA is single-ended to allow for easy antenna matching and low BOM cost. The PA incorporates automatic ramp-up and ramp-down control to reduce unwanted spectral spreading. A highly configurable packet handler allows for autonomous encoding/decoding of nearly any packet structure.

As both the local Narrow Band ISM network and the long-distance Ultra Narrow Band SIGFOX™ network can be addressed seamlessly, the TD1508 device provides a natural gateway function at no additional cost. Thus, the same TD1508 module can be used both for local RF communication with peer modules, and also connect to the wide-area SIGFOX™ RF network.

The broad range of analog and digital interfaces available in the TD1508 module allows any application to interconnect easily to the SIGFOX™ network. The LVTTL low-energy UART, the I<sup>2</sup>C and SPI buses, the multiple timers with pulse count input/quadrature decoding/PWM output capabilities, the high-resolution/high-speed ADC and DAC, along with the numerous GPIOs can control any kind of external sensors or activators. Featuring an AES encryption engine and a DMA controller, the powerful 32-bit ARM Cortex-M3 baseband processor can implement highly complex and secure protocols in an efficient environmental and very low consumption way. This unique combination of a powerful 32-bit ARM Cortex-M3 CPU including innovative low energy techniques, short wake-up time from energy saving modes, and a wide selection of intelligent peripherals allows any application to connect to the SIGFOX™ network.

The application shown in Figure 1 shows the minimum interconnection required to operate the TD1508 module.

Basically, only the 5 GND, 2 RF\_GND, V<sub>DD</sub>, TX, RX and RF antenna pin connections are necessary. The RST (reset) pin connection is not mandatory and this pin can be left floating if not used.

A 10  $\mu$ F/6.3V decoupling capacitor must be added as close as possible to the V<sub>DD</sub> pin.

The TX/RX pins are LVTTL-compatible and feature internal pull-up resistors.

A 50  $\Omega$  matched RF antenna must be connected to the RF pin, with a low-capacitance (< 0.5 pF) TVS diode to protect the RF input from ESD transients.

The connection of a super-blue LED with series current-limiting resistor of 220  $\Omega$  on pin TIM2 is recommended in order to display the bootloader status at boot time.



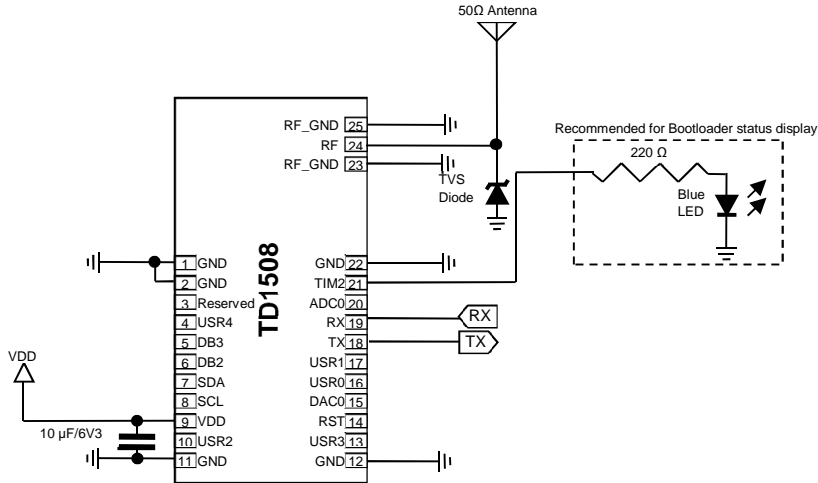

Figure 1. Typical Application

**Note:** The TVS diode used for protecting the RF input against ESD must be of low-capacitance (0.5 pF typical) type, e.g. ESD9R3.3ST5G (On Semiconductor), for example.

## 3 Module Interface

### 3.1 Low-Power UART (Universal Asynchronous Receiver/Transmitter)

The TD1508 communicates with the host MCU over a standard asynchronous serial interface consisting of only 2 pins: TX and RX. The TX pin is used to send data from the TD1508 module to the host MCU, and the RX pin is used to receive data into the TD1508 module coming from the host MCU.

This interface allows two-way UART communication to be performed in low energy modes, using only a few  $\mu\text{A}$  during active communication and only 150 nA when waiting for incoming data.

This serial interface is designed to operate using the following serial protocol parameters:

- LVTTTL electrical level
- 9600 bps
- 8 data bits
- 1 stop bit
- No parity
- No hardware/software flow control

This interface operates using LVTTTL signal levels to satisfy the common interface to a low power host MCU. If an EIA RS232-compliant interface voltage level is required, an RS232 level translator circuit must be used. It is also possible to use a common USB/UART interface chip to connect to an USB bus.

Over this serial interface, the TD1508 device provides a standard Hayes “AT” command set used to control the module using ASCII readable commands and get answers, as well as to send or receive data.

The list of available commands with their corresponding arguments and return values, a description of their operation and some examples are detailed into the “*TD1508 Reference Manual*”.

### 3.2 USART (Universal Synchronous/Asynchronous Receiver/Transmitter)

The TD1508 provides an interface to an integrated USART capable of both asynchronous (UART and SmartCard) or synchronous (SPI and I2S) communications. All modes benefit from 2-level buffers with additional separate shift registers, configurable number of data bits and programmable bit endianness and baudrate.

Asynchronous mode allows both full and half-duplex operation with parity check/generation, parity and framing error detection and Break condition detection. Synchronous mode is capable of acting as an SPI master or slave, supporting all 4 SPI clock polarity/phase configurations.

The USART is available on pins USR1, USR2, USR3 and USR4. When not used for timer/counter operation, these pins can be configured to perform other functions using “AT” configuration commands, please refer to the “*TD1508 Reference Manual*” for details.

### 3.3 I<sup>2</sup>C bus

As a convenience, the TD1508 module is equipped with a popular I<sup>2</sup>C serial bus controller that enables communication with a number of external devices using only two I/O pins: SCL and SDA (alternatively, the DB2 and DB3 pins can be configured as SCL and SDA, respectively). The SCL pin is used to interface with the I<sup>2</sup>C clock signal, and the SDA pin to the I<sup>2</sup>C data signal, respectively. When not used for I<sup>2</sup>C bus, these 2 pins can be configured to perform other functions using “AT” configuration commands, please refer to the “*TD1508 Reference Manual*” for details.

The TD1508 module is capable of acting as both a master and a slave, and supports multi-master buses. Both standard-mode (Sm), fast-mode (Fm) and fast-mode plus (Fm+) speeds are supported, allowing transmission rates all the way from 10 kbit/s up to 1 Mbit/s. Slave arbitration and timeouts are also provided to allow implementation

of an SMBus compliant system. Both 7-bit and 10-bit addresses are supported, along with extensive error handling capabilities (clock low/high timeouts, arbitration lost, bus error detection).

The operation of this interface is controlled by the mean of Hayes “AT” commands sent over the UART interface. To obtain a list of the available commands with their corresponding arguments and return values, a description of their operation and some examples, please refer to the “*TD1508 Reference Manual*”.

### 3.4 Timer/Counter

The TD1508 provides an interface to an integrated low-power timer/counter using the TIM2 pin. This pin can be configured as either a capture input or a compare/PWM output to the 16-bit internal timer/counter. When not used for timer/counter operation, this pin can be configured to perform other functions using “AT” configuration commands, please refer to the “*TD1508 Reference Manual*” for details.

The low-power timer consists in a counter that can be configured to up-count, down-count, up/down-count (continuous or one-shot).

The low-power timer also contains 2 output channels, that can be configured as either an output compare or single/double slope PWM (Pulse-Width Modulation) outputs routed to the TIM2 pin.

The operation of this interface is controlled by the mean of Hayes “AT” commands sent over the UART interface. To obtain a list of the available commands with their corresponding arguments and return values, a description of their operation and some examples, please refer to the “*TD1508 Reference Manual*”.

### 3.5 ADC (Analog to Digital Converter)

The TD1508 provides an interface to an integrated low-power SAR (Successive Approximation Register) ADC, capable of a resolution of up to 12 bits at up to 1 Msps or 6 bits at up to 1.86 Msps. The ADC0 pin provides the external interface to the ADC. When not used for ADC operation, this pin can be configured to perform other functions using “AT” configuration commands, please refer to the “*TD1508 Reference Manual*” for details.

Along with the ADC0 analog input channel, the ADC also provides an internal temperature, VDD, and GND input channel that may be used to get a digital representation of analog temperature or voltage values. It is also possible to loopback the analog output of the integrated DAC (see section 3.6, “DAC (Digital to Analog Converter)”).

The internal ADC provides an optional input filter consisting of an internal low-pass RC filter or simple internal decoupling capacitor. The resistance and capacitance values are given in the electrical characteristics for the device, named  $R_{ADC\text{FILT}}$  and  $C_{ADC\text{FILT}}$  respectively.

The reference voltage used by the ADC can be selected from several sources, including a 1.25 V internal bandgap, a 2.5 V internal bandgap,  $V_{DD}$ , a 5 V internal differential bandgap or unbuffered  $2V_{DD}$ .

Additionally, to achieve higher accuracy, hardware oversampling can be enabled. With oversampling, each selected input is sampled a number of times, and the results are filtered by a first order accumulate and dump filter to form the end result. Using 16x oversampling minimum, it is thus possible to achieve result resolution of up to 16 bits.

The operation of this interface is controlled by the mean of Hayes “AT” commands sent over the UART interface. To obtain a list of the available commands with their corresponding arguments and return values, a description of their operation and some examples, please refer to the “*TD1508 Reference Manual*”.

### 3.6 DAC (Digital to Analog Converter)

The TD1508 provides an interface to an integrated DAC that can convert a digital value to a fully rail-to-rail analog output voltage with 12-bit resolution at up to 500 ksps. The DAC may be used for a number of different applications such as sensor interfaces or sound output. The analog DAC output is routed to the DAC0 pin. When not used for ADC operation, this pin can be configured to perform other functions using “AT” configuration commands, please refer to the “*TD1508 Reference Manual*” for details.

# TD1508

---

The reference voltage used by the DAC can be selected from several sources, including a 1.25 V internal bandgap, a 2.5 V internal bandgap, or  $V_{DD}$ .

The internal DAC provides support for offset and gain calibration, and contains an automatic sine generation mode as well as a loopback output to the ADC (see section 3.5, “ADC (Analog to Digital Converter)”).

## 3.7 GPIO (General Purpose Input/Output)

Apart from the TX and RX UART pins, and the RF pins, all signal pins are available as general-purpose inputs/outputs. This includes of course the generic USR0, USR1, USR2, US3 and USR4 pins, but also the ADC0, TIM2, DAC0, SCL, SDA, DB2, DB3 pins when not used for their main function. This configuration can be performed using “AT” commands, please refer to the “TD1508 Reference Manual” for details.

All the USR0, USR1, USR2, USR3, USR4, ADC0, TIM2, DAC0, SCL, SDA, DB2, DB3 pins can be configured individually as tristate (default reset state), push-pull, open-drain, with/without pull-up or pull-down resistor, and with a programmable drive strength (0.5 mA/2 mA/6 mA/20 mA).

When configured as inputs, these pins feature an optional glitch suppression filter and full (rising, falling or both edges) interrupt with wake-up from low-power mode capabilities. Of course, the pin configuration is retained even when using these low-power modes.

The operation of the GPIOs is controlled by the mean of Hayes “AT” commands sent over the UART interface. To obtain a list of the available commands with their corresponding arguments and return values, a description of their operation and some examples, please refer to the “TD1508 Reference Manual”.

## 3.8 RST (Reset)

The TD1508 module features an active-low RST pin. This pin is held high by an internal pull-up resistor, so when not used, this pin can be left floating.

## 3.9 Debug

The TD1508 module devices include hardware debug support through a 2-pin serial-wire debug interface. The 2 pins DB2 and DB3 are used for this purpose. The DB2 pin is the ARM Cortex-M3’s SWDIO Serial Wire data Input/Output. This pin is enabled after a reset and has a built in pull-up. The DB3 pin is the ARM Cortex-M3’s SWCLK Serial Wire Clock input. This pin is enabled after reset and has a built-in pull down. When not used for debug operation, these 2 pins can be configured to perform other functions using “AT” configuration commands, please refer to the “TD1508 Reference Manual” for details.

Additionally, the USR0, USR1 or USR2 pins can be used as the ARM Cortex-M3’s SWO Serial Wire viewer Output. Note that this function is not enabled after reset, and must be enabled by software to be used.

Although the ARM Cortex-M3 supports advanced debugging features, the TD1508 devices only use two port pins for debugging or programming. The systems internal and external state can be examined with debug extensions supporting instruction or data access break- and watch points.

For more information on how to enable the debug pin outputs/inputs the reader is referred to Section 28.3.4.1 (p. 457), the ARM Cortex-M3 Technical Reference Manual and the ARM CoreSight™ Technical Reference Manual.

## 3.10 RF Antenna

The TD1508 support a single-ended RF pin with 50  $\Omega$  characteristic impedance for connecting a matched-impedance external antenna. This pin is physically surrounded by 2 RF\_GND pins for better noise immunity.

## 3.11 VDD & GND

The TD1508 provides 5 GND pins and 2 RF\_GND pins: all of them must be connected to a good ground plane.

A 10  $\mu$ F/6.3 V decoupling capacitor should be placed as closed as possible to the single VDD pin.

---

## **4 Bootloader**

The TD1508 module contains an integrated bootloader which allows reflashing the module firmware either over the RX/TX UART connection, or over the air using the built-in RF transceiver.

The bootloader is automatically activated upon module reset. Once activated, the bootloader will monitor the UART/RF activity for a 200 ms period, and detect an incoming update condition.

If the update condition is met, the TD1508 will automatically proceed to flash the new firmware with safe retry mechanisms, or falls back to normal operation.

## 5 Pin Descriptions

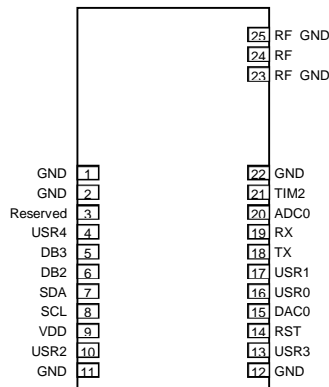

Pin	Pin Name	I/O	Description
1	GND	GND	<b>Connect to PCB ground</b>
2	GND	GND	<b>Connect to PCB ground</b>
3	Reserved	I/O	<b>Reserved pin – Do not connect</b>
4	USR4	I/O	<b>General Purpose Low-Power Digital I/O</b> This pin may be configured to perform various functions.
5	DB3	I	<b>SWDCLK (SWD Clock) Signal</b> This signal provides the SWD clock signal to the integrated TD1508 ARM® CPU. This pin may be configured to perform various functions.
6	DB2	I/O	<b>SWDIO (SWD Data I/O) Signal</b> This signal provides the SWD programming/debugging signal interface to the integrated TD1508 ARM® CPU. This pin may be configured to perform various functions.
7	SDA	I/O	<b>General Purpose Low-Power Digital I/O</b> This pin may be configured to perform various functions, including the I <sup>2</sup> C DATA (SDA) function.
8	SCL	I/O	<b>General Purpose Low-Power Digital I/O</b> This pin may be configured to perform various functions, including the I <sup>2</sup> C clock (SCL) function.
9	VDD	VDD	<b>+2.3 to +3.3 V Supply Voltage Input</b> The recommended VDD supply voltage is +3.0V. Connect a 10 µF capacitor as close as possible to this input.
10	USR2	I/O	<b>General Purpose Low-Power Digital I/O</b> This pin may be configured to perform various functions.
11	GND	GND	<b>Connect to PCB ground</b>
12	GND	GND	<b>Connect to PCB ground</b>
13	USR3	I/O	<b>General Purpose Low-Power Digital I/O</b> This pin may be configured to perform various functions.
14	RST	I	<b>Active Low RESET input signal</b> This signal resets the TD1508 module to its initial state. If not used, this signal can be left floating, as it is internally pulled up by an integrated resistor.
15	DAC0	I/O	<b>General Purpose Low-Power Digital I/O</b> This pin may be configured to perform various functions, including the DAC analog output #0 function.
16	USR0	I/O	<b>General Purpose Low-Power Digital I/O</b> This pin may be configured to perform various functions.
17	USR1	I/O	<b>General Purpose Low-Power Digital I/O</b>

			This pin may be configured to perform various functions.
18	TX	O	<b>Low-Power UART Data Transmit Signal</b> This signal provides the UART data going from the TD1508 module out to the host application processor. This signal is internally pulled up by an integrated resistor.
19	RX	I	<b>Low-Power UART Data Receive Signal</b> This signal provides the UART data coming from the host application processor going to the TD1508 module. This signal is internally pulled up by an integrated resistor.
20	ADC0	I/O	<b>General Purpose Low-Power Digital I/O</b> This pin may be configured to perform various functions, including the ADC input #6 function.
21	TIM2	I/O	<b>General Purpose Low-Power Digital I/O</b> This pin may be configured to perform various functions, including the timer input capture / output compare #2 function.
22	GND	GND	<b>Connect to PCB ground</b>
23	RF_GND	GND	<b>Connect to PCB ground</b>
24	RF	RF	<b>50 <math>\Omega</math> Antenna Connection</b>
25	RF_GND	GND	<b>Connect to PCB ground</b>

## 6 I/O alternate functionalities

Pin Name	Location		Description
	Port	Bit	
TX	C	6	LEUART0 TX function. Analog Comparator ACMP0, channel 6. I <sup>2</sup> C bus 1 DATA (SDA) function. LESENSE Channel 6.
RX	C	7	LEUART0 RX function. Analog Comparator ACMP0, channel 7. I <sup>2</sup> C bus 1 CLOCK (SCL) function. LESENSE Channel 7.
DAC0	C	12	Digital to Analog Converter DAC0 output. Analog comparator ACMP1, channel 4. Operational Amplifier 1 alternate output. UART 1 TX function.
USR0	C	15	Analog Comparator ACMP1, channel 7. Digital to Analog Converter DAC0 alternate output. Operational Amplifier 1 alternate output. Timer 1 Capture Compare input / output channel 2. UART 0 RX function. LESENSE Channel 15. Debug-interface Serial Wire viewer output. Note that this function is not enabled after reset, and must be enabled by software to be used
USR4	D	0	Analog to digital converter ADC0, input channel number 0. Operational Amplifier 2 output. Pulse Counter 2, input 0. USART1 TX (MOSI) function.
USR2	D	1	Analog to digital converter ADC0, input channel number 1. Digital to Analog Converter DAC0 alternate output. Operational Amplifier 1 alternate output. Timer 0, input/output 0. Pulse Counter 2, input 1. USART1 RX (MISO) function. Debug-interface Serial Wire viewer output. Note that this function is not enabled after reset, and must be enabled by software to be used
USR1	D	2	Analog to digital converter ADC0, input channel number 2. Timer 0, input/output 1. USART1 Clock (CLK) function. Debug-interface Serial Wire viewer output. Note that this function is not enabled after reset, and must be enabled by software to be used
USR3	D	3	Analog to digital converter ADC0, input channel number 3. Timer 0, input/output 2. USART1 Chip Select (CS) function. Debug-interface Serial Wire viewer output. Note that this function is not enabled after reset, and must be enabled by software to be used
ADC0	D	6	Analog to digital converter ADC0, input channel number 6. Operational Amplifier 1 positive input. Timer 1, input/output 0. LETIMER0, output 0. Pulse Counter 0, input 0. USART1 RX function. I <sup>2</sup> C bus 0 DATA (SDA) function. LESENSE Alternate Excite Channel 0. Analog Comparator ACMP0 output.



TIM2	D	7	<p>LETIMER0, output 1.  Analog to digital converter ADC0, input channel number 7.  Operational Amplifier 1 negative input.  Timer 1, input/output 1.  Pulse Counter 0, input 1.  USART1 TX function.  I<sup>2</sup>C bus 0 CLOCK (SCL) function.  CMU Clock output number 0.  LESENSE Alternate Excite Channel 1.  Analog Comparator ACMP1 output.</p>
SDA	E	0	<p>I<sup>2</sup>C bus 0 DATA (SDA) function.  Timer 3, input/output 0.  Pulse Counter 0, input 0.</p>
SCL	E	1	<p>I<sup>2</sup>C bus 0 CLOCK (SCL) function.  Timer 3, input/output 1.  Pulse Counter 0, input 1.</p>
DB3	F	0	<p><b>Debug-interface Serial Wire clock input.</b>  Note that this function is enabled to pin out of reset, and has a built-in pull-down  Timer 0, input/output 0.  LETIMER0 output number 0.  USART1 Clock (CLK) function.  LEUART0 TX function.  I<sup>2</sup>C bus 0 DATA (SDA) function.</p>
DB2	F	1	<p><b>Debug-interface Serial Wire data input / output.</b>  Note that this function is enabled to pin out of reset, and has a built-in pull up  Timer 0, input/output 1.  LETIMER0 output number 1.  USART1 Chip Select (CS) function.  LEUART0 RX function.  I<sup>2</sup>C bus 0 CLOCK (SCL) function.  Wake-up from EM4, pin number 3.</p>

# TD1508

## 7 Ordering Information

---

Part Number	Description	Package Type	Operating Temperature
TD1508-US	US ISM SIGFOX™ gateway 128K Flash/32KRAM TCXO	LGA25 Pb-free	-30° to +75°C

The TD1508-US ISM SIGFOX™ gateway module is available in several conditionings.

Please contact Telecom Design for more information.

## 8 Package Outline

Figure 2 illustrates the package details for the TD1508.

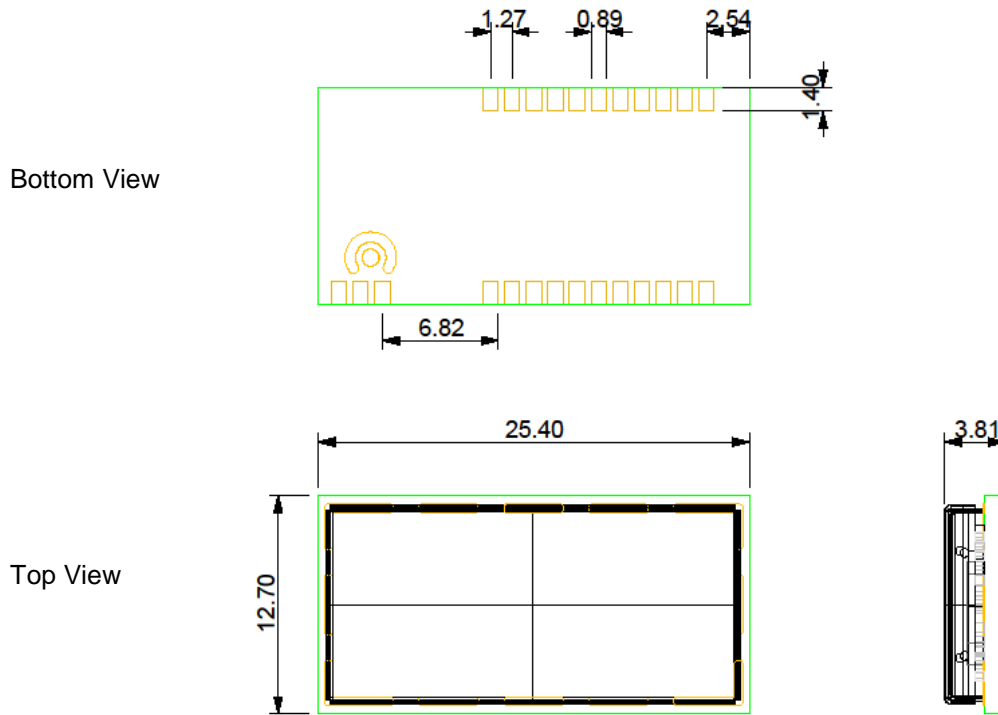

Figure 2. 25-Pin Land Grid Array (LGA)

**Notes:**

1. All dimensions are shown in millimeters (mm) unless otherwise noted.

# TD1508

## 9 PCB Land Pattern

Figure 3 illustrates the PB land pattern details for the TD1508.

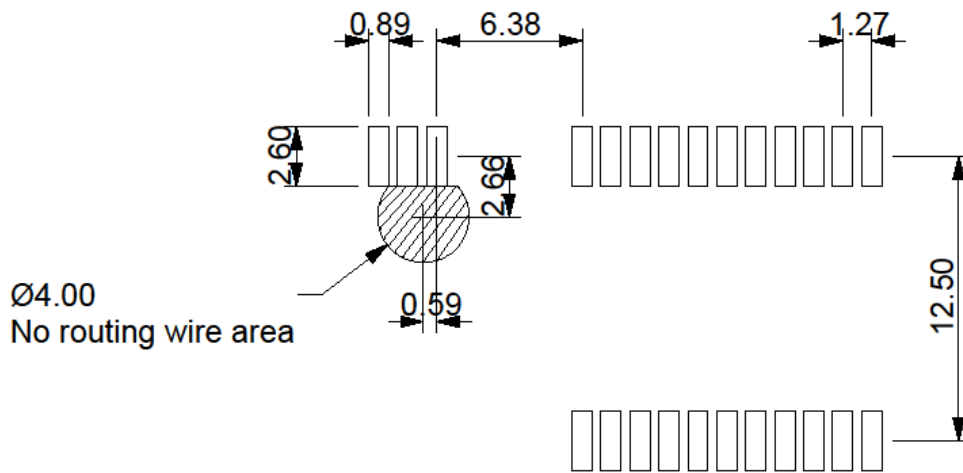

Figure 3. PCB Land Pattern

### Notes:

1. All dimensions are shown in millimeters (mm) unless otherwise noted.

## 10 Soldering Information

### 10.1 Solder Stencil

The TD1508 module is designed for RoHS reflow process surface mounting.

For proper module assembly, the solder paste must be applied on the receiving PCB using a metallic stencil with a recommended 0.150 μm thickness.

### 10.2 Reflow soldering profile

The recommendation for lead-free solder reflow from IPC/JEDEC J-STD-020D Standard should be followed.

Below are typical reflow soldering profiles for a medium-size board:

Setpoints	1	2	3	4	5	6	7	8	9
Top (°C)	145	155	165	175	185	195	230	250	250
Bottom (°C)	145	155	165	175	185	195	230	250	250

**Notes:** Conveyor Speed is 65.00 cm / min

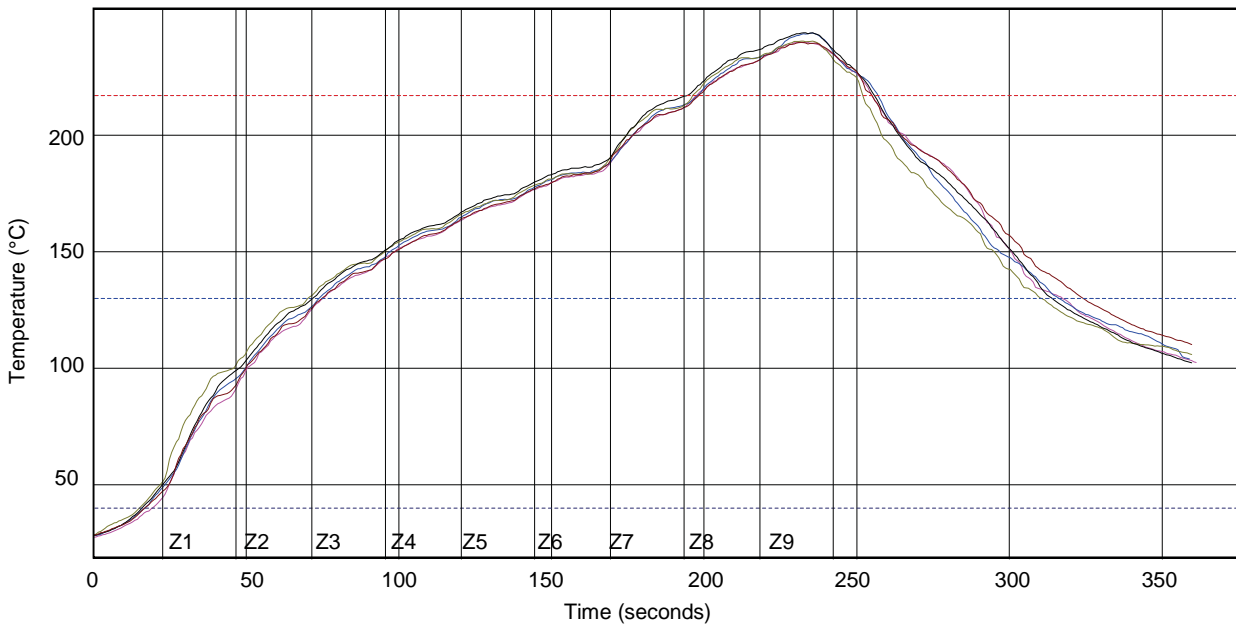

Figure 4 - Reflow Soldering Profile

Run	Preheat (s) 40-130°C	Soak Time (s) 130-217°C	Reflow Time (s) / 217°C	Peak Temp (°C)	Max. Slope1 (°C / s) (40-130°C)	Max. Slope2 (°C / s) (250-150°C)
2	56.04	122.40	58.66	239.00	1.53	-2.78
3	56.93	123.72	59.45	243.93	1.56	-2.79
4	55.34	124.25	57.34	239.45	1.54	-2.87
5	55.92	122.53	61.46	244.00	1.57	-2.77
6	58.12	123.38	57.89	239.84	1.53	-2.73

For more information on reflow soldering process profiling, please visit the <http://kicthermal.com/> website.

# TD1508

## 11 Board Mounting Recommendation

### 11.1 Electrical Environment

The best TD1508 module performances are obtained in a “noise free” environment. Some basic recommendations must be followed:

- Noisy electronic components (serial RS232, DC/DC Converter, Display, Ram, bus...) must be placed as far as possible from the TD1508 module.

**CAUTION – A particular attention must be put on switching power supply DC/DC converter, due to switching frequency that generates spurious into the receiver band, as it can strongly decrease module performances. Therefore it is recommended to put a metallic shield covering the DC/DC conversion function.**

- Switching component circuits (especially RS-232/TTL interface circuit power supply) must be decoupled with a 100  $\mu\text{F}$  low ESR tantalum capacitor. The decoupling capacitor must be placed as close as possible to the noisy chip.

### 11.2 Power Supply Decoupling

The power supply of the TD1508 module must be closely decoupled. An LC filter is strongly recommended in case of a switching DC/DC power supply converter. It must be placed as close as possible to the TD1508 module power supply pin VDD.

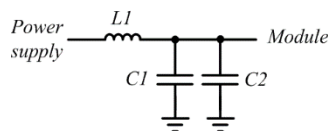

Figure 5- Power supply decoupling

For example:

Symbol	Reference	Value	Manufacturer
L1	LQH32CN1R0M33	1 $\mu\text{H}$	Murata
C1	GRM31CF51A226ZE01	22 $\mu\text{F}$	Murata
C2	Ceramic CMS 25V	100 nF	Multiple

### 11.3 RF Layout Considerations

Basic recommendations must be followed to achieve a good RF layout:

- It is recommended to fill all unused PCB area around the module with ground plane
- The radio module ground pins must be connected to a solid ground plane
- If the ground plane is on the bottom side, a via (metal hole) must be used in front of each ground pad. Especially pins 23 and 25 (RF\_GND) pins should be grounded via several holes to be located right next to the pins, thus minimizing inductance and preventing mismatch and losses

### 11.4 Host Antenna Circuit Trace Design

#### 11.4.1 Filter and Matching

This block has 2 purposes:

- Filter the RF signal, especially harmonic 2 (H2) in transmit mode
- Match antenna impedance to 50  $\Omega$

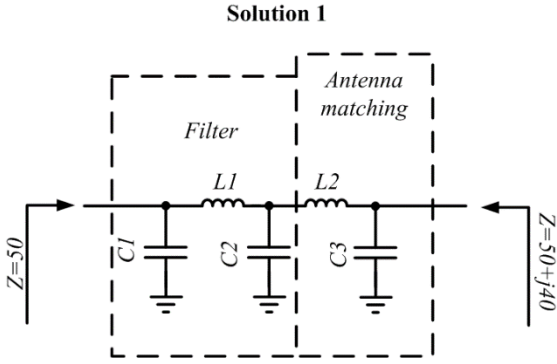

Figure 6 - Classic filter architecture

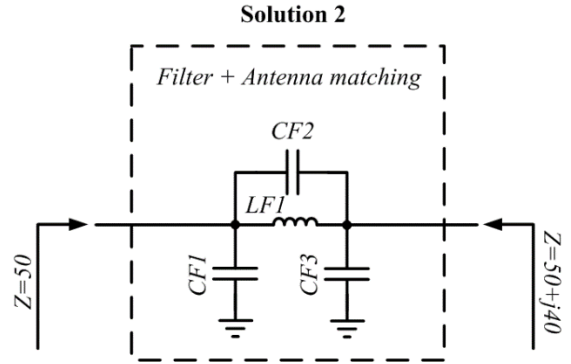
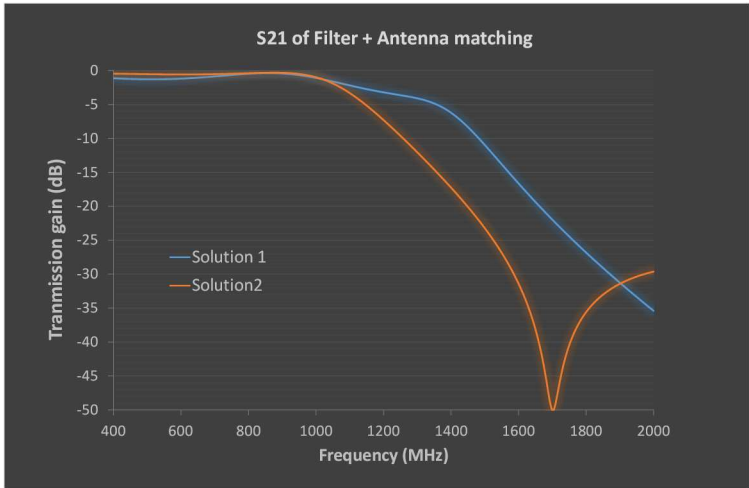

Figure 7 - Proposed filter architecture

The proposed filter network is designed in order to match and filter with optimal performances while requiring the minimum number of passive components (Figure 7).

For an example antenna featuring a  $(50+j*40) \Omega$  impedance that must be filtered and matched to the  $50 \Omega$  TD1508 module impedance, the tables and graphics below summarize the component values used in order to present a  $(50-j*40)\Omega$  impedance at antenna connection with a good H2 rejection and the corresponding transmission gains:

Component	C1	L1	C2	L2	C3	CF1	CF2	LF1	CF3
Value	4.7pF	9.1nH	4.7pF	8.2nH	3.3pF	3pF	1pF	8.2nH	4.7pF



S21 (dB)	Solution 1	Solution 2
@ 868MHz	-0.37	-0.32
@1736MHz	-23.7	-42.8

11.4.2 RF Reference Layout

In order to get the best performance while meeting the electromagnetic interference standard requirements, the RF trace geometric characteristics and passive component placement must be controlled, such that the RF signal traces are surrounded by a solid ground plane and the RF signal traces matched to the  $50 \Omega$  impedance.

The 2 most common trace topologies used are the Microstrip and Coplanar Waveguide with lower ground configurations, which are illustrated in figures 8 and 9 below:

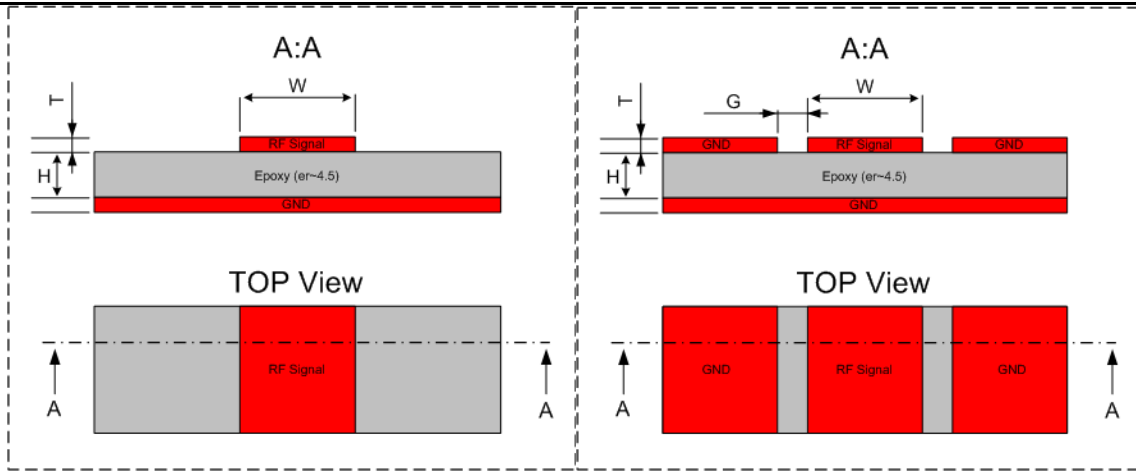

**Figure 8- Microstrip Line (MS)**

**Figure 9 Lower Ground Waveguide (CPWG)**

The table below provides the recommended trace width to obtain 50 Ω impedance for RF traces on an PCB stack up (Prepreg) having an  $\epsilon_r = 4.5$ . For the CPWG solution, the proposed clearance between the RF signal and ground is chosen to be 0.21 mm.

H (μm)	MS	CPWG (G=0.21mm)
	W (mm)	W (mm)
150	0.254	0.254
250	0.43	0.38
350	0.6	0.5
450	0.81	0.59
550	1	0.67
1200	2.21	0.98
1600	2.97	1.07

Figure 10 provides more details on the required trace width relative to the Epoxy thickness (H):

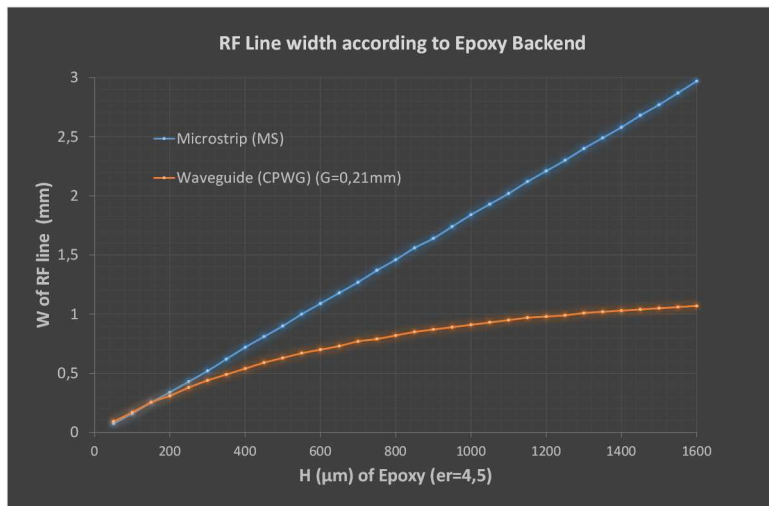

**Figure 10- RF trace width relative to Epoxy stackup thickness**

As can be observed, the MS trace width is wider and more dependent on H than the CPWG trace width:

However, because of the increasing demand to downscale circuits, the MS solution allows to increase the component and trace density, see Figure 11 below:



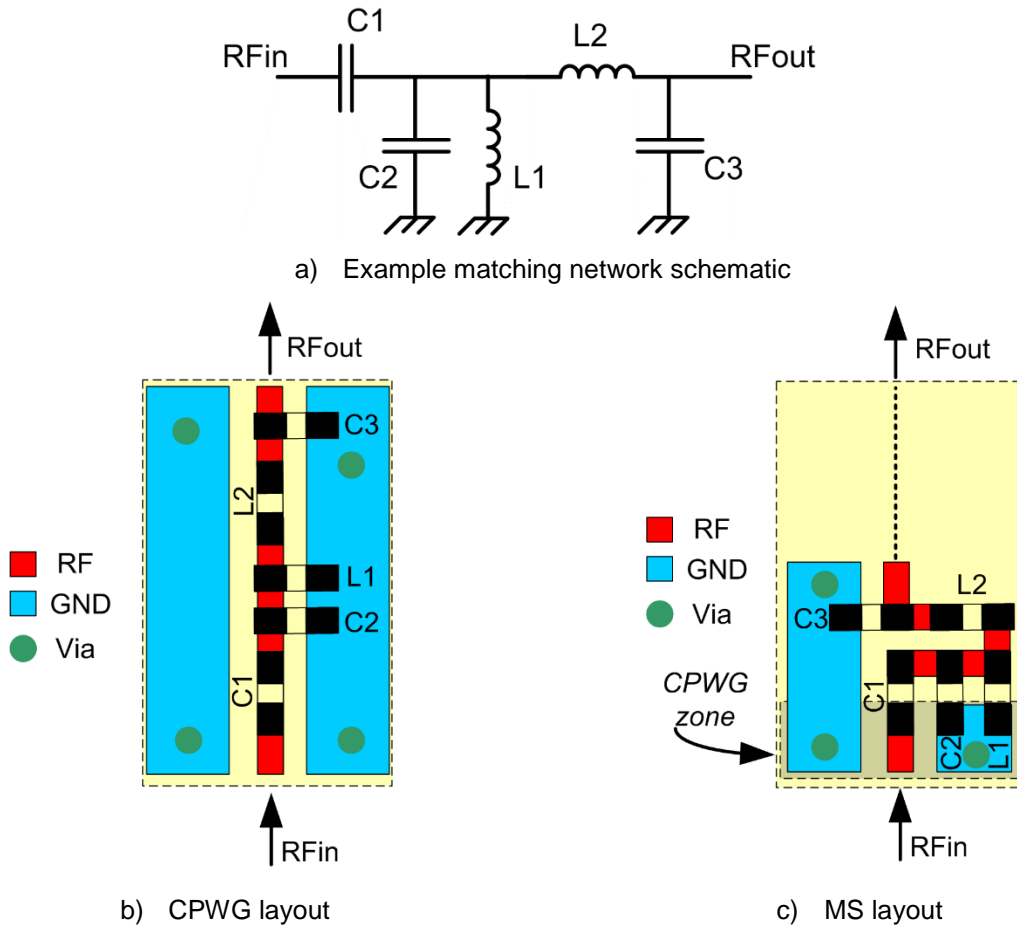

Figure 11- Impact of RF trace topology choice on board real-estate

Nevertheless, several RF matching network components must be connected to GND, creating a parasitic CPWG area in the MS configuration (e.g. gray area in MS layout). In order to limit the influence of this area, H must be kept thin (< 400µm), such that the width of MS and CPWG traces are similar and achieve the same 50 Ω impedance (cf. Figure 10). It is also possible to update the RF signal to GND clearance value (G) for CPWG in order to get the same impedance with the same trace width between MS and CPWG configurations.

The quality of the ground plane is essential for a good RF performance. Several vias must be placed in order to connect together (“stitch”) the grounds (top layer and internal layer) and to avoid a parasitic antenna phenomenon or voltage level differences over the overall circuit ground. However, too numerous via holes may weaken the FR4 mechanical properties, so there should not be too many of them in order to avoid any side effects and decrease the circuit reliability.

# TD1508

## 11.4.3 Proposed PCB Stack-Up for combined MS / CPWG RF Traces

The proposed PCB stack-up is depicted in Figure 12. This stack-up is made up of 4 copper layers with a total thickness of about 1.6 mm. The core FR4 thickness can be modified in order to reach a total thickness of 1.2 mm.

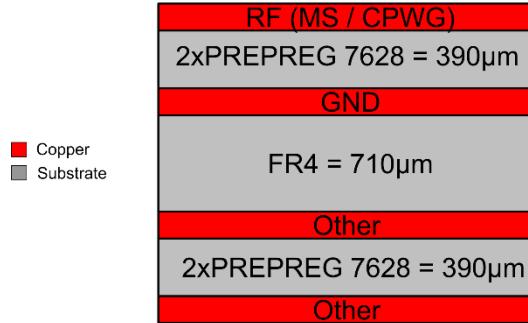

**Figure 12- Proposed PCB stack-up**

The width (W) of RF traces is fixed to 0.6 mm (matching 0402 component footprints), with a clearance (G) of 0.35 mm. These values allow to cancel the 0402 footprint impact on the RF matching. The table below provides the expected minimum and maximum RF trace impedances relative to the PREPREG tolerances:

2xPREPREG 7628	Impedance of MS ( $\Omega$ )	Impedance of CPWG ( $\Omega$ )
(-40 $\mu\text{m}$ ) => 350 $\mu\text{m}$	51.3	48.9
(+0 $\mu\text{m}$ ) => 390 $\mu\text{m}$	54.6	51.3
(+40 $\mu\text{m}$ ) => 430 $\mu\text{m}$	57.6	53.3

## 12 Conformity Assessment Issues / FCC Regulatory Notices

### 12.1 Modification Statement

Telecom Design S.A. does not approve any changes or modifications to this device by the user. Any changes or modifications could void the user's authority to operate the equipment.

### 12.2 Interference Statement

This device complies with Part 15 of the FCC Rules.

Operation is subject to the following two conditions:

- (1) This device may not cause harmful interference, and
- (2) This device must accept any interference received, including interference that may cause undesired operation.

### 12.3 Wireless Notice

This equipment complies with FCC radiation exposure limits set forth for an uncontrolled environment. This equipment should be installed and operated with a minimum distance of 20 cm between the radiator and your body.

Antenna gain and type must be:

Type	Maximum Gain
$\lambda/2$ dipole antenna	2 dBi

This transmitter must not be co-located or operating in conjunction with any other antenna or transmitter.

### 12.4 FCC Class B Digital Device Notice

This equipment has been tested and found to comply with the limits for a Class B digital device, pursuant to Part 15 of the FCC Rules. These limits are designed to provide reasonable protection against harmful interference in a residential installation. This equipment generates, uses and can radiate radio frequency energy and, if not installed and used in accordance with the instructions, may cause harmful interference to radio communications. However, there is no guarantee that interference will not occur in a particular installation. If this equipment does cause harmful interference to radio or television reception, which can be determined by turning the equipment off and on, the user is encouraged to try to correct the interference by one or more of the following measures:

- Reorient or relocate the receiving antenna.
- Increase the separation between the equipment and receiver.
- Connect the equipment into an outlet on a circuit different from that to which the receiver is connected.

Consult the dealer or an experienced radio/TV technician for help.

### 12.5 Labelling Requirements for the Host Device

The host device shall be properly labelled to identify the modules within the host device. The certification label of the module shall be clearly visible at all times when installed in the host device, otherwise the host device must be labelled to display the FCC ID of the module, preceded by the words "Contains transmitter module", or the word "Contains", or similar wording expressing the same meaning, as follows:

Contains FCC ID: 2AGMK-TD1508

# TD1508

---

## DOCUMENT CHANGE LIST

### Revision 1.0

- First Release

### Revision 1.1

- Remove the 25dBm output configuration
- Change TX power consumption

### Revision 1.2

- Added FCC and IC warning statements

### Revision 1.3

- Removed IC warning statements
- Added Board Mounting Recommendation
- Added Conformity Assessment Issues / FCC Regulatory Notices

### Revision 1.4

- Corrected minimal distance unit

---

NOTES:

# TD1508

---

## CONTACT INFORMATION

### Telecom Design S.A.

Zone Actipolis II — 2 bis rue Nully de Harcourt  
33610 CANEJAN, France  
Tel: +33 5 57 35 63 70  
Fax: +33 5 57 35 63 71

Please visit the Telecom Design web page:

<http://www.telecomdesign.fr/>

The information in this document is believed to be accurate in all respects at the time of publication but is subject to change without notice. Telecom Design assumes no responsibility for errors and omissions, and disclaims responsibility for any consequences resulting from the use of information included herein. Additionally, Telecom Design assumes no responsibility for the functioning of undescribed features or parameters. Telecom Design reserves the right to make changes without further notice. Telecom Design makes no warranty, representation or guarantee regarding the suitability of its products for any particular purpose, nor does Telecom Design assume any liability arising out of the application or use of any product or circuit, and specifically disclaims any and all liability, including without limitation consequential or incidental damages. Telecom Design products are not designed, intended, or authorized for use in applications intended to support or sustain life, or for any other application in which the failure of the Telecom Design product could create a situation where personal injury or death may occur. Should Buyer purchase or use Telecom Design products for any such unintended or unauthorized application, Buyer shall indemnify and hold Telecom Design harmless against all claims and damages.

Telecom Design is a trademark of Telecom Design S.A.

SIGFOX™ is a trademark of SigFox S.A.

Other products or brand names mentioned herein are trademarks or registered trademarks of their respective holders.