

General Description

The TD1662 is a 60V, 3A SIMPLE SWITCHER step down regulator with an integrated high-side MOSFET. With a wide input range from 9V to 60V, it's suitable for various applications from industrial to automotive for power conditioning from unregulated sources. An ultra-low 1 μ A current in shutdown mode can further prolong battery life. Internal loop compensation means that the user is free from the tedious task of loop compensation design. This also minimizes the external components of the device. A precision enable input allows simplification of regulator control and system power sequencing. The device also has built-in protection features such as cycle-by-cycle current limit, thermal sensing and shutdown due to excessive power dissipation, and output overvoltage protection.

The TD1662 is available in a ESOP-8 package.

Features

- 9V to 60V Input Range
- 3 A Continuous Output Current
- 150 m Ω High-Side MOSFET
- Current Mode Control
- Adjustable Switching Frequency from 200kHz to 1 MHz
- Internal Compensation for Ease of Use
- 1 μ A Shutdown Current
- Thermal, Overvoltage and Short Protection
- Available in a ESOP-8 Package

Applications

- Automotive Battery Regulation
- Industrial Power Supplies
- Telecom and Datacom Systems
- General Purpose Wide Vin Regulation

Pin Configurations

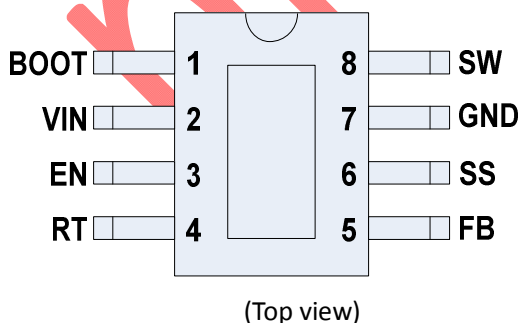

Pin Description

Pin Number	Pin Name	Description
1	BOOT	Bootstrap capacitor connection for high-side MOSFET driver. Connect a high quality 0.1μF capacitor from BOOT to SW.
2	VIN	Connect to power supply and bypass capacitors C _{IN} . Path from VIN pin to high frequency bypass C _{IN} and GND must be as short as possible.
3	EN	Enable pin, with internal pull-up current source. Pull below 1.2V to disable. Float or connect to VIN to enable. Adjust the input under voltage lockout with two resistors. See the Enable and Adjusting Under voltage lockout section.
4	RT	Resistor Timing. An internal amplifier holds this pin at a fixed voltage when using an external resistor to ground to set the switching frequency.
5	FB	Feedback input pin, connect to the feedback divider to set V _{OUT} . Do not short this pin to ground during operation.
6	SS	SS pin for soft-start version, connect to a capacitor to set soft-start time.
7	GND	System ground pin.
8	SW	Switching output of the regulator. Internally connected to high-side power MOSFET. Connect to power inductor.
9	Thermal Pad	Major heat dissipation path of the die. Must be connected to ground plane on PCB.

Ordering Information

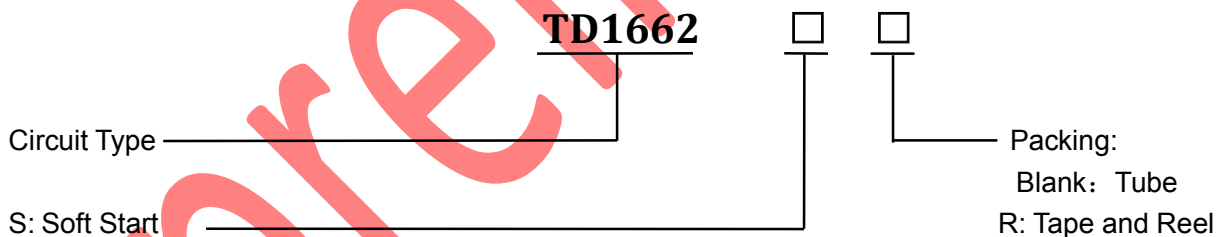

Function Block

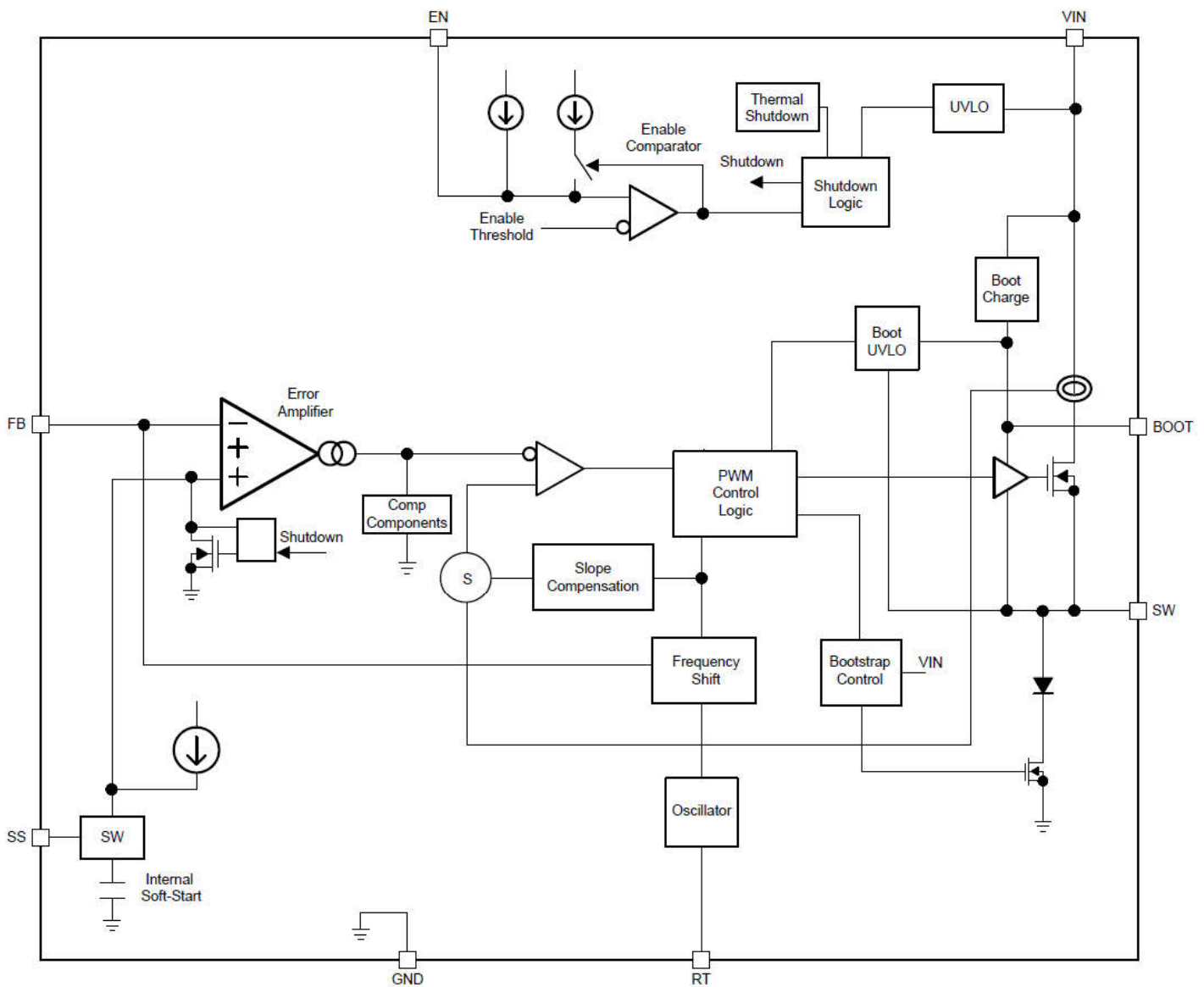

Figure1 Function Block Diagram of TD1662

Absolute Maximum Ratings (Note1)

		Rating	Unit
Input Voltages	VIN to GND	-0.3 to 60	V
	EN to GND	-0.3 to 5	
	SS to GND	-0.3 to 5	
	FB to GND	-0.3 to 7	

60V, 3A, Step-Down Converter

TD1662

Output Voltages	BOOT to SW	6.5	V
	SW to GND	-0.3 to VIN+0.3	
T _J	Junction Temperature	150	°C
T _{STG}	Storage Temperature	-65 ~ 150	°C
T _{SDR}	Maximum Lead Soldering Temperature (10 Seconds)	260	°C

Note1: Stresses beyond those listed under "absolute maximum ratings" may cause permanent damage to the device. These are stress ratings only and functional operation of the device at these or any other conditions beyond those indicated under "recommended operating conditions" is not implied. Exposure to absolute maximum rating conditions for extended periods may affect device reliability.

ESD Ratings

		VALUE	UNIT
V _(ESD) Electrostatic discharge	Human-boody model(HBM)	±2000	V

Recommended Operation Conditions

		Range	Unit
Buck Regulator	VIN	9 to 60	V
	VOOUT	0.8 to 50	
	SW	-1 to 60	
	FB	0 to 5	
Frequency	Switching frequency range	200 to 1000	kHz
Temperature	Operating junction temperature, T _J	-40 to 125	°C

Operating Ratings indicate conditions for which the device is intended to be functional, but do not guarantee specific performance limits.

For guaranteed specifications, see Electrical Characteristics .

60V, 3A, Step-Down Converter

TD1662

Electrical Characteristics

Limits apply over the recommended operating junction temperature (T_J) range of $-40\text{ }^{\circ}\text{C}$ to $+125\text{ }^{\circ}\text{C}$, unless otherwise stated.

Minimum and Maximum limits are specified through test, design or statistical correlation. Typical values represent the most likely parametric norm at $T_J = 25\text{ }^{\circ}\text{C}$, and are provided for reference purposes only. Unless otherwise specified, the following conditions apply: $V_{IN} = 9\text{ V}$ to 60 V .

Symbol	Parameter	Test Conditions	Min	Typ	Max	Unit
V_{IN}	Operation input voltage		9	-	60	V
UVLO	Under voltage lockout thresholds	Rising threshold	-	8.5	-	V
		Hysteresis	-	1.4	-	V
I_{SHDN}	Shutdown supply current	$V_{EN} = 0\text{V}$, $T_A = 25\text{ }^{\circ}\text{C}$, $9\text{V} \leq V_{IN} \leq 60\text{V}$	-	1.0	3.0	μA
I_Q	Operating quiescent current (non-switching)	$V_{FB} = 1.0\text{V}$, $T_A = 25\text{ }^{\circ}\text{C}$	-	200	-	μA
ENABLE (EN PIN)						
V_{EN_TH}	EN Threshold Voltage		-	2	-	V
SOFT-START						
I_{SS}	SS pin current	For External Soft-Start version only, $T_A = 25\text{ }^{\circ}\text{C}$	-	-3.0	-	μA
VOLTAGE REFERENCE (FB PIN)						
V_{FB}	Feedback voltage	$T_J = 25\text{ }^{\circ}\text{C}$	0.735	0.750	0.765	V
HIGH-SIDE MOSFET						
R_{DS_ON}	On-resistance	$V_{IN} = 12\text{ V}$, BOOT to SW = 5.8 V	-	150	-	m Ω
HIGH-SIDE MOSFET CURRENT LIMIT						
I_{LIMIT}	Current limit	$V_{IN} = 12\text{ V}$, $T_A = 25\text{ }^{\circ}\text{C}$, Open Loop	3.80	4.75	5.70	A
THERMAL PERFORMANCE						
T_{SHDN}	Thermal shutdown threshold		-	150	-	$^{\circ}\text{C}$
T_{HYS}	Hysteresis		-	12	-	

Switching Characteristics

Over the recommended operating junction temperature range of $-40\text{ }^{\circ}\text{C}$ to $125\text{ }^{\circ}\text{C}$ (unless otherwise noted)

Symbol	Parameter	Test Conditions	Min	Typ	Max	Unit
f_{SW}	Switching frequency	$R_T = 49.9\text{ k}\Omega$	400	500	600	kHz
T_{ON_MIN}	Minimum controllable on time	$V_{IN} = 12\text{ V}$, BOOT to SW = 5.8 V, $I_{Load} = 1\text{ A}$		160		ns
D_{MAX}	Maximum duty cycle	$f_{SW} = 500\text{ kHz}$		90%		

Typical Application Circuit

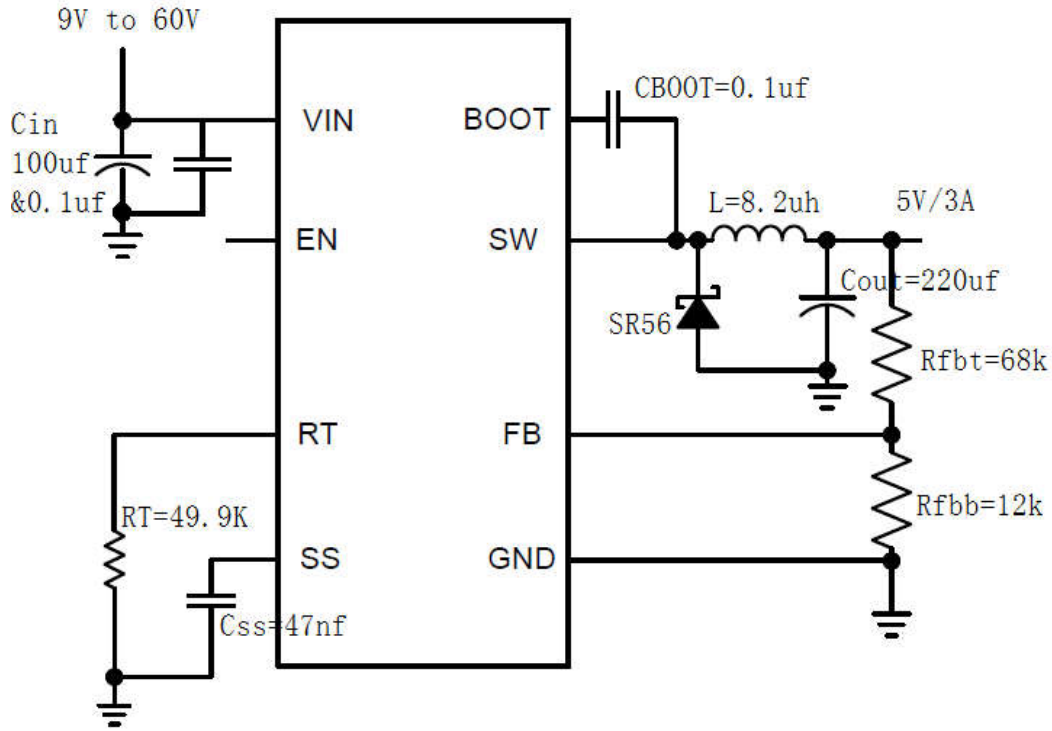
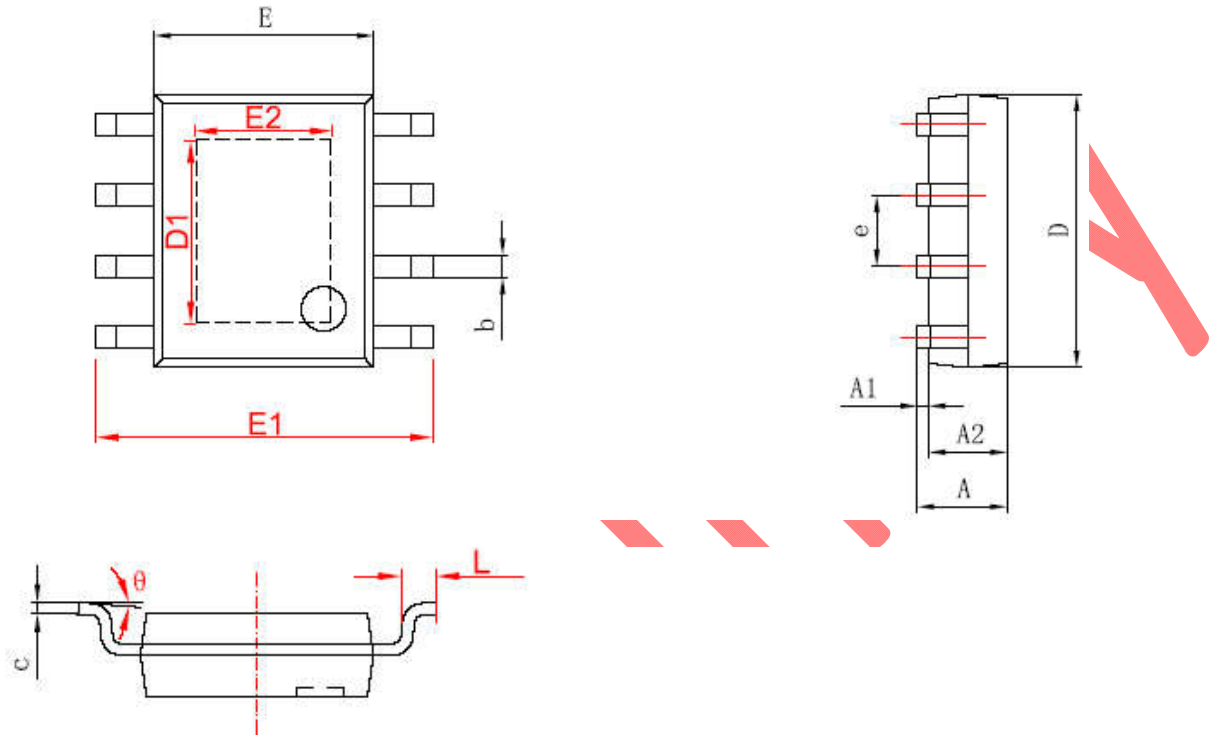

Figure2 Application Circuit, 5V Output

preliminary

Package Information

ESOP-8 Package Outline Dimensions



	Dimensions In Millimeters		Dimensions In Inches	
	Min	Max	Min	Max
A	1.350	1.750	0.053	0.069
A1	0.050	0.150	0.004	0.010
A2	1.350	1.550	0.053	0.061
b	0.330	0.510	0.013	0.020
c	0.170	0.250	0.006	0.010
D	4.700	5.100	0.185	0.200
D1	3.202	3.402	0.126	0.134
E	3.800	4.000	0.150	0.157
E1	5.800	6.200	0.228	0.244
E2	2.313	2.513	0.091	0.099
e	1.270 (BSC)		0.050 (BSC)	
L	0.400	1.270	0.016	0.050
theta	0°	8°	0°	8°

Design Notes

preliminary