

TOSHIBA BIPOLAR DIGITAL INTEGRATED CIRCUIT SILICON MONOLITHIC

# TD62650F, TD62651F, TD62652F

## 5V POWER SUPPLY & SUPPLY MONITORING + COMMUNICATIONS IC

The TD62650F series covers products developed for use in microcomputer systems applicable to automatic vending machines. They produce an output voltage of 5 V ± 0.5 V without need for adjustment, through their accurate reference voltage and amplifier circuit.

The 5V section can reset the system by outputting reset signals at power-on, and also output a reset signal when the 5 V output voltage drops below the specified 92% (TD62650F / 652F) or 85% (TD62651F) because of external disturbances or other problem. It also incorporates a watchdog timer for self-diagnosing the system. When the system malfunctions, the IC generates reset pulses intermittently to prevent the system from running away. The interface section incorporates three serial ports corresponding to the typical 24-V 4800 bps system in microcomputers.

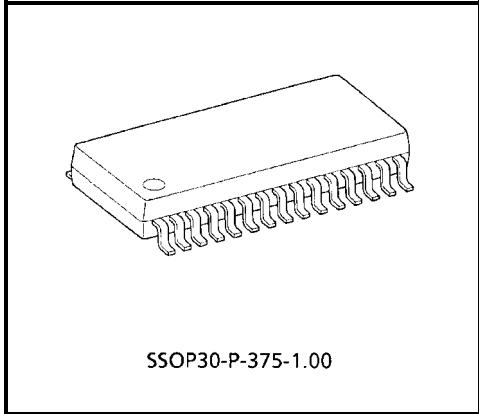

Weight: 0.63 g (Typ.)

### FEATURES

- Accurate output : 5V ± 0.25 V
- Output PNP Tr incorporated : Current capacity ; 300 mA (max)
- Power-on Reset timer incorporated
- Watchdog timer incorporated
- Small flat package sealing : SSOP30 pin (1 mm pitch)

● Difference 1

CHARACTERISTIC	TD62650 / 652F	TD62651F
Reset Detecting Voltage	5V / 92%	5V / 85%

● Difference 2

Time setting resistance 22 kΩ for power-on reset / watchdog timer, and PULL resistance of 4.7 kΩ for RESET pin.

TD62650F	TD62651F	TD62652F
Built-in	None	None

### PIN CONNECTION

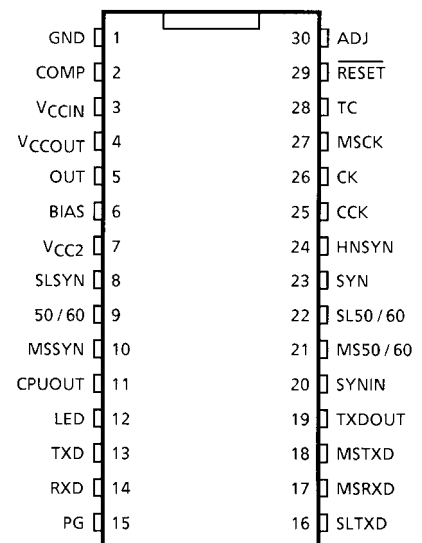

**TD62650F BLOCK DIAGRAM**

**5V POWER SUPPLY + SUPPLY MONITORING**

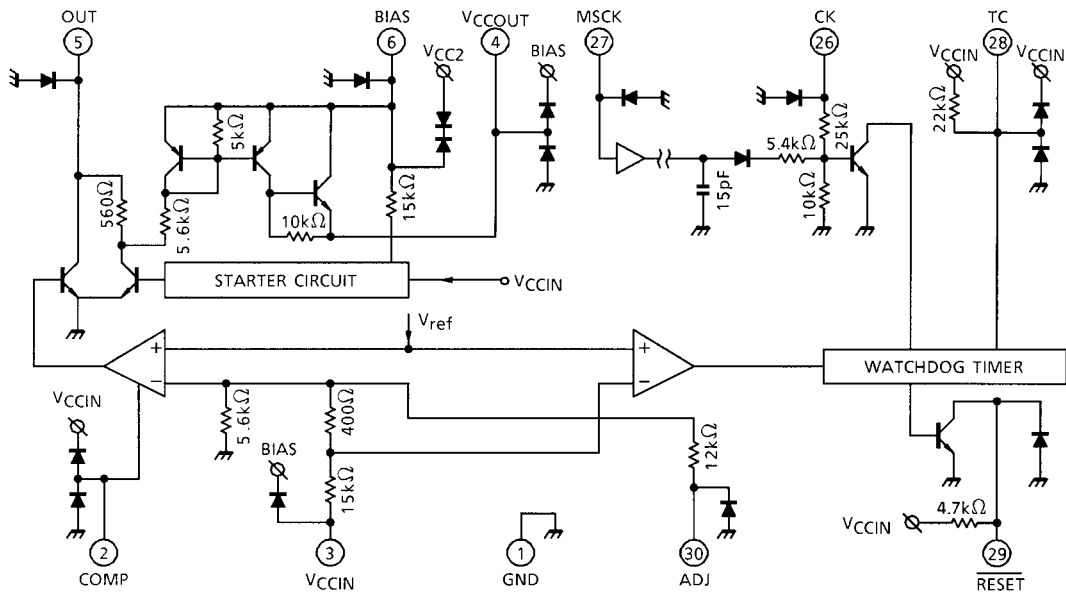

**INTERFACE**

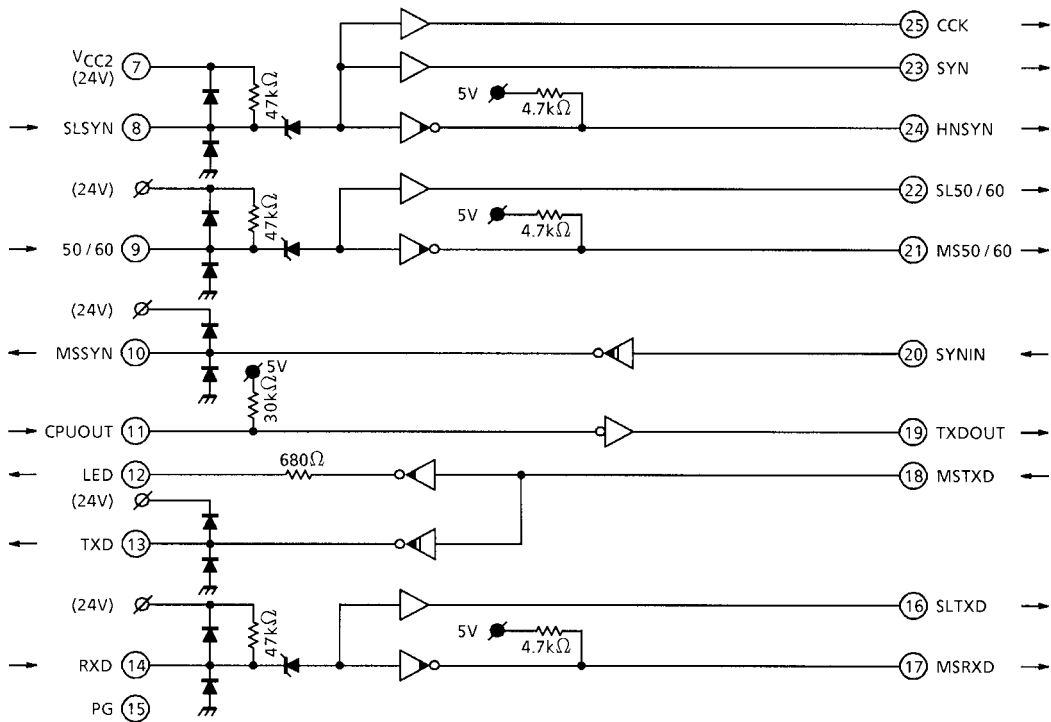

: 5-V System Push Pull INV 
 : 5-V System Open Collector 
 : 24-V System Open Collector 
 : 5-V System Push Pull Buffer

**TD62651F / TD62652F BLOCK DIAGRAM**

**5V POWER SUPPLY + SUPPLY MONITORING**

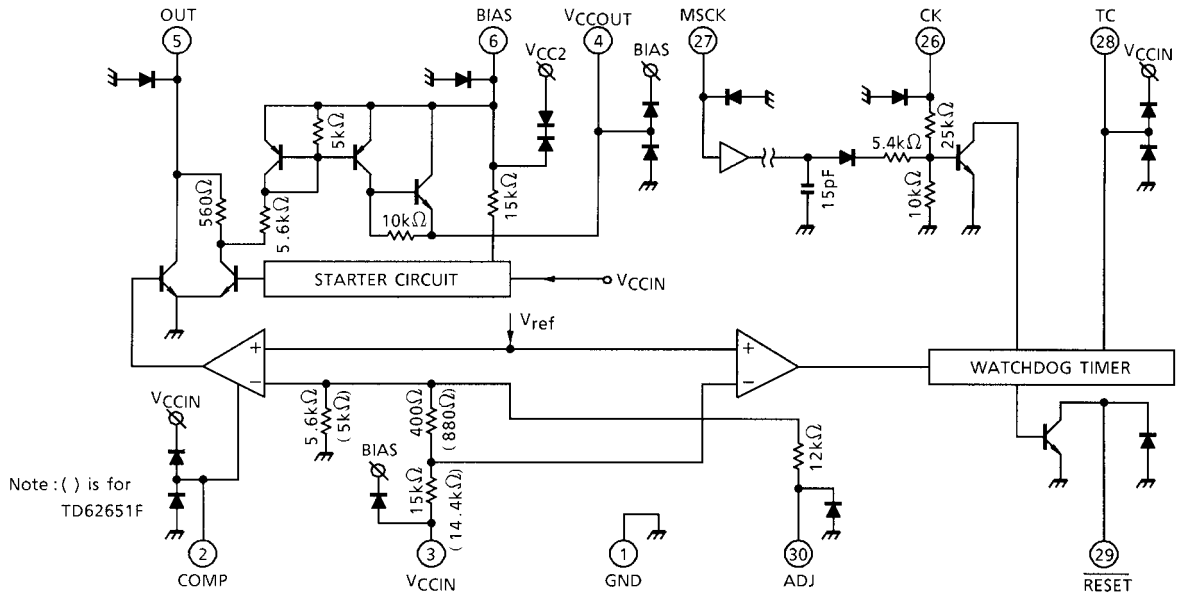

**INTERFACE**

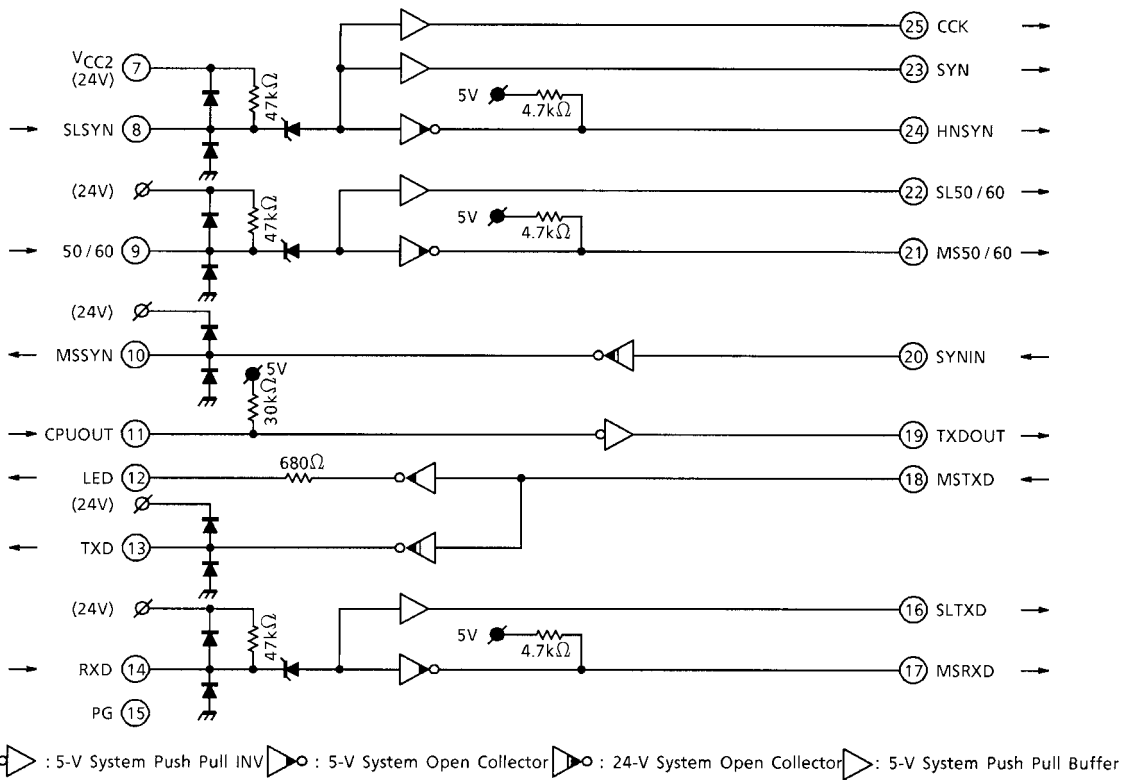

## INTERFACE INPUT / OUTPUT CIRCUITS

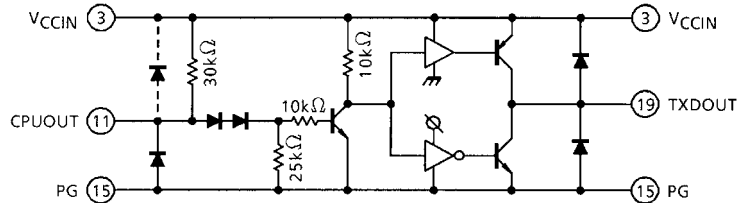
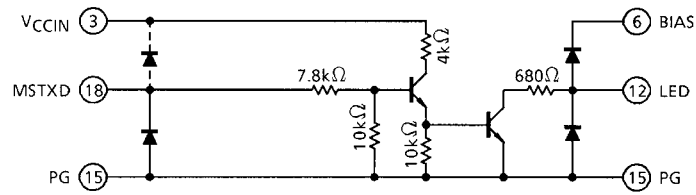
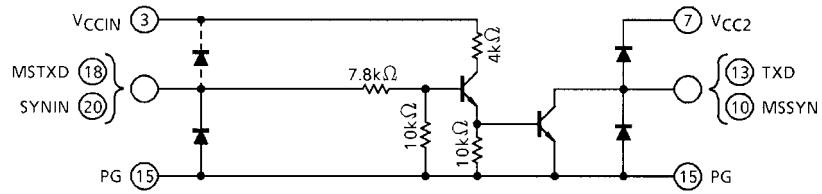
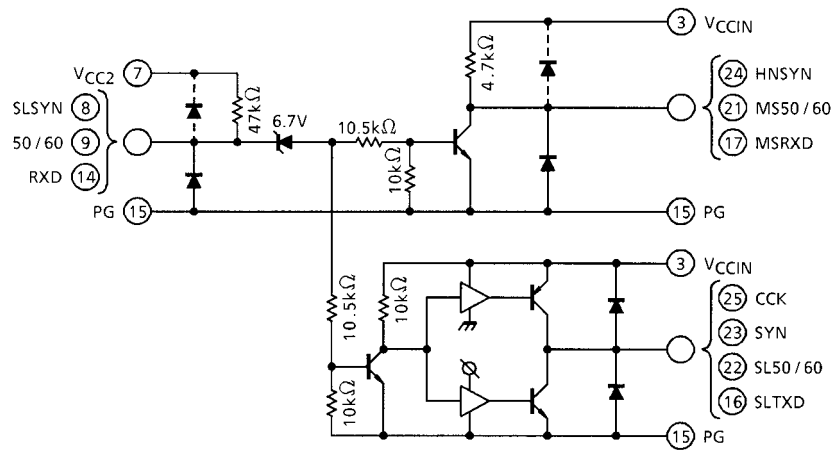

## PIN FUNCTION

PIN No.	PIN NAME	PIN FUNCTION
1	GND	GND pin for 5 V power supply and supply monitoring.
2	COMP	Phase compensation pin for output stabilization.
3	VCCIN	Power supply pin for internal circuit. The output voltage can also be detected at this pin.
4	VCCOUT	Output pin for built-in Power Tr, having a current capacitance of 300 mA (max). It is also used as an output pin for 5 V constant power supply through shorting with VCCIN pin.
5	OUT	Connected to the base of an external PNP transistor so that the output voltage is stabilized. Current design suitable for load capacities is thus possible. Since the recommended I <sub>OUT</sub> current is 5 mA, an output current of 300 mA is assured if the external transistor has an hFE of 60. When the internal transistor is used, it can be opened.
6	BIAS	Power supply starting pin. The starting current is supplied through a resistor to which the input voltage is applied. When VCCIN rises above 3.0 V, the starting current is absorbed in the internal circuit ; instead, I <sub>OUT</sub> is supplied via VCCIN.
7	VCC2	Power supply pin for the 24-V system.
8	SLSYN	Input pin for the 24-V system interface. Pull-up resistor 47 kΩ is incorporated at VCC2 pin.
9	50 / 60	Input pin for 24-V system interface. Pull-up resistor 47 kΩ is incorporated at VCC2 pin.
10	MSSYN	Output pin for the 24-V system open collector.
11	CPUOUT	Input pin for the 5-V system Push / Pull inverter. Pull-up resistor 30 kΩ is incorporated at VCCIN pin.
12	LED	LED lighting pin for the 8 system open collector. 680 Ω limiting resistor is incorporated.
13	TXD	Output pin for the 24-V system open collector.
14	RXD	Input pin for the 24-V system interface. Pull-up resistor 47 kΩ is incorporated at the VCC2 pin.
15	PG	GND pin for the 5-V / 24-V system interfaces.
16	SLTXD	Output pin for the 5-V system open collector. Pull-up resistor 4.7 kΩ is incorporated at the VCCIN pin.
17	MSRXD	Output pin for the 5-V system Push-Pull buffer.
18	MSTXD	Input pin for the 5-V system interface, for input at LED (12 pin) and TXD (13 pin) pins.
19	TXDOUT	Output pin for the 5-V system Push / Pull inverter (CPUOUT : 11 pin).
20	SYNIN	Input pin for the 5-V system interface.
21	MS50 / 60	Output pin for the 5-V system open collector. Pull-up resistor 4.7 kΩ is incorporated at VCCIN pin.
22	SL50 / 60	Output pin for the 5-V system Push / Pull buffer.
23	SYN	Output pin for the 5-V system Push-Pull buffer.
24	HNSYN	Output pin for the 5-V system open collector. Pull-up resistor 4.7 kΩ incorporated at VCCIN pin.
25	CCK	Output pin for the 5-V system Push-Pull buffer.

PIN No.	PIN NAME	PIN FUNCTION
26	CK	Input pin for watchdog timer. The pin is pulled up to $V_{CCIN}$ if the IC is used only as a power-on reset timer.
27	MSCK	To input clock pulses, one-shot pulses can be generated for CK (26 pin) inputs at the rise edge. When the pin is not used, short it with GND.
28	TC	Time setting pin for the reset and watchdog timers.
29	$\overline{\text{RESET}}$	<p>NPN transistor open-collector output.</p> <p>(1) The signal goes low when the output voltage drops below the specified 92% (TD62650 / 652) or 85% (651F) level.</p> <p>(2) The pin generates a reset signal that is determined by the external condenser connected to the TC pin.</p> <p>(3) The pin generates reset pulses intermittently if no clock is attached to the CK pin.</p> <p>This function can be used as a watchdog timer for microcomputers.</p>
30	ADJ	Output voltage adjusting pin. The voltage will increase when a resistor is connected between ADJ and GND (1 pin). It can reduce the voltage when the resistor is inserted between ADJ and $V_{CCIN}$ (3 pin). The voltage can be changed by a maximum of $\pm 1V$ .

**TIMING CHART (TD62650F, TD62652F)**

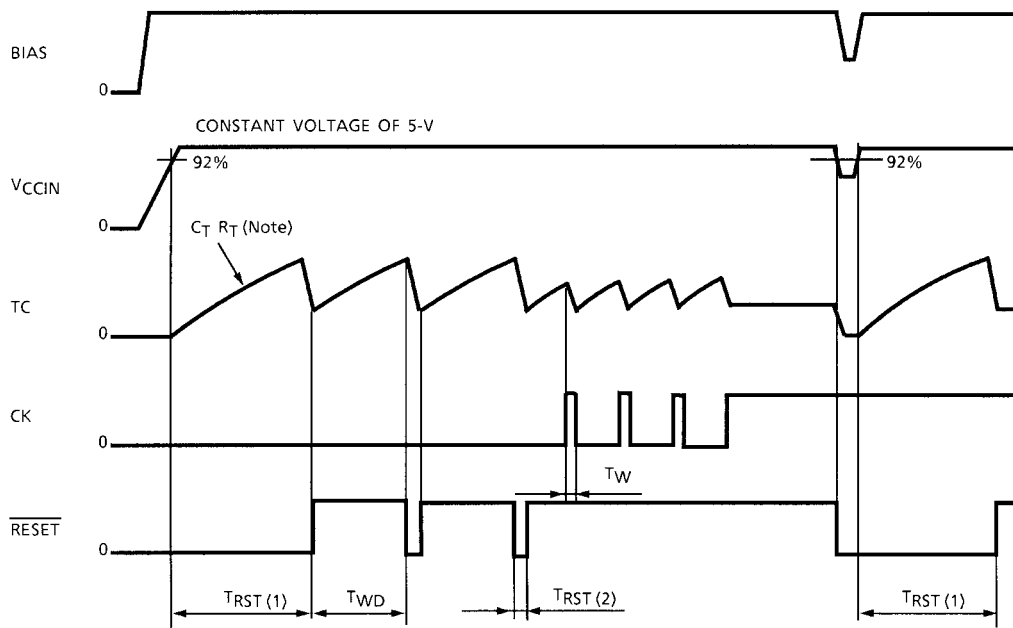

Note: TD6250F incorporates RT (22kΩ (Typ.)) only for CT.)

**TIMING CHART (TD62651F)**

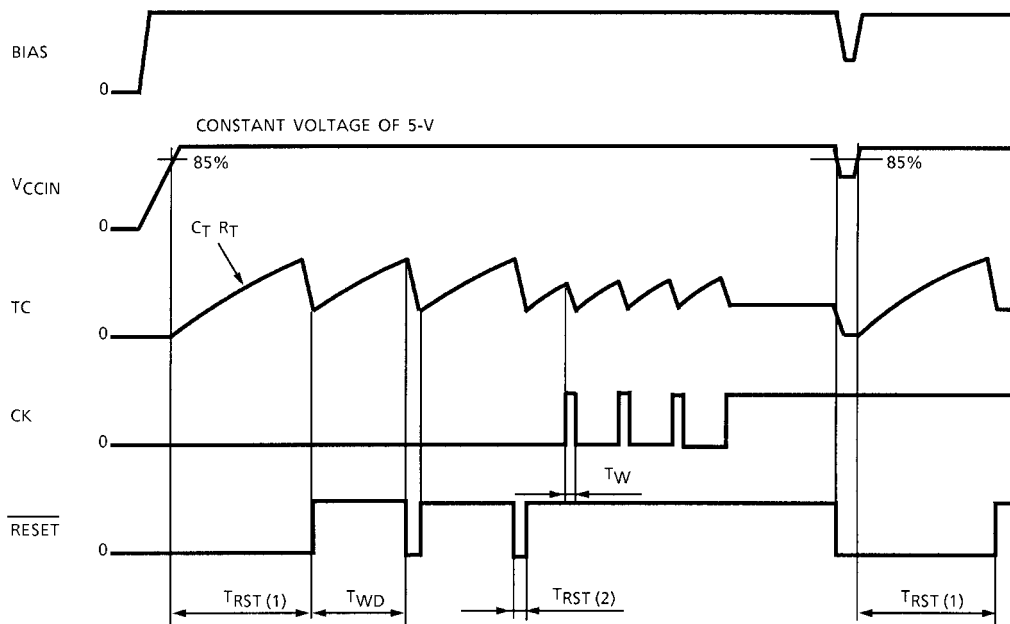

## MAXIMUM RATINGS (Ta = 25°C)

CHARACTERISTIC	SYMBOL	RATING	UNIT	PIN
Input Voltage	V <sub>VCC24</sub>	-0.4~35	V	V <sub>CC2</sub> , BIAS
	V <sub>VCCIN</sub>	-0.4~7	V	V <sub>CCIN</sub>
	V <sub>IN24</sub> (Condition 1) (Condition 2)	-0.4~V <sub>VCC2</sub> + 0.4~0.4~30	V	SLSYN, 50 / 60, RXD
	V <sub>IN5</sub>	-0.4~V <sub>VCCIN</sub> + 0.4	V	CPUOUT, MSCK, ADJ, COMP, CK, TC, SYNIN, MSTXD
Output Voltage	V <sub>OUT24</sub>	-0.4~V <sub>VCC2</sub> + 0.4	V	MSSYN, TXD
	V <sub>VCCOUT</sub>	-0.4~V <sub>BIAS</sub> + 0.4	V	V <sub>CCOUT</sub> , OUT
	V <sub>LED</sub> (Condition 3) (Condition 4)	-0.4~V <sub>BIAS</sub> + 0.4~0.4~10	V	LED
	V <sub>OUT5</sub>	-0.4~V <sub>VCCIN</sub> + 0.4	V	RESET, CCK, HNSYN, SYN, SL50 / 60, MS50 / 60, TXDOUT, MSRXD, SLTXD
Output Current	I <sub>OUT</sub>	10	mA	OUT
	I <sub>RESET</sub>	4	mA	RESET
	I <sub>OUT Push / Pull</sub>	±4	mA / ch	CCK, SYN, SL50 / 60, TXDOUT, SLTXD
	I <sub>OUT5</sub>	10	m / ch	HNSYN, MS50 / 60, LED, MSRXD
	I <sub>OUT24</sub>	24	mA / ch	MSSYN, TXD
	I <sub>VCCOUT</sub>	300	mA	V <sub>CCOUT</sub>
Power Dissipation	P <sub>D</sub> (Note 5)	1.47	W	
Operating Temperature	T <sub>opr</sub>	-40~85	°C	
Storage Temperature	T <sub>stg</sub>	-55~150	°C	

Condition 1: V<sub>VCC2</sub> ≤ 29.6 V

Condition 2: V<sub>VCC2</sub> > 29.6 V

Condition 3: V<sub>BIAS</sub> ≤ 9.6 V

Condition 4: V<sub>BIAS</sub> > 9.6 V

Note 5: Board mounting time (50 × 50 × 1.6 mm, Cu = 30%)



## DC ELECTRICAL CHARACTERISTICS (Ta = 25°C, VCCIN = 5 V)

### Interface Section

CHARACTERISTIC	SYMBOL	PIN	TEST CIR-CUIT	TEST CONDITION	MIN	TYP.	MAX	UNIT
Input Voltage	V <sub>IH5</sub>	(Note 1)	—		V <sub>CCIN</sub> × 70%	—	—	V
	V <sub>IL5</sub>				—	—	V <sub>CCIN</sub> × 30%	
	V <sub>IH24</sub>	(Note 1)			13	—	V <sub>CC2</sub> + 0.4	
	V <sub>IL24</sub>				-0.4	—	7	
Input Current	I <sub>IH5-1</sub>	(Note 3)	—	V <sub>IN</sub> = 5 V	320	462	600	μA / ch
	I <sub>IL5-1</sub>			V <sub>IN</sub> = 0 V	—	0	10	μA
	I <sub>IH5-2</sub>	(Note 7)		V <sub>IN</sub> = 5 V	480	690	940	
	I <sub>IL5-2</sub>			V <sub>IN</sub> = 0 V	115	170	240	
	I <sub>IH24</sub>	(Note 2)		V <sub>IN</sub> = 24 V	1.1	1.6	2.1	mA / ch
	I <sub>IL24</sub>			V <sub>IN</sub> = 0 V	350	510	690	μA
Output Voltage	V <sub>OH5-1</sub>	(Note 4)	—	I <sub>OH</sub> = -20 μA	V <sub>CC</sub> - 0.1	—	—	V
	V <sub>OH5-2</sub>			I <sub>OH</sub> = -4 mA	V <sub>CCIN</sub> × 70%	—	—	
	V <sub>OL5-1</sub>			I <sub>OL</sub> = 20 μA	—	—	0.1	
	V <sub>OL5-2</sub>			I <sub>OL</sub> = 4 mA	—	—	V <sub>CCIN</sub> × 30%	
	V <sub>OL5-3</sub>	(Note 5)		I <sub>IN</sub> = 500 μA I <sub>OL</sub> = 10 mA	—	—	0.5	
	V <sub>OL LED</sub>	LED		I <sub>IN</sub> = 200 μA I <sub>OL</sub> = 1 mA	—	—	1.4	
	V <sub>OL24</sub>	(Note 6)		I <sub>IN</sub> = 200 μA I <sub>OL</sub> = 24 mA	—	—	0.5	
Output Impedance	R <sub>OL LED</sub>	LED	—	(Note 8)	540	680	1000	Ω
	R <sub>OH5</sub>	(Note 5)		(Note 9)	3.2	4.7	6.2	kΩ
Current Consumption 24	I <sub>VCC2</sub>		—	V <sub>VCC2</sub> = 24 V	—	1.6	2.1	mA
Leakage Current	I <sub>LEAK24</sub>	(Note 6)	—	V <sub>OH</sub> = 24.0 V	—	—	10	μA
	I <sub>LEAK5</sub>	(Note 4)		V <sub>OH</sub> = 5 V	—	—	10	
Output Shorting Current	I <sub>OS</sub> (Note)	(Note 4)	—	V <sub>CCIN</sub> = 5.25 V V <sub>OH</sub> = 0 V	—	17.5	—	mA

Note: Two outputs or more must not be shorted at the same time.

Shorting duration must be limited to less than 1 second.

Note 1: CPUOUT, SYNIN, MSTXD

Note 5: HNSYN, MS50 / 60, MSRXD

Note 2: SLSYN, 50 / 60, RXD

Note 6: MSSYN, TXD

Note 3: SYNIN, MSTXD

Note 7: CPUOUT

Note 4: CCK, SYN, SL50 / 60, TXDOUT, SLTXD

Note 8: (V<sub>OL</sub> (@I<sub>OL</sub> = 5 mA) - V<sub>OL</sub> (@I<sub>OL</sub> = 1 mA)) ÷ 4 mA

Note 9: 4 V ÷ (@I<sub>OH</sub> (V<sub>OH</sub> = 0 V) - @I<sub>OH</sub> (V<sub>OH</sub> = 4 V))

**DC ELECTRICAL CHARACTERISTICS**

(Unless otherwise specified,  $V_{BIAS} = 7$  to  $17$  V,  $T_a = -40$  to  $85^\circ\text{C}$ )

5V power supply, supply monitoring section

CHARACTERISTIC	SYMBOL	TEST CIR-CUIT	TEST CONDITION	MIN	TYP.	MAX	UNIT
Output Voltage	$V_{CCOUT}$	—	$I_{VCCOUT} = 0.1$ A	4.75	5.0	5.25	V
Input Stability	$V_{CCOUT}$ LINE	—	$V_{BIAS} = 7\sim 35$ V	—	0.1	0.5	%
Load Stability	$V_{CCOUT}$ LOAD	—	$I_{VCCOUT} = 1\sim 150$ mA	—	0.1	0.5	%
Temperature Coefficient	$V_{CCOUT}$ t	—		—	0.01	—	% / $^\circ\text{C}$
Output Voltage	$V_{OL}$ $\overline{\text{RESET}}$	—	$I_{OL} = 2$ mA	—	—	0.5	V
Output Leakage Current	$\frac{I_{LEAK}}{\overline{\text{RESET}}}$	—	$V_{\overline{\text{RESET}}} = 7$ V	—	—	5	$\mu\text{A}$
Input Current	$I_{TC}$	—	$V_{TC} = 0$ to $3.5$ V (Note 8)	-3	—	3	$\mu\text{A}$
Threshold Voltage	$V_{TC}$ H	—	$\overline{\text{RESET}}$ "High" to "Low"	—	$80\% \times V_{CCIN}$	—	V
	$V_{TC}$ L	—	$\overline{\text{RESET}}$ "Low" to "High"	—	$40\% \times V_{CCIN}$	—	
Input Current	$I_{CK}$	—	$V_{IN} = 5$ V (Note 8)	—	0.3	0.7	mA
Input Voltage	$V_{IH}$	—	(Note 4)	$V_{CCIN} \times 70\%$	—	—	V
	$V_{IL}$	—		—	—	$V_{CCIN} \times 30\%$	
Reset Detecting Voltage	$V_{CC}$ $\overline{\text{RESET}}$	—	TD62650 / 652F	$89\% \times V_{CCIN}$	$92\% \times V_{CCIN}$	$95\% \times V_{CCIN}$	V
			TD62651F	$82\% \times V_{CCIN}$	$85\% \times V_{CCIN}$	$88\% \times V_{CCIN}$	
Output Impedance	$\frac{R_{OH}}{\overline{\text{RESET}}}$	—	TD62650F (Note 1)	3.2	4.7	6.2	k $\Omega$
	$R_{OH}$ TC	—	TD62650F (Note 1)	15	22	29	
Current Consumption 5	$I_{VCCIN}$	—	(Note 2)	—	5	6.5	mA
			(Note 5)	—	11.5	15.0	
Bias Current Consumption	$I_{BIAS}$	—	$V_{BIAS} = 8$ V (Note 7)	—	1.73	2.25	mA
Watchdog Timer	$T_{WD}$	—	TD62650F (Note 6)	$15.4 \times \text{CT}$	$24.2 \times \text{CT}$	$33.0 \times \text{CT}$	ms
			TD62651 / 2F	$0.9 \times \text{CTRTRT}$	$1.1 \times \text{CTRTRT}$	$1.3 \times \text{CTRTRT}$	s
Reset Timer (1) (Note 3)	$T_{RST}$ (1)	—	TD62650F (Note 6)	$24.2 \times \text{CT}$	$35.2 \times \text{CT}$	$48.4 \times \text{CT}$	ms
			TD62651 / 2F	$1.3 \times \text{CTRTRT}$	$1.6 \times \text{CTRTRT}$	$1.9 \times \text{CTRTRT}$	s
Reset Timer (Note 3)	$T_{RST}$ (2)	—	(Note 6)	$300 \times \text{CT}$	$600 \times \text{CT}$	$900 \times \text{CT}$	ms

CHARACTERISTIC	SYMBOL	TEST CIR-CUIT	TEST CONDITION	MIN	TYP.	MAX	UNIT
Clock Input Pulse width	TW CK	—		3	—	—	μs
Maximum Response Frequency 1	f <sub>MAX</sub> MSCK	—		2	—	—	kHz
Maximum Response Frequency 2	f <sub>MAX</sub> CK	—		10	—	—	kHz
Msck Pin Input Signal Rise Time	tr MSCK	—	(Note 9)	—	—	500	ns
Minimum Input / Output Voltage Difference	V <sub>OH</sub> V <sub>CCOUT</sub>	—	I <sub>VCCOUT</sub> = 0.1 A	—	—	1.5	V

Note 1: 4 V ÷ (@I<sub>OH</sub> (V<sub>OH</sub> = 0 V) - @I<sub>OH</sub> (V<sub>OH</sub> = 4 V)

Note 2: V<sub>BIAS</sub> = 8 V, V<sub>CCIN</sub> - V<sub>CCOUT</sub> Short

Open Collector I / O : Open

Push-Pull I / O : Open

MSCK Input : Open

Note 3: Reset Timer (1) : Power On Reset Time

Reset Timer (2) : Watchdog Reset Time

Note 4: MSCK, CK Pins

Note 5: HNSYN, MS50 / 60, MSRXD Pull / UP Resistance + CCK, SYN, SL50 / 60, TXDOUT, SLTXD Driving Current

Note 6: CT Unit (μF)

Note 7: V<sub>CCIN</sub>, V<sub>CCOUT</sub> Open

Note 8: Only TD62651F, TD62652F

Note 9: Input Condition 5 V : 0 to 100%

**AC ELECTRICAL CHARACTERISTICS (Ta = 25°C)**

CHARACTERISTIC	CHARACTERISTIC / INPUT CONDITION	SYMBOL	TEST CIR-CUIT	OUTPUT CONDITION	MIN	TYP.	MAX	UNIT
Propagation Delay Time (tpLH: 50%–50%, tpHL: 50%–50%)	SLSYN-CCK (Note 1)	tpLH	—	(Note 4)	—	0.6	—	μs
		tpHL			—	1.5	—	
	SLSYN-SYN (Note 1)	tpLH		(Note 4)	—	0.6	—	
		tpHL			—	1.5	—	
	SLSYN-HNSYN (Note 1)	tpLH		(Note 5)	—	0.5	—	
		tpHL			—	0.1	—	
	50 / 60-MS50 / 60 (Note 1)	tpLH		(Note 5)	—	0.5	—	
		tpHL			—	0.1	—	
	50 / 60-SL50 / 60 (Note 1)	tpLH		(Note 4)	—	0.6	—	
		tpHL			—	1.5	—	
	SYNIN-MSSYN (Note 2)	tpLH		(Note 3)	—	1.0	—	
		tpHL			—	0.1	—	
	CPUOUT-TXDOUT (Note 2)	tpLH		(Note 4)	—	1.0	—	
		tpHL			—	1.2	—	
	MSTXD-LED (Note 2)	tpLH		(Note 5)	—	0.5	—	
		tpHL			—	0.1	—	
MSTXD-TXD (Note 2)	tpLH	(Note 3)	—	1.0	—			
	tpHL		—	0.1	—			
RXD-SLTXD (Note 1)	tpLH	(Note 4)	—	0.6	—			
	tpHL		—	1.5	—			
RXD-MSRXD (Note 1)	tpLH	(Note 5)	—	0.5	—			
	tpHL		—	0.1	—			
Rise Time (tr: 10%–90%)	MS50 / 60	tr	—		—	0.3	—	μs
	SL50 / 60				—	0.2	—	
	LED				—	0.2	—	
	MSSYN				—	1.1	—	
	TXDOUT				—	0.2	—	
	TXD				—	1.1	—	
	SYN				—	0.2	—	
	CCK				—	0.2	—	
	HNSYN				—	0.3	—	
	SLTXD				—	0.2	—	
	MSRXD				—	0.3	—	

CHARACTERISTIC	CHARACTERISTIC / INPUT CONDITION	SYMBOL	TEST CIR-CUIT	TEST CONDITION	MIN	TYP.	MAX	UNIT
Fall Time (tr: 90%–10%)	MS50 / 60	tf	—		—	0.1	—	μs
	SL50 / 60				—	0.5	—	
	LED				—	0.1	—	
	MSSYN				—	0.1	—	
	TXDOUT				—	0.5	—	
	TXD				—	0.1	—	
	SYN				—	0.5	—	
	CCK				—	0.5	—	
	HNSYN				—	0.1	—	
	SLTXD				—	0.5	—	
	MSRXD				—	0.1	—	

Input / Output Conditions

- Input Condition

- Note 1: 24-V System : 0.2μs at 2 to 22-V
- Note 2: 5-V System : 0.1μs at 30 to 70%

- Output Conditions

- Note 3: 24-V System : C<sub>L</sub> = 50 pF
- Note 4: 5-V System : C<sub>L</sub> = 50 pF  
R<sub>L</sub> = 5 kΩ
- Note 5: 5-V System : C<sub>L</sub> = 50 pF

**APPLICATION CIRCUIT**

When using an external PNP transistor :

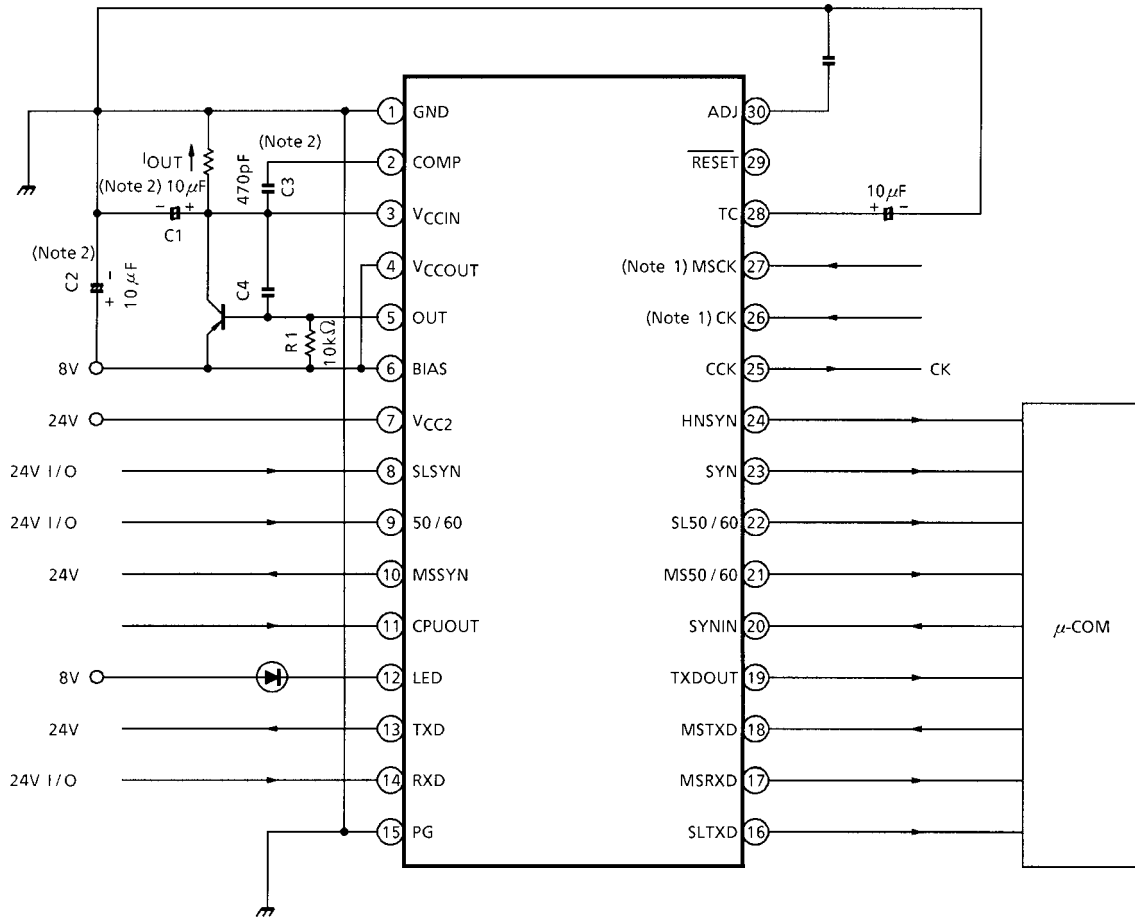

Note 1: When using the MSCK pin, short circuit the CK pin with GND.

When using the CK pin, short circuit the MSCK pin with GND.

Note 2: C1 and C2 are necessary to absorb external noise, etc. Connect them as close to the IC as possible.

C3 is used for phase correction, but this also must be connected as close to the IC as possible.

We recommend that C4 be connected between OUT and VCCIN.

**PRECAUTIONS for USING**

This IC does not integrate protection circuits such as overcurrent and overvoltage protectors.

Thus, if excess current or voltage is applied to the IC, the IC may be damaged. Please design the IC so that excess current or voltage will not be applied to the IC.

Utmost care is necessary in the design of the output line, VCC (VCCIN, VCCOUT, BIAS, VCC2) and GND line since IC may be destroyed due to short-circuit between outputs, air contamination fault, or fault by improper grounding.

When using a built-in PNP transistor :

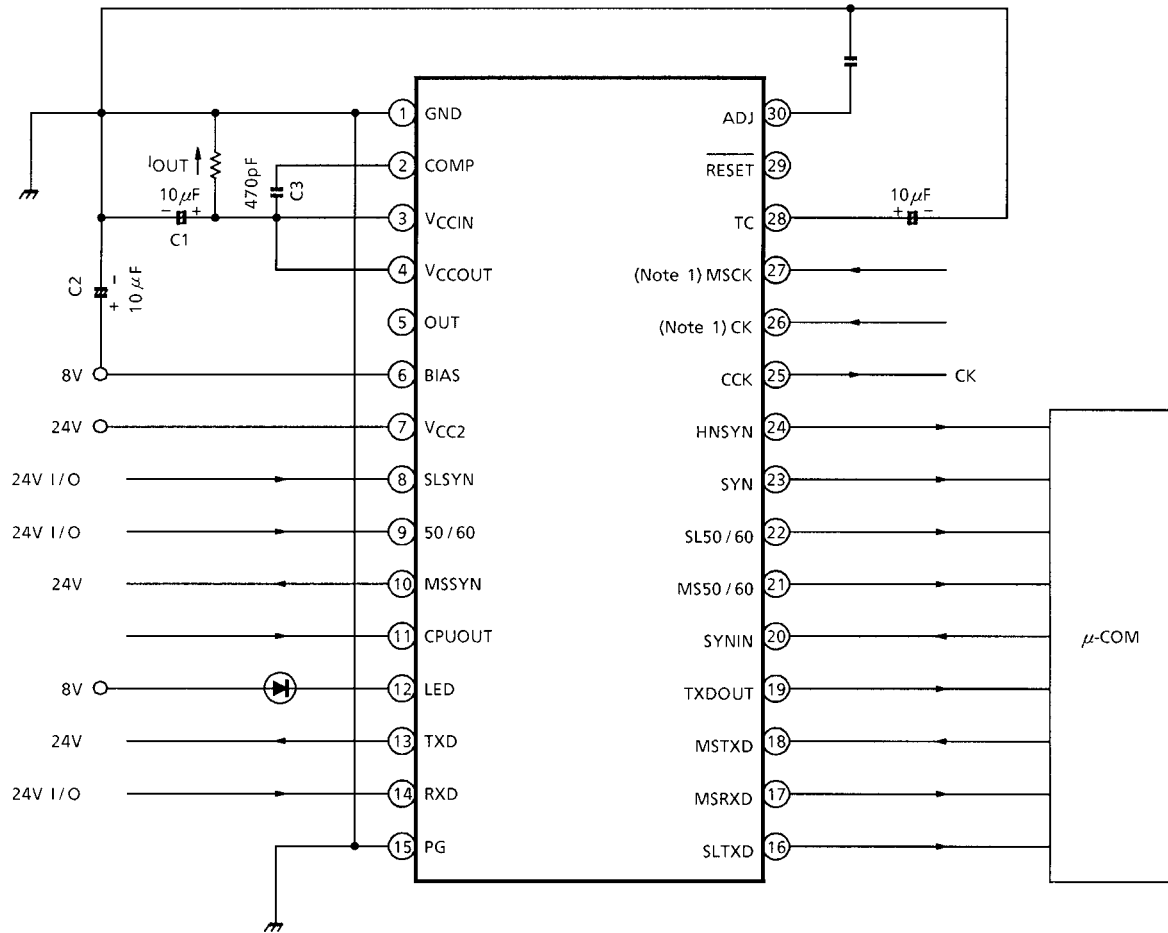

Note 1: When using the MSCK pin, short the CK pin with GND.

When using the CK pin, short the MSCK pin with GND.

Note 2: C1 and C2 are necessary to absorb external noise, etc.

Connect them as close to the IC as possible.

C3 is used for phase correction, but this also must be connected as close to the IC as possible.

## PACKAGE DIMENSIONS

SSOP30-P-375-1.00

Unit: mm

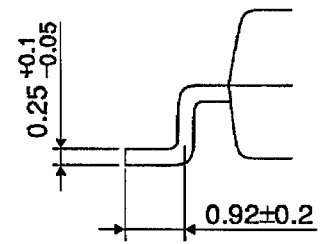
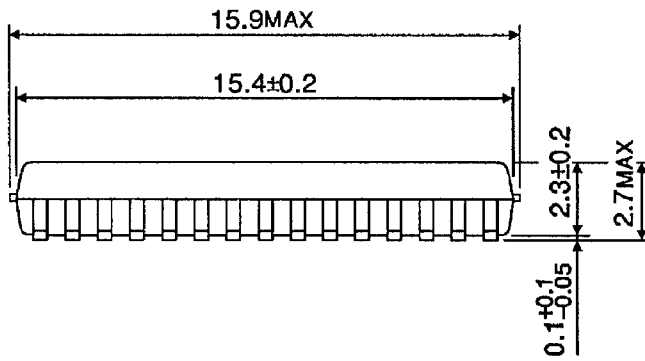
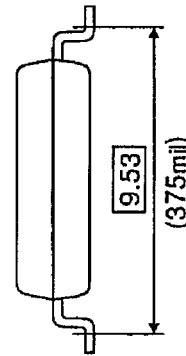
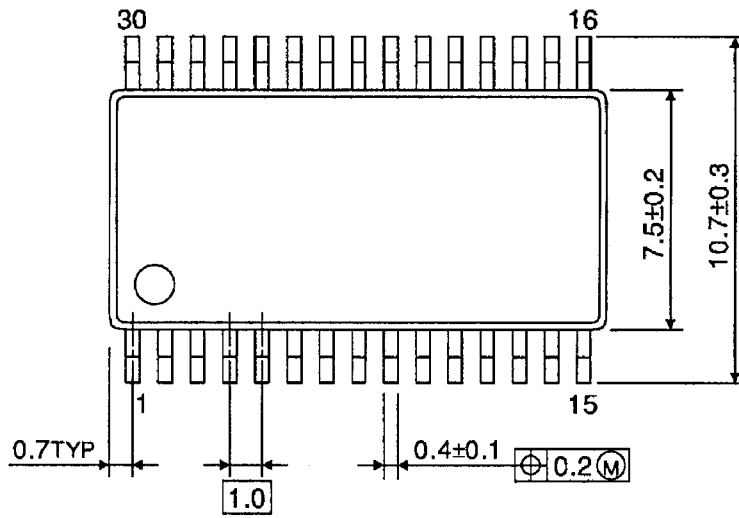

Weight: 0.63 g (Typ.)



**RESTRICTIONS ON PRODUCT USE**

000707EBA

- TOSHIBA is continually working to improve the quality and reliability of its products. Nevertheless, semiconductor devices in general can malfunction or fail due to their inherent electrical sensitivity and vulnerability to physical stress. It is the responsibility of the buyer, when utilizing TOSHIBA products, to comply with the standards of safety in making a safe design for the entire system, and to avoid situations in which a malfunction or failure of such TOSHIBA products could cause loss of human life, bodily injury or damage to property.  
In developing your designs, please ensure that TOSHIBA products are used within specified operating ranges as set forth in the most recent TOSHIBA products specifications. Also, please keep in mind the precautions and conditions set forth in the "Handling Guide for Semiconductor Devices," or "TOSHIBA Semiconductor Reliability Handbook" etc..
- The TOSHIBA products listed in this document are intended for usage in general electronics applications (computer, personal equipment, office equipment, measuring equipment, industrial robotics, domestic appliances, etc.). These TOSHIBA products are neither intended nor warranted for usage in equipment that requires extraordinarily high quality and/or reliability or a malfunction or failure of which may cause loss of human life or bodily injury ("Unintended Usage"). Unintended Usage include atomic energy control instruments, airplane or spaceship instruments, transportation instruments, traffic signal instruments, combustion control instruments, medical instruments, all types of safety devices, etc.. Unintended Usage of TOSHIBA products listed in this document shall be made at the customer's own risk.
- The products described in this document are subject to the foreign exchange and foreign trade laws.
- The information contained herein is presented only as a guide for the applications of our products. No responsibility is assumed by TOSHIBA CORPORATION for any infringements of intellectual property or other rights of the third parties which may result from its use. No license is granted by implication or otherwise under any intellectual property or other rights of TOSHIBA CORPORATION or others.
- The information contained herein is subject to change without notice.