

General Description

The TD8202A/B/C is a current-mode and fixed frequency boost converter with an integrated N-FET to drive up to 8 white LEDs in series.

The series connection allows the LED current to be identical for uniform brightness. Its low on-resistance of NFET and feedback voltage reduce power loss and achieve high efficiency. Fast 1MHz current-mode PWM operation is available for input and output capacitors and a small inductor while minimizing ripple on the input supply. The OVP pin monitors the output voltage and stops switching if exceeds the over-voltage threshold. An internal softstart circuit eliminates the inrush current during start-up.

The TD8202A/B/C also integrates under-voltage lockout, over-temperature protection, and current-limit circuits. The TD8202/A/B/C is available in a SOT-23-6 packages.

Features

- Wide Input Voltage from 2.7V to 6V
- 0.25V Reference Voltage
- Fixed 1MHz Switching Frequency
- High Efficiency up to 87%
- 100Hz to 100kHz PWM Brightness Control Frequency
- Open-LED Protection
- Under-Voltage Lockout Protection
- Over-Temperature Protection
- <1mA Quiescent Current Dduring Shutdown
- SOT-23-6 Packages
- Lead Free and Green Devices Available
- (RoHS Compliant)

Applications

- White LED Display Backlighting
- Cell Phone and Smart Phone
- PDA, PMP, MP3
- Digital Camera

Pin Assignments

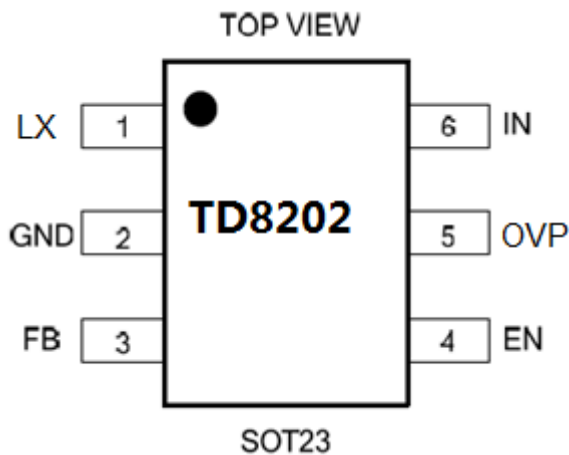

Pin Description

Pin Number	Pin Name	Description
1	LX	Switch pin. Connect this pin to inductor/diode here.
2	GND	Ground
3	FB	Feedback Pin. Reference voltage is 0.25V. Connect this pin to cathode of the lowest LED and resistor (R1). Calculate resistor value according to $R1=0.25V/I_{LED}$.
4	EN	Enable Control Input. Forcing this pin above 1.0V enables the device, or forcing this pin below 0.4V to shut it down. In shutdown, all functions are disabled to decrease the supply current below 1µA. Do not leave this pin floating.
5	OVP	Converter Output and Over-Voltage Protection Input Pin.
6	IN	Main Supply Pin. Must be closely decoupled to GND with a 4.7µF or greater ceramic capacitor.

Ordering Information

TD8202 □ □ □

Circuit Type
 OVP Voltage Code
 A:20V B:28V C:35V

Packing:
 Blank: Tube

Package
 T:SOT23

Functional Block Diagram

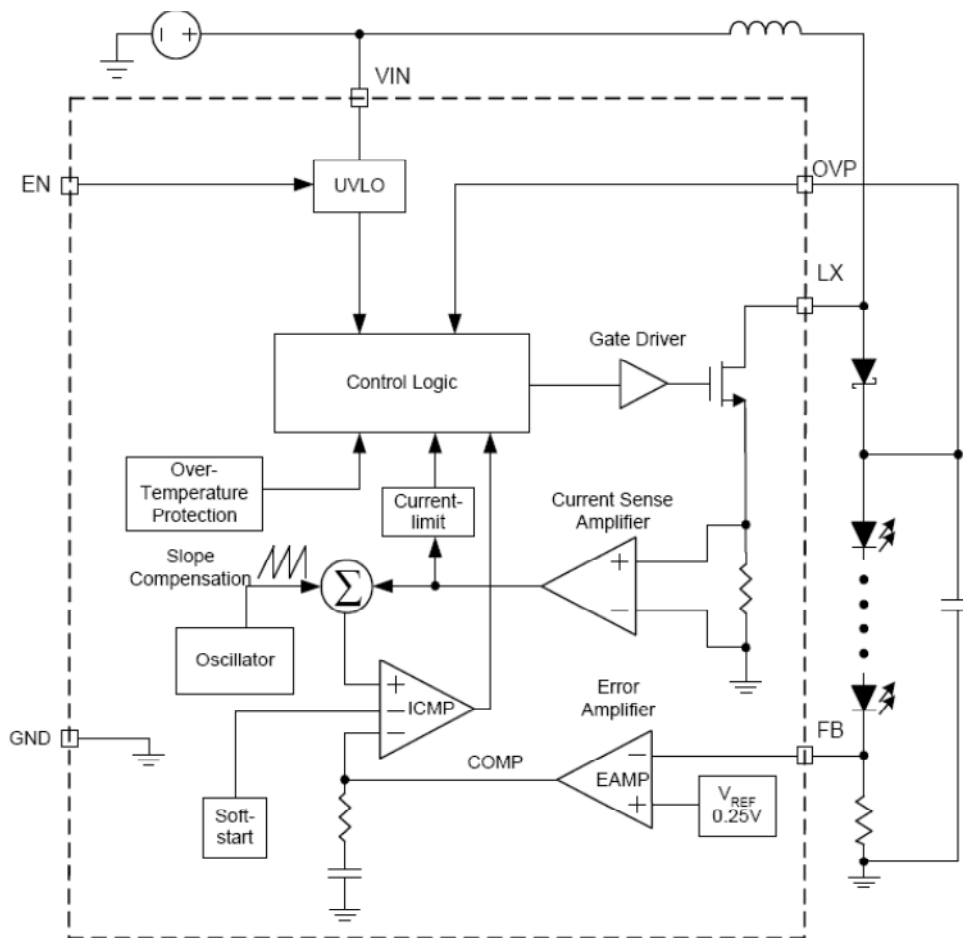

Functional Block Diagram of TD8202

Absolute Maximum Ratings

Symbol	Parameter	Rating	Unit
V_{IN}	VIN Supply Voltage (VIN to GND)	-0.3 ~ 8	V
	FB, EN to GND Voltage	-0.3 ~ V_{IN}	V
V_{LX}	LX to GND Voltage	-0.3 ~ 38	V
V_{OVP}	OVP to GND Voltage	-0.3 ~ 38	V
T_J	Maximum Junction Temperature	150	°C
T_{STG}	Storage Temperature Range	-65 ~ 150	°C
T_{SDR}	Maximum Lead Soldering Temperature, 10 Seconds	260	°C

Recommended Operating Conditions

Symbol	Parameter	Range	Unit
V_{IN}	VIN Input Voltage	2.7~ 6	V
V_{OUT}	Converter Output Voltage	Up to 32	V
C_{IN}	Input Capacitor	4.7 or higher	F
C_{OUT}	Output Capacitor	0.68 or higher	F
L1	Inductor	6.8 to 47	H
T_A	Ambient Temperature	-40 to 85	°C
T_J	Junction Temperature	-40 to 125	°C

1MHz, High-Efficiency, Step-Up Converter for 2 to 8 White LEDs TD8202

Electrical Characteristics

The following specifications apply for $V_{IN}=3.6V$ $T_A=25^\circ C$, unless specified otherwise.

Symbol	Parameter	Test Conditions	TD8202A/B/C			Unit
			Min.	Typ.	Max.	
SUPPLY VOLTAGE AND CURRENT						
V_{IN}	Input Voltage Range	$T_A = -40 \sim 85^\circ C$, $T_J = -40 \sim 125^\circ C$	2.7	-	6	V
I_{DD1}	Input DC Bias Current	$V_{FB} = 1.3V$, no switching	70	100	130	μA
I_{DD2}		$FB = GND$, switching	-	1	2	mA
I_{SD}		$EN = GND$	-	-	1	μA
UNDER-VOLTAGE LOCKOUT						
	UVLO Threshold Voltage	V_{IN} Rising	2.0	2.2	2.4	V
	UVLO Hysteresis Voltage		50	100	150	mV
REFERENCE AND OUTPUT VOLTAGES						
V_{REF}	Regulated Feedback Voltage	$T_A = 25^\circ C$	237	250	263	mV
		$T_A = -40 \sim 85^\circ C$ ($T_J = -40 \sim 125^\circ C$)	230	-	270	
I_{FB}	FB Input Current		-50	-	50	nA
INTERNAL POWER SWITCH						
F_{SW}	Switching Frequency	$FB=GND$	0.8	1.0	1.2	MHz
R_{ON}	Power Switch On Resistance		-	0.6	-	
I_{LIM}	Power Switch Current-Limit		0.7	0.9	1.2	A
	LX Leakage Current	$V_{EN}=0V$, $V_{LX}=0V$ or $5V$, $V_{IN} = 5V$	-1	-	1	μA
D_{MAX}	LX Maximum Duty Cycle		92	95	98	%
OUTPUT OVER-VOLTAGE PROTECTION						
V_{OVP}	Over-Voltage Threshold	TD8202A	-	20	-	V
		TD8202B	-	28	-	
		TD8202C	-	35	-	
	OVP Hysteresis		-	3	-	V
	OVP Leakage Current	$V_{OVP} = 30V$, $EN=VIN$	-	-	50	μA
ENABLE AND SHUTDOWN						
V_{TEN}	EN Voltage Threshold	V_{EN} Rising	0.4	0.7	1	V
	EN Voltage Hysteresis		-	0.1	-	V
I_{LEN}	EN Leakage Current	$V_{EN}= 0\sim 5V$, $V_{IN} = 5V$	-1	-	1	μA
OVER-TEMPERATURE PROTECTION						
T_{OTP}	Over-Temperature Protection	T_J Rising	-	150	-	$^\circ C$
	Over-Temperature Protection Hysteresis		-	40	-	$^\circ C$

Typical Operating Characteristics

Efficiency vs. WLED Current

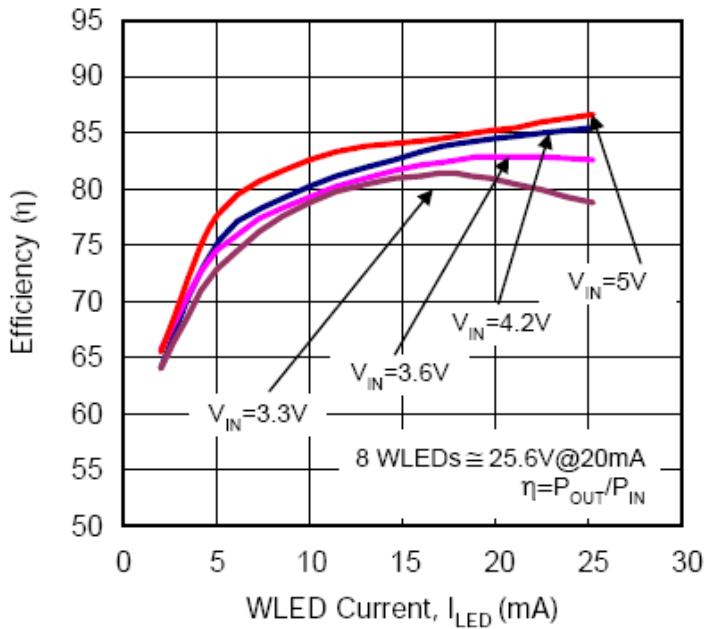

Efficiency vs. WLED Current

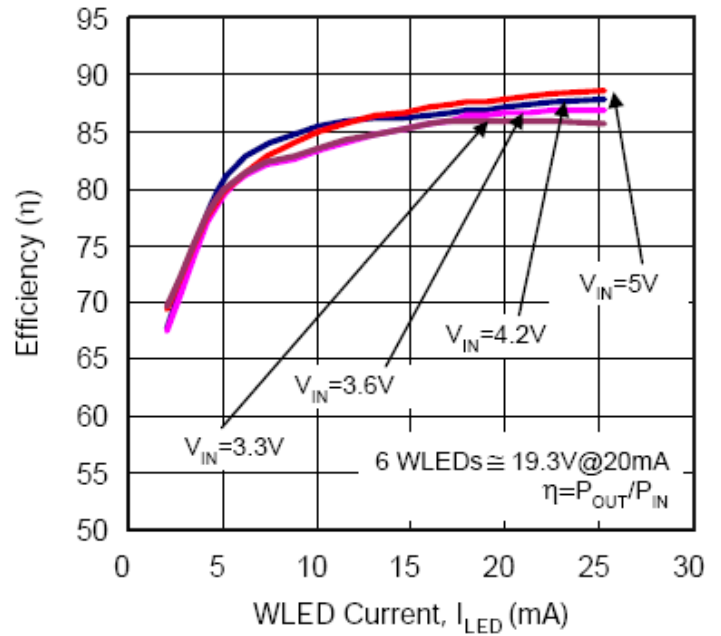

Efficiency vs. WLED Current

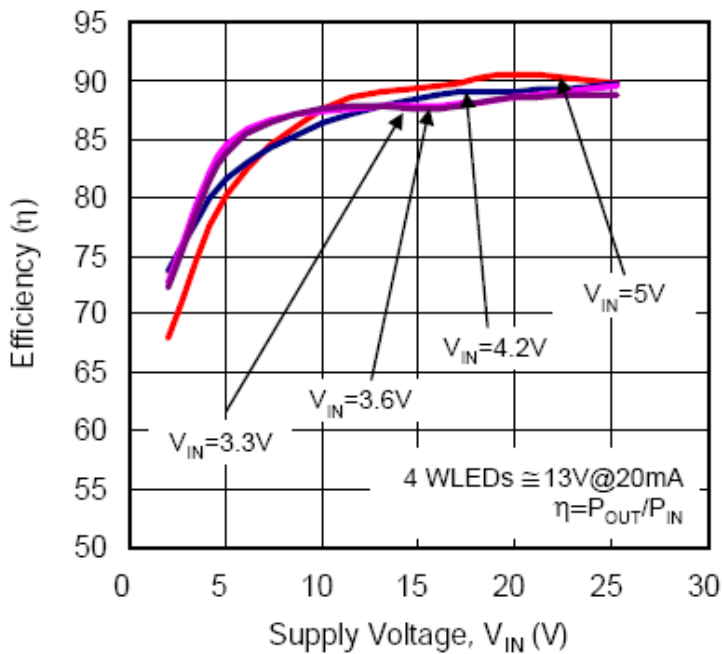

WLED Current vs. PWM Duty Cycle

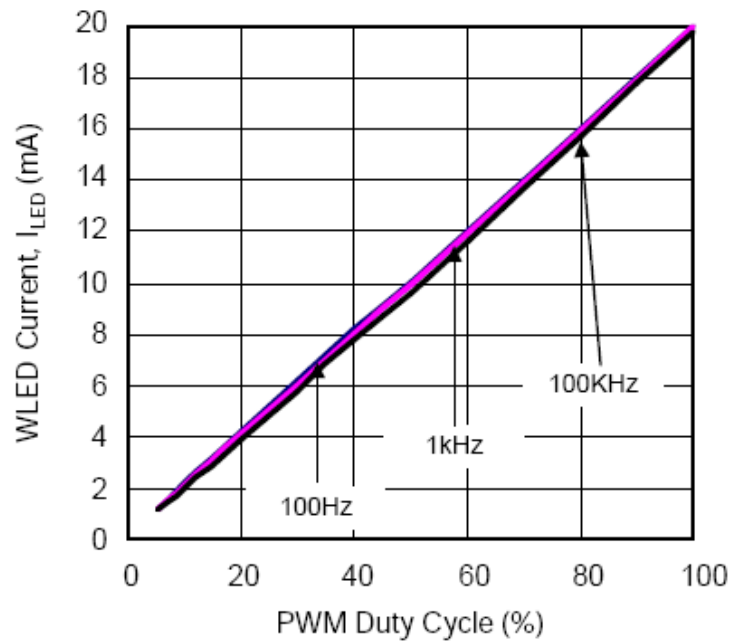

Typical Operating Characteristics(Cont.)

WLED Current vs. Supply Voltage

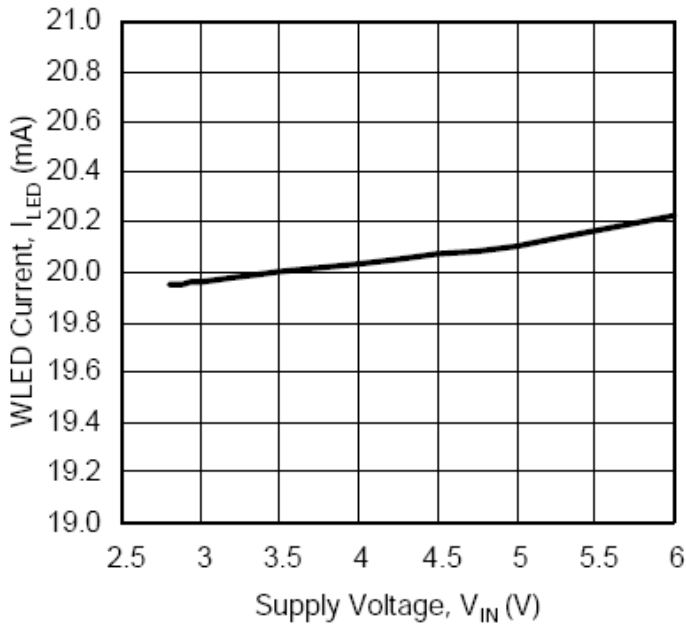

Switch ON Resistance vs. Supply Voltage

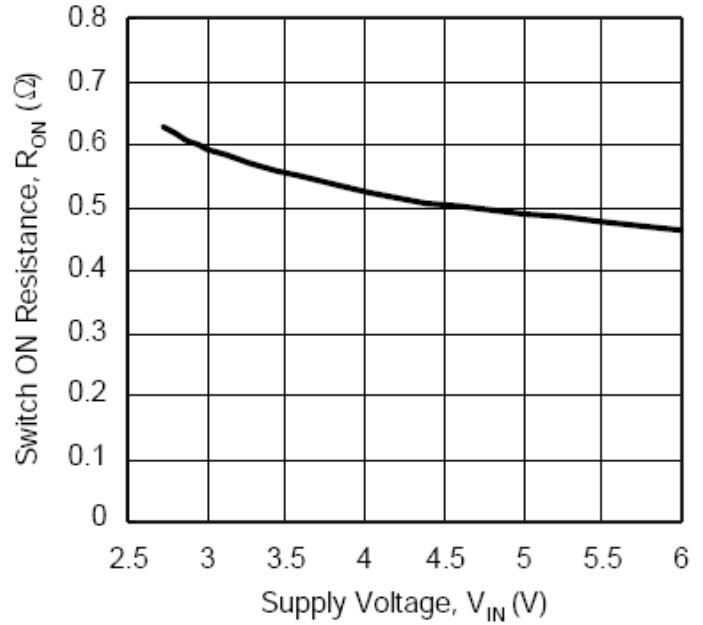

Switching Frequency vs. Supply Voltage

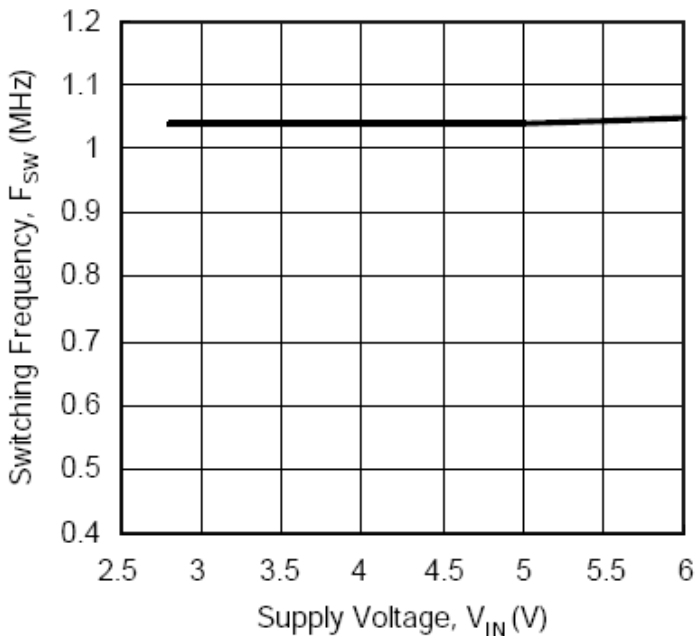

Maximum Duty Cycle vs. Supply Voltage

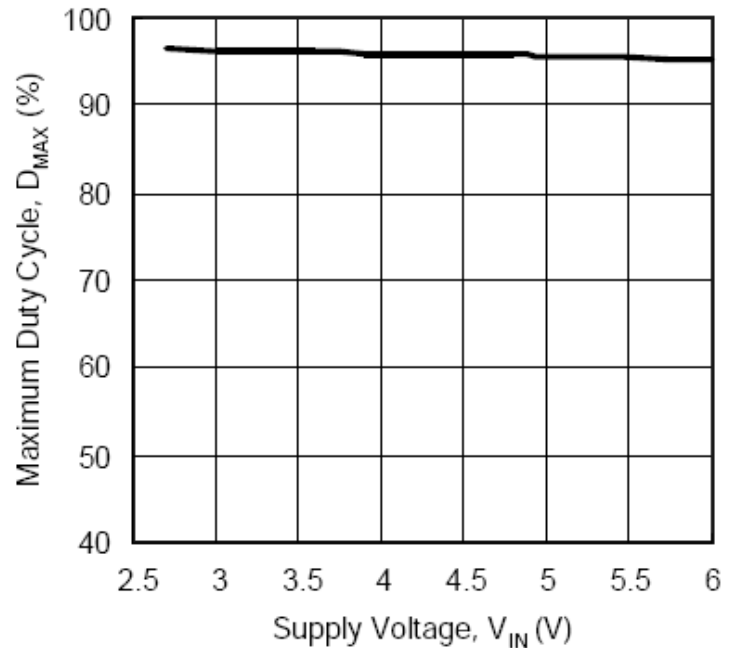

Operating Waveforms

Start-up

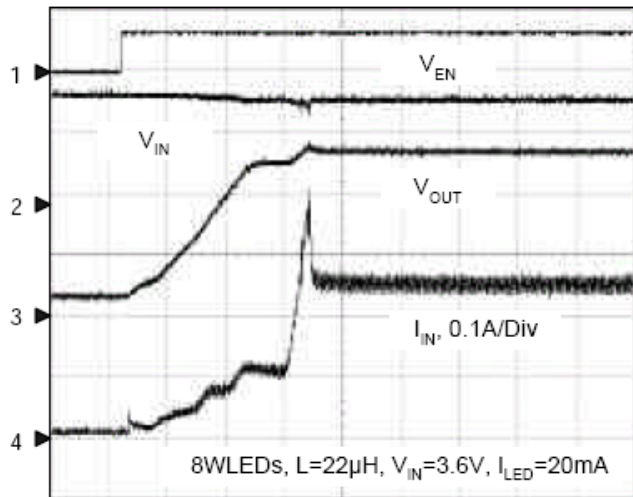

CH1: V_{EN} , 2V/Div, DC
 CH2: V_{IN} , 2V/Div, DC
 CH3: V_{OUT} , 10V/Div, DC
 CH4: I_L , 0.1A/Div, DC
 Time: 1ms/Div

Start-up

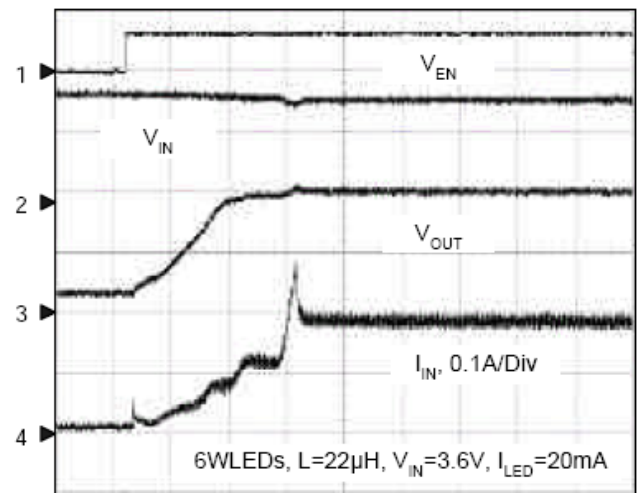

CH1: V_{EN} , 2V/Div, DC
 CH2: V_{IN} , 2V/Div, DC
 CH3: V_{OUT} , 10V/Div, DC
 CH4: I_L , 0.1A/Div, DC
 Time: 1ms/Div

Start-up

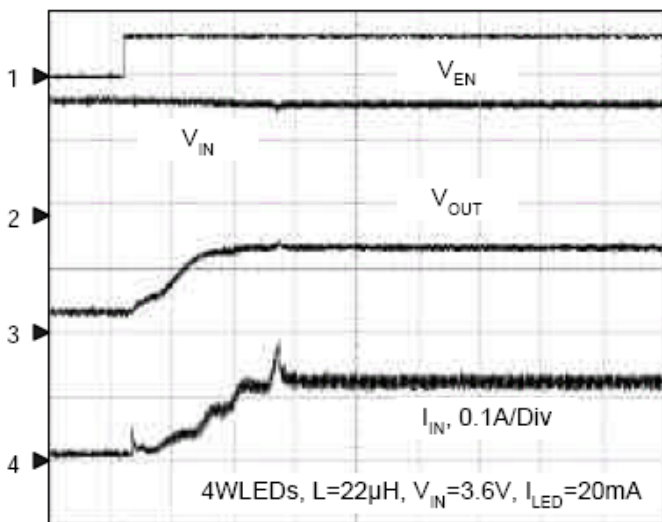

CH1: V_{EN} , 2V/Div, DC
 CH2: V_{IN} , 2V/Div, DC
 CH3: V_{OUT} , 10V/Div, DC
 CH4: I_L , 0.1A/Div, DC
 Time: 1ms/Div

Open-LED Protection

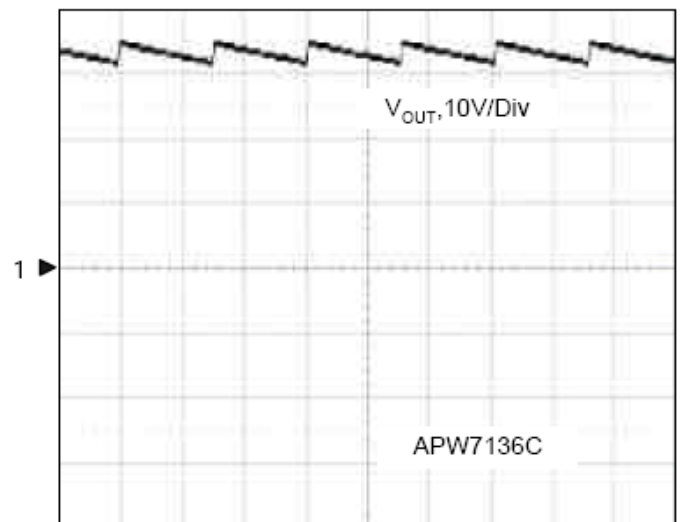

CH1: V_{OUT} , 10V/Div, DC
 Time: 20ms/Div

Operating Waveforms(Cont.)

Normal Operating Waveform

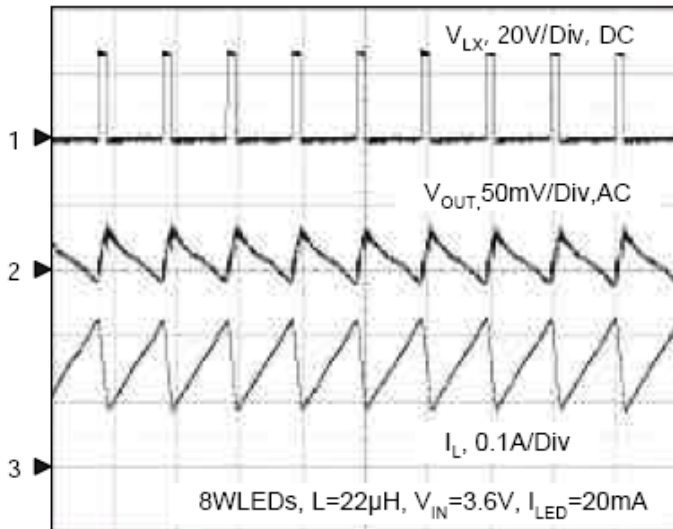

CH1: V_{LX} , 20V/Div, DC
CH2: V_{OUT} , 50mV/Div, AC
CH3: I_L , 0.1A/Div, DC
Time: 1 μs /Div

Typical Application Circuit

Typical 8 WLEDs Application

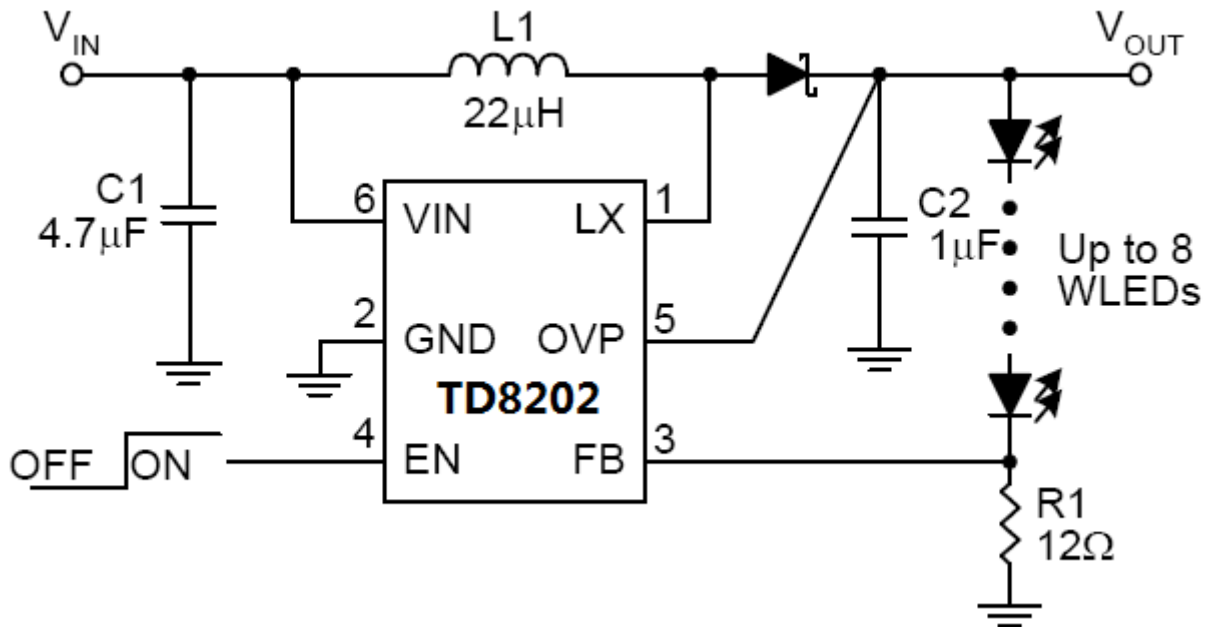

Brightness Control Using a PWM Signal Applies to EN

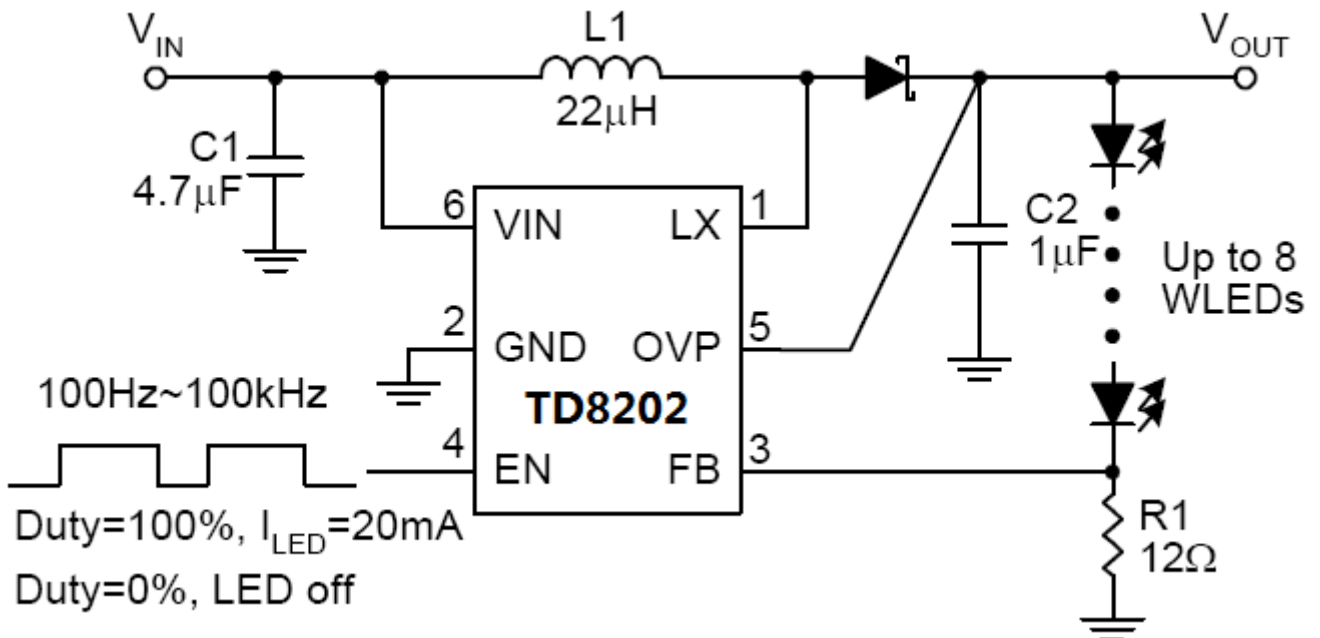

Typical Application Circuit(Cont.)

Brightness Control Using a Filtered PWM Signal

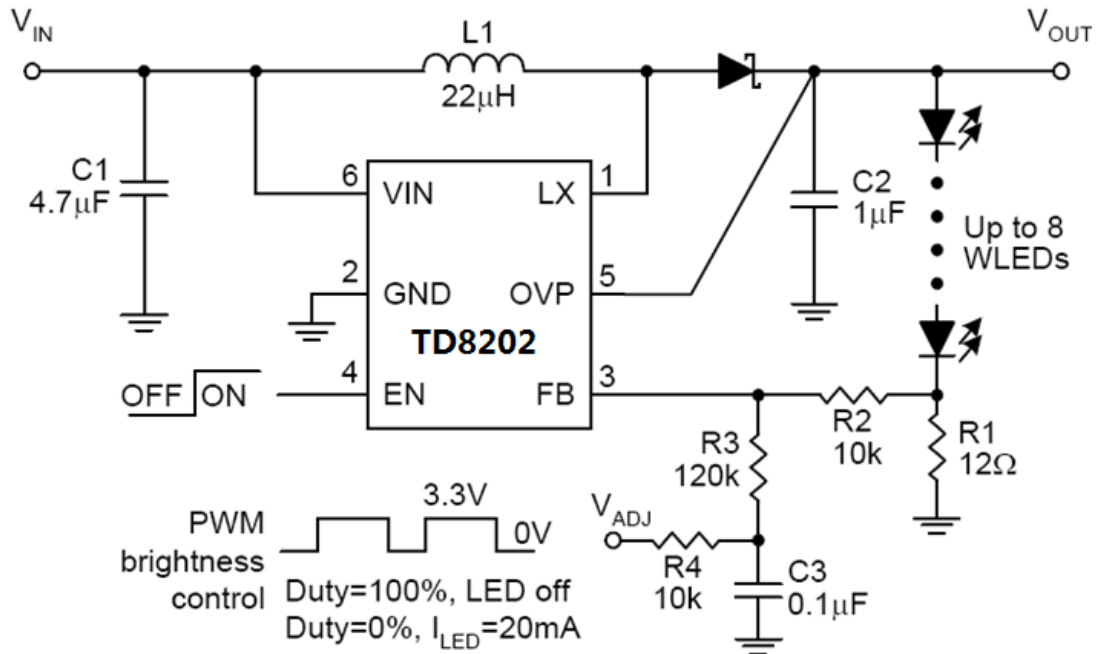

$$R2 = V_{REF} \cdot \frac{I_{LED,MAX} \cdot R3 + V_{ADJ,MIN} - I_{LED,MIN} \cdot R3 - V_{ADJ,MAX}}{V_{ADJ,MAX} \cdot I_{LED,MAX} + V_{REF} \cdot I_{LED,MIN} - V_{ADJ,MIN} \cdot I_{LED,MIN} - V_{REF} \cdot I_{LED,MAX}}$$

$$R1 = \frac{V_{REF} \cdot \left(1 + \frac{R2}{R3}\right) - \frac{R2}{R3} \cdot V_{ADJ,MIN}}{I_{LED,MAX}}$$

Circuit for Driving 27 WLEDs

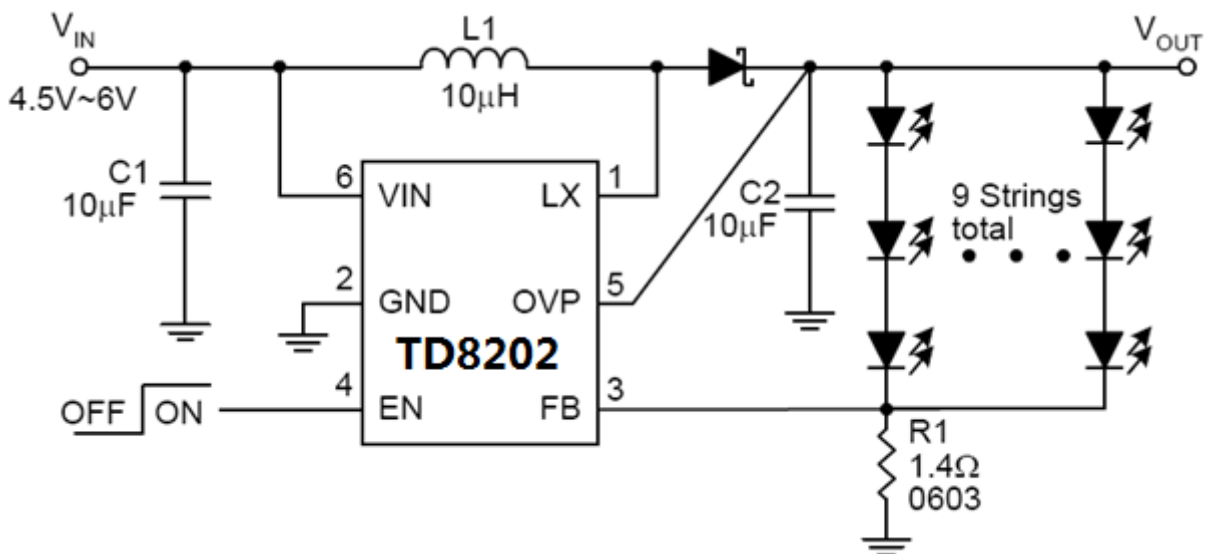

Function Description

Main Control Loop

The TD8202 is a constant frequency current-mode switching regulator. During normal operation, the internal N-channel power MOSFET is turned on each cycle when the oscillator sets an internal RS latch and turned off when an internal comparator (ICMP) resets the latch.

The peak inductor current at which ICMP resets the RS latch is controlled by the voltage on the COMP node, which is the output of the error amplifier (EAMP). An external resistive divider connected between V_{OUT} and ground allows the EAMP to receive an output feedback voltage V_{FB} at FB pin. When the load current increases, it causes a slightly decrease in V_{FB} relative to the 0.25V reference, which in turn causes the COMP voltage to increase until the average inductor current matches the new load current.

VIN Under-Voltage Lockout (UVLO)

The Under-Voltage Lockout (UVLO) circuit compares the input voltage at VIN with the UVLO threshold (2.2V, typical) to ensure the input voltage is high enough for reliable operation. The 100mV (typical) hysteresis prevents supply transients from causing a restart. Once the input voltage exceeds the UVLO rising threshold, start-up begins. When the input voltage falls below the UVLO falling threshold, the controller turns off the converter.

Soft-Start

The TD8202 has a built-in soft-start to control the Nchannel MOSFET current rise during start-up. During softstart, an internal ramp, connected to one of the inverting inputs, raises up to replace the output voltage of error amplifier until the ramp voltage reaches the V_{COMP} .

Current-Limit Protection

The TD8202 monitors the inductor current, flowing through the N-channel MOSFET, and limits the current peak at current-limit level to prevent loads and the TD8202 from damaging during overload conditions.

Over-Temperature Protection (OTP)

The over-temperature circuit limits the junction temperature of the TD8202. When the junction temperature exceeds 150°C, a thermal sensor turns off the power MOSFET, allowing the devices to cool. The thermal sensor allows the converters to start a soft-start process and regulate the output voltage again after the junction temperature cools by 40°C. The OTP is designed with a 40°C hysteresis to lower the average Junction Temperature (T_J) during continuous thermal overload conditions, increasing the lifetime of the device.

Enable/Shutdown

Driving EN to the ground places the TD8202 in shutdown mode. When in shutdown, the internal power MOSFET turns off, all internal circuitry shuts down and the quiescent supply current reduces to 1µA maximum. This pin also could be used as a digital input allowing brightness control using a PWM signal from 100Hz to 100kHz. The 0% duty cycle of PWM signal corresponds to zero LEDs current and 100% corresponds to full one.

Open-LED Protection

In driving LED applications, the feedback voltage on FB pin falls down if one of the LEDs, in series, is failed. Meanwhile, the converter unceasingly boosts the output voltage like a open-loop operation. Therefore, an overvoltage protection (OVP), monitoring the output voltage via OVP pin, is integrated into the chip to prevent the LX and the output voltages from exceeding their maximum voltage ratings. When the voltage on the OVP pin rises above the OVP threshold, the converter stops switching and prevents the output voltage from rising. The converter can work again when the OVP voltage falls below the falling of OVP voltage threshold.

Application Information

Input Capacitor Selection

The input capacitor (C_{IN}) reduces the ripple of the input current drawn from the input supply and reduces noise injection into the IC. The reflected ripple voltage will be smaller when an input capacitor with larger capacitance is used. For reliable operation, it is recommended to select the capacitor with maximum voltage rating at least 1.2 times of the maximum input voltage. The capacitors should be placed close to the VIN and the GND.

Inductor Selection

Selecting an inductor with low DC resistance reduces conduction losses and achieves high efficiency. The efficiency is moderated whilst using small chip inductor which operates with higher inductor core losses. Therefore, it is necessary to take further consideration while choosing an adequate inductor. Mainly, the inductor value determines the inductor ripple current: larger inductor value results in smaller inductor ripple current and lower conduction losses of the converter. However, larger inductor value generates slower load transient response. A reasonable design rule is to set the ripple current, ΔI_L , to be 30% to 50% of the maximum average inductor current, $I_{L(AVG)}$. The inductor value can be obtained as below,

$$L \geq \left(\frac{V_{IN}}{V_{OUT}} \right)^2 \times \frac{V_{OUT} - V_{IN}}{F_{SW} \cdot I_{OUT(MAX)}} \times \frac{\eta}{\left(\frac{\Delta I_L}{I_{L(AVG)}} \right)}$$

where

V_{IN} = input voltage

V_{OUT} = output voltage

F_{SW} = switching frequency in MHz

I_{OUT} = maximum output current in amp.

η = Efficiency

$\Delta I_L / I_{L(AVG)}$ = inductor ripple current/average current
(0.3 to 0.5, typical)

To avoid the saturation of the inductor, the inductor should be rated at least for the maximum input current of the converter plus the inductor ripple current. The maximum input current is calculated as below:

$$I_{IN(MAX)} = \frac{I_{OUT(MAX)} \times V_{OUT}}{V_{IN} \times \eta}$$

The peak inductor current is calculated as the following equation:

$$I_{PEAK} = I_{IN(MAX)} + \frac{1}{2} \cdot \frac{V_{IN} \cdot (V_{OUT} - V_{IN})}{V_{OUT} \cdot L \cdot F_{SW}}$$

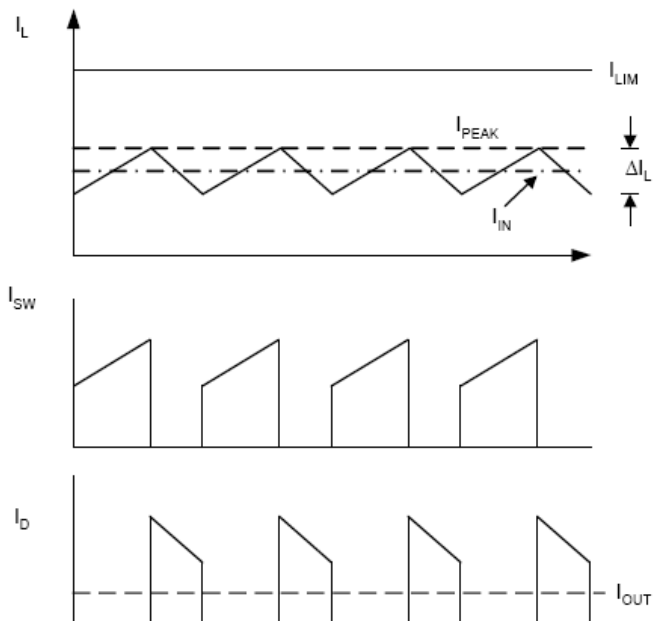
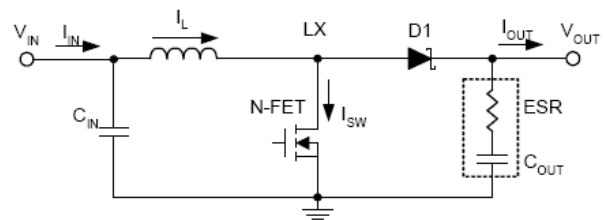

Output Capacitor Selection

The current-mode control scheme of the TD8202 allows the usage of tiny ceramic capacitors. The higher capacitor value provides good load transient response. Ceramic capacitors with low ESR values have the lowest output voltage ripple and are recommended. If required, tantalum capacitors may be used as well. The output ripple is the sum of the voltages across the ESR and the ideal output capacitor.

$$\Delta V_{OUT} = \Delta V_{ESR} + \Delta V_{COUT}$$

$$\Delta V_{ESR} \approx I_{PEAK} \times R_{ESR}$$

$$\Delta V_{ESR} \approx I_{PEAK} \times R_{ESR}$$

where I_{PEAK} is the peak inductor current.

Application Information(Cont.)

Output Capacitor Selection (Cont.)

For ceramic capacitor application, the output voltage ripple is dominated by the ΔV_{OUT} . When choosing the input and output ceramic capacitors, the X5R or X7R with their good temperature and voltage characteristics are recommended.

Diode Selection

To achieve the high efficiency, a Schottky diode must be used.

The current rating of the diode must meet the peak current rating of the converter.

Recommended Inductor Selection

Designato	Manufactur	Part Number	Inductance (μH)	Max DCR	Saturation	Dimensions
L1	GOTREND	GTSD32	22	0.592	0.52	3.85 x 3.85 x 1.8

Recommended Capacitor Selection

Designato	Manufactur	Part Number	Capacitance (μF)	TC Code	Rated Voltage	Case Size
C1	Murata	GRM188R60J475KE1	4.7	X5R	6.3	0603
C2	Murata	GRM21BR71H105KA1	1.0	X7R	50	0805

Recommended Diode Selection

Designat	Manufactur	Part Number	Maximum Average	Maximum Repetitive	Case Size
D1	Zowie	MSCD106	1.0	60	0805
D1	Zowie	MSCD104	1.0	40	0805

Layout Consideration

For all switching power supplies, the layout is an important step in the design; especially at high peak currents and switching frequencies. If the layout is not carefully done, the regulator might show noise problems and duty cycle jitter.

1. The input capacitor should be placed close to the VIN and the GND. Connecting the capacitor with VIN and GND pins by short and wide tracks without using any vias for filtering and minimizing the input voltage ripple.
2. The inductor should be placed as close as possible to the LX pin to minimize length of the copper tracks as well as the noise coupling into other circuits.
3. Since the feedback pin and network is a high impedance circuit, the feedback network should be routed away from the inductor. The feedback pin and feedback network should be shielded with a ground plane or track to minimize noise coupling into this circuit.
4. A star ground connection or ground plane minimizes ground shifts and noise is recommended.

Setting the LED Current

In figure 1, the converter regulates the voltage on FB pin, connected with the cathode of the lowest LED and the current-sense resistor R1, at 0.25V (typical). Therefore, the current (I_{LED}), flowing via the LEDs and the R1, is calculated by the following equation:

$$I_{\text{LED}} = 0.25V/R1$$

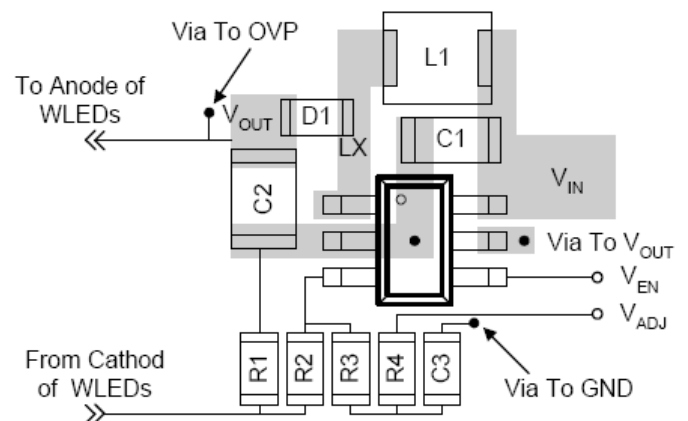

Optimized TD8202 Layout

Package Information

SOT23-6

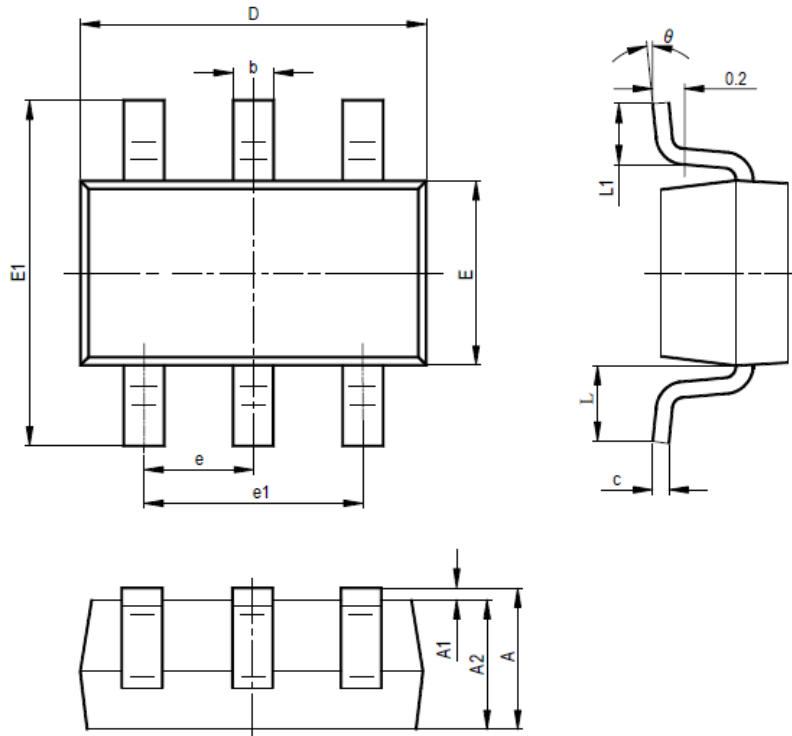

SYMBOL	MILLIMETERS		INCHES	
	MIN	MAX	MIN	MAX
A	1.050	1.250	0.041	0.049
A1	0.000	0.100	0.000	0.004
A2	1.050	1.150	0.041	0.045
b	0.300	0.400	0.012	0.016
c	0.100	0.200	0.004	0.008
D	2.820	3.020	0.111	0.119
E	1.500	1.700	0.059	0.067
E1	2.650	2.950	0.104	0.116
e	0.950TYP		0.037TYP	
e1	1.800	2.000	0.071	0.079
L	0.700REF		0.028REF	
L1	0.300	0.600	0.012	0.024
θ	0°	8°	0°	8°

Design Notes