

业务: 陈绍学 电话: 13760129706

General Description

QQ: 51413674

TD8218 is a compact, high efficiency, fixed frequency Boost DC/DC regulator. PFM mode for improved efficiency at low output power. The 1MHz high switching frequency allows smaller inductor and output capacitor, making the TD8218 ideally suited for small battery-powered applications and internal compensation reduce external component count and saves PCB space.

The TD8218 contains thermal shutdown function and over current protection circuit. Built-in soft-start circuitry prevents excessive inrush current during start-up.

The TD8218 is available in a Pb-free, SOP-8 package.

Features

- Boost DC/DC regulator with 3A constant load current
- With internal NMOS.
- Device quiescent current: 280uA.
- Internal soft_start and internal compensation.
- 6A maximum peak current limit.
- Switching frequency: 1MHz.
- Power save mode(PFM) for improved efficiency at low output power
- Over current protect and over temperature protection.
- Compact package: SOP-8.

Applications

- Cell Phone and Smart Phone
- PDA, PMP, MP3
- Digital Camera

Pin Configurations

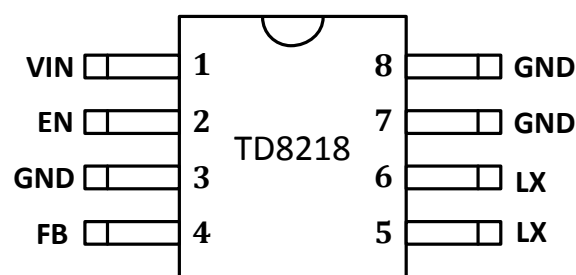
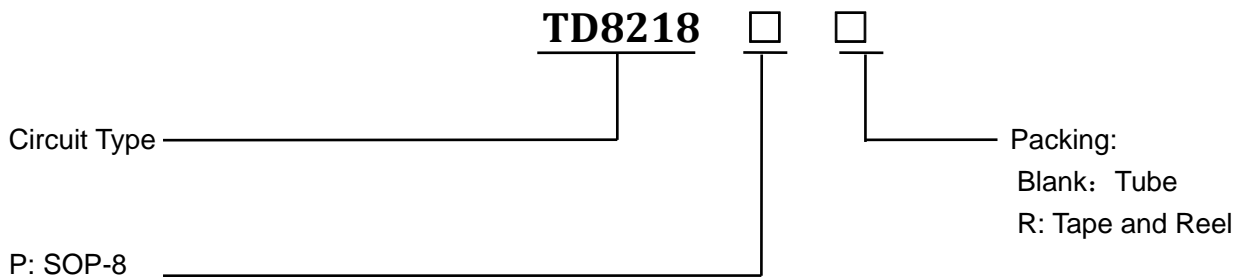

Figure1 Pin Configuration of TD8218(Top View)

Pin Description

Pin Number	Pin Name	Description
1	VDD	Power Input pin.
2	EN	Enable control. High to turn on the part. Don't leave it floated.
3	GND	GND
4	FB	Feedback pin. Connect a resistor R1 between VOUT and FB, and a resistor R2 between FB and GND to program the output voltage: $V_{OUT}=0.6V*(R1/R2+1)$
5	LX	Inductor node. Connect an inductor between VDD pin and LX pin.
6	LX	Inductor node. Connect an inductor between VDD pin and LX pin.
7	GND	GND
8	GND	GND

Ordering Information



Function Block

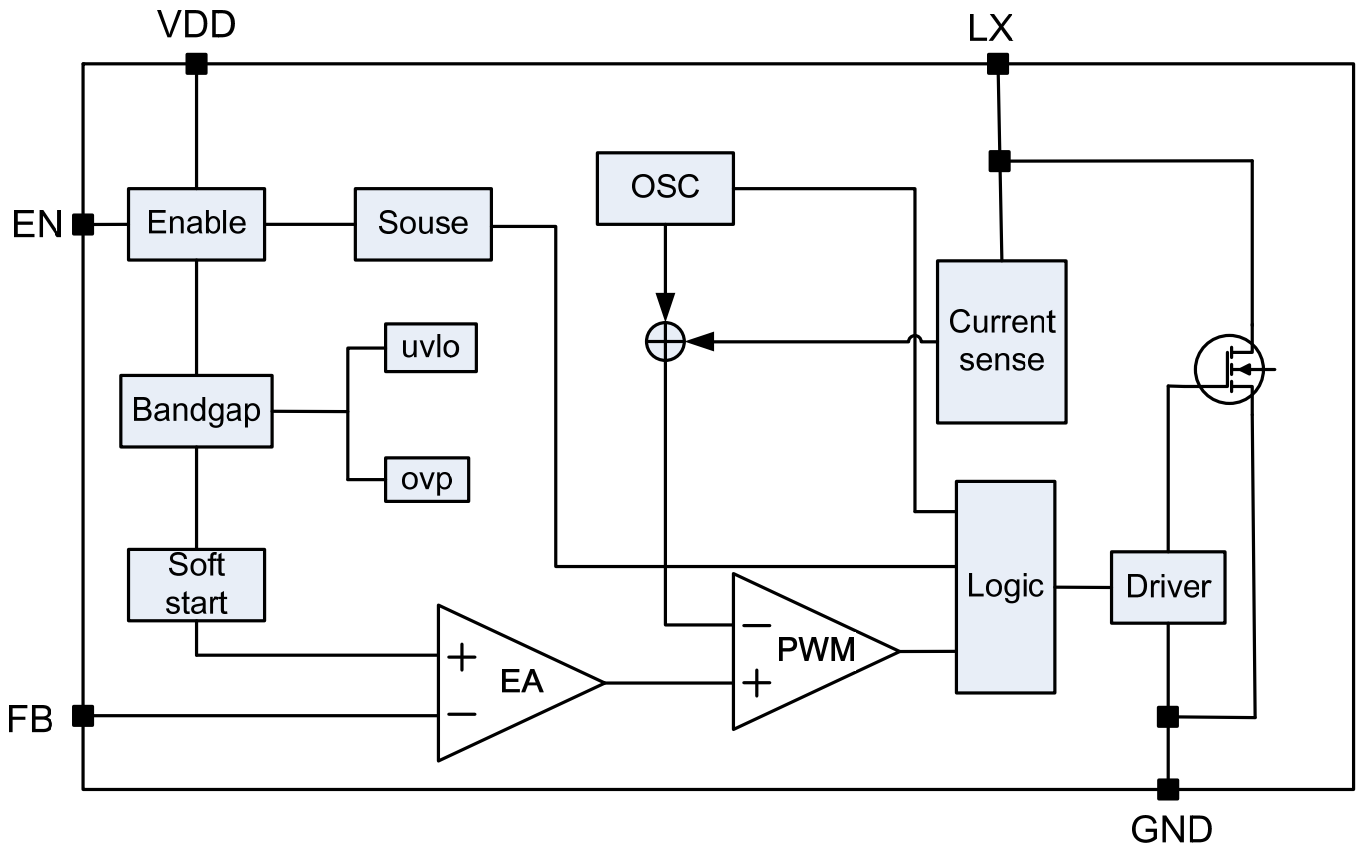

Figure 2 Function Block Diagram of TD8218

Absolute Maximum Ratings

EN, VDD, LX,-----	7V
FB-----	3.6V
SOP-8, θ_{JA} -----	90°C/W
SOP-8, θ_{JC} -----	45°C/W
Junction Temperature Range -----	125°C
Lead Temperature (Soldering, 10 sec.)-----	260°C
Storage Temperature Range -----	-65°C to 150°C

Recommended Operating Conditions

VDD pin-----	2.8V to 4.2V
FB-----	0V to 1V
Junction Temperature Range -----	-40°C to 125°C
Ambient Temperature Range -----	-40°C to 85°C

Electrical Characteristics

(VIN = 3.3V, VOUT=5V, IOUT=100mA, TA = 25°C unless otherwise specified)

Parameters	Symbol	Test Condition	Min.	Typ.	Max.	Unit
Input voltage range	VDD		2.8		4.2	V
Output Voltage	VOUT		3	5	6	V
Shutdown Current	ISD	VEN=0V,VOUT=5V		8.3		μA
Quiescent Current	IQ	VEN=2V,VFB=1V		280		μA
OTP						
Thermal Shutdown		3V<VOUT<5V	140	164	170	°C
Hysteresis				32.5		°C
SUOSC						
Duty cycle				37.5%		
UVLO						
UVLO high threshold voltage				2.496		V
UVLO low threshold voltage				2.243		V
Hysteresis				0.245		V
OVP						
OVP threshold voltage				6.40		V
Hysteresis				0.33		V
OSC						
Oscillator frequency	fosc		0.8	1	1.2	MHz
Maximum duty cycle	Dmax			86.2		%

Soft Start						
steps				8		
Time				64		μS
Current Sense						
Current sense transconductance	Gcs			8.8		A/V
Current limit				6		A
Parameters	Symbol	Test Condition	Min.	Typ.	Max.	Unit
EA						
Feedback voltage	V _{FB}		0.587	0.603	0.613	
EA voltage gain	A _v			70		db
EA transconductance	G _m			12.8		μA/V
Driver						
Rising edge time				37.6		ns
Falling edge time				34		ns
Enable						
EN open voltage		0V to 2V		725		mV
En shut voltage		2V to 0V		708		mV
Hysteresis				17		mV

Typical Application Circuit

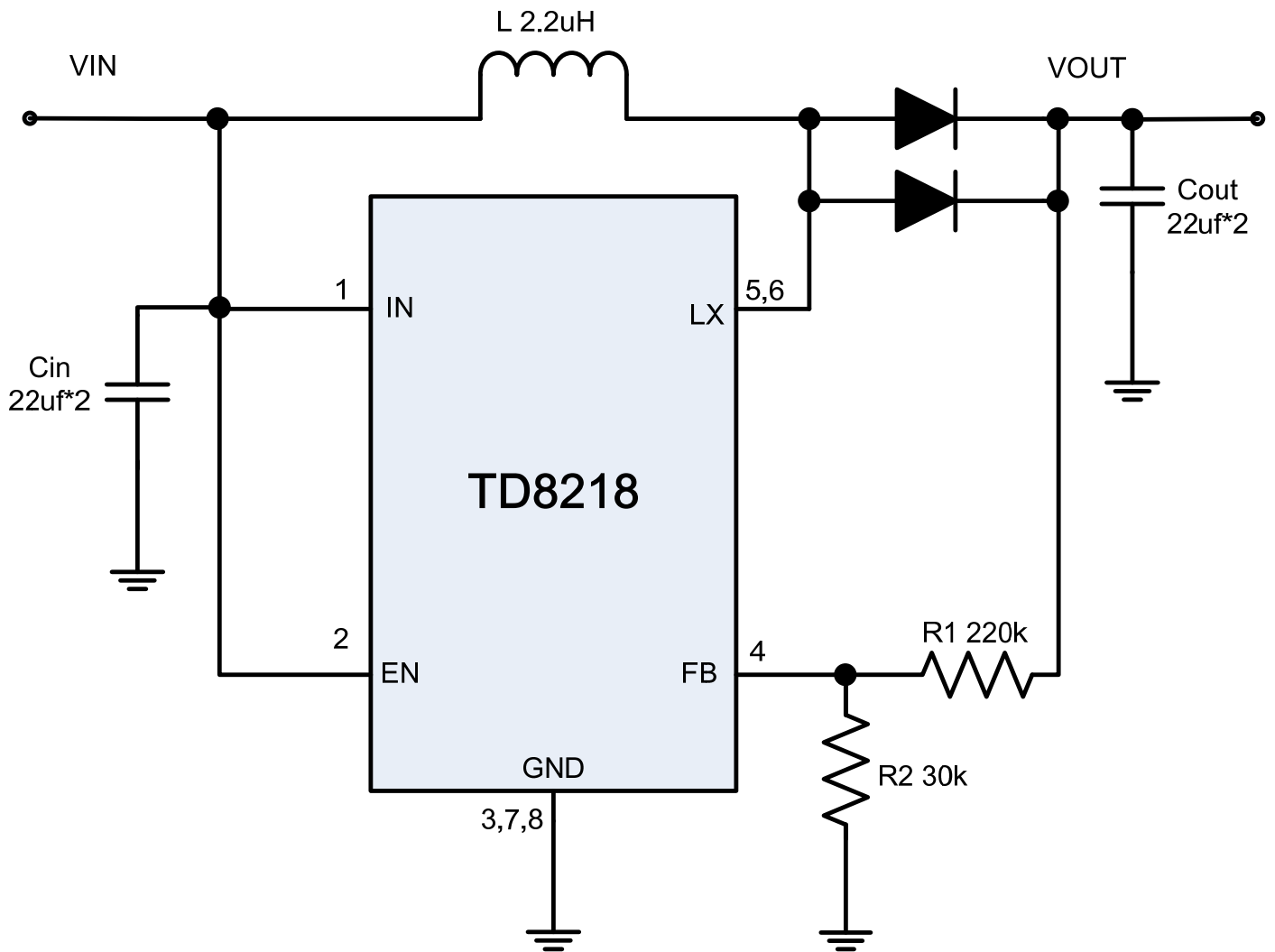

Function Description

The TD8218 uses a 1MHz fixed-frequency, current-mode regulation architecture to regulate the output voltage. It senses the output voltage through an external resistive voltage divider and compares that to the internal 0.6V reference to generate the error voltage, which is used to control the duty cycle and regulates the Vout to the set value.

Soft-Start

The TD8218 includes a soft-start timer that steps up output voltage to prevent excessive current at the input. This will prevent premature termination of the source voltage at startup due to inrush current, and also force the input current to rise slowly to regulate the output voltage during soft-start.

UVLO

The TD8218 has a UVLO (under voltage lock out) circuit for avoiding IC malfunctions due to power supply voltage drops. The TD8218 stops switching operation upon UVLO detection and retains the external transistor in the off state. Once entering the UVLO detection status, the soft-start function is reset.

Enable

Pulling the EN pin low will shut down the device. During the shutdown mode, the TD8218 shutdown current drops to lower than 10uA, Driving the EN pin high will turn on the IC again.

Application Information

Setting the Output Voltage

Set the output voltage by selecting the resistive voltage divider ratio. The voltage divider drops the output voltage to the 0.6V feedback voltage. Use 20kΩ resistor for R2 of the voltage divider. Determine the resistor R1 by the equation: determining the inductance is to allow the peak-to-peak ripple current to be approximately 30%-50% of the maximum

$$R1 = R2 * \left(\frac{V_{out}}{V_{fb}} - 1 \right)$$

Where Vout is the output voltage; Vfb is the 0.6V feedback voltage. And when Vout is 5.0V, R1 is 147kΩ.

Selecting the Input Capacitor

An input capacitor is required to supply the AC ripple current to the inductor, while limiting noise at the input source. Multi-layer ceramic capacitors are the best choice as they have extremely low ESR and are available in small footprints. Use an input capacitor value of 10μF or greater. This capacitor must be placed physically close to the device.

Selecting the Output Capacitor

The output capacitor is selected to handle the output ripple noise requirements. Both steady state ripple and transient requirements must be taken into consideration. A single 22μF ceramic capacitor usually provides sufficient output capacitance for most applications. Larger values up to 44μF may be used to obtain extremely low output voltage ripple and improve transient response. The impedance of the ceramic capacitor at the switching frequency is dominated by the capacitance, therefore the output voltage ripple is mostly independent of the ESR. The output voltage ripple Vripple is calculated as:

$$V_{ripple} = \frac{I_{load}(V_{out} - V_{in})}{V_{out} * C_{out} * f_{sw}}$$

Where Vin is the input voltage, Iload is the load current, Cout is the output capacitor and fsw is the 1MHz switching frequency.

Selecting the Inductor

There are several considerations in choosing this inductor.

1) The inductor is required to force the output voltage higher while being driven by the lower input voltage. A good rule for

input current. Calculate the inductance value L using the equation:

$$L = \left(\frac{V_{in}}{V_{out}} \right)^2 \frac{\eta * (V_{out} - V_{in})}{f_{sw} * (30\% \sim 50\%) * I_{max}}$$

Where fsw is the switching frequency, I_{max} is the maximum load current and η is efficiency. For the TD8218, typically 2.2μH is recommended for most applications.

2) The saturation current rating of the inductor must be selected to be greater than the peak inductor current under full load conditions.

$$I_{sat, min} > \left(\frac{V_{out}}{V_{in}} \right) * I_{max} + \frac{V_{in} * (V_{out} - V_{in})}{2 * L * f_{sw} * V_{out}}$$

3) The DCR of the inductor and the core loss at the switching frequency must be low enough to achieve the desired efficiency requirement. It is desirable to choose an inductor with DCR < 50mΩ to achieve a good overall efficiency.

Selecting Diode

Schottky diode is a good choice for high efficiency operation because of its low forward voltage drop and fast reverse recovery. The current rating of the diode must meet following:

$$I_d \approx \sqrt{I_{out} * I_{peak}}$$

The schottky diode reverse breakdown voltage should be larger than the output voltage.

Package Information

SOP-8 Package Outline Dimensions

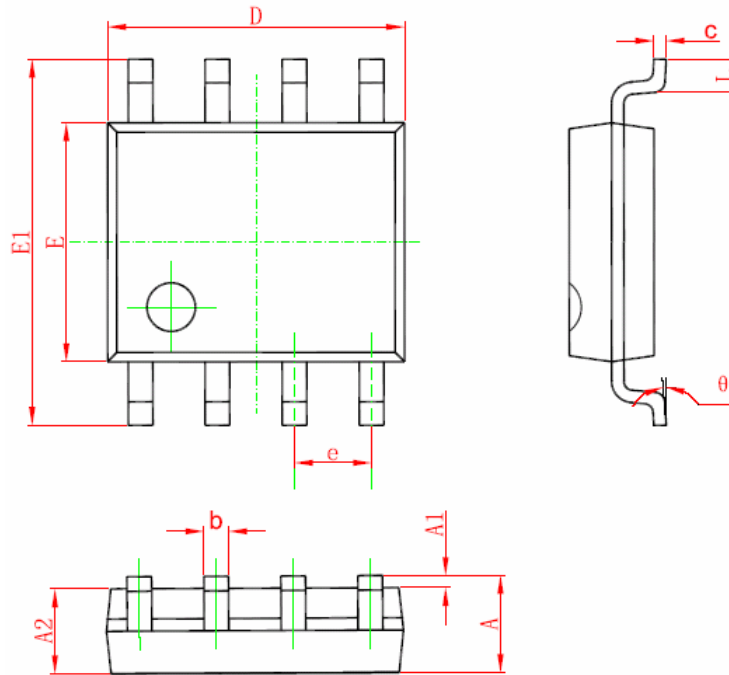

Symbol	Dimensions In Millimeters		Dimensions In Inches	
	Min	Max	Min	Max
A	1.350	1.750	0.053	0.069
A1	0.100	0.250	0.004	0.010
A2	1.350	1.550	0.053	0.061
b	0.330	0.510	0.013	0.020
c	0.170	0.250	0.006	0.010
D	4.700	5.100	0.185	0.200
E	3.800	4.000	0.150	0.157
E1	5.800	6.200	0.228	0.244
e	1.270 (BSC)		0.050 (BSC)	
L	0.400	1.270	0.016	0.050
θ	0°	8°	0°	8°

Design Notes