

General Description

The TD9721 is a stereo, differential input, single supply, and cap-free line driver, which is available in SOP-14 and TSSOP-14 packages.

The TD9721 is ground-reference output, and doesn't need the output capacitors for DC blocking. The advantages of eliminating the output capacitor are saving the cost, eliminating component height, and improving the low frequency response.

The external gain setting is recommended using from $\pm 1V/V$ to $\pm 10V/V$. High PSRR provides increased immunity to noise and RF rectification. TD9721 has shutdown and under-voltage detector function for Depop solution.

The TD9721 is capable of driving $2.1V_{rms}$ at 3.3V into $2.5k\Omega$ load, and provides short-circuit and thermal protection.

Features

- Operating Voltage: 3V~3.6V
- Differential Input
- Ground Reference Output
 - No Output Capacitor Required (for DC Blocking)
 - Save the PCB Space
 - Reduce the BOM Costs
- Improve the Low Frequency Response
 - Low Noise and THD+N
 - SNR > 108dB
 - Noise < $8\mu V_{rms}$
 - THD+N < 0.02% at 20Hz~20kHz
 - Output Voltage Swing Can Reach $2.1V_{rms}/\text{Ch}$ into $2.5k\Omega$ at $V_{DD}=3.3V$
 - High PSRR: 80dB at 217Hz
 - Fast Start-up Time: 500us
 - Integrate the De-Pop Circuitry
 - Thermal and Short-Circuit Protection
 - Surface-Mount Packaging
 - SOP-14
 - TSSOP-14
 - Lead Free and Green Devices Available (RoHS Compliant)

Applications

- Set-Top Boxes
- CD/DVD Players
- LCD TVs
- HTIBs (Home Theater in Box)

Pin Configurations

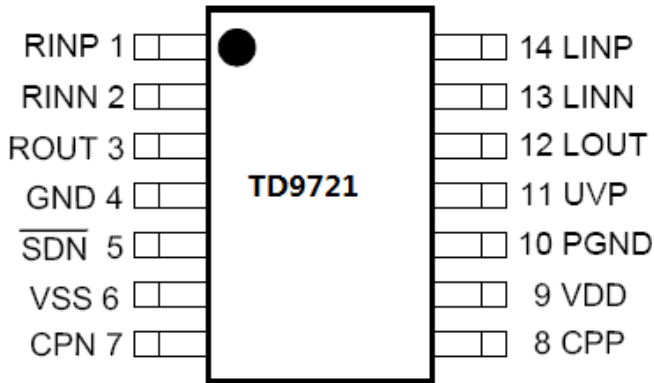

TSSOP-14
(Top View)

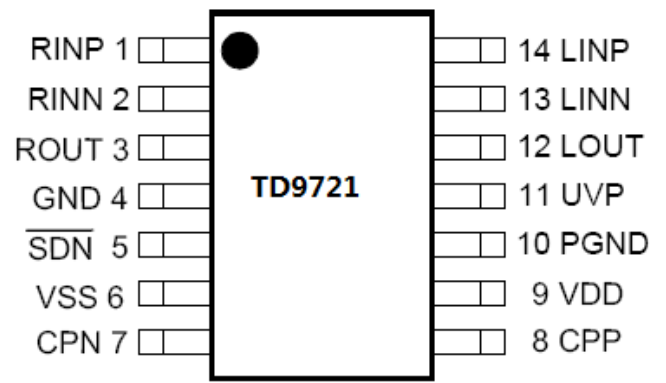

SOP-14
(Top View)

Pin Description

NO.	NAME	I/O/P	FUNCTION
1	RINP	I	Right channel non-inverting input.
2	RINN	I	Right channel inverting input.
3	ROUT	O	Right channel output.
4	GND	P	Signal ground.
5	SDN	I	Shutdown mod control input signal, pull low for shutdown headphone driver. This pin should be connect a 100Ω Protection Resistor.
6	VSS	P	Headphone driver negative power supply.
7	CPN	I/O	Charge pump flying capacitor negative connection.
8	CPP	I/O	Charge pump flying capacitor positive connection.
9	VDD	P	Supply voltage input.
10	PGND	P	Power ground.
11	UVP	I	Under voltage protection input. Floating or Pull "H" to disable this function.
12	LOUT	O	Left channel output.
13	LINN	I	Left channel inverting input.
14	LINP	I	Left channel non-inverting input.

Ordering Information

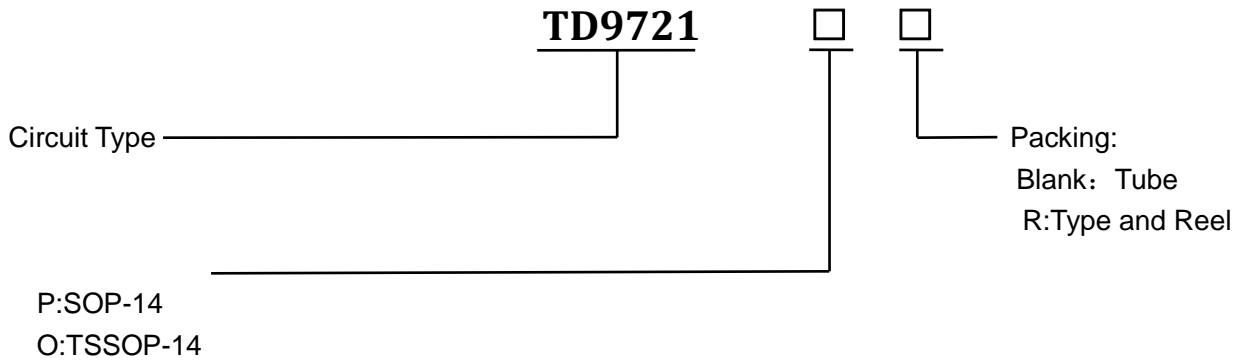

Functional Block Diagram

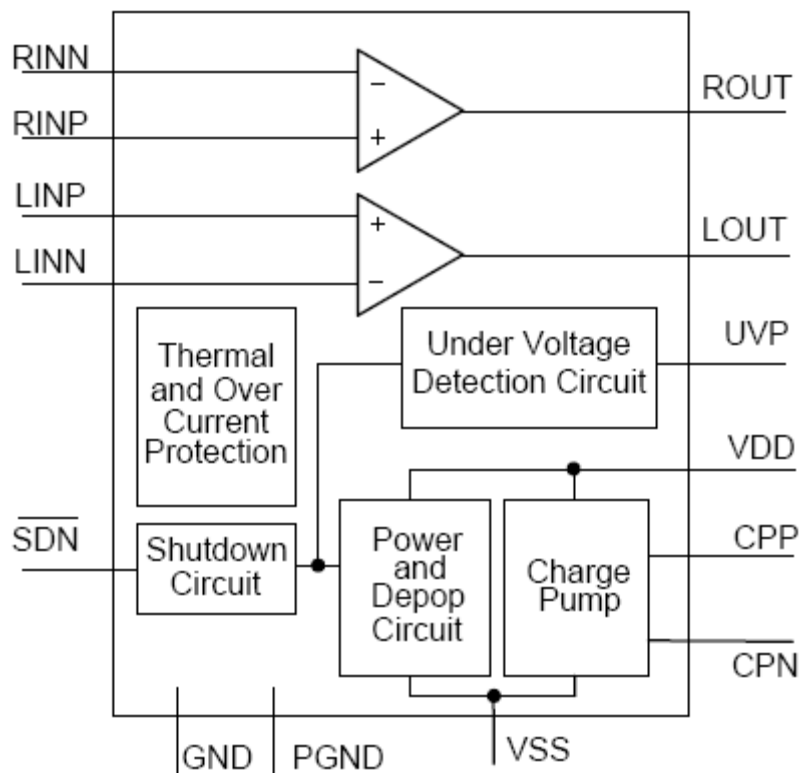

Absolute Maximum Ratings

Symbol	Parameter	Rating	Unit
V_{PGND_GND}	PGND to GND Voltage	-0.3 to 0.3	V
V_{DD}	Supply Voltage (VDD to GND and PGND)	-0.3 to 4	
V_{SDN}	Input Voltage (\overline{SDN} to GND)	$V_{GND}-0.3$ to $V_{DD}+0.3$	
V_{SS}	VSS to GND and PGND Voltage	-6 to 0.3	
V_{OUT}	ROUT and LOUT to GND Voltage	$V_{SS}-0.3$ to $V_{DD}+0.3$	
V_{CPP}	CPP to PGND Voltage	$V_{PGND}-0.3$ to $V_{DD}+0.3$	
V_{CPN}	CPN to PGND Voltage	$V_{SS}-0.3$ to $V_{PGND}+0.3$	
T_J	Maximum Junction Temperature	150	°C
T_{STG}	Storage Temperature Range	-65 to +150	
T_{SDR}	Maximum Soldering Temperature Range, 10 Seconds	260	
P_D	Power Dissipation	Internally Limited	W

Note1: Stresses beyond those listed under "absolute maximum ratings" may cause permanent damage to the device. These are stress ratings only and functional operation of the device at these or any other conditions beyond those indicated under "recommended operating conditions" is not implied. Exposure to absolute maximum rating conditions for extended periods may affect device reliability.

Recommended Operating Conditions

Symbol	Parameter	Range		Unit
		Min.	Max.	
V_{DD}	Supply Voltage	3	3.6	V
V_{IH}	High Level Threshold Voltage	SDN	1.0	
V_{IL}	Low Level Threshold Voltage	\overline{SDN}	-	
T_A	Operating Ambient Temperature Range	-40	85	°C
T_J	Operating Junction Temperature Range	-40	125	°C
R_L	Load Resistance	600	100k	Ω

Thermal Characteristics

Symbol	Parameter	Typical Value	Unit
θ_{JA}	Thermal Resistance - Junction to Ambient ^(Note 2)		°C/W
	TSSOP-14 SOP-14	120 120	

Note 2: Please refer to "Thermal Pad Consideration". 2 layered 5 in2 printed circuit boards with 2oz trace and copper through several thermal vias. The thermal pad is soldered on the PCB.

Electrical Characteristics

V_{DD}=3.3V, V_{GND}=V_{PGND}=0V, V_{SDN}=V_{DD}, C_{CPF}=C_{CPO}=1μF, C_i=1μF, R_L=2.5kΩ, T_A=25°C, R_i=10kΩ, R_f=20kΩ (unless otherwise noted)

Symbol	Parameter	Test Conditions				Unit
			Min.	Typ.	Max.	
I _{DD}	V _{DD} Supply Current		-	10	15	mA
I _{SD}	V _{DD} Shutdown Current	V _{SDN} =0V	-	1	5	μA
I _i	Input Current	SDN	-	0.1	-	μA
CHARGE PUMP						
f _{OSC}	Switching Frequency		400	500	600	kHz
R _{eq}	Equivalent Resistance		-	21	25	Ω
DRIVERS						
A _{VO}	Open Loop Voltage Gain		80	100	-	dB
GW	Unity Gain Bandwidth		8	10	-	MHz
V _{SR}	Slew Rate		-	4.5	-	V/μs
V _{OS}	Output Offset Voltage	V _{DD} =3.0V to 3.6V, R _L = 2.5kΩ	-5	-	5	mV
V _N	Output Noise	R _i =10kΩ, R _f =10kΩ	-	8	15	μV _{rms}
T _{start-up}	Start-up Time		-	500	-	μs
PSRR	Power Supply Rejection Ratio	V _{DD} =3.0V to 3.6V, V _{rr} =200mV _{rms} f _{in} = 217Hz f _{in} = 1kHz f _{in} = 20kHz	-	-80 -80 -50	-60 -60 -45	dB
C _L	Maximum Capacitive Load		-	220	-	pF
V _{ESD}	ESD Protection	OUTR, OUTL	-	8	-	kV
V _O	Output Voltage (Stereo, In Phase)	THD+N=1%, f _{in} =1kHz R _L =2.5kΩ R _L =100kΩ	2.0 -	2.1 2.3	-	V
P _O	Output Power (Stereo, In Phase)	THD+N=1%, f _{in} =1kHz R _L =32Ω	-	20	-	mW
THD+N	Total Harmonic Distortion Plus Noise	V _O =2V _{rms} , R _L =2.5kΩ f _{in} =20Hz f _{in} =1kHz f _{in} =20kHz	-	0.02 0.001 0.02	- - -	%
		P _O =20mW, R _L =32Ω f _{in} =1kHz	-	0.04	-	
Crosstalk	Channel Separation	V _O =2V _{rms} , R _L =2.5kΩ f _{in} =20Hz f _{in} =1kHz f _{in} =20kHz	-	100 100 90	-	dB
S/N	Signal to Noise Ratio	V _O =2V _{rms} , R _L =2.5kΩ, R _i =10kΩ, R _f =10kΩ, With A-weighting Filter	-	108	102	dB
T _{SD}	Thermal Shutdown Protection Temperature		-	150	-	°C
UVP FUNCTION						
V _{UVP}	External Under Voltage Detection		-	1.25	-	V
I _{HYS}	External Under Voltage Detection Hysteresis Current		-	5.0	-	μA

Typical Operating Characteristics

THD+N vs. Output Power

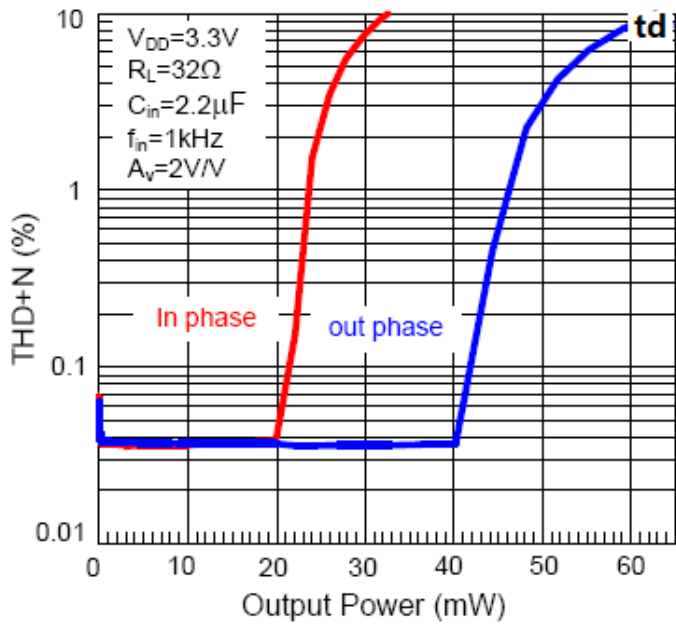

THD+N vs. Output Voltage

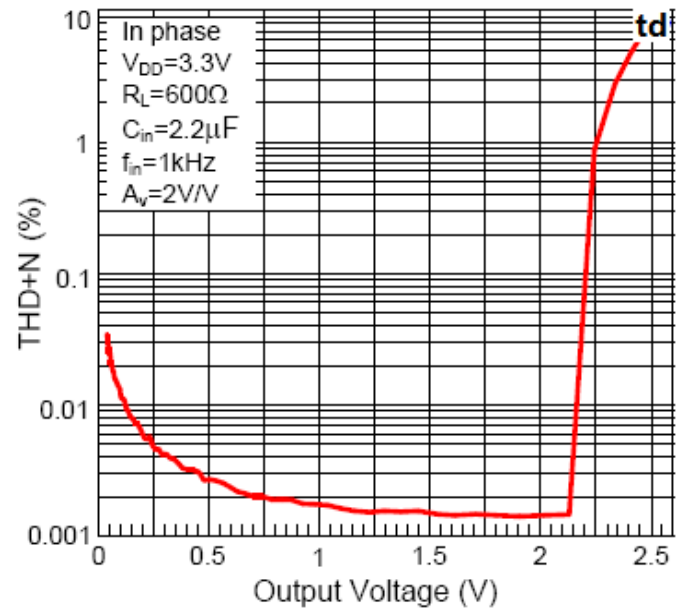

THD+N vs. Output Voltage

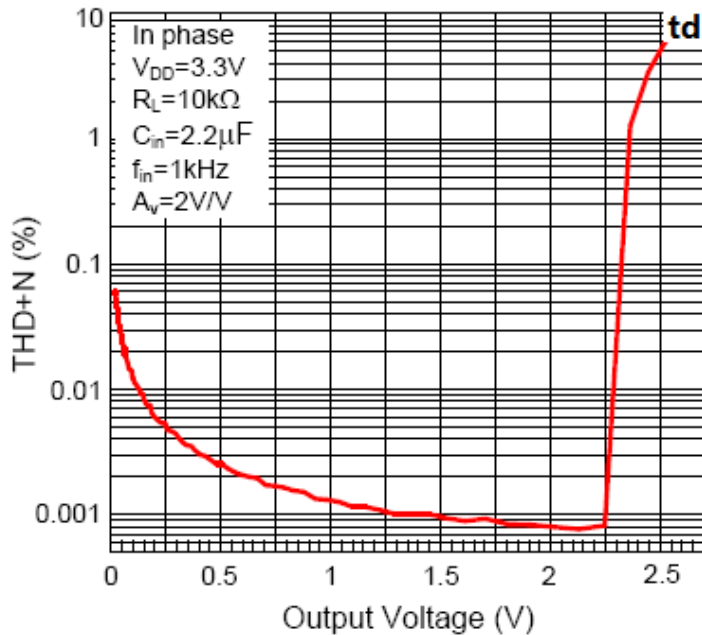

THD+N vs. Output Voltage

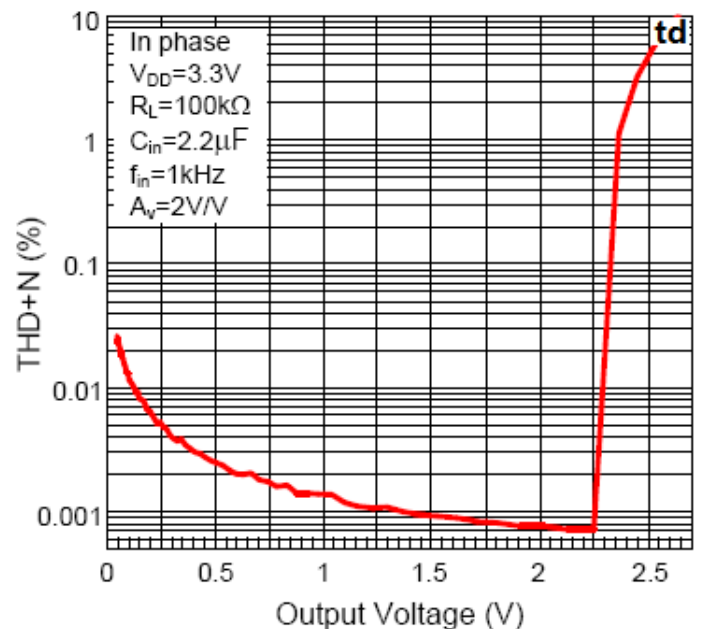

Typical Operating Characteristics(Cont.)

THD+N vs. Frequency

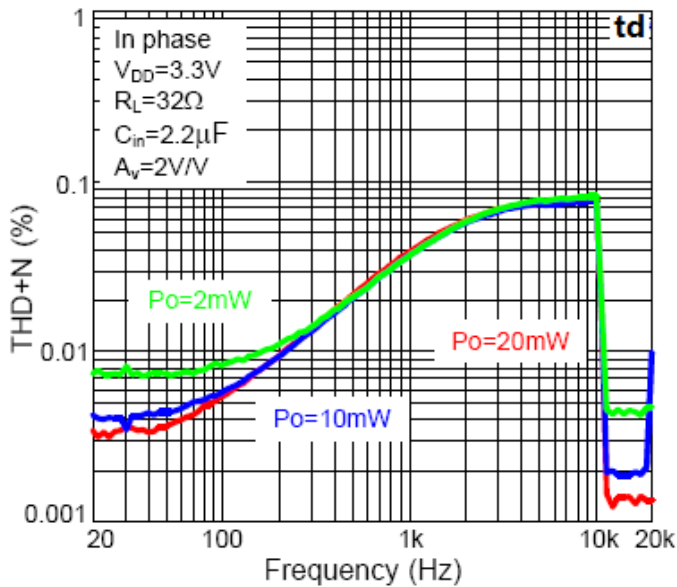

THD+N vs. Frequency

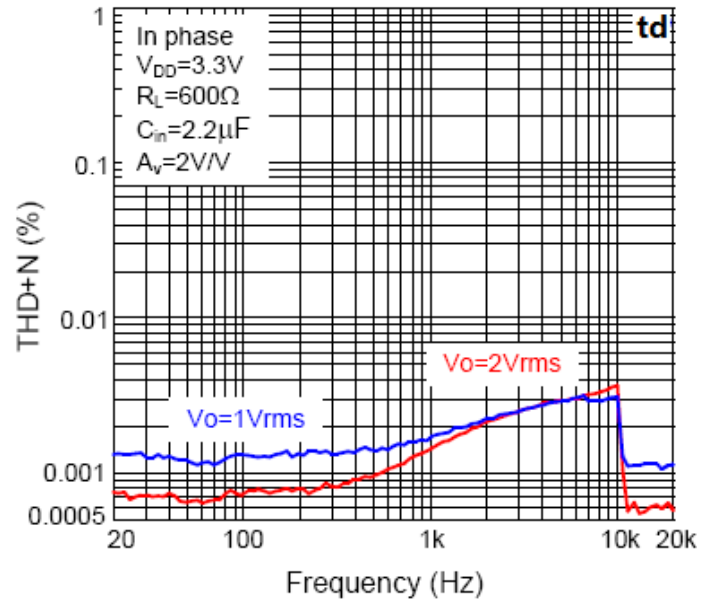

THD+N vs. Frequency

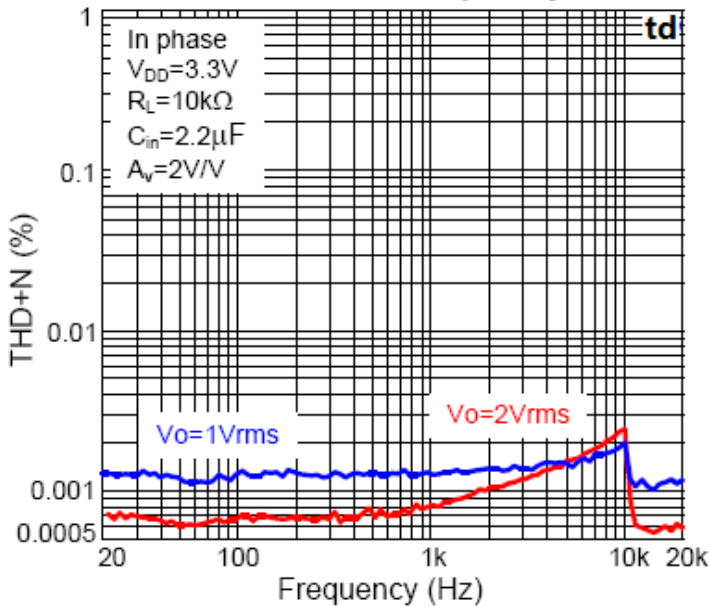

THD+N vs. Frequency

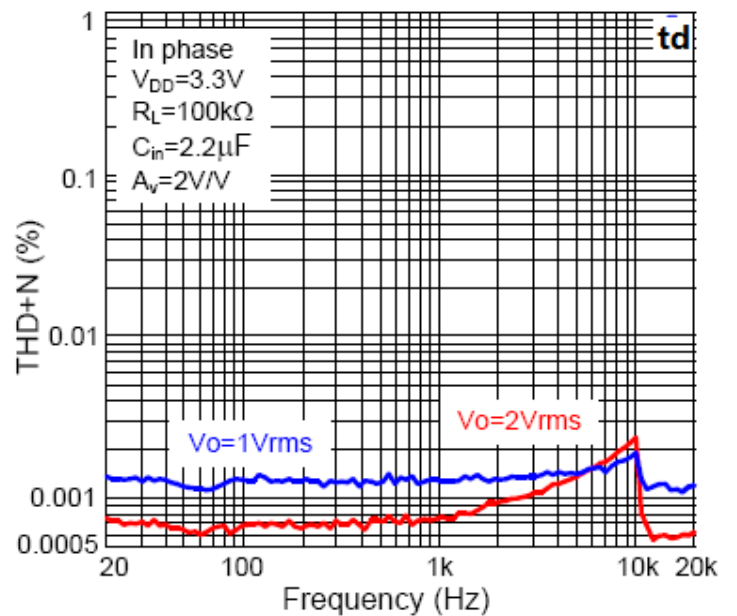

Typical Operating Characteristics(Cont.)

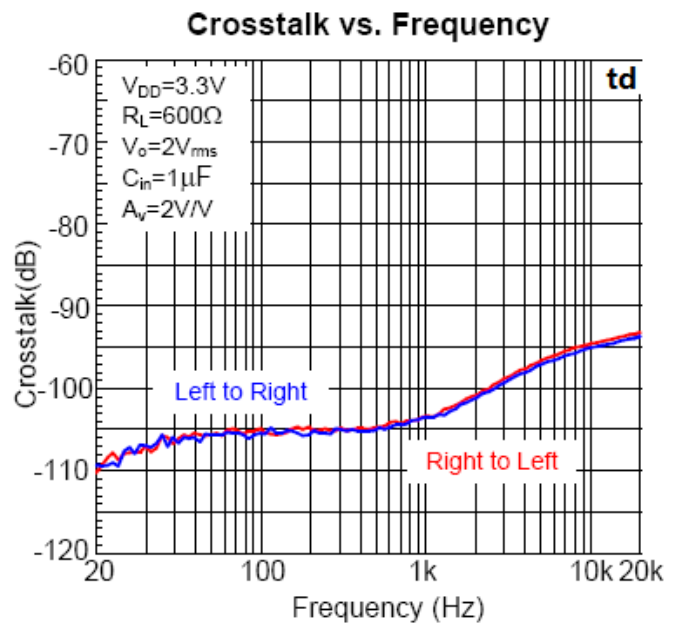
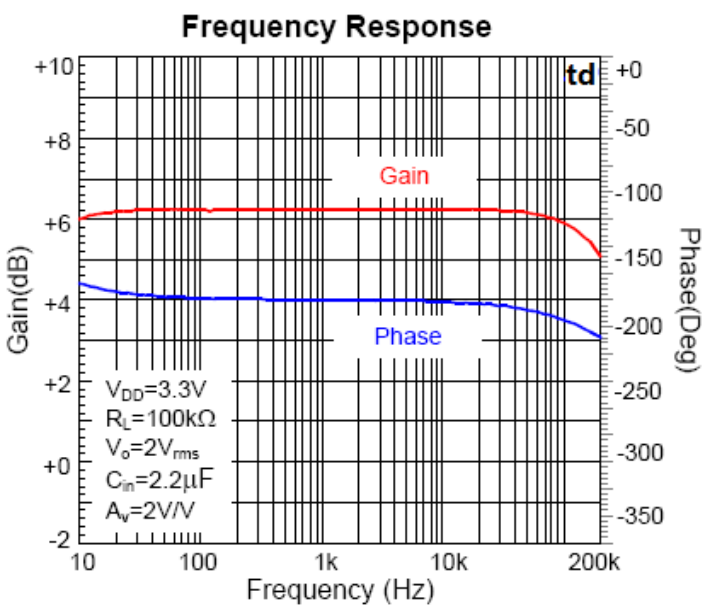
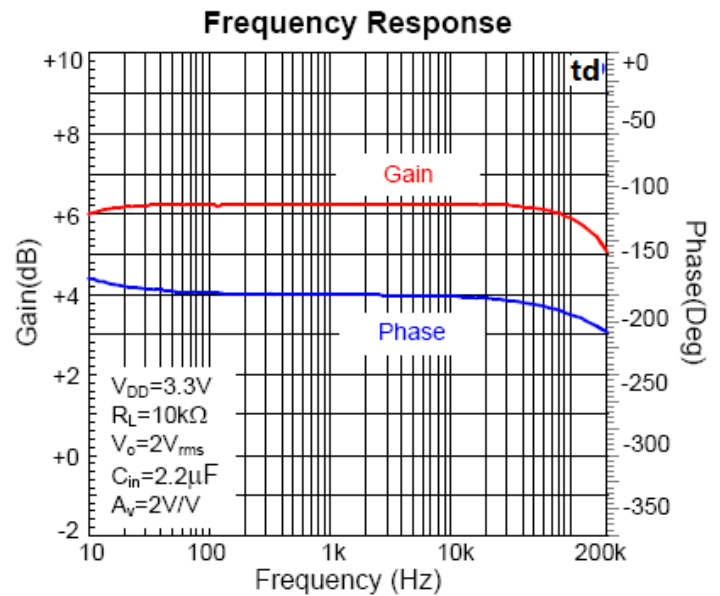
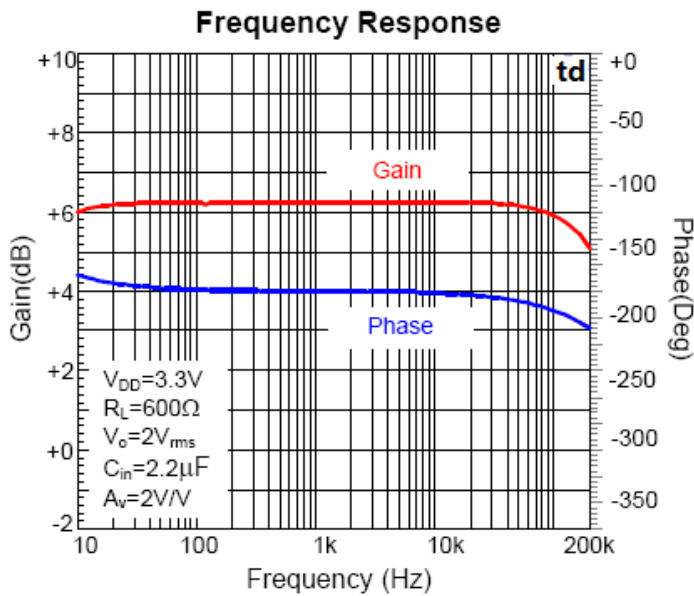

Typical Operating Characteristics(Cont.)

Crosstalk vs. Frequency

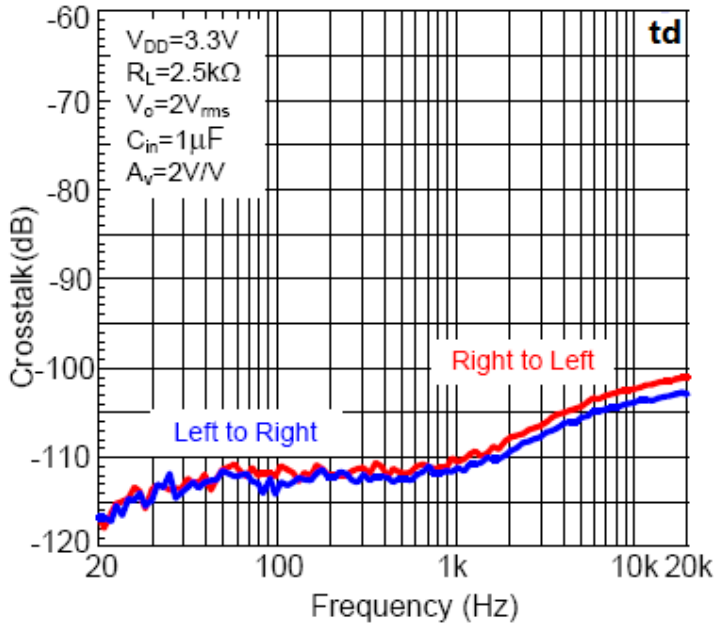

Crosstalk vs. Frequency

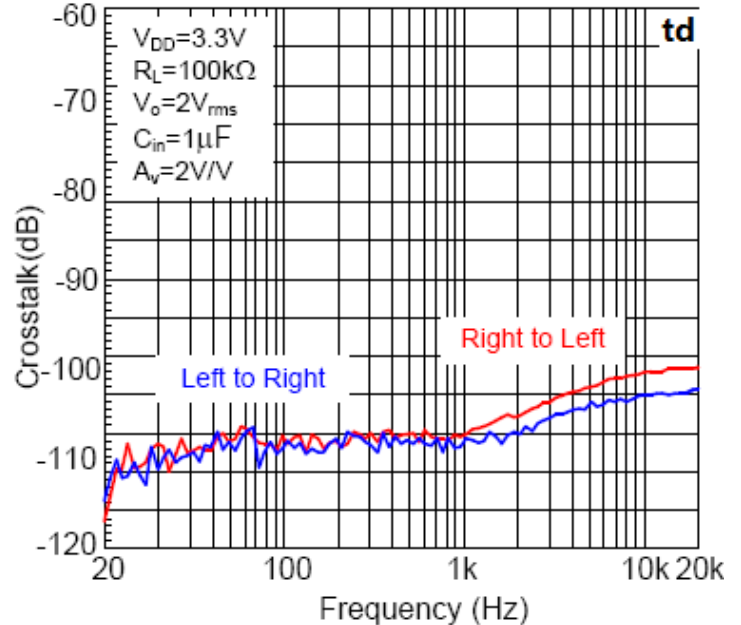

Output Noise Voltage vs. Frequency

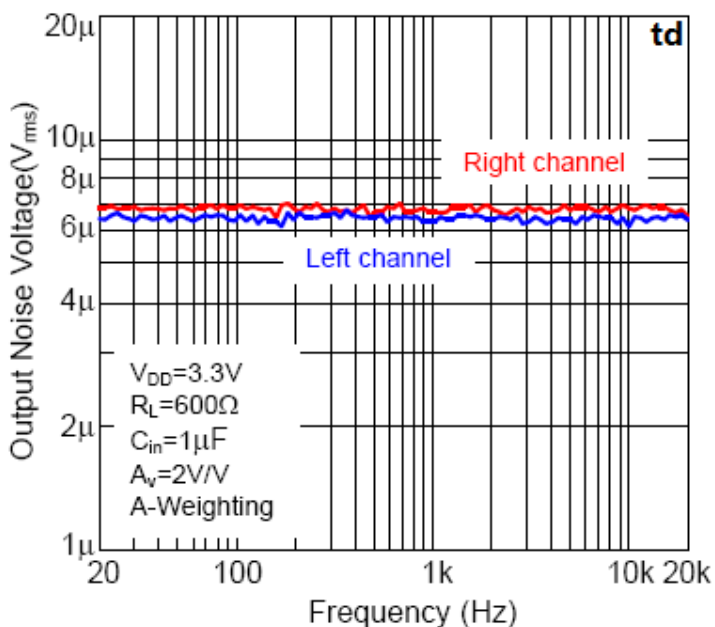

Output Noise Voltage vs. Frequency

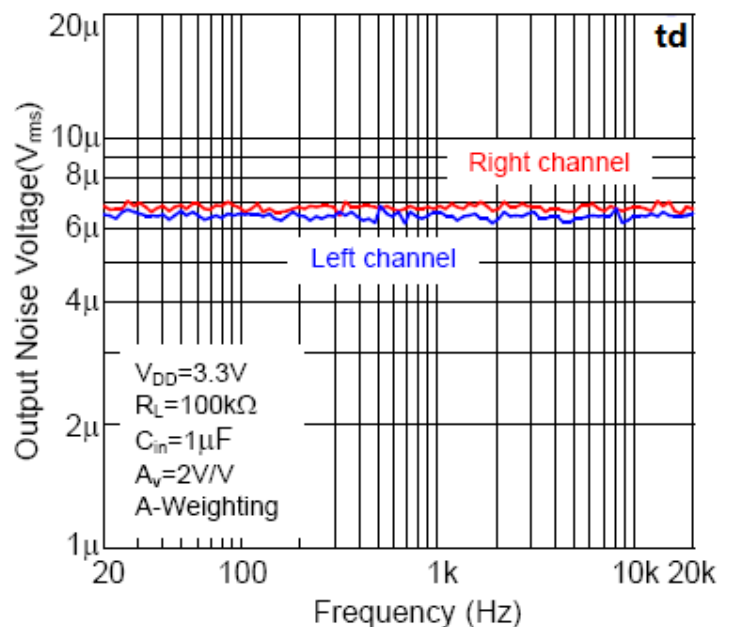

Typical Operating Characteristics(Cont.)

PSRR vs. Frequency

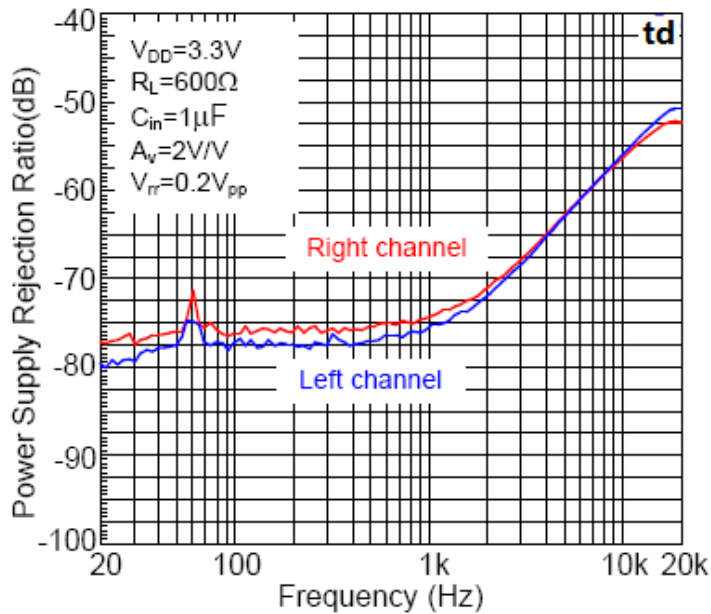

PSRR vs. Frequency

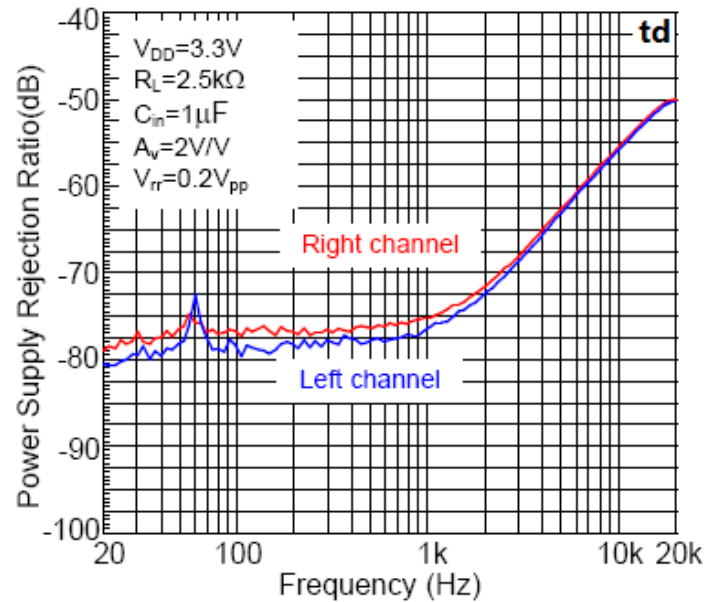

Supply Current vs. Supply Voltage

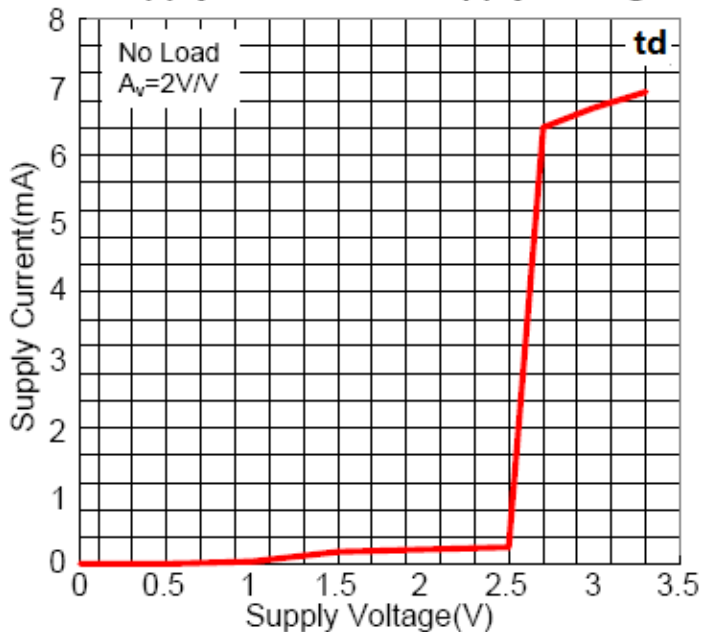

Type Application Circuit

Line Driver Amplifier

1. Inverting

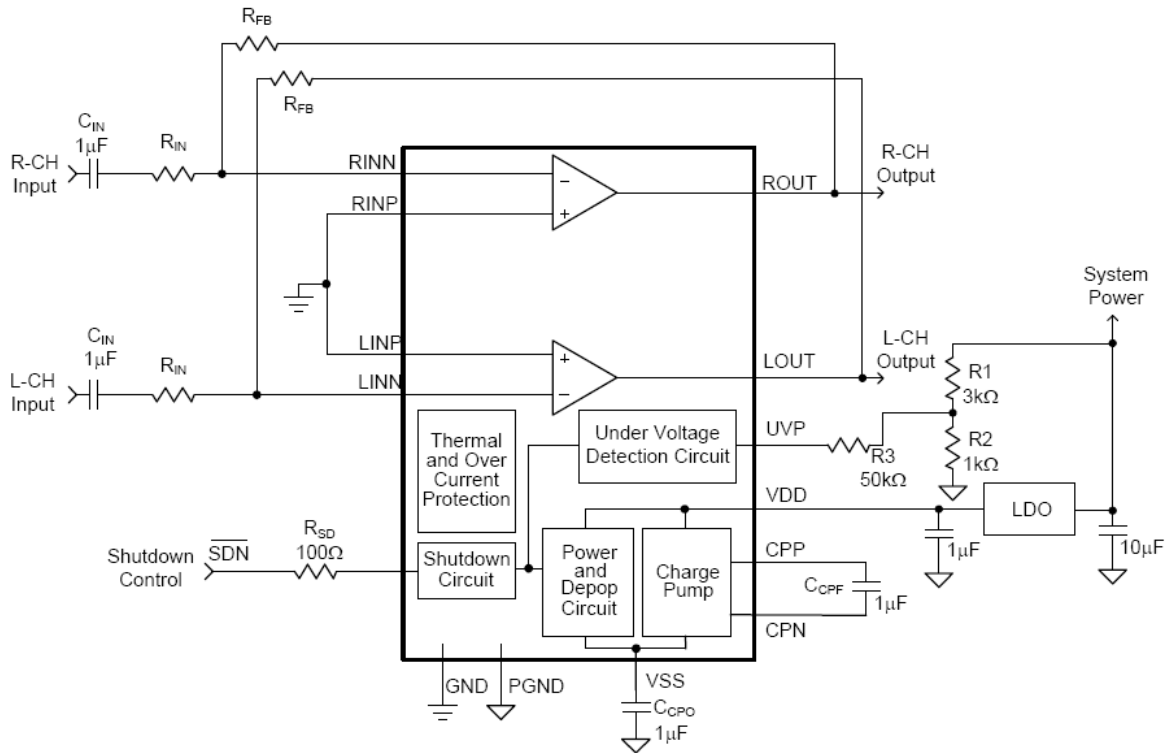

2. Non-Inverting

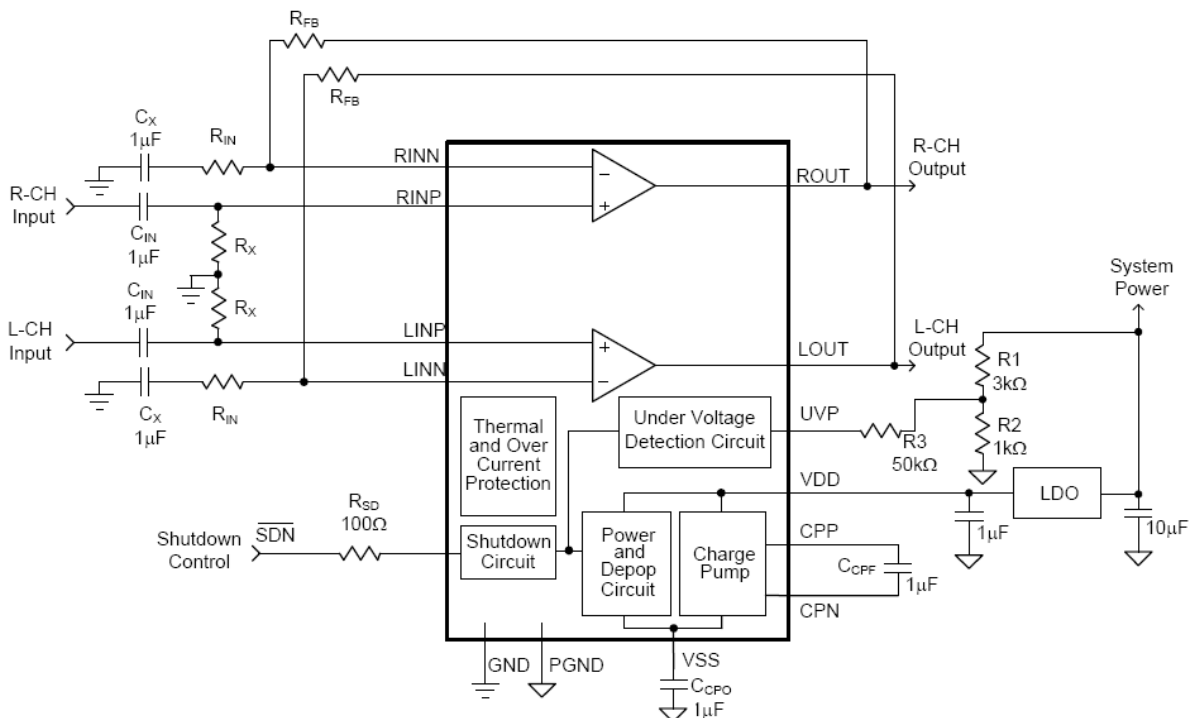

Type Application Circuit(Cont.)

Line Driver Amplifier (Cont.)

3. Differential

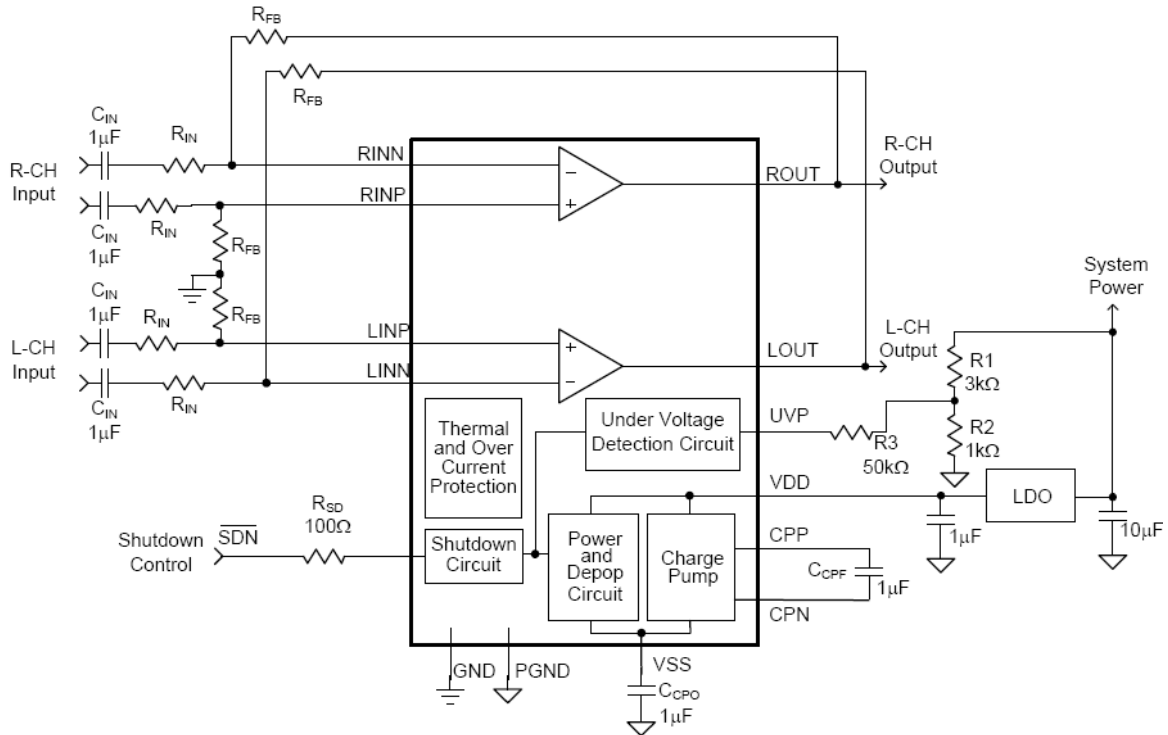

Second-Order Active Low-Pass Filter

1. Differential

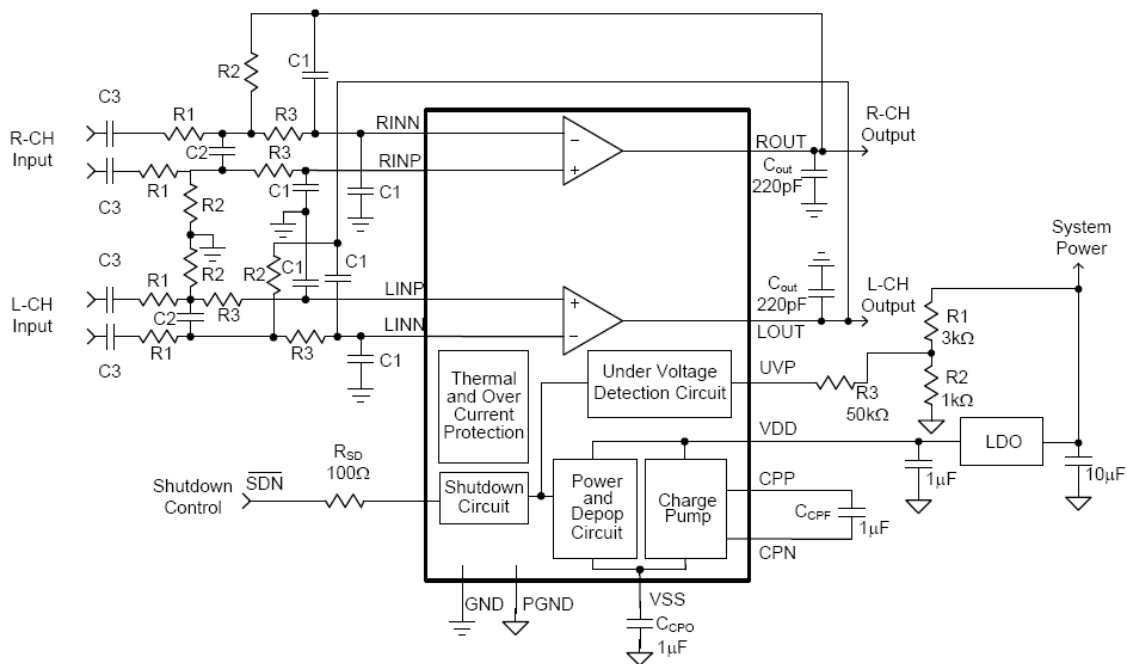

Type Application Circuit(Cont.)

Second-Order Active Low-Pass Filter

2. Inverting

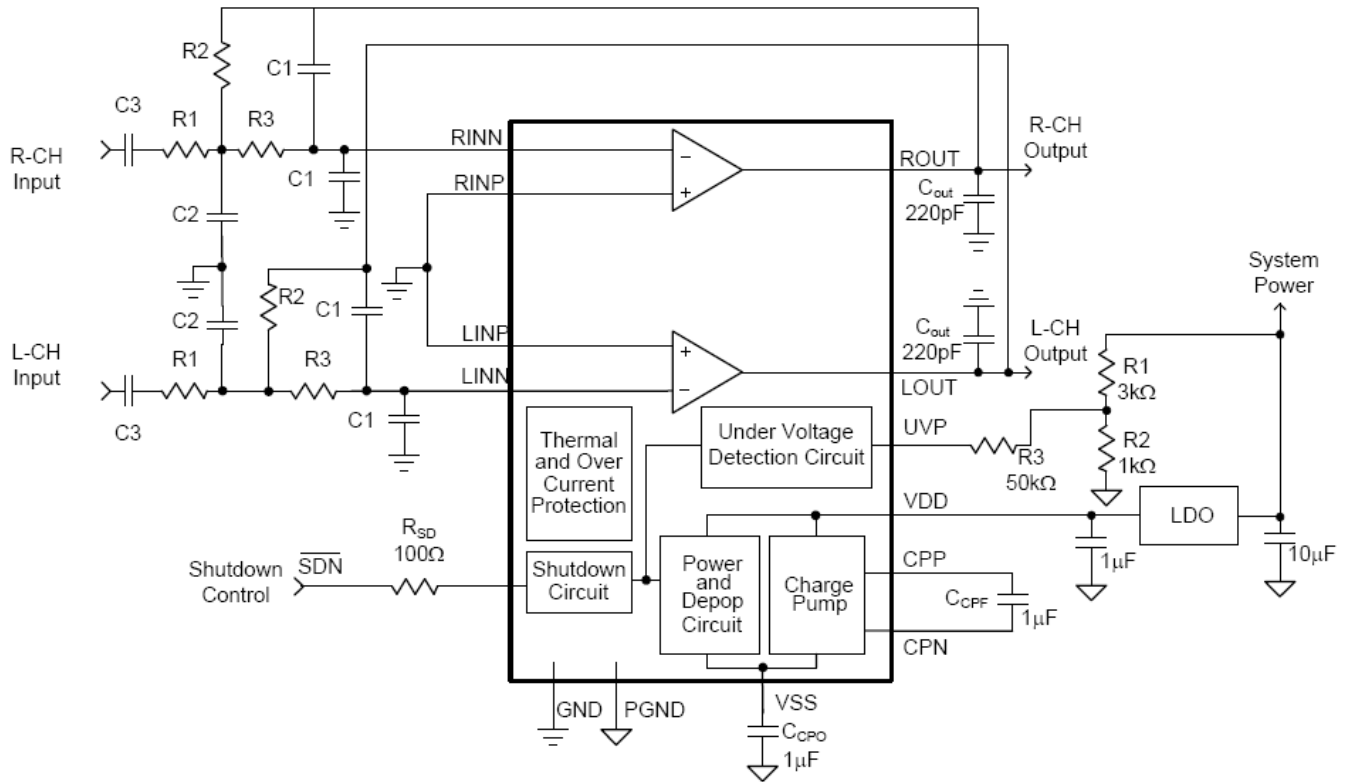

Function Description

Line Driver Operation

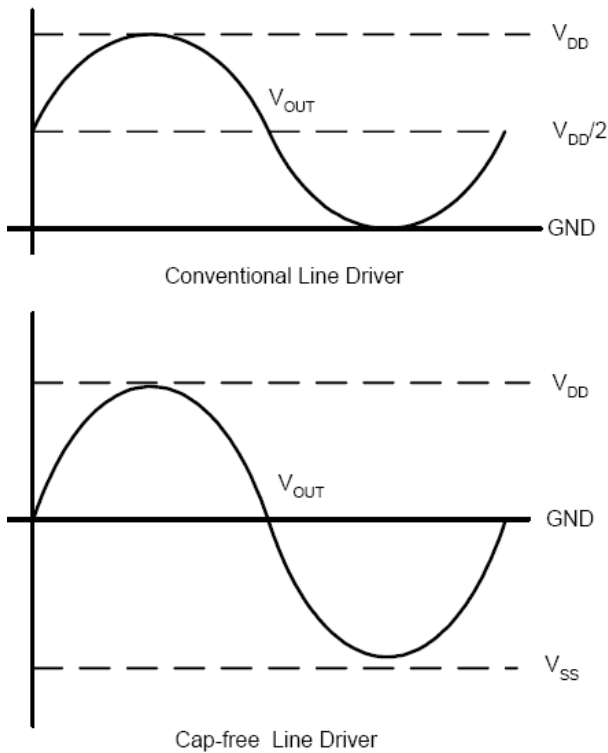

Figure 1. Cap-free Operation

The TD9721's line drivers use a charge pump to invert the positive power supply (V_{DD}) to negative power supply (V_{SS}), see figure1. The headphone drivers operate at this bipolar power supply (V_{DD} and V_{SS}) and the outputs reference refers to the ground. This feature eliminates the output capacitor that is using in conventional single-ended headphone drive amplifier. Compare with the single power supply amplifier, the power supply range has almost doubled.

Thermal Protection

The thermal protection circuit limits the junction temperature of the TD9721. When the junction temperature exceeds $T_J=+150^{\circ}C$, a thermal sensor turns off the driver, allowing the devices to cool. The thermal sensor allows the driver to start-up after the junction temperature down about $125^{\circ}C$. The thermal protection is designed with a $25^{\circ}C$ hysteresis to lower the average T_J during continuous thermal overload conditions, increasing lifetime of the ICs.

Shutdown Function

In order to reduce power consumption while not in use, the TD9721 contains shutdown controllers to externally turn off the amplifier bias circuitry. This shutdown feature turns the amplifier off when logic low is placed on the SDN pins for the TD9721. The trigger point between a logic high is 1.0V and logic low level is 0.35V. It is recommended to switch between ground and the supply voltage V_{DD} to provide maximum device performance. By switching the SDN pins to a low level, the amplifier enters a low-consumption current circumstance, charge pump is disabled, and I_{DD} for the TD9721 is in shutdown mode. In normal operating, the TD9721's SDN pins should be pulled to a high level to keep the IC out of the shutdown mode. The SDN pins should be tied to a definite voltage to avoid unwanted circumstance changes.

Under-Voltage Protection

External under voltage detection can be used to shutdown the TD9721 before an input device can generate a pop. The shutdown threshold at the UVP pin is 1.25V. The user selects a resistor divider to obtain the shutdown threshold and hysteresis for the specific application. The thresholds can be determined as below:

$$V_{UVP} = (1.25 - 6\mu A \times R_3) \times (R_1 + R_2) / R_2$$

$$\text{Hysteresis} = 5\mu A \times R_3 \times (R_1 + R_2) / R_2$$

$$\text{With the condition: } R_3 \gg R_1 // R_2$$

For example, to obtain $V_{UVP}=3.8V$ and 1V hysteresis, $R_1=3k\Omega$, $R_2=1k\Omega$ and $R_3=50k\Omega$.

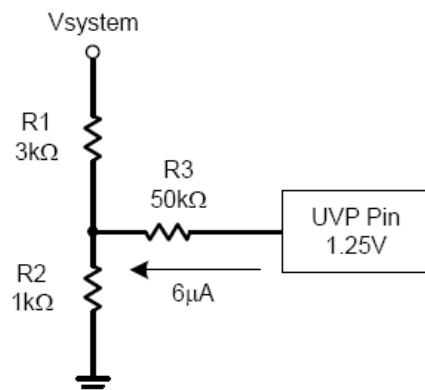

Figure 2. Under-Voltage Protection

Application Information

Using The TD9721 As A Second-Order Filter

Several audio DACs used today require an external lowpass filter to remove out-of-band noise. This is possible with the TD9721, as it can be used like a standard Operational Amplifier. Several filter topologies can be implemented, both single-ended and differential. In Figure 3, a multi-feedback (MFB) with differential input and single-ended output is shown.

An ac-coupling capacitor to remove dc content from the source is shown; it serves to block any dc content from the source and lowers the dc-gain to 1, helping reducing the output dc-offset to minimum.

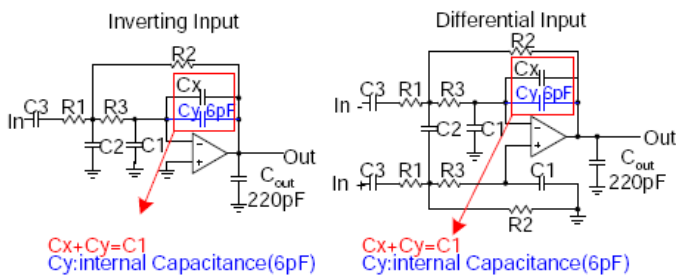

Figure 3. Second-Order Active Low-Pass Filter

Gain (V/V)	High Pass (Hz)	Low Pass (kHz)	C1 (pF)	C2 (pF)	C3 (μF)	R1 (kΩ)	R2 (kΩ)	R3 (kΩ)
-1	1.6	40	100	680	10	10	10	24
-1.5	1.3	40	68	680	15	8.2	12	30
-2	1.6	60	33	150	6.8	15	30	47
-2	1.6	30	47	470	6.8	15	30	43
-3.33	1.2	30	33	470	10	13	43	43
-10	1.5	30	22	1000	22	4.7	47	27

For Inverting Input, The overall gain is:

$$A_V = -\frac{R_2}{R_1}$$

The high pass filter's cutoff frequency is:

$$f_{c(\text{highpass})} = \frac{1}{2\pi R_1 C_3}$$

The low pass filter's cutoff frequency is:

$$f_{c(\text{lowpass})} = \frac{1}{2\pi\sqrt{R_2 R_3 C_1 C_2}}$$

Input Capacitor, Ci

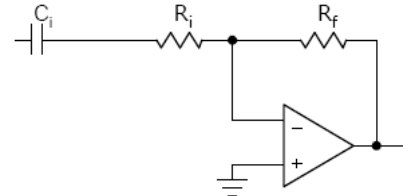

Figure 4. Typical Application Circuit

In the typical application, an input capacitor, C_i , is required to allow the amplifier to bias the input signal to the proper DC level for optimum operation. In this case, C_i and the minimum input impedance R_i from a high-pass filter with the corner frequency are determined in the following equation:

$$f_{c(\text{highpass})} = \frac{1}{2\pi R_i C_i}$$

The value of C_i must be considered carefully because it directly affects the low frequency performance of the circuit. R_i is the external input resistance that typical value is 10kΩ and the specification calls for a flat bass response down to 20Hz. Equation is reconfigured as below:

$$C_i = \frac{1}{2\pi R_i f_{c(\text{highpass})}}$$

When the input resistance variation is considered, the C_i is 0.8μF, so a value in the range of 1μF to 2.2μF would be chosen. A further consideration for this capacitor is the leakage path from the input source through the input network ($R_i + R_f$, C_i) to the load.

This leakage current creates a DC offset voltage at the input to the amplifier that reduces useful headroom, especially in high gain applications. For this reason, a low leakage tantalum or ceramic capacitor is the best choice. When polarized capacitors are used, the negative side of the capacitor should face the amplifiers' input in most applications because the DC level of the amplifiers' input is held at GND. Please note that it is important to confirm the capacitor polarity in the application.

Input Resistor, Ri

The gain of the TD9721 is set by the external input resistor (R_i) and external feedback resistor (R_f). Please see the figure 4.

Application Information(Cont.)

Input Resistor, R_i (Cont.)

$$\text{Gain } (A_v) = \frac{R_f}{R_i}$$

The external gain setting is recommended using from -1V/V to -10V/V, and the R_i is in the range from 1kΩ to 47kΩ. It's recommended to use 1% tolerance resistor or better. Keep the input trace as short as possible to limit the noise injection. The gain is recommended to set -1V/V, and R_i is 10kΩ, and R_f is 10kΩ.

Feedback Resistor, R_f

Refer the figure 4, the external gain is setting by R_i and R_f; and the gain setting is recommended using from -1V/V to -10V/V. The R_f is in the range from 4.7kΩ to 100kΩ. It's recommended to use 1% tolerance resistor or better.

Power Supply Decoupling, C_s

The TD9721 is a high-performance CMOS audio amplifier that requires adequate power supply decoupling to ensure the output total harmonic distortion (THD+N) is as low as possible. Power supply decoupling also prevents the oscillations being caused by long lead length between the amplifier and the speaker.

The optimum decoupling is achieved by using two different types of capacitors that target on different types of noise on the power supply leads. For higher frequency transients, spikes, or digital hash on the line, a good low equivalent-series-resistance (ESR) ceramic capacitor, typically 0.1μF, is placed as close as possible to the device VDD and PVDD lead for the best performance. For filtering lower frequency noise signals, a large aluminum electrolytic capacitor of 10μF or greater placed near the audio power amplifier is recommended.

Charge Pump Flying Capacitor, C_{CPF}

The flying capacitor affects the load transient of the charge pump. If the capacitor's value is too small, then that will degrade the charge pump's current driver capability and the performance of line drive amplifier.

Increasing the flying capacitor's value will improve the load transient of charge pump. It is recommended using the low ESR ceramic capacitors (X7R type is recommended) above 1μF.

Charge Pump Output Capacitor, C_{CPO}

The output capacitor's value affects the power ripple directly at CV_{SS} (V_{SS}). Increasing the value of output capacitor reduces the power ripple. The ESR of output capacitor affects the load transient of CV_{SS} (V_{SS}). Lower ESR and greater than 1μF ceramic capacitor is a recommendation.

Layout Recommendation

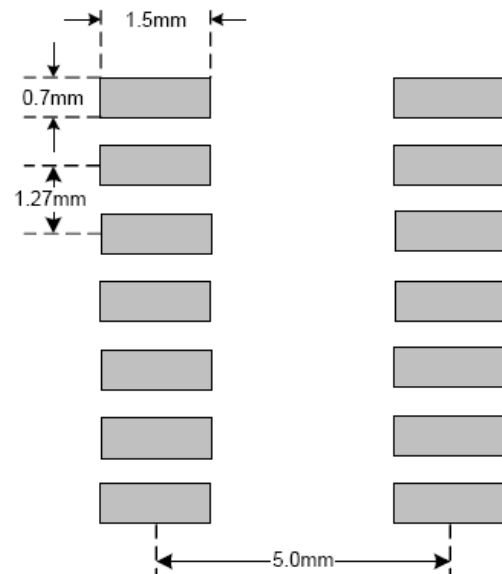

SOP-14 Land Pattern Recommendation

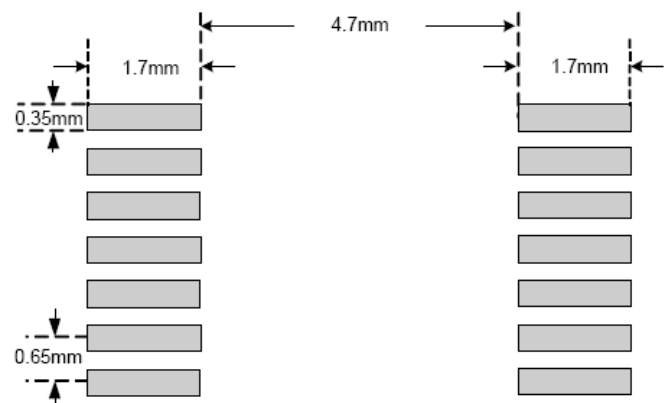

TSSOP-14 Land Pattern Recommendation

Package Information

TSSOP-14

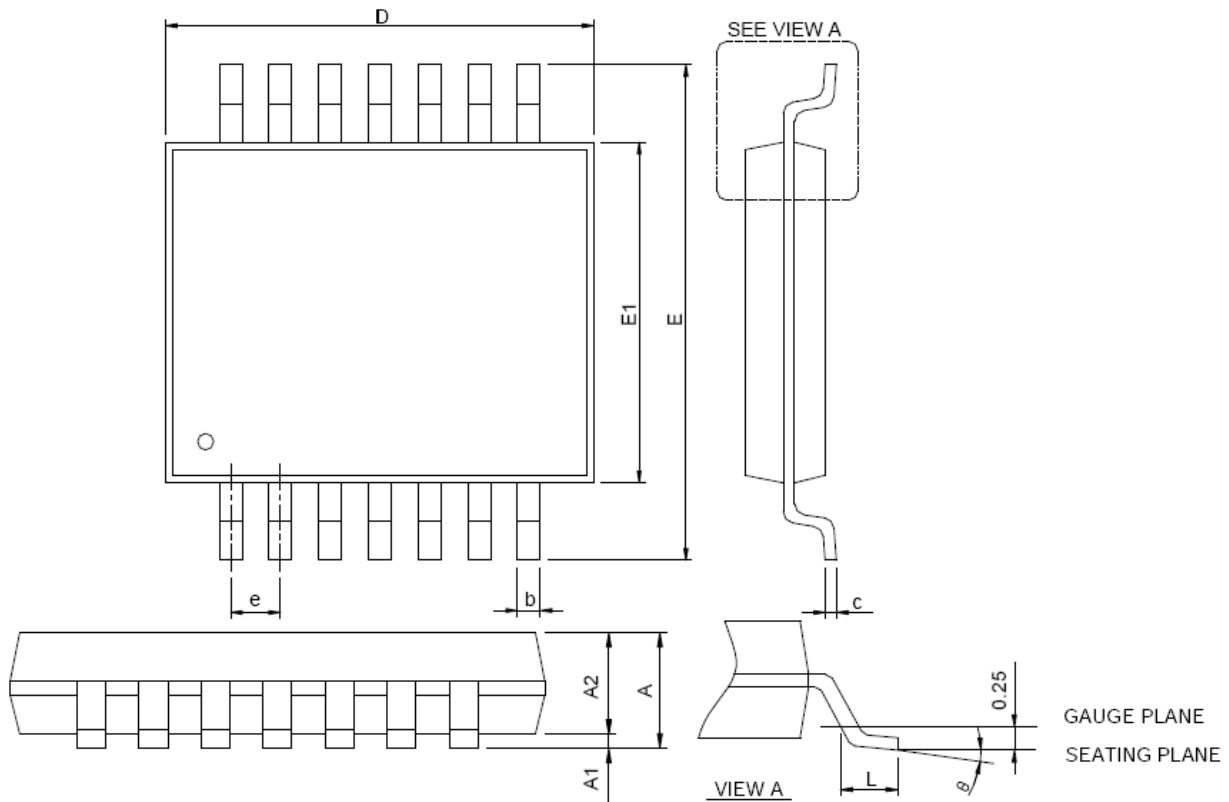

SYMBOL	TSSOP-14			
	MILLIMETERS		INCHES	
	MIN.	MAX.	MIN.	MAX.
A		1.20		0.047
A1	0.05	0.15	0.002	0.006
A2	0.80	1.05	0.031	0.041
b	0.19	0.30	0.007	0.012
c	0.09	0.20	0.004	0.008
D	4.90	5.10	0.193	0.201
E	6.20	6.60	0.244	0.260
E1	4.30	4.50	0.169	0.177
e	0.65 BSC		0.026 BSC	
L	0.45	0.75	0.018	0.030
θ	0°	8°	0°	8°

Package Information(Cont.)

SOP-14

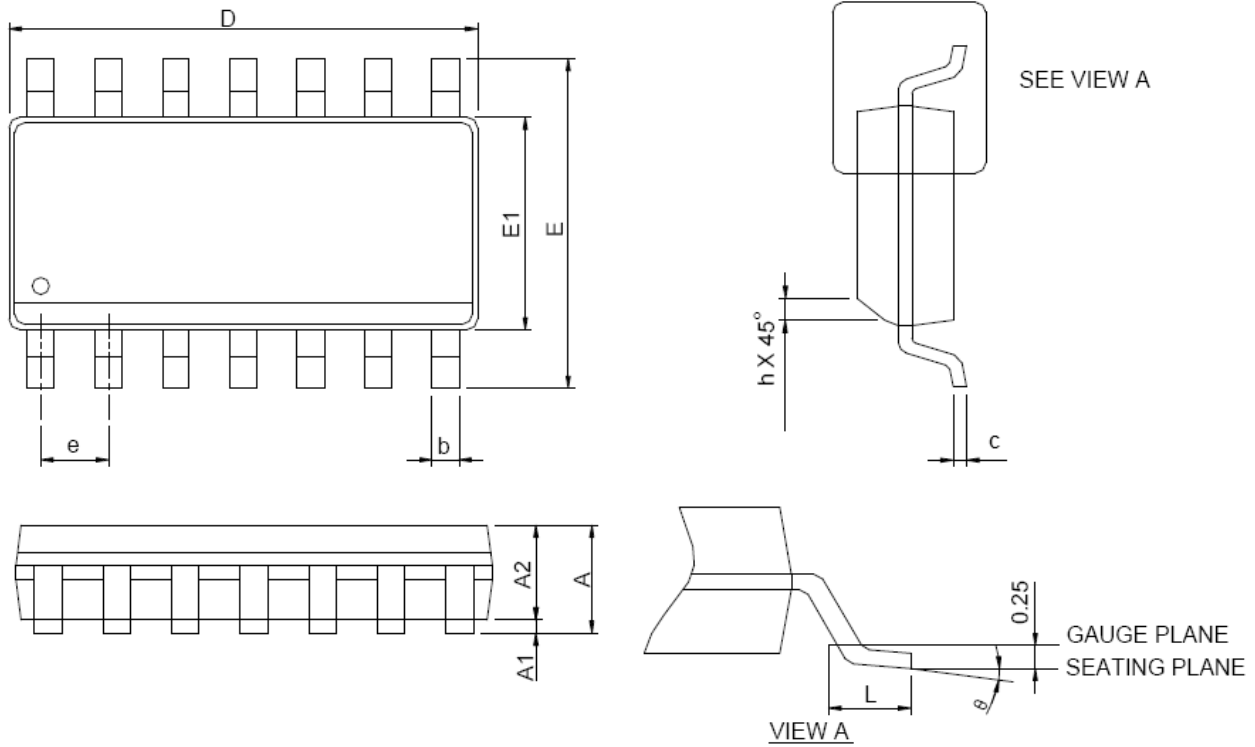

SYMBOL	SOP-14			
	MILLIMETERS		INCHES	
	MIN.	MAX.	MIN.	MAX.
A		1.75		0.069
A1	0.10	0.25	0.004	0.010
A2	1.25		0.049	
b	0.31	0.51	0.012	0.020
c	0.17	0.25	0.007	0.010
D	8.55	8.75	0.337	0.344
E	5.80	6.20	0.228	0.244
E1	3.80	4.00	0.150	0.157
e	1.27 BSC		0.050 BSC	
h	0.25	0.50	0.010	0.020
L	0.40	1.27	0.016	0.050
θ	0°	8°	0°	8°

Design Notes