

OPERATIONAL AMPLIFIER

The TDA1034 is a high-performance general purpose operational amplifier. Compared to most of the standard operational amplifiers (e.g. μ A741, TBA221, LM301A and LM307), it shows better noise performance, improved output drive capability and considerably higher small-signal and power bandwidth.

This makes the device especially suitable for application in high quality and professional audio equipment, in instrumentation and control circuits and telephone channel amplifiers. The op amp is internally compensated for gain equal to, or higher than, three.

The frequency response can be optimized with an external compensation capacitor for various applications (unity gain amplifier, capacitive load, slew-rate, low overshoot, etc.). If very low noise is of prime importance, it is recommended that the TDA1034N version be used which has guaranteed noise specifications and somewhat lower input current.

Features

- Small-signal bandwidth : 10 MHz
- Output drive capability : 600 Ω , 10 V (r.m.s.) at $V_P = -V_N = 18$ V
- Input noise voltage : 4 nV/ $\sqrt{\text{Hz}}$
- D.C. voltage gain : 100 000
- A.C. voltage gain : 6000 at 10 kHz
- Power bandwidth : 200 kHz
- Slew-rate : 13 V/ μ s
- Large supply voltage range : ± 3 to ± 20 V

PACKAGE OUTLINES (see general section).

TDA1034; N : TO-99 (8-lead metal envelope).

TDA1034B; NB : SOT-97 (plastic 8-lead dual in-line).

TDA1034D; ND : SO-8 (SOT-96A) (plastic 8-lead flat pack).

TDA1034A; N
TDA1034B; NB
TDA1034D; ND

CIRCUIT DIAGRAM

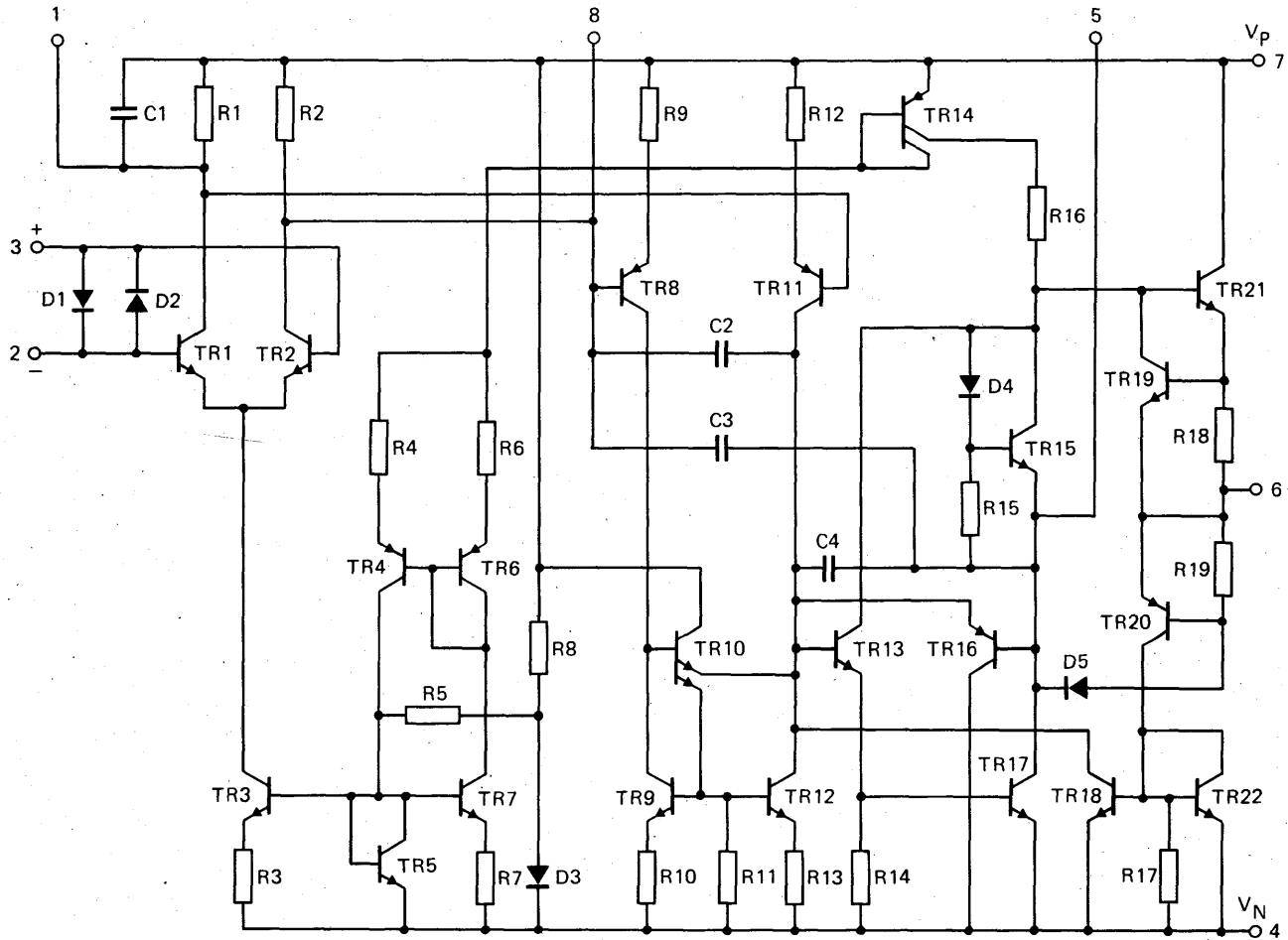

7272711.1

CHARACTERISTICS at $V_P = 15\text{ V}$; $-V_N = 15\text{ V}$; $T_{\text{amb}} = 25\text{ }^\circ\text{C}$ unless otherwise specified

| | | | | |
|--|-------------|------|----------|------------------------|
| Input offset voltage | V_{io} | typ. | 0,5 | mV |
| | | < | 4,0 | mV |
| Input bias current | I_i | typ. | 0,5 | μA |
| | | < | 1,5 | μA |
| Input offset current | I_{io} | typ. | 0,02 | μA |
| | | < | 0,3 | μA |
| Input voltage range | V_i | > | +12; -13 | V |
| | | typ. | +13; -14 | V |
| Differential input resistance | R_i | > | 30 | $\text{k}\Omega$ |
| | | typ. | 100 | $\text{k}\Omega$ |
| Common mode rejection ratio | CMRR | > | 80 | dB |
| | | typ. | 100 | dB |
| Power supply voltage rejection ratio | PSRR | typ. | 10 | $\mu\text{V}/\text{V}$ |
| | | < | 50 | $\mu\text{V}/\text{V}$ |
| Large-signal voltage gain $R_L = 600\ \Omega$; $V_o = \pm 10\text{ V}$ | G_v | > | 30 000 | |
| | | typ. | 100 000 | |
| Output voltage swing at $R_L = 600\ \Omega$ | V_o | > | ± 12 | V |
| | | typ. | ± 13 | V |
| Output resistance; closed loop $G_v = 30\ \text{dB}$; $f = 10\ \text{kHz}$; $R_L = 600\ \Omega$; $C_C = 22\ \text{pF}$ | R_o | typ. | 0,3 | Ω |
| | | | | |
| Output short-circuit current | I_{sc} | typ. | 38 | mA |
| Supply current at $I_o = 0$ | I_P ; N | typ. | 4 | mA |
| | | < | 6,5 | mA |
| Transient response (voltage follower) | | | | |
| $V_i = 50\ \text{mV}$; $R_L = 600\ \Omega$; $C_C = 22\ \text{pF}$; $C_L = 100\ \text{pF}$ | | | | |
| rise time | t_r | typ. | 20 | ns |
| overshoot | | typ. | 20 | % |
| $V_i = 50\ \text{mV}$; $R_L = 600\ \Omega$; $C_C = 47\ \text{pF}$; $C_L = 500\ \text{pF}$ | | | | |
| rise time | t_r | typ. | 50 | ns |
| overshoot | | typ. | 35 | % |
| A.C. gain at $f = 10\ \text{kHz}$; $C_C = 0$ | G_v | typ. | 6000 | |
| | | | | |
| at $f = 10\ \text{kHz}$; $C_C = 22\ \text{pF}$ | G_v | typ. | 2200 | |
| Unity gain frequency at $C_C = 22\ \text{pF}$; $C_L = 100\ \text{pF}$ | f | typ. | 10 | MHz |
| Slew-rate at $C_C = 0$ | S | typ. | 13 | $\text{V}/\mu\text{s}$ |
| | | | | |
| at $C_C = 22\ \text{pF}$ | S | typ. | 6 | $\text{V}/\mu\text{s}$ |
| Power bandwidth at $V_{o(p-p)} = 20\ \text{V}$ | B | typ. | 200 | kHz |
| | | | | |
| $C_C = 0$ | B | typ. | 95 | kHz |
| $C_C = 22\ \text{pF}$ | B | typ. | | |

CHARACTERISTICS (continued)

| | | | | |
|--|-------|------|-----|------------------------------|
| Input noise voltage at $f = 30 \text{ Hz}$ | V_n | typ. | 7 | $\text{nV}/\sqrt{\text{Hz}}$ |
| at $f = 1 \text{ kHz}$ | V_n | typ. | 4 | $\text{nV}/\sqrt{\text{Hz}}$ |
| Input noise current at $f = 30 \text{ Hz}$ | I_n | typ. | 2,5 | $\text{pA}/\sqrt{\text{Hz}}$ |
| at $f = 1 \text{ kHz}$ | I_n | typ. | 0,6 | $\text{pA}/\sqrt{\text{Hz}}$ |

CHARACTERISTICS at $V_p = 18 \text{ V}$; $-V_N = 18 \text{ V}$; $T_{\text{amb}} = 25 \text{ }^\circ\text{C}$ unless otherwise specified

| | | | | |
|---|-----------|------|----------|-----|
| Output voltage swing at $R_L = 600 \Omega$ | V_o | > | ± 15 | V |
| | | typ. | ± 16 | V |
| Supply current at $I_o = 0$ | $I_{P;N}$ | typ. | 4,2 | mA |
| | | < | 7 | mA |
| Power bandwidth at $V_o(\text{p-p}) = 28 \text{ V}$ $R_L = 600 \Omega$; $C_C = 22 \text{ pF}$ | B | typ. | 70 | kHz |

TDA1034N version

The TDA1034N version has the same electrical specifications as the TDA1034, with the following exceptions:

| | | | | |
|--|----------|------|------|------------------------------|
| Input bias current | I_i | typ. | 0,4 | μA |
| | | < | 0,8 | μA |
| Input offset current | I_{io} | typ. | 0,01 | μA |
| | | < | 0,2 | μA |
| Input noise voltage at $f = 30 \text{ Hz}$ | V_n | typ. | 5,5 | $\text{nV}/\sqrt{\text{Hz}}$ |
| | | < | 7 | $\text{nV}/\sqrt{\text{Hz}}$ |
| at $f = 1 \text{ kHz}$ | V_n | typ. | 3,5 | $\text{nV}/\sqrt{\text{Hz}}$ |
| | | < | 4,5 | $\text{nV}/\sqrt{\text{Hz}}$ |
| Input noise current at $f = 30 \text{ Hz}$ | I_n | typ. | 1,5 | $\text{pA}/\sqrt{\text{Hz}}$ |
| at $f = 1 \text{ kHz}$ | I_n | typ. | 0,4 | $\text{pA}/\sqrt{\text{Hz}}$ |
| Broadband noise figure $f = 10 \text{ Hz to } 20 \text{ kHz}$; $R_S = 5 \text{ k}\Omega$ | F | typ. | 0,9 | dB |

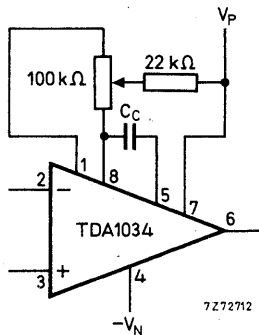

Frequency compensation and offset voltage adjustment circuit.

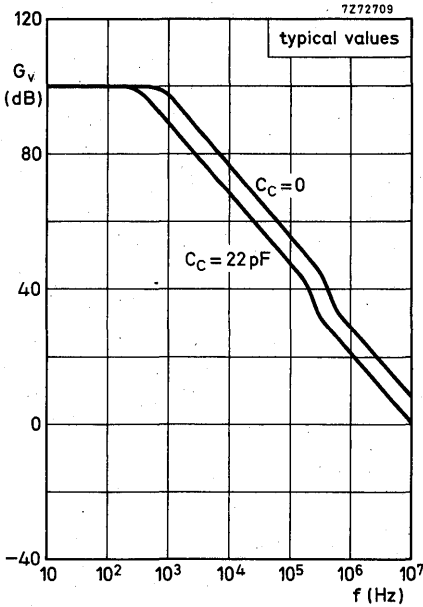

Open loop frequency response.

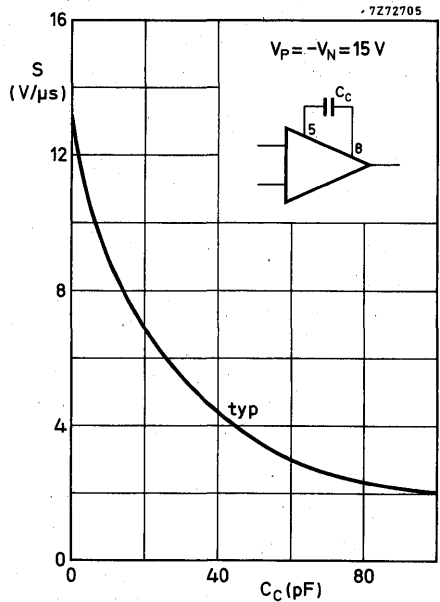

Slew-rate as a function of compensation capacitance.

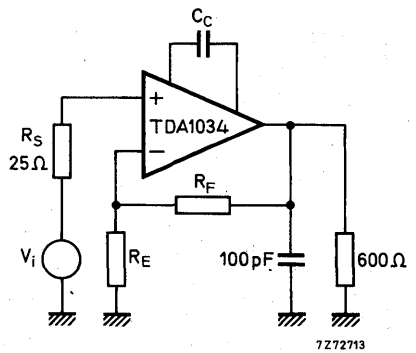
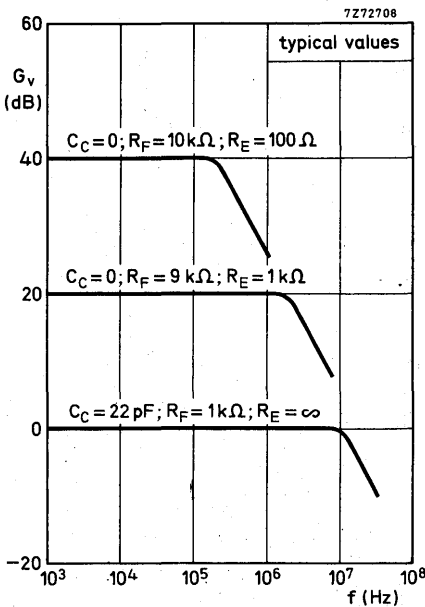

Closed loop frequency response.

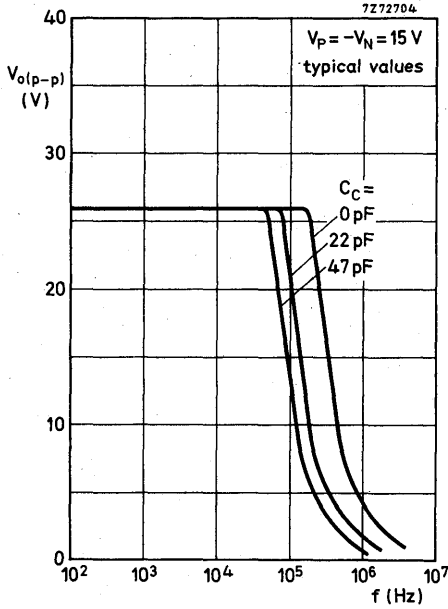

Large-signal frequency response.

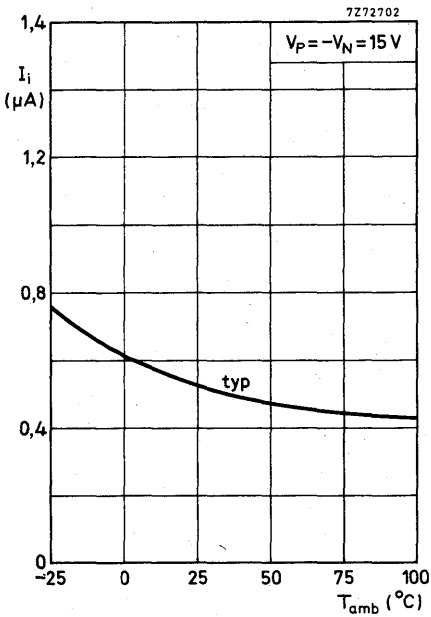

Input bias current.

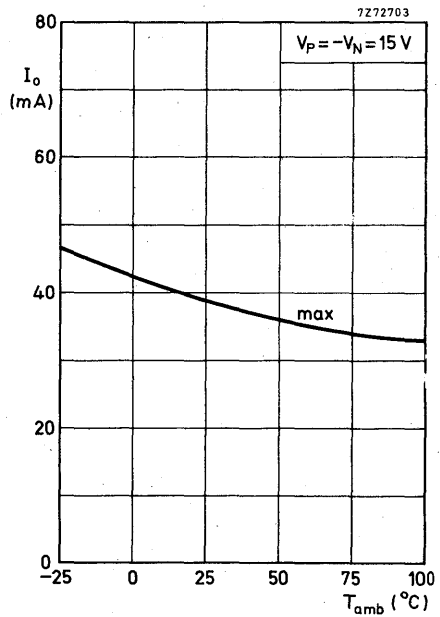

Output short-circuit current.

7Z72700.1

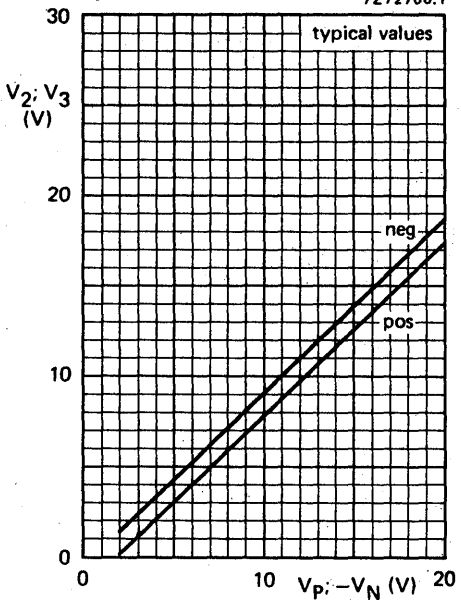

Input common mode voltage range.

7Z72699.1

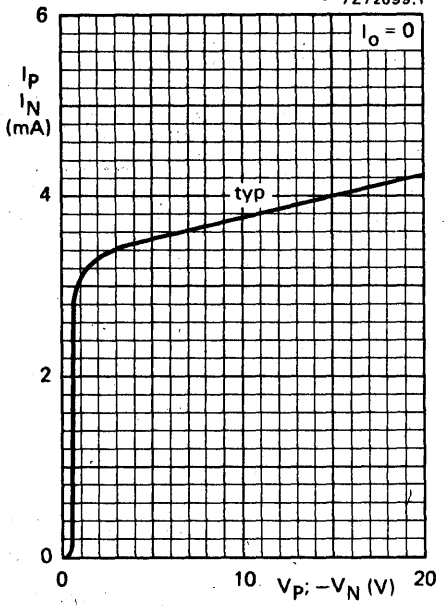

Supply current.

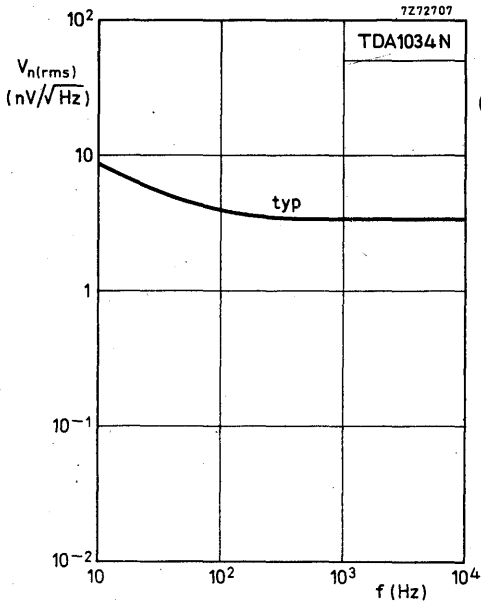

Input noise voltage density.

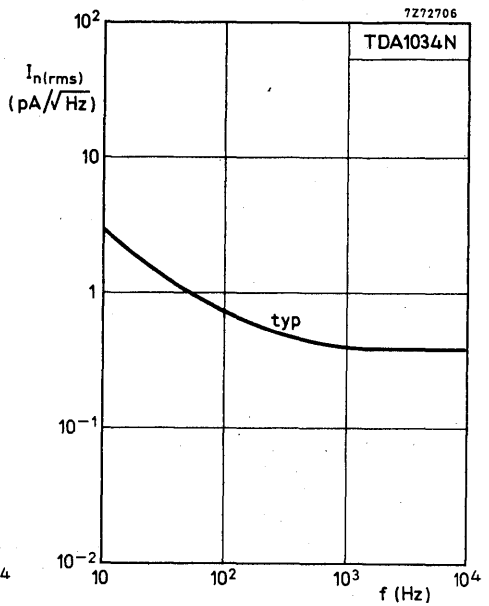

Input noise current density.

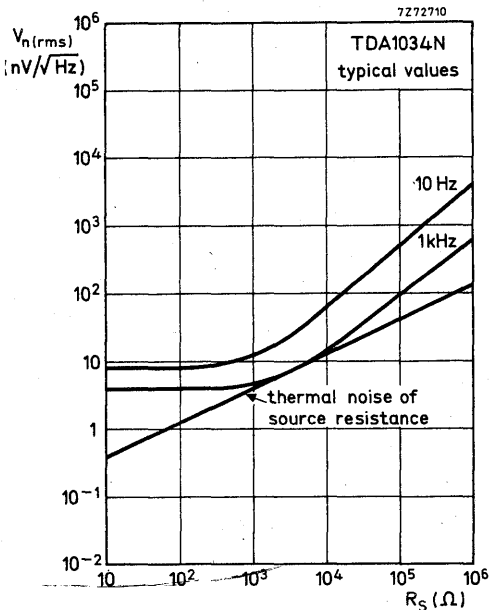

Total input noise density.

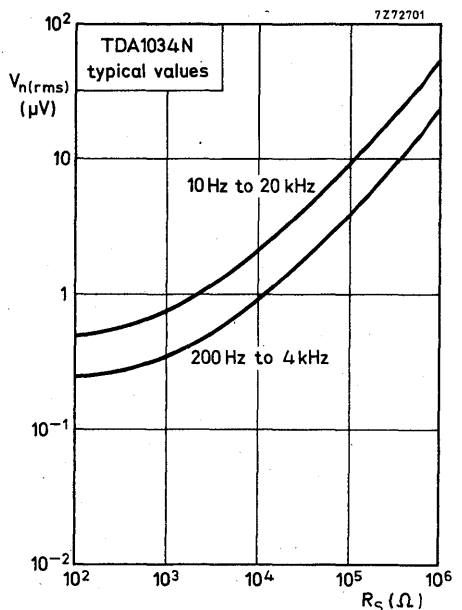

Broadband input noise voltage.