



TDA2005

LINEAR INTEGRATED CIRCUIT

20W BRIDGE AMPLIFIER FOR CAR RADIO

DESCRIPTION

The UTC **TDA2005** is class B dual audio power amplifier, have designed for car radio application.

FEATURES

* High output power:

$P_{OUT}=10+10W@R_L=2\Omega$, THD=10%

$P_{OUT}=20W@R_L=4\Omega$, THD=1%

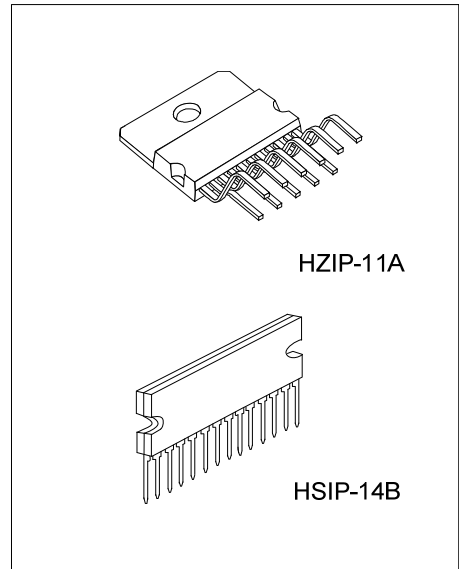

ORDERING INFORMATION

Ordering Number		Package	Packing
Lead Free	Halogen Free		
TDA2005L-J11-A-T	TDA2005G-J11-A-T	HZIP-11A	Tube
TDA2005L-H14-B-T	TDA2005G-H14-B-T	HSIP-14B	Tube

<p>TDA2005L-J11-A-T</p> <p>(1)Packing Type (2)Package Type (3)Lead Free</p>	<p>(1) T: Tube (2) J11-A:HZIP-11A, H14-B:HSIP-14B (3) G: Halogen Free, L: Lead Free</p>
-------------------------------------------------------------------------------------	-------------------------------------------------------------------------------------------------

■ PIN CONFIGURATION

HZIP-11A

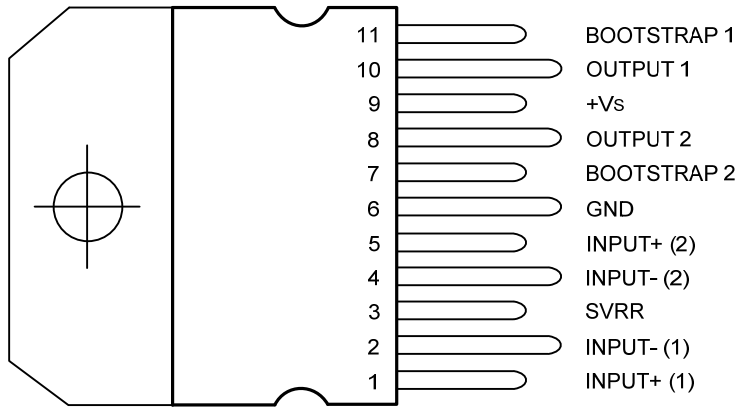

*TAB CONNECTED TO PIN 6

HSIP-14B

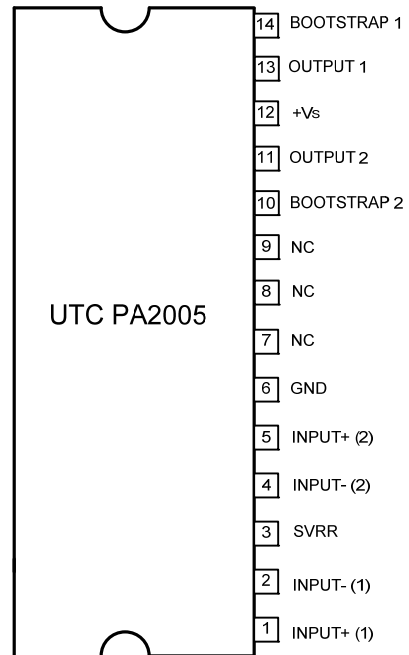

■ PIN DESCRIPTION

PIN NO.		PIN NAME
HZIP-11	HSIP-14*	
1	1	INPUT+ (1)
2	2	INPUT- (1)
3	3	SVRR
4	4	INPUT- (2)
5	5	INPUT+ (2)
6	6	GND
7	10	BOOTSTRAP 2
8	11	OUTPUT 2
9	12	+Vs
10	13	OUTPUT 1
11	14	BOOTSTRAP 1

* PIN 7, 8, 9 no connection.

■ BLOCK DIAGRAM

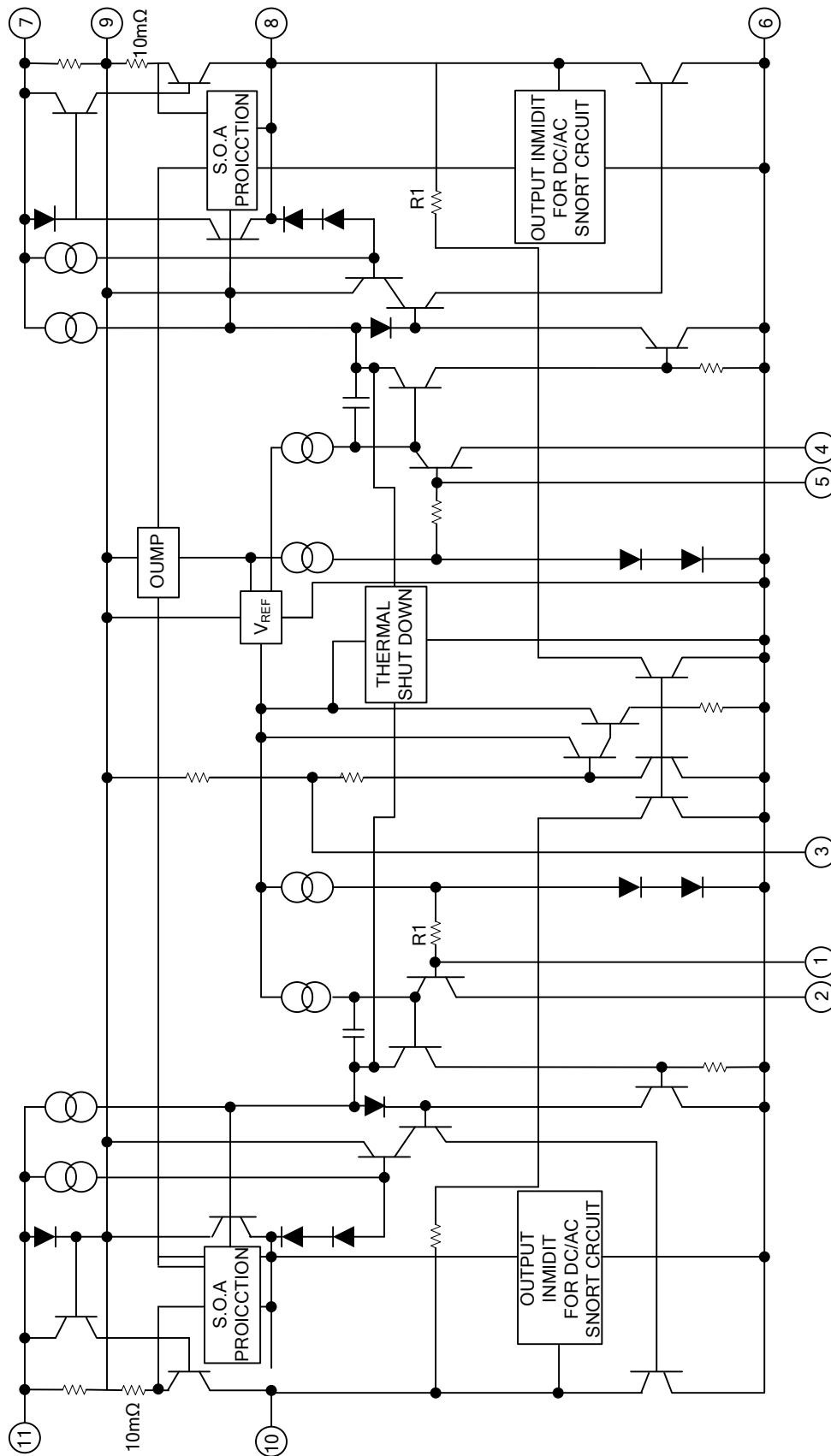

■ ABSOLUTE MAXIMUM RATINGS

PARAMETER	SYMBOL	RATINGS	UNIT	
Operating Supply Voltage	V_{SS}	18	V	
DC Supply Voltage	V_{SS}	28	V	
Peak Supply Voltage (for 50ms)	V_{SS}	40	V	
Output Peak Current (Note)	non repetitive $t=0.1\text{ms}$	I_o	4.5	A
	repetitive $f \geq 10\text{Hz}$	I_o	3.5	A
Power Dissipation at $T_C=60^\circ\text{C}$	P_D	30	W	
Junction Temperature	T_J	+150	$^\circ\text{C}$	
Storage Temperature	T_{STG}	-40 ~ 150	$^\circ\text{C}$	

Note: The max. output current is internally limited.

■ THERMAL DATA

PARAMETER	SYMBOL	RATINGS	UNIT
Junction to Case	θ_{JC}	3.0	$^\circ\text{C/W}$

■ ELECTRICAL CHARACTERISTICS

(Refer to the application circuit, $T_A=25^\circ\text{C}$, $G_V=50\text{dB}$, $R_{TH}(\text{heatsink})=4^\circ\text{C/W}$, unless otherwise specified.)

PARAMETER	SYMBOL	TEST CONDITIONS	MIN	TYP	MAX	UNIT
BRIDGE						
Supply Voltage	V_{SS}		8		18	V
Output Offset Voltage (between pin 8 and pin 10)	V_{OS}	$V_{SS}=14.4\text{V}$			150	mV
		$V_{SS}=13.2\text{V}$			150	
Total Quiescent Drain Current	I_D	$V_{SS}=14.4\text{V}$, $R_L=4\Omega$		75	150	mA
		$V_{SS}=13.2\text{V}$, $R_L=3.2\Omega$		70	160	
Output Power	P_{OUT}	THD=10%, $f=1\text{kHz}$	$V_{SS}=14.4\text{V}$, $R_L=4\Omega$	18	20	W
			$R_L=3.2\Omega$	20	22	
			$V_{SS}=13.2\text{V}$, $R_L=3.2\Omega$	17	19	
Total Harmonic Distortion $f=1\text{kHz}$	THD	$V_{SS}=14.4\text{V}$, $R_L=4\Omega$, $P_{OUT}=50\text{mW} \sim 15\text{W}$			1	%
		$V_{SS}=13.2\text{V}$, $R_L=3.2\Omega$, $P_{OUT}=50\text{mW} \sim 13\text{W}$			1	%
Input Sensitivity $f=1\text{kHz}$	V_{IN}	$P_{OUT}=2\text{W}$, $R_L=4\Omega$		9		mV
		$P_{OUT}=2\text{W}$, $R_L=3.2\Omega$		8		mV
Input Resistance	R_{IN}	$f=1\text{kHz}$	70			k Ω
Low Frequency Roll Off (-3dB)	f_L	$R_L=3.2\Omega$			40	Hz
High Frequency Roll Off (-3dB)	f_H	$R_L=3.2\Omega$	20			kHz
Closed Loop Voltage Gain	G_V	$f=1\text{kHz}$		50		dB
Total Input Noise Voltage	e_N	$R_G=10\text{k}\Omega$ (Note 1)		3	10	μV
Supply Voltage Rejection	SVR	$R_G=10\text{k}\Omega$, $C_4=10\mu\text{F}$ $F_{RIPPLE}=100\text{Hz}$, $V_{RIPPLE}=0.5\text{V}$	45	55		dB
Efficiency	η	$V_{SS}=14.4\text{V}$, $f=1\text{kHz}$	$P_{OUT}=20\text{W}$, $R_L=4\Omega$		60	%
			$P_{OUT}=22\text{W}$, $R_L=3.2\Omega$		60	
		$V_{SS}=13.2\text{V}$, $f=1\text{kHz}$ $P_{OUT}=19\text{W}$, $R_L=3.2\Omega$		58	%	
Thermal Shut-down Junction Temperature	T_J	$V_{SS}=14.4\text{V}$, $R_L=4\Omega$, $f=1\text{kHz}$, $P_D=13\text{W}$		145		$^\circ\text{C}$
Output Voltage With One Side of the Speaker Shorted to Ground	V_{OSH}	$V_{SS}=14.4\text{V}$, $R_L=4\Omega$			2	V
		$V_{SS}=13.2\text{V}$, $R_L=3.2\Omega$				

■ ELECTRICAL CHARACTERISTICS(Cont.)

PARAMETER	SYMBOL	TEST CONDITIONS	MIN	TYP	MAX	UNIT
STEREO						
Supply Voltage	V_{SS}		8		18	V
Quiescent Output Voltage	V_{OUT}	$V_{SS}=14.4V$	6.6	7.2	7.8	V
		$V_{SS}=13.2V$	6	6.6	7.2	
Total Quiescent Drain Current	I_D	$V_{SS}=14.4V$		65	120	mA
		$V_{SS}=13.2V$		62	120	
Output Power (each channel) $f=1Hz$, THD=10%	P_{OUT}	$V_{SS}=14.4V$	$R_L=4\Omega$	6	6.5	W
			$R_L=3.2\Omega$	7	8	
			$R_L=2\Omega$	9	10	
		$V_{SS}=13.2V$	$R_L=3.2\Omega$	6	6.5	
			$R_L=1.6\Omega$	9	10	
		$V_{SS}=16V, R_L=2\Omega$			12	
Total Harmonic Distortion (each channel) $f=1KHz$	THD	$V_{SS}=14.4V, R_L=4\Omega,$ $P_{OUT}=50mW \sim 4W$		0.2	1	%
		$V_{SS}=14.4V, R_L=2\Omega,$ $P_{OUT}=50mW \sim 6W$		0.3	1	%
		$V_{SS}=13.2V, R_L=3.2\Omega,$ $P_{OUT}=50mW \sim 3W$		0.2	1	%
		$V_{SS}=13.2V, R_L=1.6\Omega,$ $P_{OUT}=40mW \sim 6W$		0.3	1	%
Cross Talk	C_T	$V_{SS}=14.4V, R_G=5K\Omega, V_{OUT}=4V_{RMS}, R_L=4\Omega$	$f=1KHz$		60	dB
			$f=10KHz$		45	
Input Saturation Voltage	V_{IN}		300			mV
Input Sensitivity	V_{IN}	$f=1kHz, P_{OUT}=1W$ $R_L=4\Omega$ $R_L=3.2\Omega$		6 5.5		mV
Input Resistance	R_{IN}	$f=1kHz$	70	200		k Ω
Low Frequency Roll Off (-3dB)	f_L	$R_L=2\Omega$			50	Hz
High Frequency Roll Off (-3dB)	f_H	$R_L=2\Omega$	15			kHz
Voltage Gain (open loop)	G_V	$f=1kHz$		90		dB
Voltage Gain (close loop)	G_V	$f=1kHz$	48	50	51	dB
Closed Loop Gain Matching	ΔG_V			0.5		dB
Total Input Noise Voltage	E_n	$R_G=10k\Omega$ (Note 1)		1.5	5	μV
Supply Voltage Rejection	SVR	$R_G=10k\Omega, C_3=10\mu F,$ $F_{RIPPLE}=100Hz, V_{RIPPLE}=0.5V$	35	45		dB
Efficiency	η	$V_{SS}=14.4V,$ $f=1kHz$	$P_{OUT}=6.5W, R_L=4\Omega$ $P_{OUT}=10W, R_L=2\Omega$	70 60		%
		$V_{SS}=13.2V,$ $f=1kHz$	$P_{OUT}=6.5W, R_L=3.2\Omega$ $P_{OUT}=10W, R_L=1.6\Omega$	70 60		

Note: 1. Bandwith Filter: 22Hz ~ 22kHz

TEST AND APPLICATION CIRCUIT

Bridge amplifier

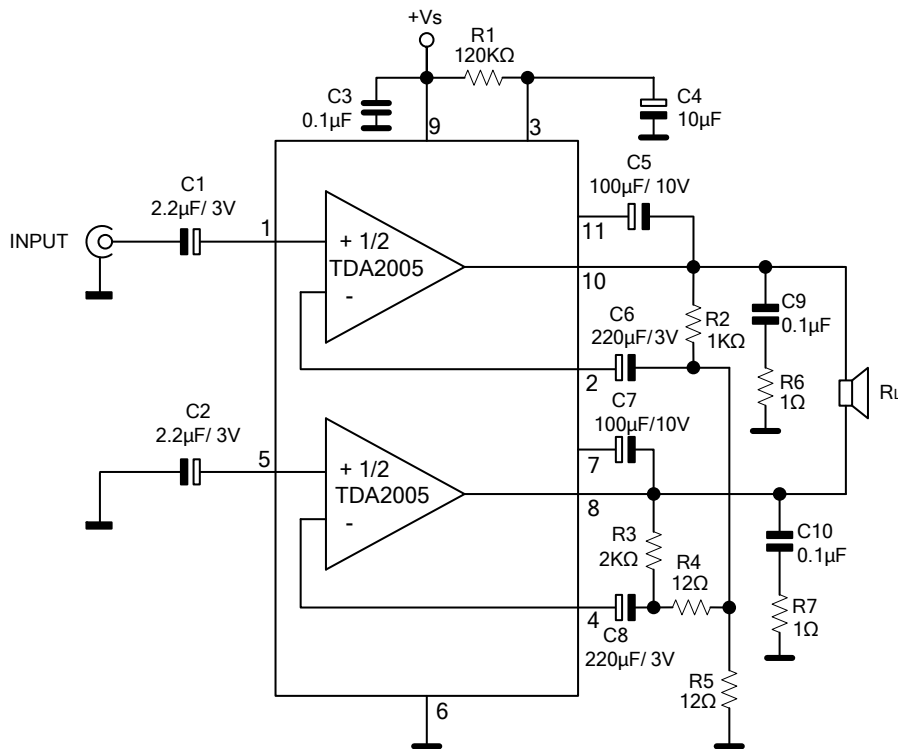

Stereo amplifier

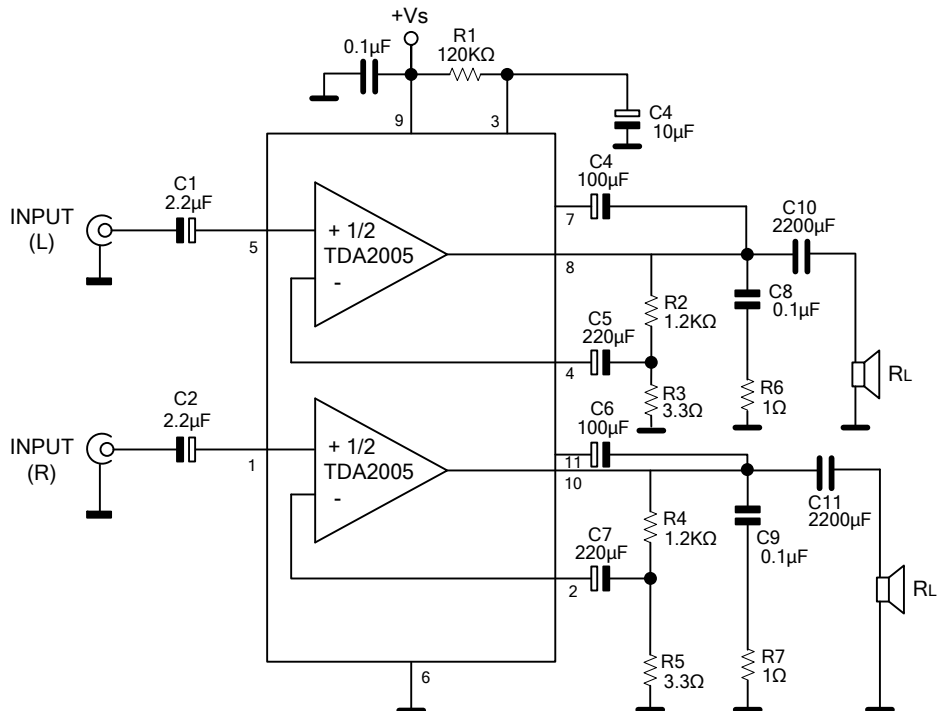

BRIDGE AMPLIFIER DESIGN

The following considerations can be useful when designing a bridge amplifier.

PARAMETER		SINGLE ENDED	BRIDGE
V _{OUT} max	Peak Output Voltage (before clipping)	$\frac{1}{2} (V_S - 2V_{CE\ sat})$	$V_S - 2V_{CE\ sat}$
I _{OUT} max	Peak Output Current (before clipping)	$\frac{1}{2} \frac{V_S - 2V_{CE\ sat}}{R_L}$	$\frac{V_S - 2V_{CE\ sat}}{R_L}$
P _{OUT} max	RMS Output Power (before clipping)	$\frac{1}{4} \frac{(V_S - 2V_{CE\ sat})^2}{2R_L}$	$\frac{(V_S - 2V_{CE\ sat})^2}{2R_L}$

Where: V_{CE sat}=output transistors saturation voltage

V_S=allowable supply voltage

R_L=load impedance

Voltage and current swings are twice for a bridge amplifier in comparison with single ended amplifier. In other words, with the same R_L the bridge configuration can deliver an output power that is four times the output power of a single ended amplifier, while, with the same max output current the bridge configuration can deliver an output power that is twice the output power of a single ended amplifier. Care must be taken when selecting V_S and R_L in order to avoid an output peak current above the absolute maximum rating.

From the expression for I_o max, assuming V_S=14.4V and V_{CE sat}=2V, the minimum load that can be driven by UTC **TDA2005** in bridge configuration is:

$$R_{L\ min} = \frac{V_S - 2V_{CE\ sat}}{I_{OUT\ max}} = \frac{14.4 - 4}{3.5} = 2.97\Omega$$

The voltage gain of the bridge configuration is given by (see Figure 3):

$$G_V = \frac{V_0}{V_1} = 1 + \frac{R_1}{\left(\frac{R_2 \cdot R_4}{R_2 + R_4}\right)} + \frac{R_3}{R_4}$$

For sufficiently high gains (40 ~ 50dB) it is possible to put R₂=R₄ and R₃=2R₁, simplifying the formula in:

$$G_V = 4 \frac{R_1}{R_2}$$

G _V (dB)	R ₁ (Ω)	R ₂ =R ₄ (Ω)	R ₃ (Ω)
40	1000	39	2000
50	1000	12	2000

Bridge Configuration

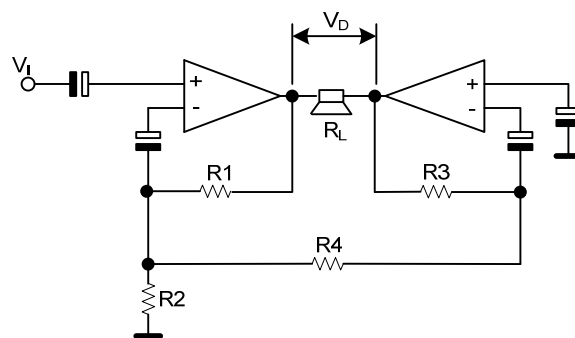

APPLICATION INFORMATION

Bridge Amplifier without Bootstrap

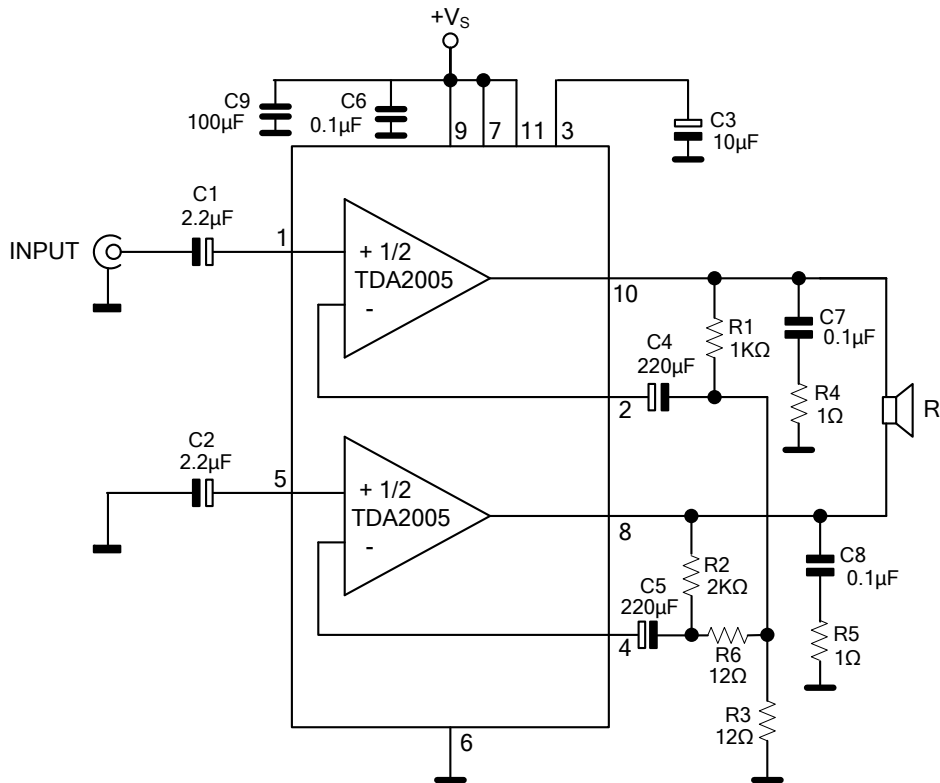

Low Cost Bridge Amplifier ($G_V=42$ dB)

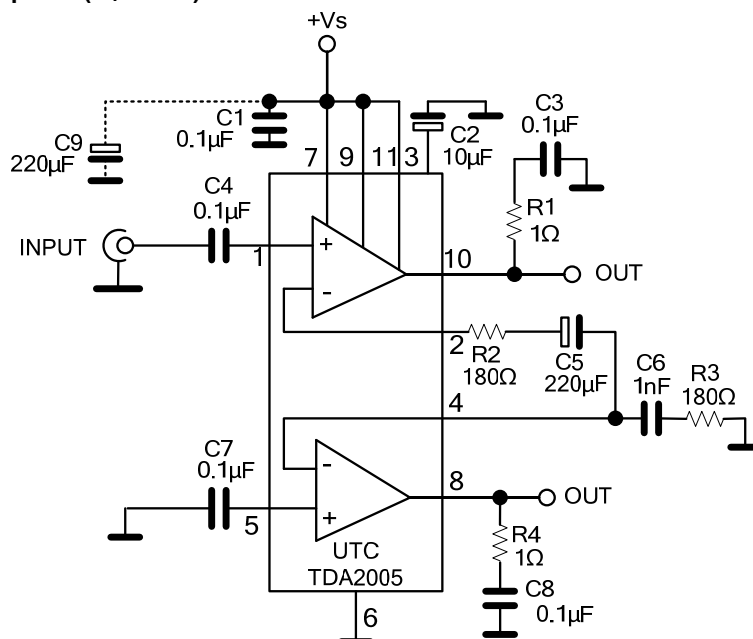

■ APPLICATION INFORMATION(Cont.)

10+10W Stereo Amplifier with Tone Balance and Loudness Control

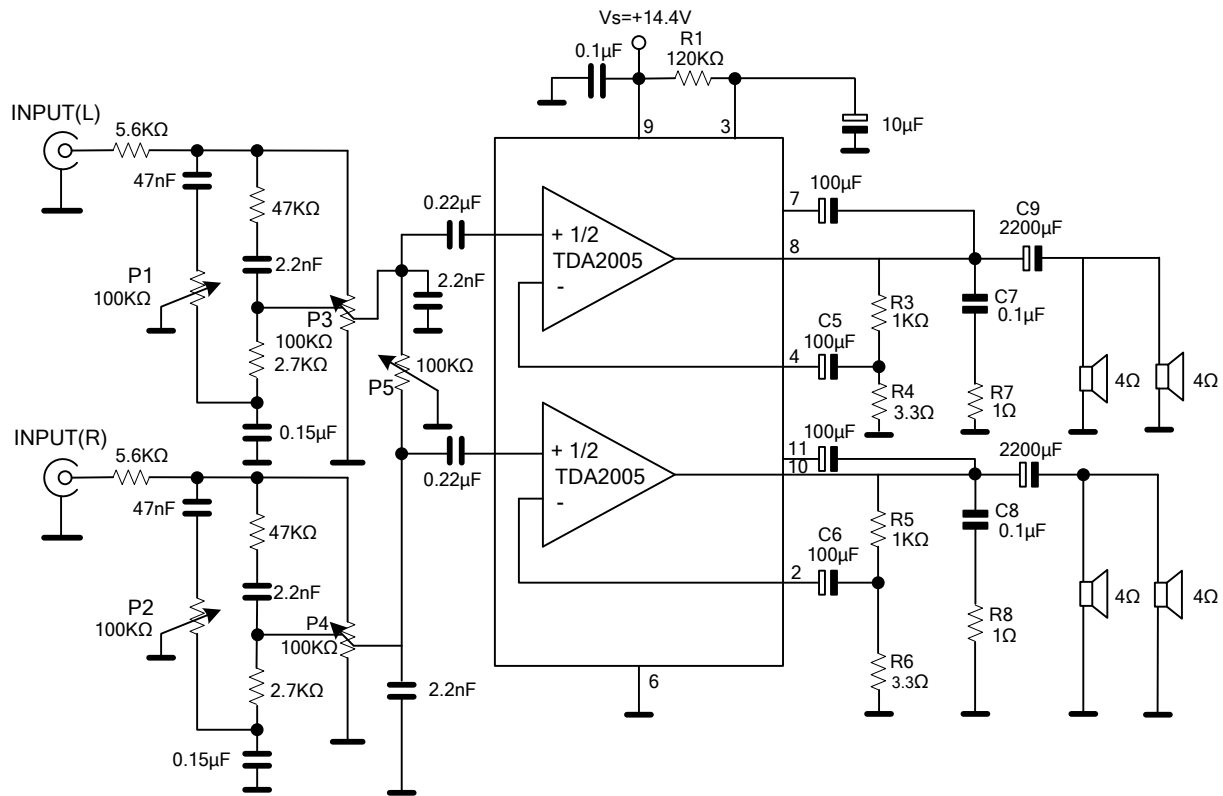

Tone Control Response (circuit of Fihure 8)

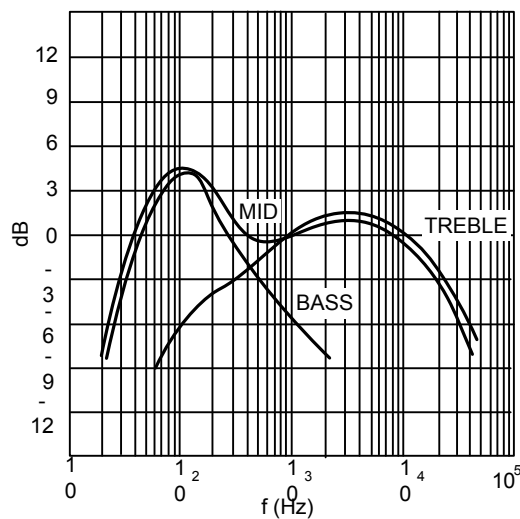

■ APPLICATION INFORMATION(Cont.)

Bridge Amplifier Circuit suited for Low-gain Applications ($G_V=34dB$)

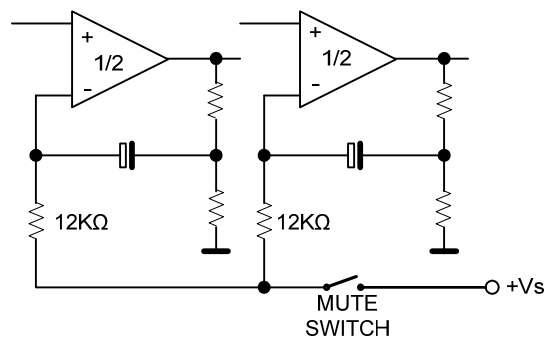
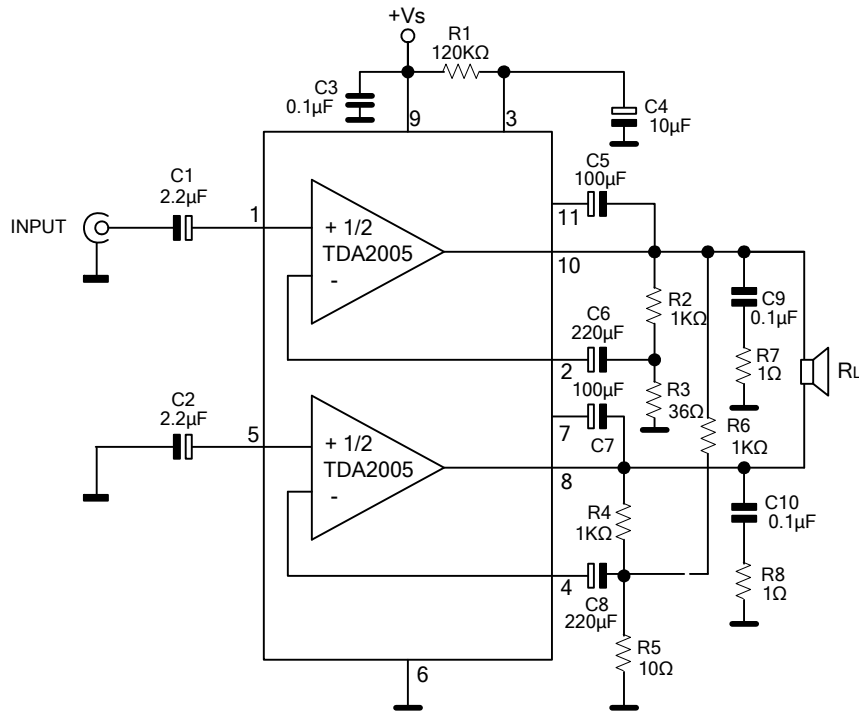

Fig. 1 Example of Muting Circuit

■ BUILT-IN PROTECTION SYSTEMS

LOAD DUMP VOLTAGE SURGE

The UTC **TDA2005** has a circuit which enables it to withstand a voltage pulse train, on pin9, of the type shown in Figure 3.

If the supply voltage peaks to more than 40V, then an LC filter must be inserted between the supply and pin9, in order to assure that the pulses at pin 9 will be held within the limits shown.

A suggested LC network is shown in Figure 2. With this network, a train of pulses with amplitude up to 120V and width of 2ms can be applied at point A. This type of protection is ON when the supply voltage (pulse or DC) exceeds 18V. For this reason the maximum operating supply voltage is 18V.

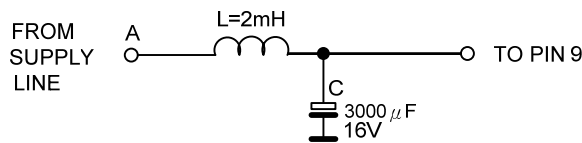

Fig. 2

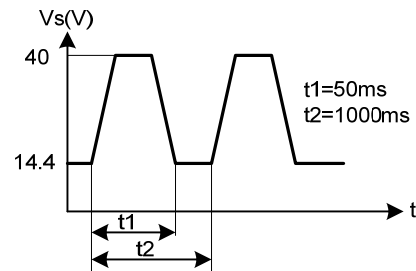

Fig. 3

SHORT CIRCUIT (AC AND DC CONDITIONS)

The UTC **TDA2005** can withstand a permanent short circuit on the output for a supply voltage up to 16V.

POLARITY INVERSION

High current (up to 10A) can be handled by the device with no damage for a longer period than the blow-out time of a quick 2A fuse (normally connected in series with the supply). This feature is added to avoid destruction, if during fitting to the car, a mistake on the connection of the supply is made.

OPEN GROUND

When the ratio is in the ON condition and the ground is accidentally opened, a standard audio amplifier will be damaged. On the UTC **TDA2005** protection diodes are included to avoid any damage.

INDUCTIVE LOAD

A protection diode is provided to allow use of the UTC **TDA2005** with inductive loads.

DC VOLTAGE

The maximum operating DC voltage for the UTC **TDA2005** is 18V.

However the device can withstand a DC voltage up to 28V with no damage. This could occur during winter if two batteries are series connected to crank the engine.

THERMAL SHUT-DOWN

The presence of a thermal limiting circuit offers the following advantages:

(1). An overload on the output (even if it is permanent), or an excessive ambient temperature can be easily withstood.

(2). The heatsink can have a smaller factor of safety compared with that of a conventional circuit. There is no device damage in the case of excessive junction temperature; all that happens is that P_o (and therefore P_D) and I_d are reduced.

The maximum allowable power dissipation depends upon the size of the external heatsink (i.e. its thermal resistance); Figure 4 shows the dissipation power as a function of ambient temperature for different thermal resistance.

LOUDSPEAKER PROTECTION

The circuit offers loudspeaker protection during short circuit for one wire to ground.

TYPICAL CHARACTERISTICS

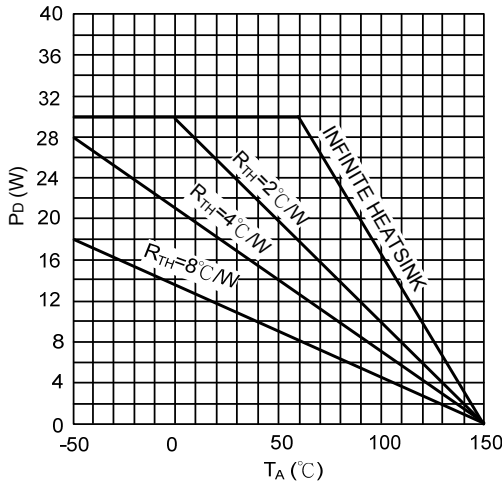

Fig. 4 Maximum Allowable Power Dissipation versus Ambient Temperature

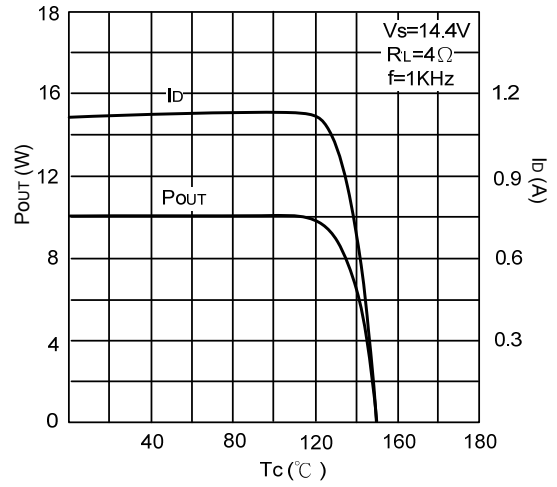

Fig. 5 Output Power and Drain Current Versus Case Temperature

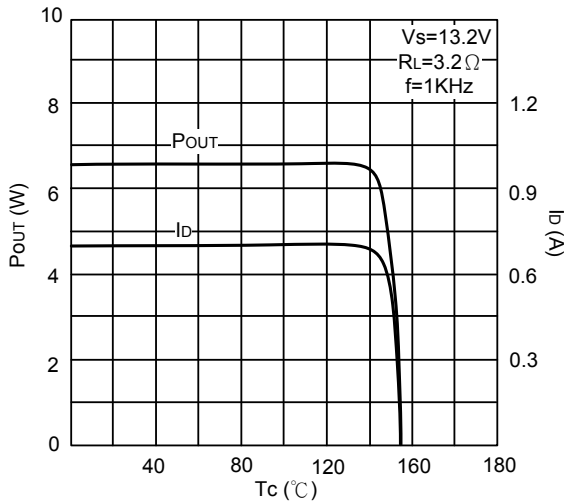

Fig. 6 Output Power and Drain Current Versus Case Temperature

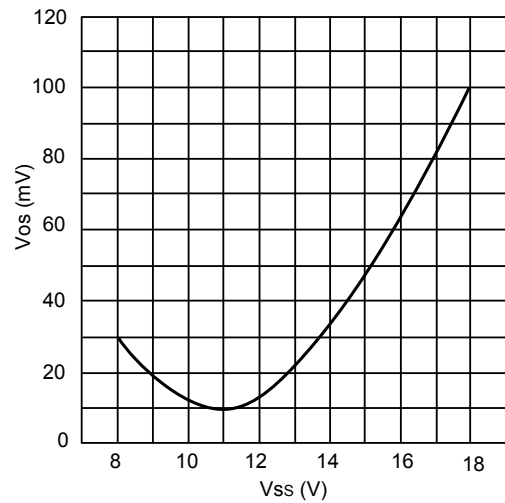

Fig. 7 Output Offset Voltage versus Supply Voltage

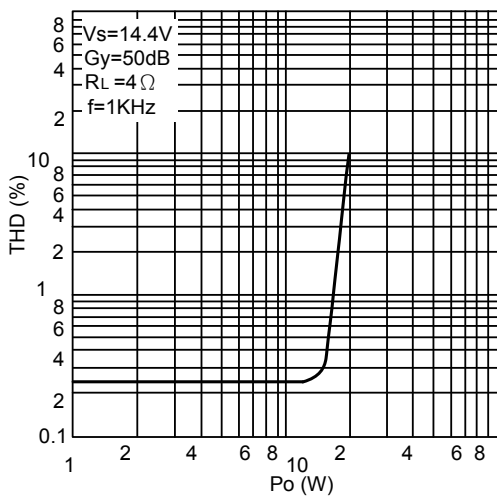

Fig. 8 Distortion versus Output Power (bridge amplifier)

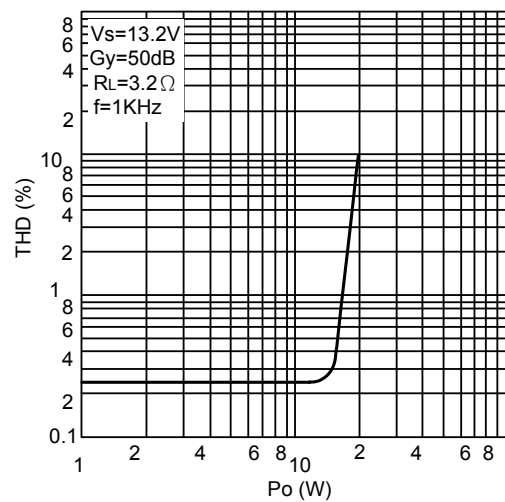

Fig. 9 Distortion versus Output Power (bridge amplifier)

TYPICAL CHARACTERISTICS (cont.)

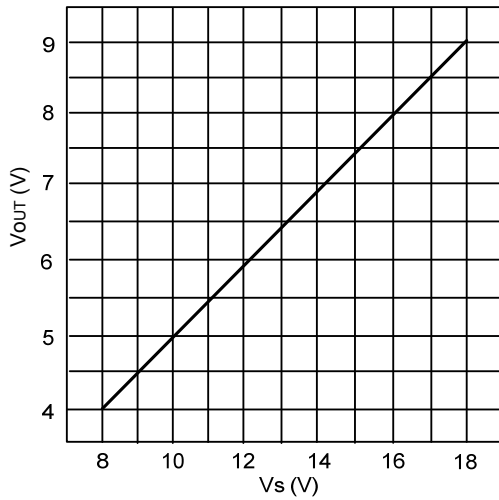

Fig. 10 Quiescent Output Voltage versus Supply Voltage (Stereo amplifier)

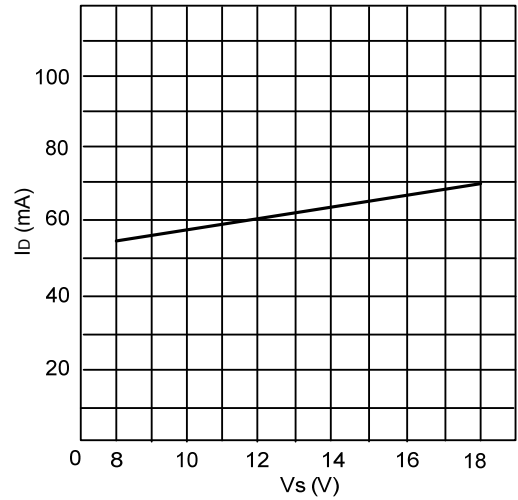

Fig. 11 Quiescent Drain Current versus Supply Voltage (Stereo amplifier)

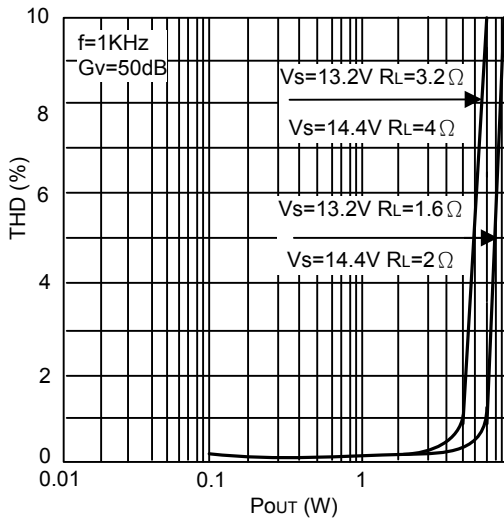

Fig. 12 Distortion versus Output Power (Stereo amplifier)

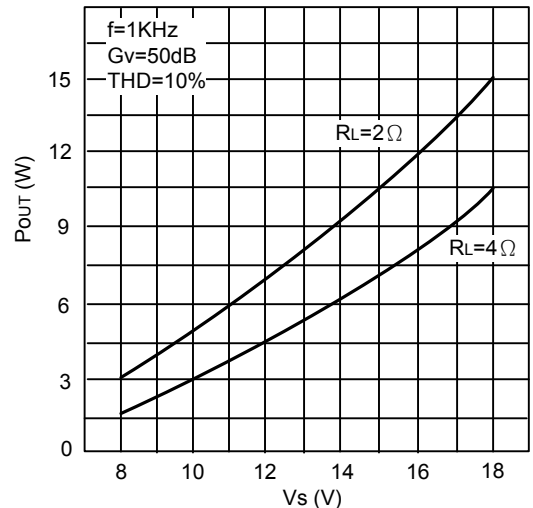

Fig. 13 Output Power versus Supply Voltage (Stereo amplifier)

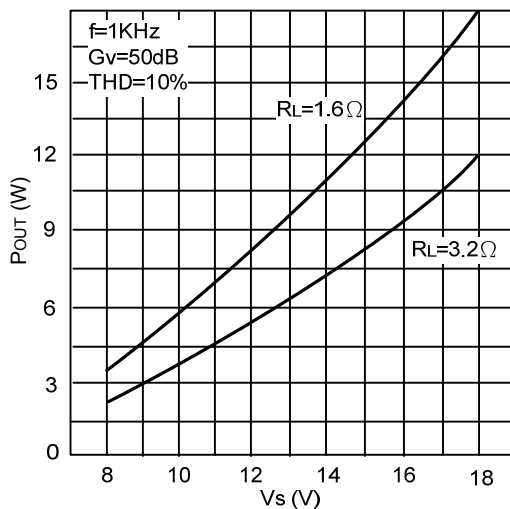

Fig. 14 Output Power versus Supply Voltage (Stereo amplifier)

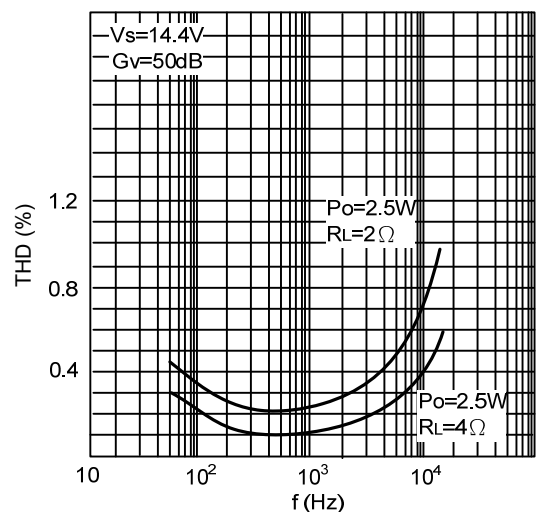

Fig. 15 Distortion versus Frequency (Stereo amplifier)

TYPICAL CHARACTERISTICS (cont.)

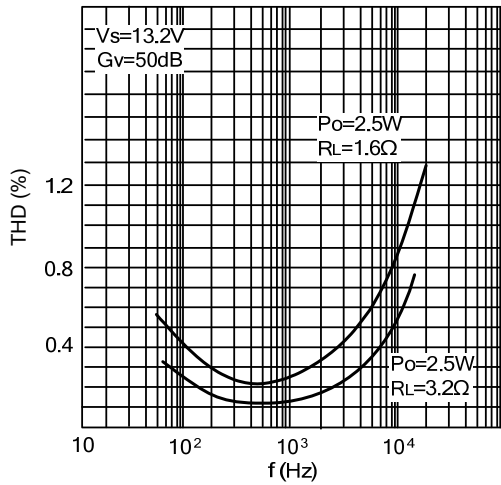

Fig. 16 Distortion versus Frequency (Stereo amplifier)

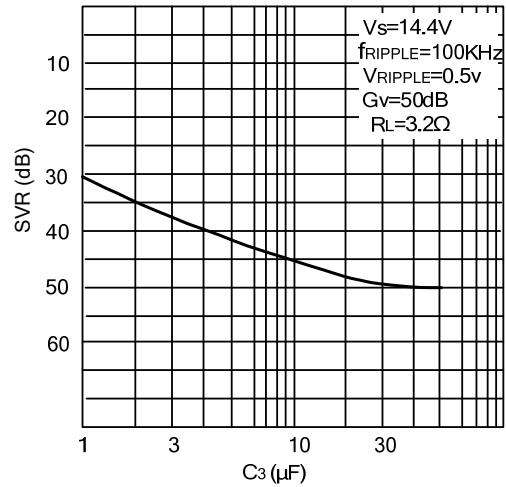

Fig. 17 Supply Voltage Rejection versus C3 (Stereo amplifier)

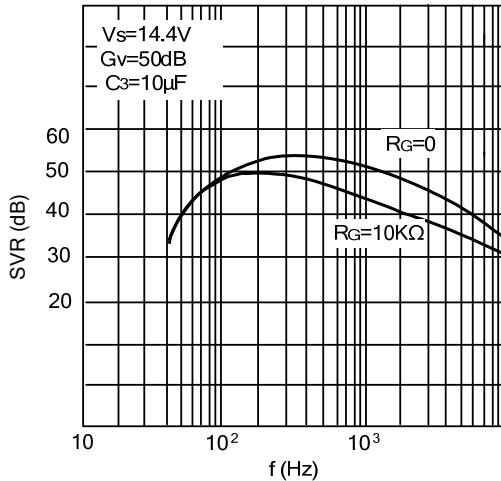

Fig. 18 Supply Voltage Rejection versus Frequency (Stereo amplifier)

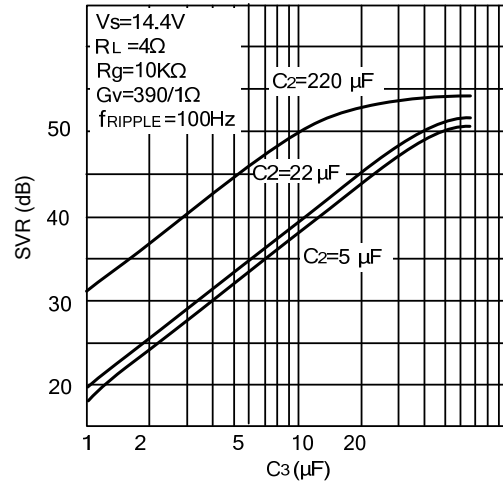

Fig. 19 Supply Voltage Rejection versus C2 and C3 (Stereo amplifier)

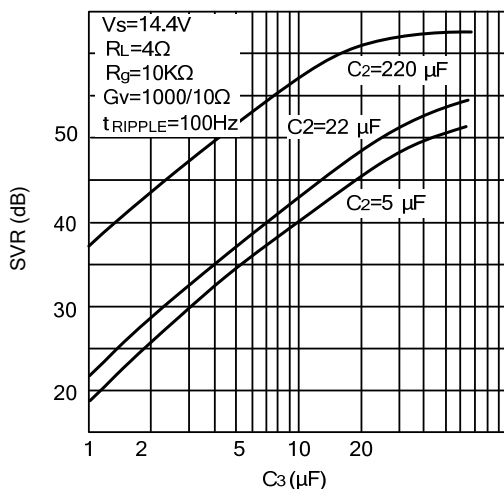

Fig. 20 Supply Voltage Rejection versus C2 and C3 (Stereo amplifier)

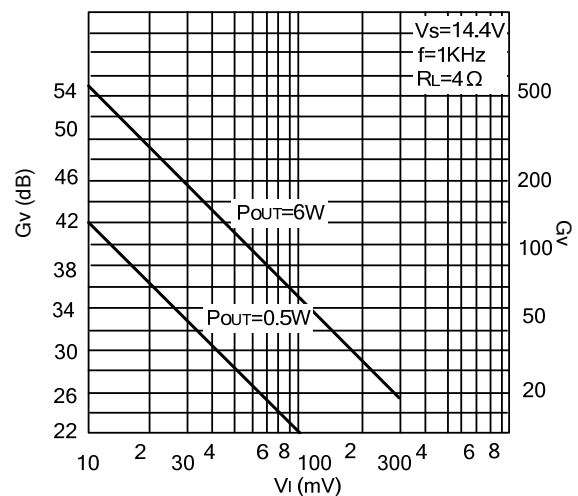

Fig. 21 Gain versus Input Sensitivity (Stereo amplifier)

■ TYPICAL CHARACTERISTICS (cont.)

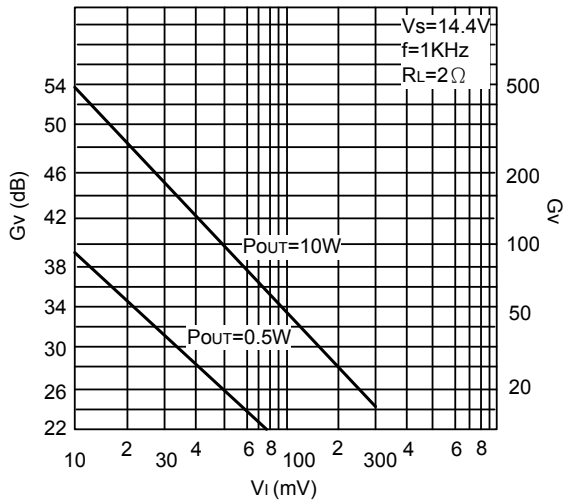

Fig. 22 Gain versus Input Sensitivity (Stereo amplifier)

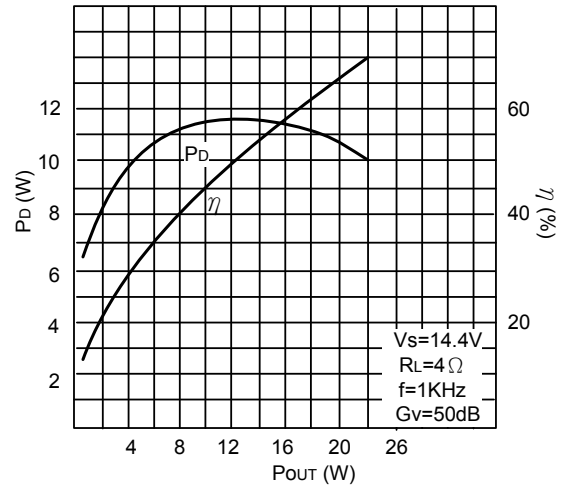

Fig. 23 Total Power Dissipation and Efficiency versus Output Power (Bridge amplifier)

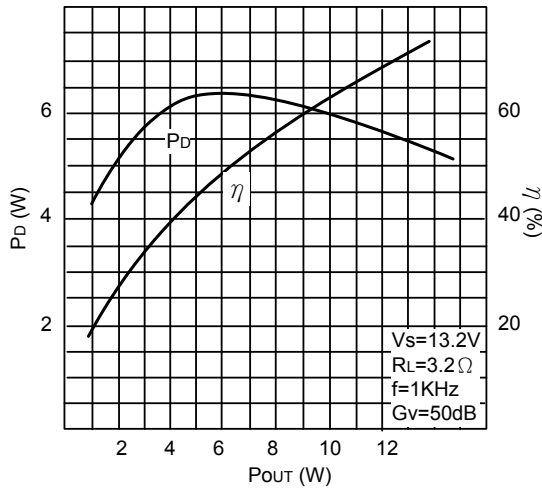

Fig. 24 Total Power Dissipation and Efficiency versus Output Power (Stereo amplifier)

UTC assumes no responsibility for equipment failures that result from using products at values that exceed, even momentarily, rated values (such as maximum ratings, operating condition ranges, or other parameters) listed in products specifications of any and all UTC products described or contained herein. UTC products are not designed for use in life support appliances, devices or systems where malfunction of these products can be reasonably expected to result in personal injury. Reproduction in whole or in part is prohibited without the prior written consent of the copyright owner. The information presented in this document does not form part of any quotation or contract, is believed to be accurate and reliable and may be changed without notice.