

# TDA2Ex SoC for Advanced Driver Assistance Systems (ADAS) 17mm Package (CBD Package)

## 1 Device Overview

### 1.1 Features

- Architecture designed for ADAS applications
- Video, image, and graphics processing support
  - Full-HD video (1920 × 1080p, 60 fps)
  - Multiple video input and video output
- Arm® Cortex®-A15 microprocessor subsystem
- C66x floating-point VLIW DSP
  - Fully object-code compatible with C67x and C64x+
  - Up to thirty-two 16 × 16-bit fixed-point multiplies per cycle
- Up to 512KB of on-chip L3 RAM
- Level 3 (L3) and Level 4 (L4) interconnects
- DDR3/DDR3L Memory Interface (EMIF) module
  - Supports up to DDR-1333 (667 MHz)
  - Up to 2GB across single chip select
- Dual Arm® Cortex®-M4 Image Processing Units (IPU)
- IVA-HD subsystem
- Display subsystem
  - Display controller With DMA engine and up to three pipelines
  - HDMI™ encoder: HDMI 1.4a and DVI 1.0 compliant
- Single-core PowerVR™ SGX544 3D GPU
- 2D-graphics accelerator (BB2D) subsystem
  - Vivante® GC320 core
- Video Processing Engine (VPE)
- One Video Input Port (VIP) module
  - Support for up to four multiplexed input ports
- General-Purpose Memory Controller (GPMC)
- Enhanced Direct Memory Access (EDMA) controller
- 2-port gigabit ethernet (GMAC)
  - Up to two external ports
- Sixteen 32-bit general-purpose timers
- 32-Bit MPU watchdog timer
- Six high-speed inter-integrated circuit (I<sup>2</sup>C) ports
- Ten configurable UART/IrDA/CIR modules
- Four Multichannel Serial Peripheral Interfaces (McSPI)
- Quad SPI Interface (QSPI)
- Eight Multichannel Audio Serial Port (McASP) modules
- SuperSpeed USB 3.0 dual-role device
- High-speed USB 2.0 dual-role device
- High-speed USB 2.0 on-the-go
- Four MultiMedia Card/Secure Digital/Secure Digital Input Output Interfaces (MMC™/SD®/SDIO)
- PCI Express® 3.0 port with integrated PHY
  - One 2-lane Gen2-compliant port
  - or Two 1-lane Gen2-compliant ports
- Dual Controller Area Network (DCAN) modules
  - CAN 2.0B protocol
- MIPI® CSI-2 camera serial interface
- Up to 186 General-Purpose I/O (GPIO) pins
- Device security features
  - Hardware crypto accelerators and DMA
  - Firewalls
  - JTAG lock
  - Secure keys
  - Secure ROM and boot
  - Customer programmable keys
- Power, reset, and clock management
- On-chip debug with CTools technology
- 28-nm CMOS technology
- 17 mm × 17 mm, 0.65-mm pitch, 538-pin BGA (CBD)



## 1.2 Applications

- LVDS or ethernet surround view
  - 3D surround view
  - Rear object detection
  - Parking assist
  - Pedestrian detection
  - Lane tracking
  - Drive recording
- Sensor Fusion – vision, radar, ultrasonic, lidar sensors
  - Object data fusion
  - Raw data fusion

## 1.3 Description

TI's new TDA2Ex System-on-Chip (SoC) is a highly optimized and scalable family of devices designed to meet the requirements of leading Advanced Driver Assistance Systems (ADAS). The TDA2Ex family enables broad ADAS applications in today's automobile by integrating an optimal mix of performance, low power, and ADAS vision analytics processing that aims to facilitate a more autonomous and collision-free driving experience.

The TDA2Ex SoC enables sophisticated embedded vision technology in today's automobile by enabling a board range of ADAS applications including park assist, surround view and sensor fusion on a single architecture.

The TDA2Ex SoC incorporates a heterogeneous, scalable architecture that includes a mix of TI's fixed and floating-point TMS320C66x digital signal processor (DSP) generation core, Arm Cortex-A15 MPCore™ and dual-Cortex-M4 processors. The integration of a video accelerator for decoding multiple video streams over an Ethernet AVB network, along with graphics accelerator for rendering virtual views, enable a 3D viewing experience. The TDA2Ex SoC also integrates a host of peripherals including multicamera interfaces (both parallel and serial, including CSI-2) to enable Ethernet or LVDS-based surround view systems, displays and GigB Ethernet AVB.

Additionally, TI provides a complete set of development tools for the Arm and DSP, including C compilers, a DSP assembly optimizer to simplify programming and scheduling, and a debugging interface for visibility into source code execution.

Cryptographic acceleration is available in all devices. All other supported security features, including support for secure boot, debug security and support for trusted execution environment are available on High-Security (HS) devices. For more information about HS devices, contact your TI representative.

The TDA2Ex ADAS processor is qualified according to the AEC-Q100 standard.

### Device Information<sup>(1)</sup>

PART NUMBER	PACKAGE	BODY SIZE
TDA2EG-17CBD	FCBGA (538)	17.0 mm x 17.0 mm

(1) For more information, see [Section 9](#), Mechanical, Packaging, and Orderable Information.

### 1.4 Functional Block Diagram

Figure 1-1 is functional block diagram for the device.

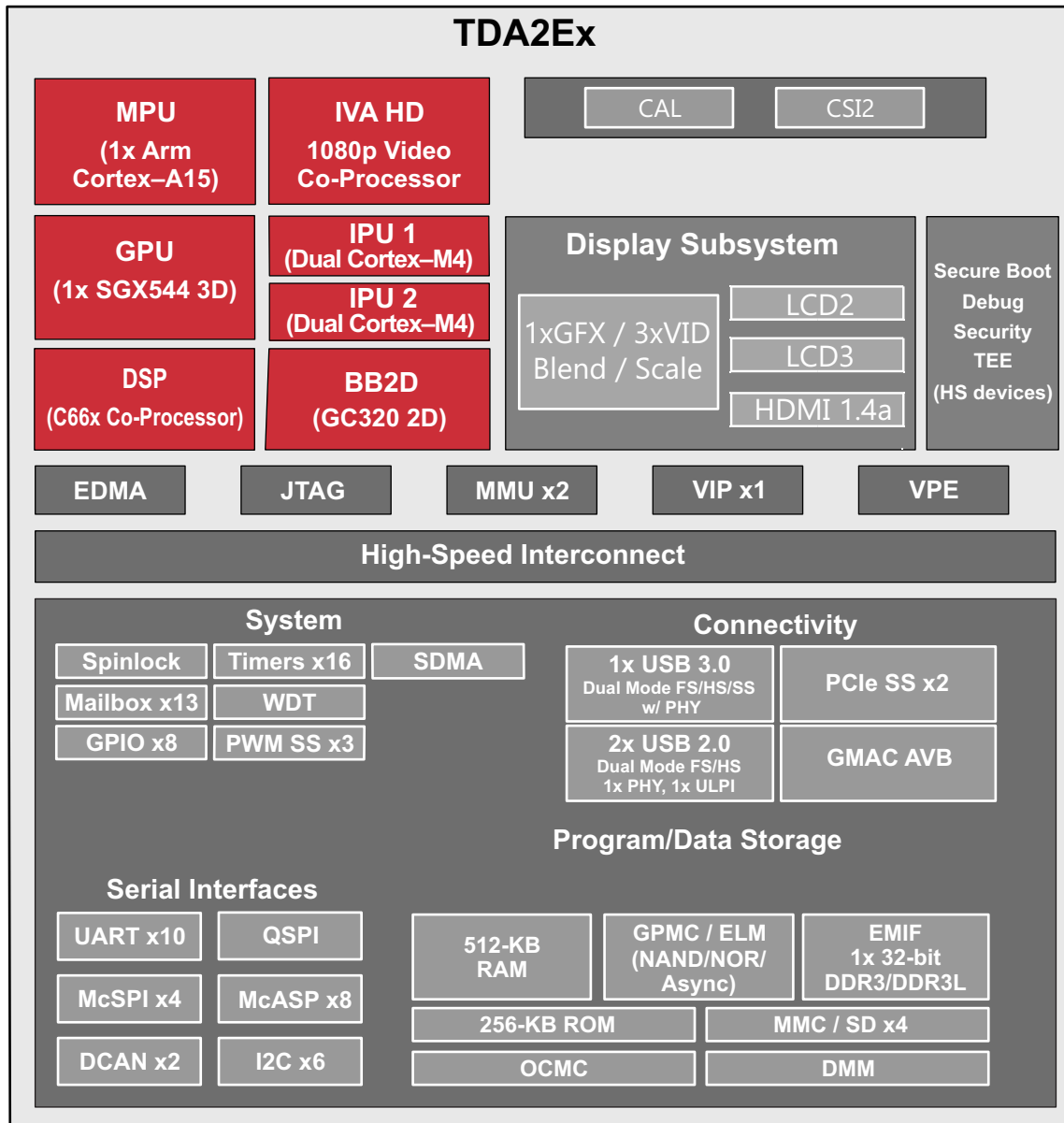

intro-001

Figure 1-1. TDA2Ex Block Diagram

## Table of Contents

<b>1</b>	<b>Device Overview</b>	<b><a href="#">1</a></b>	6.4	DSP Subsystem	<a href="#">288</a>
1.1	Features	<a href="#">1</a>	6.5	IVA	<a href="#">292</a>
1.2	Applications	<a href="#">2</a>	6.6	IPU	<a href="#">292</a>
1.3	Description	<a href="#">2</a>	6.7	GPU	<a href="#">293</a>
1.4	Functional Block Diagram	<a href="#">3</a>	6.8	BB2D	<a href="#">295</a>
<b>2</b>	<b>Revision History</b>	<b><a href="#">5</a></b>	6.9	Memory Subsystem	<a href="#">297</a>
<b>3</b>	<b>Device Comparison</b>	<b><a href="#">6</a></b>	6.10	Interprocessor Communication	<a href="#">300</a>
3.1	Related Products	<a href="#">7</a>	6.11	Interrupt Controller	<a href="#">301</a>
<b>4</b>	<b>Terminal Configuration and Functions</b>	<b><a href="#">8</a></b>	6.12	EDMA	<a href="#">302</a>
4.1	Pin Diagram	<a href="#">8</a>	6.13	Peripherals	<a href="#">303</a>
4.2	Pin Attributes	<a href="#">8</a>	6.14	On-chip Debug	<a href="#">320</a>
4.3	Signal Descriptions	<a href="#">56</a>	<b>7</b>	<b>Applications, Implementation, and Layout</b>	<b><a href="#">323</a></b>
4.4	Pin Multiplexing	<a href="#">88</a>	7.1	Introduction	<a href="#">323</a>
4.5	Connections for Unused Pins	<a href="#">101</a>	7.2	Power Optimizations	<a href="#">324</a>
<b>5</b>	<b>Specifications</b>	<b><a href="#">102</a></b>	7.3	Core Power Domains	<a href="#">335</a>
5.1	Absolute Maximum Ratings	<a href="#">103</a>	7.4	Single-Ended Interfaces	<a href="#">346</a>
5.2	ESD Ratings	<a href="#">104</a>	7.5	Differential Interfaces	<a href="#">348</a>
5.3	Power on Hour (POH) Limits	<a href="#">104</a>	7.6	Clock Routing Guidelines	<a href="#">367</a>
5.4	Recommended Operating Conditions	<a href="#">104</a>	7.7	DDR3 Board Design and Layout Guidelines	<a href="#">367</a>
5.5	Operating Performance Points	<a href="#">107</a>	<b>8</b>	<b>Device and Documentation Support</b>	<b><a href="#">391</a></b>
5.6	Power Consumption Summary	<a href="#">127</a>	8.1	Device Nomenclature	<a href="#">391</a>
5.7	Electrical Characteristics	<a href="#">127</a>	8.2	Tools and Software	<a href="#">393</a>
5.8	VPP Specifications for One-Time Programmable (OTP) eFuses	<a href="#">134</a>	8.3	Documentation Support	<a href="#">394</a>
5.9	Thermal Resistance Characteristics for CBD Package	<a href="#">135</a>	8.4	Related Links	<a href="#">394</a>
5.10	Timing Requirements and Switching Characteristics	<a href="#">137</a>	8.5	Support Resources	<a href="#">394</a>
<b>6</b>	<b>Detailed Description</b>	<b><a href="#">283</a></b>	8.6	Trademarks	<a href="#">394</a>
6.1	Description	<a href="#">283</a>	8.7	Electrostatic Discharge Caution	<a href="#">395</a>
6.2	Functional Block Diagram	<a href="#">283</a>	8.8	Glossary	<a href="#">395</a>
6.3	MPU	<a href="#">285</a>	<b>9</b>	<b>Mechanical, Packaging, and Orderable Information</b>	<b><a href="#">396</a></b>
			9.1	Packaging Information	<a href="#">396</a>

---

## 2 Revision History

---

Changes from May 16, 2019 to November 15, 2019 (from F Revision (May 2019) to G Revision)	Page
<ul style="list-style-type: none"><li>Added reminders to disable unused pulls and RX pads in <a href="#">Section 4.2, Pin Attributes</a> .....</li></ul>	<a href="#">9</a>

---

### 3 Device Comparison

Table 3-1 shows a comparison between devices, highlighting the differences.

**Table 3-1. Device Comparison<sup>(3)</sup>**

FEATURES		DEVICE	
		TDA2EGx	
<b>Features</b>			
CTRL_WKUP_STD_FUSE_DIE_ID_2 [31:24] Base PN register bitfield value <sup>(2)(3)</sup>		20 (0x14)	
<b>Processors/Accelerators</b>			
Speed Grades		H, D	
Arm Single Cortex-A15 Microprocessor (MPU) Subsystem	MPU core 0	Yes	
C66x VLIW DSP	DSP1	Yes	
BitBLT 2D Hardware Acceleration Engine (BB2D)	BB2D	Yes	
Display Subsystem	VOUT1	No	
	VOUT2	Yes	
	VOUT3	Yes	
	HDMI	Yes	
Dual Arm Cortex-M4 Image Processing Unit (IPU)	IPU1	Yes	
	IPU2 <sup>(1)</sup>	Yes	
Image Video Accelerator (IVA)	IVA	Yes	
SGX544 Single-Core 3D Graphics Processing Unit (GPU)	GPU	Yes	
Video Input Port (VIP)	VIP1	vin1a	Yes
		vin1b	Yes
		vin2a	Yes
		vin2b	Yes
Video Processing Engine (VPE)	VPE	Yes	
<b>Program/Data Storage</b>			
On-Chip Shared Memory (RAM)	OCMC_RAM1	512KB	
General-Purpose Memory Controller (GPMC)	GPMC	Yes	
DDR3/DDR3L Memory Controller	EMIF1	up to 2GB	
	SECCDED/ECC	No	
Dynamic Memory Manager (DMM)	DMM	Yes	
<b>Peripherals</b>			
Controller Area Network (DCAN) Interface	DCAN1	Yes	
	DCAN2	Yes	
Enhanced DMA (EDMA)	EDMA	Yes	
System DMA (DMA_SYSTEM)	DMA_SYSTEM	Yes	
Ethernet Subsystem (Ethernet SS)	GMAC_SW[0]	MII, RMII, or RGMII	
	GMAC_SW[1]	MII, RMII, or RGMII	
General-Purpose I/O (GPIO)	GPIO	Up to 186	
Inter-Integrated Circuit Interface (I <sup>2</sup> C)	I2C	6	
System Mailbox Module	MAILBOX	13	
Camera Adaptation Layer (CAL) Camera Serial Interface 2 (CSI2)	CSI2_0	1 CLK + 2 Data	
	CSI2_1	No	

**Table 3-1. Device Comparison<sup>(3)</sup> (continued)**

FEATURES		DEVICE
		TDA2EGx
Multichannel Audio Serial Port (McASP)	McASP1	16 serializers
	McASP2	16 serializers
	McASP3	4 serializers
	McASP4	4 serializers
	McASP5	4 serializers
	McASP6	4 serializers
	McASP7	4 serializers
	McASP8	2 serializers
MultiMedia Card/Secure Digital/Secure Digital Input Output Interface (MMC/SD/SDIO)	MMC1	1x UHSI 4b
	MMC2	1x eMMC™ 8b
	MMC3	1x SDIO 8b
	MMC4	1x SDIO 4b
PCI Express 3.0 Port with Integrated PHY	PCIe_SS1	Up to two lanes (second lane shared with PCIe_SS2 and USB1)
	PCIe_SS2	Single lane (shared with PCIe_SS1 and USB1)
Serial Advanced Technology Attachment (SATA)	SATA	No
Real-Time Clock Subsystem (RTCSS)	RTCSS	No
Multichannel Serial Peripheral Interface (McSPI)	McSPI	4
Quad SPI (QSPI)	QSPI	Yes
Spinlock Module	SPINLOCK	Yes
Timers, General-Purpose	TIMERS GP	16
Timer, Watchdog	WD TIMER	Yes
Pulse-Width Modulation Subsystem (PWMSS)	PWMSS1	Yes
	PWMSS2	Yes
	PWMSS3	Yes
Universal Asynchronous Receiver/Transmitter (UART)	UART	10
Universal Serial Bus (USB3.0)	USB1 (Super- Speed, Dual-Role- Device [DRD])	Yes
Universal Serial Bus (USB2.0)	USB2 (High- Speed, Dual-Role- Device [DRD], with embedded HS PHY)	Yes
	USB3 (High- Speed, OTG2.0, with ULPI)	Yes
	USB4 (High- Speed, OTG2.0, with ULPI)	No

(1) IPU2 subsystem is dedicated to IVA support and is not available for other processing.

(2) For more details about the CTRL\_WKUP\_STD\_FUSE\_DIE\_ID\_2 register and Base PN bitfield, see the device TRM.

(3) X777 base part number with X speed grade indicator is the part number for the superset device. Software should constrain the features and speed used to match the intended production device. The Base PN register bitfield value is 0x4F.

### 3.1 Related Products

#### Automotive Processors

**TDAx ADAS SoCs** TI's TDAx Driver Assistance System-on-Chip (SoC) family offers scalable and open solutions and a common hardware and software architecture for Advanced Driver Assistance Systems (ADAS) applications including camera-based front (mono and stereo), rear, surround view and night vision systems, and mid- and long-range radar and sensor fusion systems.

**Companion Products for TDA2** Review products that are frequently purchased or used in conjunction with this product.

## 4 Terminal Configuration and Functions

### 4.1 Pin Diagram

Figure 4-1 shows the ball locations for the 538 plastic ball grid array (PBGA) package and is used in conjunction with Table 4-1 through Table 4-26 to locate signal names and ball grid numbers.

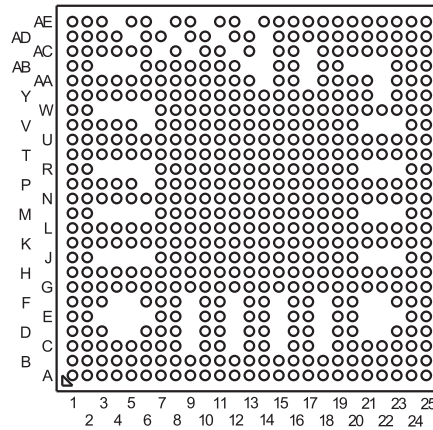

Figure 4-1. CBD S-PBGA-N538 Package (Bottom View)

#### NOTE

The following bottom balls are not pinned out: AE4 / AE7 / AE10 / AE13 / AD5 / AD8 / AD11 / AD14 / AC7 / AC9 / AC12 / AC14 / AC17 / AB3 / AB4 / AB5 / AB13 / AB14 / AB17 / AB20 / AB21 / AB22 / AA14 / AA17 / AA22 / Y22 / W3 / W4 / W5 / W6 / V6 / V21 / V22 / V23 / R3 / R4 / R5 / R6 / R21 / R22 / R23 / P6 / M3 / M4 / M5 / M6 / M21 / M22 / M23 / J3 / J4 / J5 / J6 / J21 / J22 / J23 / F4 / F5 / F9 / F12 / F15 / F18 / F21 / F22 / E3 / E4 / E5 / E6 / E9 / E12 / E15 / E18 / E21 / E22 / E23 / D4 / D5 / D9 / D12 / D15 / D18 / D21 / D22 / C9 / C12 / C15 / C18.

These balls do not exist on the package.

### 4.2 Pin Attributes

Table 4-1 describes the terminal characteristics and the signals multiplexed on each ball. The following list describes the table column headers:

1. **BALL NUMBER:** This column lists ball numbers on the bottom side associated with each signal on the bottom.
2. **BALL NAME:** This column lists mechanical name from package device (name is taken from muxmode 0).
3. **SIGNAL NAME:** This column lists names of signals multiplexed on each ball (also notice that the name of the ball is the signal name in muxmode 0).

#### NOTE

Table 4-1 does not take into account the subsystem multiplexing signals. Subsystem multiplexing signals are described in Section 4.3, *Signal Descriptions*.

#### NOTE

In driver off mode, the buffer is configured in high-impedance.



**NOTE**

In some cases [Table 4-1](#) may present more than one signal name per muxmode for the same ball. First signal in the list is the dominant function as selected via CTRL\_CORE\_PAD\_\* register.

All other signals are virtual functions that present alternate multiplexing options. This virtual functions are controlled via CTRL\_CORE\_ALT\_SELECT\_MUX or CTRL\_CORE\_VIP\_MUX\_SELECT register. For more information on how to use this options, please refer to Device TRM, Chapter *Control Module*, Section *Pad Configuration Registers*.

**4. MUXMODE:** Multiplexing mode number:

- a. MUXMODE 0 is the primary mode; this means that when MUXMODE=0 is set, the function mapped on the pin corresponds to the name of the pin. The primary muxmode is not necessarily the default muxmode.

**NOTE**

The default mode is the mode at the release of the reset; also see the RESET REL. MUXMODE column.

- b. MUXMODE 1 through 15 are possible muxmodes for alternate functions. On each pin, some muxmodes are effectively used for alternate functions, while some muxmodes are not used. Only MUXMODE values which correspond to defined functions should be used.
- c. An empty box means Not Applicable.

**5. TYPE:** Signal type and direction:

- I = Input
- O = Output
- IO = Input or Output
- D = Open drain
- DS = Differential Signaling
- A = Analog
- PWR = Power
- GND = Ground
- CAP = LDO Capacitor

**NOTE**

The RX buffer within the pad logic should be disabled on all pins that are not being used as an input. For more information, see the *Control Module / Control Module Functional Description / PAD Functional Multiplexing and Configuration* section in the device TRM.

**6. BALL RESET STATE:** The state of the terminal at power-on reset:

- drive 0 (OFF): The buffer drives  $V_{OL}$  (pulldown or pullup resistor not activated)
- drive 1 (OFF): The buffer drives  $V_{OH}$  (pulldown or pullup resistor not activated)
- OFF: High-impedance
- PD: High-impedance with an active pulldown resistor
- PU: High-impedance with an active pullup resistor
- An empty box means Not Applicable

**NOTE**

Designs that contain pullup or pulldown resistors, either on the board or in attached devices that oppose internal pullup or pulldown resistors, that are active while the device is held in reset, must not remain in reset for long periods of time.

**7. BALL RESET REL. STATE:** The state of the terminal at the deactivation of the rstoutn signal (also

mapped to the PRCM SYS\_WARM\_OUT\_RST signal)

- drive 0 (OFF): The buffer drives  $V_{OL}$  (pulldown or pullup resistor not activated)
- drive clk (OFF): The buffer drives a toggling clock (pulldown or pullup resistor not activated)
- drive 1 (OFF): The buffer drives  $V_{OH}$  (pulldown or pullup resistor not activated)
- OFF: High-impedance
- PD: High-impedance with an active pulldown resistor
- PU: High-impedance with an active pullup resistor
- An empty box means Not Applicable

---

#### NOTE

For more information on the CORE\_PWRON\_RET\_RST reset signal and its reset sources, see the Power, Reset, and Clock Management / PRCM Reset Management Functional Description section of the Device TRM.

- 
8. **BALL RESET REL. MUXMODE:** This muxmode is automatically configured at the release of the rstoutn signal (also mapped to the PRCM SYS\_WARM\_OUT\_RST signal).  
An empty box means Not Applicable.
  9. **IO VOLTAGE VALUE:** This column describes the IO voltage value (the corresponding power supply).  
An empty box means Not Applicable.
  10. **POWER:** The voltage supply that powers the terminal IO buffers.  
An empty box means Not Applicable.
  11. **HYS:** Indicates if the input buffer is with hysteresis:
    - Yes: With hysteresis
    - No: Without hysteresis
    - An empty box: Not Applicable

---

#### NOTE

For more information, see the hysteresis values in [Section 5.7, Electrical Characteristics](#).

- 
12. **BUFFER TYPE:** Drive strength of the associated output buffer.  
An empty box means Not Applicable.

---

#### NOTE

For programmable buffer strength:

- The default value is given in [Table 4-1](#).
- A note describes all possible values according to the selected muxmode.

- 
13. **PULLUP / PULLDOWN TYPE:** Denotes the presence of an internal pullup or pulldown resistor. Pullup and pulldown resistors can be enabled or disabled via software.
    - PU: Internal pullup
    - PD: Internal pulldown
    - PU/PD: Internal pullup and pulldown
    - PUX/PDY: Programmable internal pullup and pulldown
    - PDY: Programmable internal pulldown
    - An empty box means No pull

---

#### NOTE

Internal pullup or pulldown resistors must be disabled when opposed by an external pullup or pulldown resistor on the board or within an attached device.

- 
14. **DSIS:** The deselected input state (DSIS) indicates the state driven on the peripheral input (logic "0" or logic "1") when the peripheral pin function is not selected by any of the PINCNTLx registers.

- 0: Logic 0 driven on the peripheral's input signal port.
- 1: Logic 1 driven on the peripheral's input signal port.
- blank: Pin state driven on the peripheral's input signal port.

---

**NOTE**

Configuring two pins to the same input signal is not supported as it can yield unexpected results. This can be easily prevented with the proper software configuration (Hi-Z mode is not an input signal).

---

---

**NOTE**

When a pad is set into a multiplexing mode which is not defined by pin multiplexing, that pad's behavior is undefined. This should be avoided.

---

---

**NOTE**

Some of the EMIF1 signals have an additional state change at the release of porz. The state that the signals change to at the release of porz is as follows:

drive 0 (OFF) for: ddr1\_ck, ddr1\_odt[0], ddr1\_rst.

drive 1 (OFF) for: ddr1\_casn, ddr1\_rasn, ddr1\_wen, ddr1\_nck, ddr1\_ba[2:0], ddr1\_a[15:0], ddr1\_csn[0], ddr1\_cke, ddr1\_dqm[3:0]

---

---

**NOTE**

Dual rank support is not available on this device, but signal names are retained for consistency with the TDA2xx family of devices

---

---

Table 4-1. Pin Attributes<sup>(1)</sup>

BALL NUMBER [1]	BALL NAME [2]	SIGNAL NAME [3]	MUXMODE [4]	TYPE [5]	BALL RESET STATE [6]	BALL RESET REL. STATE [7]	BALL RESET REL. MUXMODE [8]	I/O VOLTAGE VALUE [9]	POWER [10]	HYS [11]	BUFFER TYPE [12]	PULL UP/DOWN TYPE [13]	DSIS [14]
F8	cap_vbbldo_dsp	cap_vbbldo_dsp		CAP									
T7	cap_vbbldo_gpu	cap_vbbldo_gpu		CAP									
G14	cap_vbbldo_iva	cap_vbbldo_iva		CAP									
F17	cap_vbbldo_mpu	cap_vbbldo_mpu		CAP									
U20	cap_vddram_core1	cap_vddram_core1		CAP									
K7	cap_vddram_core3	cap_vddram_core3		CAP									
G19	cap_vddram_core4	cap_vddram_core4		CAP									
L7	cap_vddram_dsp	cap_vddram_dsp		CAP									
V7	cap_vddram_gpu	cap_vddram_gpu		CAP									
G12	cap_vddram_iva	cap_vddram_iva		CAP									
G18	cap_vddram_mpu	cap_vddram_mpu		CAP									
AC1	csi2_0_dx0	csi2_0_dx0	0	I				1.8		Yes	LVC MOS CSI2	PU/PD	
AD1	csi2_0_dx1	csi2_0_dx1	0	I				1.8		Yes	LVC MOS CSI2	PU/PD	
AE2	csi2_0_dx2	csi2_0_dx2	0	I				1.8		Yes	LVC MOS CSI2	PU/PD	
AB2	csi2_0_dy0	csi2_0_dy0	0	I				1.8		Yes	LVC MOS CSI2	PU/PD	
AC2	csi2_0_dy1	csi2_0_dy1	0	I				1.8		Yes	LVC MOS CSI2	PU/PD	
AD2	csi2_0_dy2	csi2_0_dy2	0	I				1.8		Yes	LVC MOS CSI2	PU/PD	
H23	dcan1_rx	dcan1_rx	0	IO	PU	PU	15	1.8/3.3	vddshv3	Yes	Dual Voltage LVC MOS	PU/PD	1
		uart8_txd	2	O									
		mmc2_sdwp	3	I									0
		hdmi1_cec	6	IO									
		gpio1_15	14	IO									
		Driver off	15	I									
H22	dcan1_tx	dcan1_tx	0	IO	PU	PU	15	1.8/3.3	vddshv3	Yes	Dual Voltage LVC MOS	PU/PD	1
		uart8_rxd	2	I									1
		mmc2_sdcd	3	I									1
		hdmi1_hpd	6	IO									
		gpio1_14	14	IO									
		Driver off	15	I									
AC18	ddr1_a0	ddr1_a0	0	O	PD	drive 1 (OFF)		1.35/1.5	vdds_ddr1	No	LVC MOS DDR	PUx/PDy	
AE19	ddr1_a1	ddr1_a1	0	O	PD	drive 1 (OFF)		1.35/1.5	vdds_ddr1	No	LVC MOS DDR	PUx/PDy	

Table 4-1. Pin Attributes<sup>(1)</sup> (continued)

BALL NUMBER [1]	BALL NAME [2]	SIGNAL NAME [3]	MUXMODE [4]	TYPE [5]	BALL RESET STATE [6]	BALL RESET REL. STATE [7]	BALL RESET REL. MUXMODE [8]	I/O VOLTAGE VALUE [9]	POWER [10]	HYS [11]	BUFFER TYPE [12]	PULL UP/DOWN TYPE [13]	DSIS [14]
AD19	ddr1_a2	ddr1_a2	0	O	PD	drive 1 (OFF)		1.35/1.5	vdds_ddr1	No	LVC MOS DDR	PUx/PDy	
AB19	ddr1_a3	ddr1_a3	0	O	PD	drive 1 (OFF)		1.35/1.5	vdds_ddr1	No	LVC MOS DDR	PUx/PDy	
AD20	ddr1_a4	ddr1_a4	0	O	PD	drive 1 (OFF)		1.35/1.5	vdds_ddr1	No	LVC MOS DDR	PUx/PDy	
AE20	ddr1_a5	ddr1_a5	0	O	PD	drive 1 (OFF)		1.35/1.5	vdds_ddr1	No	LVC MOS DDR	PUx/PDy	
AA18	ddr1_a6	ddr1_a6	0	O	PD	drive 1 (OFF)		1.35/1.5	vdds_ddr1	No	LVC MOS DDR	PUx/PDy	
AA20	ddr1_a7	ddr1_a7	0	O	PD	drive 1 (OFF)		1.35/1.5	vdds_ddr1	No	LVC MOS DDR	PUx/PDy	
Y21	ddr1_a8	ddr1_a8	0	O	PD	drive 1 (OFF)		1.35/1.5	vdds_ddr1	No	LVC MOS DDR	PUx/PDy	
AC20	ddr1_a9	ddr1_a9	0	O	PD	drive 1 (OFF)		1.35/1.5	vdds_ddr1	No	LVC MOS DDR	PUx/PDy	
AA21	ddr1_a10	ddr1_a10	0	O	PD	drive 1 (OFF)		1.35/1.5	vdds_ddr1	No	LVC MOS DDR	PUx/PDy	
AC21	ddr1_a11	ddr1_a11	0	O	PD	drive 1 (OFF)		1.35/1.5	vdds_ddr1	No	LVC MOS DDR	PUx/PDy	
AC22	ddr1_a12	ddr1_a12	0	O	PD	drive 1 (OFF)		1.35/1.5	vdds_ddr1	No	LVC MOS DDR	PUx/PDy	
AC15	ddr1_a13	ddr1_a13	0	O	PD	drive 1 (OFF)		1.35/1.5	vdds_ddr1	No	LVC MOS DDR	PUx/PDy	
AB15	ddr1_a14	ddr1_a14	0	O	PD	drive 1 (OFF)		1.35/1.5	vdds_ddr1	No	LVC MOS DDR	PUx/PDy	
AC16	ddr1_a15	ddr1_a15	0	O	PD	drive 1 (OFF)		1.35/1.5	vdds_ddr1	No	LVC MOS DDR	PUx/PDy	
AE16	ddr1_ba0	ddr1_ba0	0	O	PU	drive 1 (OFF)		1.35/1.5	vdds_ddr1	No	LVC MOS DDR	PUx/PDy	
AA16	ddr1_ba1	ddr1_ba1	0	O	PU	drive 1 (OFF)		1.35/1.5	vdds_ddr1	No	LVC MOS DDR	PUx/PDy	
AB16	ddr1_ba2	ddr1_ba2	0	O	PU	drive 1 (OFF)		1.35/1.5	vdds_ddr1	No	LVC MOS DDR	PUx/PDy	
AD16	ddr1_casn	ddr1_casn	0	O	PU	drive 1 (OFF)		1.35/1.5	vdds_ddr1	No	LVC MOS DDR	PUx/PDy	
AD21	ddr1_ck	ddr1_ck	0	O	PD	drive 0 (OFF)		1.35/1.5	vdds_ddr1	No	LVC MOS DDR	PUx/PDy	
AB18	ddr1_cke	ddr1_cke	0	O	PU	drive 1 (OFF)		1.35/1.5	vdds_ddr1	No	LVC MOS DDR	PUx/PDy	
AC19	ddr1_csn0	ddr1_csn0	0	O	PU	drive 1 (OFF)		1.35/1.5	vdds_ddr1	No	LVC MOS DDR	PUx/PDy	
AA23	ddr1_d0	ddr1_d0	0	IO	PD	PD		1.35/1.5	vdds_ddr1	No	LVC MOS DDR	PUx/PDy	
AC24	ddr1_d1	ddr1_d1	0	IO	PD	PD		1.35/1.5	vdds_ddr1	No	LVC MOS DDR	PUx/PDy	

Table 4-1. Pin Attributes<sup>(1)</sup> (continued)

BALL NUMBER [1]	BALL NAME [2]	SIGNAL NAME [3]	MUXMODE [4]	TYPE [5]	BALL RESET STATE [6]	BALL RESET REL. STATE [7]	BALL RESET REL. MUXMODE [8]	I/O VOLTAGE VALUE [9]	POWER [10]	HYS [11]	BUFFER TYPE [12]	PULL UP/DOWN TYPE [13]	DSIS [14]
AB24	ddr1_d2	ddr1_d2	0	IO	PD	PD		1.35/1.5	vdds_ddr1	No	LVC MOS DDR	PUx/PDy	
AD24	ddr1_d3	ddr1_d3	0	IO	PD	PD		1.35/1.5	vdds_ddr1	No	LVC MOS DDR	PUx/PDy	
AB23	ddr1_d4	ddr1_d4	0	IO	PD	PD		1.35/1.5	vdds_ddr1	No	LVC MOS DDR	PUx/PDy	
AC23	ddr1_d5	ddr1_d5	0	IO	PD	PD		1.35/1.5	vdds_ddr1	No	LVC MOS DDR	PUx/PDy	
AD23	ddr1_d6	ddr1_d6	0	IO	PD	PD		1.35/1.5	vdds_ddr1	No	LVC MOS DDR	PUx/PDy	
AE24	ddr1_d7	ddr1_d7	0	IO	PD	PD		1.35/1.5	vdds_ddr1	No	LVC MOS DDR	PUx/PDy	
AA24	ddr1_d8	ddr1_d8	0	IO	PD	PD		1.35/1.5	vdds_ddr1	No	LVC MOS DDR	PUx/PDy	
W25	ddr1_d9	ddr1_d9	0	IO	PD	PD		1.35/1.5	vdds_ddr1	No	LVC MOS DDR	PUx/PDy	
Y23	ddr1_d10	ddr1_d10	0	IO	PD	PD		1.35/1.5	vdds_ddr1	No	LVC MOS DDR	PUx/PDy	
AD25	ddr1_d11	ddr1_d11	0	IO	PD	PD		1.35/1.5	vdds_ddr1	No	LVC MOS DDR	PUx/PDy	
AC25	ddr1_d12	ddr1_d12	0	IO	PD	PD		1.35/1.5	vdds_ddr1	No	LVC MOS DDR	PUx/PDy	
AB25	ddr1_d13	ddr1_d13	0	IO	PD	PD		1.35/1.5	vdds_ddr1	No	LVC MOS DDR	PUx/PDy	
AA25	ddr1_d14	ddr1_d14	0	IO	PD	PD		1.35/1.5	vdds_ddr1	No	LVC MOS DDR	PUx/PDy	
W24	ddr1_d15	ddr1_d15	0	IO	PD	PD		1.35/1.5	vdds_ddr1	No	LVC MOS DDR	PUx/PDy	
W23	ddr1_d16	ddr1_d16	0	IO	PD	PD		1.35/1.5	vdds_ddr1	No	LVC MOS DDR	PUx/PDy	
U25	ddr1_d17	ddr1_d17	0	IO	PD	PD		1.35/1.5	vdds_ddr1	No	LVC MOS DDR	PUx/PDy	
U24	ddr1_d18	ddr1_d18	0	IO	PD	PD		1.35/1.5	vdds_ddr1	No	LVC MOS DDR	PUx/PDy	
W21	ddr1_d19	ddr1_d19	0	IO	PD	PD		1.35/1.5	vdds_ddr1	No	LVC MOS DDR	PUx/PDy	
T22	ddr1_d20	ddr1_d20	0	IO	PD	PD		1.35/1.5	vdds_ddr1	No	LVC MOS DDR	PUx/PDy	
U22	ddr1_d21	ddr1_d21	0	IO	PD	PD		1.35/1.5	vdds_ddr1	No	LVC MOS DDR	PUx/PDy	
U23	ddr1_d22	ddr1_d22	0	IO	PD	PD		1.35/1.5	vdds_ddr1	No	LVC MOS DDR	PUx/PDy	
T21	ddr1_d23	ddr1_d23	0	IO	PD	PD		1.35/1.5	vdds_ddr1	No	LVC MOS DDR	PUx/PDy	
T23	ddr1_d24	ddr1_d24	0	IO	PD	PD		1.35/1.5	vdds_ddr1	No	LVC MOS DDR	PUx/PDy	

Table 4-1. Pin Attributes<sup>(1)</sup> (continued)

BALL NUMBER [1]	BALL NAME [2]	SIGNAL NAME [3]	MUXMODE [4]	TYPE [5]	BALL RESET STATE [6]	BALL RESET REL. STATE [7]	BALL RESET REL. MUXMODE [8]	I/O VOLTAGE VALUE [9]	POWER [10]	HYS [11]	BUFFER TYPE [12]	PULL UP/DOWN TYPE [13]	DSIS [14]
T25	ddr1_d25	ddr1_d25	0	IO	PD	PD		1.35/1.5	vdds_ddr1	No	LVC MOS DDR	PUx/PDy	
T24	ddr1_d26	ddr1_d26	0	IO	PD	PD		1.35/1.5	vdds_ddr1	No	LVC MOS DDR	PUx/PDy	
P21	ddr1_d27	ddr1_d27	0	IO	PD	PD		1.35/1.5	vdds_ddr1	No	LVC MOS DDR	PUx/PDy	
N21	ddr1_d28	ddr1_d28	0	IO	PD	PD		1.35/1.5	vdds_ddr1	No	LVC MOS DDR	PUx/PDy	
P22	ddr1_d29	ddr1_d29	0	IO	PD	PD		1.35/1.5	vdds_ddr1	No	LVC MOS DDR	PUx/PDy	
P23	ddr1_d30	ddr1_d30	0	IO	PD	PD		1.35/1.5	vdds_ddr1	No	LVC MOS DDR	PUx/PDy	
P24	ddr1_d31	ddr1_d31	0	IO	PD	PD		1.35/1.5	vdds_ddr1	No	LVC MOS DDR	PUx/PDy	
AE23	ddr1_dqm0	ddr1_dqm0	0	O	PU	drive 1 (OFF)		1.35/1.5	vdds_ddr1	No	LVC MOS DDR	PUx/PDy	
W22	ddr1_dqm1	ddr1_dqm1	0	O	PU	drive 1 (OFF)		1.35/1.5	vdds_ddr1	No	LVC MOS DDR	PUx/PDy	
U21	ddr1_dqm2	ddr1_dqm2	0	O	PU	drive 1 (OFF)		1.35/1.5	vdds_ddr1	No	LVC MOS DDR	PUx/PDy	
P25	ddr1_dqm3	ddr1_dqm3	0	O	PU	drive 1 (OFF)		1.35/1.5	vdds_ddr1	No	LVC MOS DDR	PUx/PDy	
AD22	ddr1_dqs0	ddr1_dqs0	0	IO	PD	PD		1.35/1.5	vdds_ddr1		LVC MOS DDR	PUx/PDy	
Y24	ddr1_dqs1	ddr1_dqs1	0	IO	PD	PD		1.35/1.5	vdds_ddr1		LVC MOS DDR	PUx/PDy	
V24	ddr1_dqs2	ddr1_dqs2	0	IO	PD	PD		1.35/1.5	vdds_ddr1		LVC MOS DDR	PUx/PDy	
R24	ddr1_dqs3	ddr1_dqs3	0	IO	PD	PD		1.35/1.5	vdds_ddr1		LVC MOS DDR	PUx/PDy	
AE22	ddr1_dqsn0	ddr1_dqsn0	0	IO	PU	PU		1.35/1.5	vdds_ddr1		LVC MOS DDR	PUx/PDy	
Y25	ddr1_dqsn1	ddr1_dqsn1	0	IO	PU	PU		1.35/1.5	vdds_ddr1		LVC MOS DDR	PUx/PDy	
V25	ddr1_dqsn2	ddr1_dqsn2	0	IO	PU	PU		1.35/1.5	vdds_ddr1		LVC MOS DDR	PUx/PDy	
R25	ddr1_dqsn3	ddr1_dqsn3	0	IO	PU	PU		1.35/1.5	vdds_ddr1		LVC MOS DDR	PUx/PDy	
AE21	ddr1_nck	ddr1_nck	0	O	PU	drive 1 (OFF)		1.35/1.5	vdds_ddr1	No	LVC MOS DDR	PUx/PDy	
AD18	ddr1_odt0	ddr1_odt0	0	O	PD	drive 0 (OFF)		1.35/1.5	vdds_ddr1	No	LVC MOS DDR	PUx/PDy	
AD17	ddr1_rasn	ddr1_rasn	0	O	PU	drive 1 (OFF)		1.35/1.5	vdds_ddr1	No	LVC MOS DDR	PUx/PDy	
AE17	ddr1_rst	ddr1_rst	0	O	PD	drive 0 (OFF)		1.35/1.5	vdds_ddr1	No	LVC MOS DDR	PUx/PDy	

Table 4-1. Pin Attributes<sup>(1)</sup> (continued)

BALL NUMBER [1]	BALL NAME [2]	SIGNAL NAME [3]	MUXMODE [4]	TYPE [5]	BALL RESET STATE [6]	BALL RESET REL. STATE [7]	BALL RESET REL. MUXMODE [8]	I/O VOLTAGE VALUE [9]	POWER [10]	HYS [11]	BUFFER TYPE [12]	PULL UP/DOWN TYPE [13]	DSIS [14]
Y20	ddr1_vref0	ddr1_vref0	0	PWR	OFF	drive 1 (OFF)		1.35/1.5	vdds_ddr1	No	LVCOS DDR		
AE18	ddr1_wen	ddr1_wen	0	O	PU	drive 1 (OFF)		1.35/1.5	vdds_ddr1	No	LVCOS DDR	PUx/PDy	
C21	emu0	emu0	0	IO	PU	PU	0	1.8/3.3	vddshv3	Yes	Dual Voltage LVCOS	PU/PD	
		gpio8_30	14	IO									
C22	emu1	emu1	0	IO	PU	PU	0	1.8/3.3	vddshv3	Yes	Dual Voltage LVCOS	PU/PD	
		gpio8_31	14	IO									
E14	emu2	emu2	2	O	PD	PD	15	1.8/3.3	vddshv3	Yes	Dual Voltage LVCOS	PU/PD	
F14	emu3	emu3	2	O	PD	PD	15	1.8/3.3	vddshv3	Yes	Dual Voltage LVCOS	PU/PD	
F13	emu4	emu4	2	O	PD	PD	15	1.8/3.3	vddshv3	Yes	Dual Voltage LVCOS	PU/PD	
Y5	gpio6_10	gpio6_10	0	IO	PU	PU	15	1.8/3.3	vddshv7	Yes	Dual Voltage LVCOS	PU/PD	
		mdio_mclk	1	O									1
		i2c3_sda	2	IO									1
		usb3_ulpi_d7	3	IO									0
		vin2b_hsync1	4	I									
		vin1a_clk0	9	I									0
		ehrpwm2A	10	O									
		gpio6_10	14	IO									
		Driver off	15	I									
Y6	gpio6_11	gpio6_11	0	IO	PU	PU	15	1.8/3.3	vddshv7	Yes	Dual Voltage LVCOS	PU/PD	
		mdio_d	1	IO									1
		i2c3_scl	2	IO									1
		usb3_ulpi_d6	3	IO									0
		vin2b_vsync1	4	I									
		vin1a_de0	9	I									0
		ehrpwm2B	10	O									
		gpio6_11	14	IO									
		Driver off	15	I									
H21	gpio6_14	gpio6_14	0	IO	PU	PU	15	1.8/3.3	vddshv3	Yes	Dual Voltage LVCOS	PU/PD	
		mcasp1_axr8	1	IO									0
		dcan2_tx	2	IO									1
		uart10_rxd	3	I									1
		i2c3_sda	9	IO									1
		timer1	10	IO									
		gpio6_14	14	IO									
		Driver off	15	I									



Table 4-1. Pin Attributes<sup>(1)</sup> (continued)

BALL NUMBER [1]	BALL NAME [2]	SIGNAL NAME [3]	MUXMODE [4]	TYPE [5]	BALL RESET STATE [6]	BALL RESET REL. STATE [7]	BALL RESET REL. MUXMODE [8]	I/O VOLTAGE VALUE [9]	POWER [10]	HYS [11]	BUFFER TYPE [12]	PULL UP/DOWN TYPE [13]	DSIS [14]
K22	gpio6_15	gpio6_15	0	IO	PU	PU	15	1.8/3.3	vddshv3	Yes	Dual Voltage LVCMOS	PU/PD	
		mcasp1_axr9	1	IO									0
		dcan2_rx	2	IO									1
		uart10_txd	3	O									
		i2c3_scl	9	IO									1
		timer2	10	IO									
		gpio6_15	14	IO									
		Driver off	15	I									
K23	gpio6_16	gpio6_16	0	IO	PU	PU	15	1.8/3.3	vddshv3	Yes	Dual Voltage LVCMOS	PU/PD	
		mcasp1_axr10	1	IO									0
		clkout1	9	O									
		timer3	10	IO									
		gpio6_16	14	IO									
		Driver off	15	I									
M1	gpmc_a0	gpmc_a0	0	O	PD	PD	15	1.8/3.3	vddshv10	Yes	Dual Voltage LVCMOS	PU/PD	
		vin1a_d16	2	I									0
		vout3_d16	3	O									
		vin1b_d0	6	I									0
		i2c4_scl	7	IO									1
		uart5_rxd	8	I									1
		gpio7_3 gpmc_a26 gpmc_a16	14	IO									
		Driver off	15	I									
M2	gpmc_a1	gpmc_a1	0	O	PD	PD	15	1.8/3.3	vddshv10	Yes	Dual Voltage LVCMOS	PU/PD	
		vin1a_d17	2	I									0
		vout3_d17	3	O									
		vin1b_d1	6	I									0
		i2c4_sda	7	IO									1
		uart5_bxd	8	O									
		gpio7_4	14	IO									
		Driver off	15	I									

Table 4-1. Pin Attributes<sup>(1)</sup> (continued)

BALL NUMBER [1]	BALL NAME [2]	SIGNAL NAME [3]	MUXMODE [4]	TYPE [5]	BALL RESET STATE [6]	BALL RESET REL. STATE [7]	BALL RESET REL. MUXMODE [8]	I/O VOLTAGE VALUE [9]	POWER [10]	HYS [11]	BUFFER TYPE [12]	PULL UP/DOWN TYPE [13]	DSIS [14]
L2	gpmc_a2	gpmc_a2	0	O	PD	PD	15	1.8/3.3	vddshv10	Yes	Dual Voltage LVCMOS	PU/PD	
		vin1a_d18	2	I									0
		vout3_d18	3	O									
		vin1b_d2	6	I									0
		uart7_rxd	7	I									1
		uart5_ctsn	8	I									1
		gpio7_5	14	IO									
Driver off	15	I											
L1	gpmc_a3	gpmc_a3	0	O	PD	PD	15	1.8/3.3	vddshv10	Yes	Dual Voltage LVCMOS	PU/PD	
		qspi1_cs2	1	O									1
		vin1a_d19	2	I									0
		vout3_d19	3	O									
		vin1b_d3	6	I									0
		uart7_txd	7	O									
		uart5_rtsn	8	O									
gpio7_6	14	IO											
Driver off	15	I											
K3	gpmc_a4	gpmc_a4	0	O	PD	PD	15	1.8/3.3	vddshv10	Yes	Dual Voltage LVCMOS	PU/PD	
		qspi1_cs3	1	O									1
		vin1a_d20	2	I									0
		vout3_d20	3	O									
		vin1b_d4	6	I									0
		i2c5_scl	7	IO									1
		uart6_rxd	8	I									1
gpio1_26	14	IO											
Driver off	15	I											
K2	gpmc_a5	gpmc_a5	0	O	PD	PD	15	1.8/3.3	vddshv10	Yes	Dual Voltage LVCMOS	PU/PD	
		vin1a_d21	2	I									0
		vout3_d21	3	O									
		vin1b_d5	6	I									0
		i2c5_sda	7	IO									1
		uart6_txd	8	O									
		gpio1_27	14	IO									
Driver off	15	I											

Table 4-1. Pin Attributes<sup>(1)</sup> (continued)

BALL NUMBER [1]	BALL NAME [2]	SIGNAL NAME [3]	MUXMODE [4]	TYPE [5]	BALL RESET STATE [6]	BALL RESET REL. STATE [7]	BALL RESET REL. MUXMODE [8]	I/O VOLTAGE VALUE [9]	POWER [10]	HYS [11]	BUFFER TYPE [12]	PULL UP/DOWN TYPE [13]	DSIS [14]
J1	gpmc_a6	gpmc_a6	0	O	PD	PD	15	1.8/3.3	vddshv10	Yes	Dual Voltage LVCMOS	PU/PD	
		vin1a_d22	2	I									0
		vout3_d22	3	O									
		vin1b_d6	6	I									0
		uart8_rxd	7	I									1
		uart6_ctsn	8	I									1
		gpio1_28	14	IO									
		Driver off	15	I									
K1	gpmc_a7	gpmc_a7	0	O	PD	PD	15	1.8/3.3	vddshv10	Yes	Dual Voltage LVCMOS	PU/PD	
		vin1a_d23	2	I									0
		vout3_d23	3	O									
		vin1b_d7	6	I									0
		uart8_txd	7	O									
		uart6_rtsn	8	O									
		gpio1_29	14	IO									
		Driver off	15	I									
K4	gpmc_a8	gpmc_a8	0	O	PD	PD	15	1.8/3.3	vddshv10	Yes	Dual Voltage LVCMOS	PU/PD	
		vin1a_hsync0	2	I									0
		vout3_hsync	3	O									
		vin1b_hsync1	6	I									0
		timer12	7	IO									
		spi4_sclk	8	IO									0
		gpio1_30	14	IO									
		Driver off	15	I									
H1	gpmc_a9	gpmc_a9	0	O	PD	PD	15	1.8/3.3	vddshv10	Yes	Dual Voltage LVCMOS	PU/PD	
		vin1a_vsync0	2	I									0
		vout3_vsync	3	O									
		vin1b_vsync1	6	I									0
		timer11	7	IO									
		spi4_d1	8	IO									0
		gpio1_31	14	IO									
		Driver off	15	I									

Table 4-1. Pin Attributes<sup>(1)</sup> (continued)

BALL NUMBER [1]	BALL NAME [2]	SIGNAL NAME [3]	MUXMODE [4]	TYPE [5]	BALL RESET STATE [6]	BALL RESET REL. STATE [7]	BALL RESET REL. MUXMODE [8]	I/O VOLTAGE VALUE [9]	POWER [10]	HYS [11]	BUFFER TYPE [12]	PULL UP/DOWN TYPE [13]	DSIS [14]
J2	gpmc_a10	gpmc_a10	0	O	PD	PD	15	1.8/3.3	vddshv10	Yes	Dual Voltage LVCMOS	PU/PD	
		vin1a_de0	2	I									0
		vout3_de	3	O									
		vin1b_clk1	6	I									0
		timer10	7	IO									
		spi4_d0	8	IO									0
		gpio2_0	14	IO									
Driver off	15	I											
L3	gpmc_a11	gpmc_a11	0	O	PD	PD	15	1.8/3.3	vddshv10	Yes	Dual Voltage LVCMOS	PU/PD	
		vin1a_fld0	2	I									0
		vout3_fld	3	O									
		vin1b_de1	6	I									0
		timer9	7	IO									
		spi4_cs0	8	IO									1
		gpio2_1	14	IO									
Driver off	15	I											
G1	gpmc_a12	gpmc_a12	0	O	PD	PD	15	1.8/3.3	vddshv10	Yes	Dual Voltage LVCMOS	PU/PD	
		gpmc_a0	5	O									
		vin1b_fld1	6	I									0
		timer8	7	IO									
		spi4_cs1	8	IO									1
		dma_evt1	9	I									0
		gpio2_2	14	IO									
Driver off	15	I											
H3	gpmc_a13	gpmc_a13	0	O	PD	PD	15	1.8/3.3	vddshv10	Yes	Dual Voltage LVCMOS	PU/PD	
		qspi1_rtclk	1	I									0
		timer7	7	IO									
		spi4_cs2	8	IO									1
		dma_evt2	9	I									0
		gpio2_3	14	IO									
Driver off	15	I											
H4	gpmc_a14	gpmc_a14	0	O	PD	PD	15	1.8/3.3	vddshv10	Yes	Dual Voltage LVCMOS	PU/PD	
		qspi1_d3	1	IO									0
		timer6	7	IO									
		spi4_cs3	8	IO									1
		gpio2_4	14	IO									
Driver off	15	I											

Table 4-1. Pin Attributes<sup>(1)</sup> (continued)

BALL NUMBER [1]	BALL NAME [2]	SIGNAL NAME [3]	MUXMODE [4]	TYPE [5]	BALL RESET STATE [6]	BALL RESET REL. STATE [7]	BALL RESET REL. MUXMODE [8]	I/O VOLTAGE VALUE [9]	POWER [10]	HYS [11]	BUFFER TYPE [12]	PULL UP/DOWN TYPE [13]	DSIS [14]
K6	gpmc_a15	gpmc_a15	0	O	PD	PD	15	1.8/3.3	vddshv10	Yes	Dual Voltage LVCMOS	PU/PD	
		qspi1_d2	1	IO									0
		timer5	7	IO									
		gpio2_5	14	IO									
		Driver off	15	I									
K5	gpmc_a16	gpmc_a16	0	O	PD	PD	15	1.8/3.3	vddshv10	Yes	Dual Voltage LVCMOS	PU/PD	
		qspi1_d0	1	IO									0
		gpio2_6	14	IO									
		Driver off	15	I									
G2	gpmc_a17	gpmc_a17	0	O	PD	PD	15	1.8/3.3	vddshv10	Yes	Dual Voltage LVCMOS	PU/PD	
		qspi1_d1	1	IO									0
		gpio2_7	14	IO									
		Driver off	15	I									
F2	gpmc_a18	gpmc_a18	0	O	PD	PD	15	1.8/3.3	vddshv10	Yes	Dual Voltage LVCMOS	PU/PD	
		qspi1_sclk	1	IO									
		gpio2_8	14	IO									
		Driver off	15	I									
A4 <sup>(9)</sup>	gpmc_a19	gpmc_a19	0	O	PD	PD	15	1.8/3.3	vddshv11	Yes	Dual Voltage LVCMOS	PU/PD	
		mmc2_dat4	1	IO									1
		gpmc_a13	2	O									
		vin2b_d0	6	I									0
		gpio2_9	14	IO									
E7 <sup>(9)</sup>	gpmc_a20	gpmc_a20	0	O	PD	PD	15	1.8/3.3	vddshv11	Yes	Dual Voltage LVCMOS	PU/PD	
		mmc2_dat5	1	IO									1
		gpmc_a14	2	O									
		vin2b_d1	6	I									0
		gpio2_10	14	IO									
D6 <sup>(9)</sup>	gpmc_a21	gpmc_a21	0	O	PD	PD	15	1.8/3.3	vddshv11	Yes	Dual Voltage LVCMOS	PU/PD	
		mmc2_dat6	1	IO									1
		gpmc_a15	2	O									
		vin2b_d2	6	I									0
		gpio2_11	14	IO									
		Driver off	15	I									

Table 4-1. Pin Attributes<sup>(1)</sup> (continued)

BALL NUMBER [1]	BALL NAME [2]	SIGNAL NAME [3]	MUXMODE [4]	TYPE [5]	BALL RESET STATE [6]	BALL RESET REL. STATE [7]	BALL RESET REL. MUXMODE [8]	I/O VOLTAGE VALUE [9]	POWER [10]	HYS [11]	BUFFER TYPE [12]	PULL UP/DOWN TYPE [13]	DSIS [14]
C5 <sup>(9)</sup>	gpmc_a22	gpmc_a22	0	O	PD	PD	15	1.8/3.3	vddshv11	Yes	Dual Voltage LVCMOS	PU/PD	
		mmc2_dat7	1	IO									1
		gpmc_a16	2	O									
		vin2b_d3	6	I									0
		gpio2_12	14	IO									
		Driver off	15	I									
B5	gpmc_a23	gpmc_a23	0	O	PD	PD	15	1.8/3.3	vddshv11	Yes	Dual Voltage LVCMOS	PU/PD	
		mmc2_clk	1	IO									1
		gpmc_a17	2	O									
		vin2b_d4	6	I									0
		gpio2_13	14	IO									
		Driver off	15	I									
D7 <sup>(9)</sup>	gpmc_a24	gpmc_a24	0	O	PD	PD	15	1.8/3.3	vddshv11	Yes	Dual Voltage LVCMOS	PU/PD	
		mmc2_dat0	1	IO									1
		gpmc_a18	2	O									
		vin2b_d5	6	I									0
		gpio2_14	14	IO									
		Driver off	15	I									
C6 <sup>(9)</sup>	gpmc_a25	gpmc_a25	0	O	PD	PD	15	1.8/3.3	vddshv11	Yes	Dual Voltage LVCMOS	PU/PD	
		mmc2_dat1	1	IO									1
		gpmc_a19	2	O									
		vin2b_d6	6	I									0
		gpio2_15	14	IO									
		Driver off	15	I									
A5 <sup>(9)</sup>	gpmc_a26	gpmc_a26	0	O	PD	PD	15	1.8/3.3	vddshv11	Yes	Dual Voltage LVCMOS	PU/PD	
		mmc2_dat2	1	IO									1
		gpmc_a20	2	O									
		vin2b_d7	6	I									0
		gpio2_16	14	IO									
		Driver off	15	I									
B6 <sup>(9)</sup>	gpmc_a27	gpmc_a27	0	O	PD	PD	15	1.8/3.3	vddshv11	Yes	Dual Voltage LVCMOS	PU/PD	
		mmc2_dat3	1	IO									1
		gpmc_a21	2	O									
		vin2b_hsync1	6	I									
		gpio2_17	14	IO									
		Driver off	15	I									

Table 4-1. Pin Attributes<sup>(1)</sup> (continued)

BALL NUMBER [1]	BALL NAME [2]	SIGNAL NAME [3]	MUXMODE [4]	TYPE [5]	BALL RESET STATE [6]	BALL RESET REL. STATE [7]	BALL RESET REL. MUXMODE [8]	I/O VOLTAGE VALUE [9]	POWER [10]	HYS [11]	BUFFER TYPE [12]	PULL UP/DOWN TYPE [13]	DSIS [14]
F1	gpmc_ad0	gpmc_ad0	0	IO	OFF	OFF	15	1.8/3.3	vddshv10	Yes	Dual Voltage LVCMOS	PU/PD	0
		vin1a_d0	2	I									0
		vout3_d0	3	O									
		gpio1_6	14	IO									
		sysboot0	15	I									
E2	gpmc_ad1	gpmc_ad1	0	IO	OFF	OFF	15	1.8/3.3	vddshv10	Yes	Dual Voltage LVCMOS	PU/PD	0
		vin1a_d1	2	I									0
		vout3_d1	3	O									
		gpio1_7	14	IO									
		sysboot1	15	I									
E1	gpmc_ad2	gpmc_ad2	0	IO	OFF	OFF	15	1.8/3.3	vddshv10	Yes	Dual Voltage LVCMOS	PU/PD	0
		vin1a_d2	2	I									0
		vout3_d2	3	O									
		gpio1_8	14	IO									
		sysboot2	15	I									
C1	gpmc_ad3	gpmc_ad3	0	IO	OFF	OFF	15	1.8/3.3	vddshv10	Yes	Dual Voltage LVCMOS	PU/PD	0
		vin1a_d3	2	I									0
		vout3_d3	3	O									
		gpio1_9	14	IO									
		sysboot3	15	I									
D1	gpmc_ad4	gpmc_ad4	0	IO	OFF	OFF	15	1.8/3.3	vddshv10	Yes	Dual Voltage LVCMOS	PU/PD	0
		vin1a_d4	2	I									0
		vout3_d4	3	O									
		gpio1_10	14	IO									
		sysboot4	15	I									
D2	gpmc_ad5	gpmc_ad5	0	IO	OFF	OFF	15	1.8/3.3	vddshv10	Yes	Dual Voltage LVCMOS	PU/PD	0
		vin1a_d5	2	I									0
		vout3_d5	3	O									
		gpio1_11	14	IO									
		sysboot5	15	I									
B1	gpmc_ad6	gpmc_ad6	0	IO	OFF	OFF	15	1.8/3.3	vddshv10	Yes	Dual Voltage LVCMOS	PU/PD	0
		vin1a_d6	2	I									0
		vout3_d6	3	O									
		gpio1_12	14	IO									
		sysboot6	15	I									

Table 4-1. Pin Attributes<sup>(1)</sup> (continued)

BALL NUMBER [1]	BALL NAME [2]	SIGNAL NAME [3]	MUXMODE [4]	TYPE [5]	BALL RESET STATE [6]	BALL RESET REL. STATE [7]	BALL RESET REL. MUXMODE [8]	I/O VOLTAGE VALUE [9]	POWER [10]	HYS [11]	BUFFER TYPE [12]	PULL UP/DOWN TYPE [13]	DSIS [14]
B2	gpmc_ad7	gpmc_ad7	0	IO	OFF	OFF	15	1.8/3.3	vddshv10	Yes	Dual Voltage LVCMOS	PU/PD	0
		vin1a_d7	2	I									0
		vout3_d7	3	O									
		gpio1_13	14	IO									
		sysboot7	15	I									
C2	gpmc_ad8	gpmc_ad8	0	IO	OFF	OFF	15	1.8/3.3	vddshv10	Yes	Dual Voltage LVCMOS	PU/PD	0
		vin1a_d8	2	I									0
		vout3_d8	3	O									
		gpio7_18	14	IO									
		sysboot8	15	I									
D3	gpmc_ad9	gpmc_ad9	0	IO	OFF	OFF	15	1.8/3.3	vddshv10	Yes	Dual Voltage LVCMOS	PU/PD	0
		vin1a_d9	2	I									0
		vout3_d9	3	O									
		gpio7_19	14	IO									
		sysboot9	15	I									
A2	gpmc_ad10	gpmc_ad10	0	IO	OFF	OFF	15	1.8/3.3	vddshv10	Yes	Dual Voltage LVCMOS	PU/PD	0
		vin1a_d10	2	I									0
		vout3_d10	3	O									
		gpio7_28	14	IO									
		sysboot10	15	I									
B3	gpmc_ad11	gpmc_ad11	0	IO	OFF	OFF	15	1.8/3.3	vddshv10	Yes	Dual Voltage LVCMOS	PU/PD	0
		vin1a_d11	2	I									0
		vout3_d11	3	O									
		gpio7_29	14	IO									
		sysboot11	15	I									
C3	gpmc_ad12	gpmc_ad12	0	IO	OFF	OFF	15	1.8/3.3	vddshv10	Yes	Dual Voltage LVCMOS	PU/PD	0
		vin1a_d12	2	I									0
		vout3_d12	3	O									
		gpio1_18	14	IO									
		sysboot12	15	I									
C4	gpmc_ad13	gpmc_ad13	0	IO	OFF	OFF	15	1.8/3.3	vddshv10	Yes	Dual Voltage LVCMOS	PU/PD	0
		vin1a_d13	2	I									0
		vout3_d13	3	O									
		gpio1_19	14	IO									
		sysboot13	15	I									



Table 4-1. Pin Attributes<sup>(1)</sup> (continued)

BALL NUMBER [1]	BALL NAME [2]	SIGNAL NAME [3]	MUXMODE [4]	TYPE [5]	BALL RESET STATE [6]	BALL RESET REL. STATE [7]	BALL RESET REL. MUXMODE [8]	I/O VOLTAGE VALUE [9]	POWER [10]	HYS [11]	BUFFER TYPE [12]	PULL UP/DOWN TYPE [13]	DSIS [14]
A3	gpmc_ad14	gpmc_ad14	0	IO	OFF	OFF	15	1.8/3.3	vddshv10	Yes	Dual Voltage LVCMOS	PU/PD	0
		vin1a_d14	2	I									0
		vout3_d14	3	O									
		gpio1_20	14	IO									
		sysboot14	15	I									
B4	gpmc_ad15	gpmc_ad15	0	IO	OFF	OFF	15	1.8/3.3	vddshv10	Yes	Dual Voltage LVCMOS	PU/PD	0
		vin1a_d15	2	I									0
		vout3_d15	3	O									
		gpio1_21	14	IO									
		sysboot15	15	I									
H5	gpmc_advn_ale	gpmc_advn_ale	0	O	PU	PU	15	1.8/3.3	vddshv10	Yes	Dual Voltage LVCMOS	PU/PD	
		gpmc_cs6	1	O									
		clkout2	2	O									
		gpmc_wait1	3	I									1
		gpmc_a2	5	O									
		gpmc_a23	6	O									
		timer3	7	IO									
		i2c3_sda	8	IO									1
		dma_evt2	9	I									0
		gpio2_23	14	IO									
		gpmc_a19											
		Driver off	15	I									
H2	gpmc_ben0	gpmc_ben0	0	O	PU	PU	15	1.8/3.3	vddshv10	Yes	Dual Voltage LVCMOS	PU/PD	
		gpmc_cs4	1	O									
		vin2b_de1	6	I									
		timer2	7	IO									
		dma_evt3	9	I									0
		gpio2_26	14	IO									
		gpmc_a21											
Driver off	15	I											

Table 4-1. Pin Attributes<sup>(1)</sup> (continued)

BALL NUMBER [1]	BALL NAME [2]	SIGNAL NAME [3]	MUXMODE [4]	TYPE [5]	BALL RESET STATE [6]	BALL RESET REL. STATE [7]	BALL RESET REL. MUXMODE [8]	I/O VOLTAGE VALUE [9]	POWER [10]	HYS [11]	BUFFER TYPE [12]	PULL UP/DOWN TYPE [13]	DSIS [14]
H6	gpmc_ben1	gpmc_ben1	0	O	PU	PU	15	1.8/3.3	vddshv10	Yes	Dual Voltage LVCMOS	PU/PD	
		gpmc_cs5	1	O									
		vin2b_clk1	4	I									
		gpmc_a3	5	O									
		vin2b_fld1	6	I									
		timer1	7	IO									
		dma_evt4	9	I									
		gpio2_27 gpmc_a22	14	IO									
		Driver off	15	I									
L4	gpmc_clk	gpmc_clk	0	IO	PU	PU	15	1.8/3.3	vddshv10	Yes	Dual Voltage LVCMOS	PU/PD	0
		gpmc_cs7	1	O									
		clkout1	2	O									
		gpmc_wait1	3	I									
		vin2b_clk1	6	I									
		timer4	7	IO									
		i2c3_scl	8	IO									
		dma_evt1	9	I									
		gpio2_22 gpmc_a20	14	IO									
		Driver off	15	I									
		F3	gpmc_cs0	gpmc_cs0									0
gpio2_19	14			IO									
Driver off	15			I									
A6	gpmc_cs1	gpmc_cs1	0	O	PU	PU	15	1.8/3.3	vddshv11	Yes	Dual Voltage LVCMOS	PU/PD	1
		mmc2_cmd	1	IO									
		gpmc_a22	2	O									
		vin2b_vsync1	6	I									
		gpio2_18 Driver off	14 15	IO I									
G4	gpmc_cs2	gpmc_cs2	0	O	PU	PU	15	1.8/3.3	vddshv10	Yes	Dual Voltage LVCMOS	PU/PD	
		qspi1_cs0	1	IO									
		gpio2_20 gpmc_a23 gpmc_a13	14	IO									
		Driver off	15	I									

Table 4-1. Pin Attributes<sup>(1)</sup> (continued)

BALL NUMBER [1]	BALL NAME [2]	SIGNAL NAME [3]	MUXMODE [4]	TYPE [5]	BALL RESET STATE [6]	BALL RESET REL. STATE [7]	BALL RESET REL. MUXMODE [8]	I/O VOLTAGE VALUE [9]	POWER [10]	HYS [11]	BUFFER TYPE [12]	PULL UP/DOWN TYPE [13]	DSIS [14]
G3	gpmc_cs3	gpmc_cs3	0	O	PU	PU	15	1.8/3.3	vddshv10	Yes	Dual Voltage LVCMOS	PU/PD	
		qspi1_cs1	1	O									1
		vin1a_clk0	2	I									0
		vout3_clk	3	O									
		gpmc_a1	5	O									
		gpio2_21 gpmc_a24 gpmc_a14	14	IO									
		Driver off	15	I									
G5	gpmc_oen_ren	gpmc_oen_ren	0	O	PU	PU	15	1.8/3.3	vddshv10	Yes	Dual Voltage LVCMOS	PU/PD	
		gpio2_24	14	IO									
		Driver off	15	I									
F6	gpmc_wait0	gpmc_wait0	0	I	PU	PU	15	1.8/3.3	vddshv10	Yes	Dual Voltage LVCMOS	PU/PD	1
		gpio2_28 gpmc_a25 gpmc_a15	14	IO									
		Driver off	15	I									
G6	gpmc_wen	gpmc_wen	0	O	PU	PU	15	1.8/3.3	vddshv10	Yes	Dual Voltage LVCMOS	PU/PD	
		gpio2_25	14	IO									
		Driver off	15	I									
AE9	hdmi1_clockx	hdmi1_clockx	0	O				1.8	vdda_hdmi		HDMIPHY	Pdy	
AD10	hdmi1_clocky	hdmi1_clocky	0	O				1.8	vdda_hdmi		HDMIPHY	Pdy	
AE11	hdmi1_data0x	hdmi1_data0x	0	O				1.8	vdda_hdmi		HDMIPHY	Pdy	
AD12	hdmi1_data0y	hdmi1_data0y	0	O				1.8	vdda_hdmi		HDMIPHY	Pdy	
AE12	hdmi1_data1x	hdmi1_data1x	0	O				1.8	vdda_hdmi		HDMIPHY	Pdy	
AD13	hdmi1_data1y	hdmi1_data1y	0	O				1.8	vdda_hdmi		HDMIPHY	Pdy	
AE14	hdmi1_data2x	hdmi1_data2x	0	O				1.8	vdda_hdmi		HDMIPHY	Pdy	
AD15	hdmi1_data2y	hdmi1_data2y	0	O				1.8	vdda_hdmi		HDMIPHY	Pdy	
G22	i2c1_scl	i2c1_scl	0	IO				1.8/3.3	vddshv3	Yes	Dual Voltage LVCMOS I2C	PU/PD	
		Driver off	15	I									
G23	i2c1_sda	i2c1_sda	0	IO				1.8/3.3	vddshv3	Yes	Dual Voltage LVCMOS I2C	PU/PD	
		Driver off	15	I									
G21	i2c2_scl	i2c2_scl	0	IO			15	1.8/3.3	vddshv3	Yes	Dual Voltage LVCMOS I2C	PU/PD	1
		hdmi1_ddc_sda	1	IO									
		Driver off	15	I									
F23	i2c2_sda	i2c2_sda	0	IO			15	1.8/3.3	vddshv3	Yes	Dual Voltage LVCMOS I2C	PU/PD	1
		hdmi1_ddc_scl	1	IO									
		Driver off	15	I									
AB9	ljcb_clkn	ljcb_clkn	0	IO				1.8	vdda_pcie		LJCB		

Table 4-1. Pin Attributes<sup>(1)</sup> (continued)

BALL NUMBER [1]	BALL NAME [2]	SIGNAL NAME [3]	MUXMODE [4]	TYPE [5]	BALL RESET STATE [6]	BALL RESET REL. STATE [7]	BALL RESET REL. MUXMODE [8]	I/O VOLTAGE VALUE [9]	POWER [10]	HYS [11]	BUFFER TYPE [12]	PULL UP/DOWN TYPE [13]	DSIS [14]
AC8	ljcb_clkp	ljcb_clkp	0	IO				1.8	vdda_pcie		LJCB		
D16	mcasep1_aclkr	mcasep1_aclkr	0	IO	PD	PD	15	1.8/3.3	vddshv3	Yes	Dual Voltage LVCMOS	PU/PD	0
		mcasep7_axr2	1	IO									0
		i2c4_sda	10	IO									1
		gpio5_0	14	IO									
		Driver off	15	I									
C16	mcasep1_aclkx	mcasep1_aclkx	0	IO	PD	PD	15	1.8/3.3	vddshv3	Yes	Dual Voltage LVCMOS	PU/PD	0
		vin1a_fid0	7	I									0
		i2c3_sda	10	IO									1
		gpio7_31	14	IO									
		Driver off	15	I									
D14	mcasep1_axr0	mcasep1_axr0	0	IO	PD	PD	15	1.8/3.3	vddshv3	Yes	Dual Voltage LVCMOS	PU/PD	0
		uart6_rxd	3	I									1
		vin1a_vsync0	7	I									0
		i2c5_sda	10	IO									1
		gpio5_2	14	IO									
		Driver off	15	I									
B14	mcasep1_axr1	mcasep1_axr1	0	IO	PD	PD	15	1.8/3.3	vddshv3	Yes	Dual Voltage LVCMOS	PU/PD	0
		uart6_txd	3	O									
		vin1a_hsync0	7	I									0
		i2c5_scl	10	IO									1
		gpio5_3	14	IO									
		Driver off	15	I									
C14	mcasep1_axr2	mcasep1_axr2	0	IO	PD	PD	15	1.8/3.3	vddshv3	Yes	Dual Voltage LVCMOS	PU/PD	0
		mcasep6_axr2	1	IO									0
		uart6_ctsn	3	I									1
		gpio5_4	14	IO									
		Driver off	15	I									
B15	mcasep1_axr3	mcasep1_axr3	0	IO	PD	PD	15	1.8/3.3	vddshv3	Yes	Dual Voltage LVCMOS	PU/PD	0
		mcasep6_axr3	1	IO									0
		uart6_rtsn	3	O									
		gpio5_5	14	IO									
		Driver off	15	I									
A15	mcasep1_axr4	mcasep1_axr4	0	IO	PD	PD	15	1.8/3.3	vddshv3	Yes	Dual Voltage LVCMOS	PU/PD	0
		mcasep4_axr2	1	IO									0
		gpio5_6	14	IO									
		Driver off	15	I									

Table 4-1. Pin Attributes<sup>(1)</sup> (continued)

BALL NUMBER [1]	BALL NAME [2]	SIGNAL NAME [3]	MUXMODE [4]	TYPE [5]	BALL RESET STATE [6]	BALL RESET REL. STATE [7]	BALL RESET REL. MUXMODE [8]	I/O VOLTAGE VALUE [9]	POWER [10]	HYS [11]	BUFFER TYPE [12]	PULL UP/DOWN TYPE [13]	DSIS [14]
A14	mcasep1_axr5	mcasep1_axr5	0	IO	PD	PD	15	1.8/3.3	vddshv3	Yes	Dual Voltage LVCMOS	PU/PD	0
		mcasep4_axr3	1	IO									0
		gpio5_7	14	IO									
		Driver off	15	I									
A17	mcasep1_axr6	mcasep1_axr6	0	IO	PD	PD	15	1.8/3.3	vddshv3	Yes	Dual Voltage LVCMOS	PU/PD	0
		mcasep5_axr2	1	IO									0
		gpio5_8	14	IO									
		Driver off	15	I									
A16	mcasep1_axr7	mcasep1_axr7	0	IO	PD	PD	15	1.8/3.3	vddshv3	Yes	Dual Voltage LVCMOS	PU/PD	0
		mcasep5_axr3	1	IO									0
		timer4	10	IO									
		gpio5_9	14	IO									
		Driver off	15	I									
A18	mcasep1_axr8	mcasep1_axr8	0	IO	PD	PD	15	1.8/3.3	vddshv3	Yes	Dual Voltage LVCMOS	PU/PD	0
		mcasep6_axr0	1	IO									0
		spi3_sclk	3	IO									0
		vin1a_d15	7	I									0
		timer5	10	IO									
		gpio5_10	14	IO									
		Driver off	15	I									
B17	mcasep1_axr9	mcasep1_axr9	0	IO	PD	PD	15	1.8/3.3	vddshv3	Yes	Dual Voltage LVCMOS	PU/PD	0
		mcasep6_axr1	1	IO									0
		spi3_d1	3	IO									0
		vin1a_d14	7	I									0
		timer6	10	IO									
		gpio5_11	14	IO									
		Driver off	15	I									
B16	mcasep1_axr10	mcasep1_axr10	0	IO	PD	PD	15	1.8/3.3	vddshv3	Yes	Dual Voltage LVCMOS	PU/PD	0
		mcasep6_aclkx	1	IO									0
		mcasep6_aclkr	2	IO									
		spi3_d0	3	IO									0
		vin1a_d13	7	I									0
		timer7	10	IO									
		gpio5_12	14	IO									
		Driver off	15	I									

Table 4-1. Pin Attributes<sup>(1)</sup> (continued)

BALL NUMBER [1]	BALL NAME [2]	SIGNAL NAME [3]	MUXMODE [4]	TYPE [5]	BALL RESET STATE [6]	BALL RESET REL. STATE [7]	BALL RESET REL. MUXMODE [8]	I/O VOLTAGE VALUE [9]	POWER [10]	HYS [11]	BUFFER TYPE [12]	PULL UP/DOWN TYPE [13]	DSIS [14]
B18	mcasep1_axr11	mcasep1_axr11	0	IO	PD	PD	15	1.8/3.3	vddshv3	Yes	Dual Voltage LVCMOS	PU/PD	0
		mcasep6_fsx	1	IO									0
		mcasep6_fsr	2	IO									
		spi3_cs0	3	IO									1
		vin1a_d12	7	I									0
		timer8	10	IO									
		gpio4_17	14	IO									
		Driver off	15	I									
A19	mcasep1_axr12	mcasep1_axr12	0	IO	PD	PD	15	1.8/3.3	vddshv3	Yes	Dual Voltage LVCMOS	PU/PD	0
		mcasep7_axr0	1	IO									0
		spi3_cs1	3	IO									1
		vin1a_d11	7	I									0
		timer9	10	IO									
		gpio4_18	14	IO									
		Driver off	15	I									
		E17	mcasep1_axr13	mcasep1_axr13									0
mcasep7_axr1	1			IO	0								
vin1a_d10	7			I	0								
timer10	10			IO									
gpio6_4	14			IO									
Driver off	15			I									
E16	mcasep1_axr14	mcasep1_axr14	0	IO	PD	PD	15	1.8/3.3	vddshv3	Yes	Dual Voltage LVCMOS	PU/PD	0
		mcasep7_acllx	1	IO									0
		mcasep7_aclkr	2	IO									
		vin1a_d9	7	I									0
		timer11	10	IO									
		gpio6_5	14	IO									
		Driver off	15	I									
F16	mcasep1_axr15	mcasep1_axr15	0	IO	PD	PD	15	1.8/3.3	vddshv3	Yes	Dual Voltage LVCMOS	PU/PD	0
		mcasep7_fsx	1	IO									0
		mcasep7_fsr	2	IO									
		vin1a_d8	7	I									0
		timer12	10	IO									
		gpio6_6	14	IO									
		Driver off	15	I									

Table 4-1. Pin Attributes<sup>(1)</sup> (continued)

BALL NUMBER [1]	BALL NAME [2]	SIGNAL NAME [3]	MUXMODE [4]	TYPE [5]	BALL RESET STATE [6]	BALL RESET REL. STATE [7]	BALL RESET REL. MUXMODE [8]	I/O VOLTAGE VALUE [9]	POWER [10]	HYS [11]	BUFFER TYPE [12]	PULL UP/DOWN TYPE [13]	DSIS [14]
D17	mcasep1_fsr	mcasep1_fsr	0	IO	PD	PD	15	1.8/3.3	vddshv3	Yes	Dual Voltage LVCMOS	PU/PD	0
		mcasep7_axr3	1	IO									0
		i2c4_scl	10	IO									1
		gpio5_1	14	IO									
		Driver off	15	I									
C17	mcasep1_fsx	mcasep1_fsx	0	IO	PD	PD	15	1.8/3.3	vddshv3	Yes	Dual Voltage LVCMOS	PU/PD	0
		vin1a_de0	7	I									0
		i2c3_scl	10	IO									1
		gpio7_30	14	IO									
		Driver off	15	I									
E19	mcasep2_aclcx	mcasep2_aclcx	0	IO	PD	PD	15	1.8/3.3	vddshv3	Yes	Dual Voltage LVCMOS	PU/PD	0
		vin1a_d7	7	I									0
		Driver off	15	I									
A20	mcasep2_axr0	mcasep2_axr0	0	IO	PD	PD	15	1.8/3.3	vddshv3	Yes	Dual Voltage LVCMOS	PU/PD	0
		Driver off	15	I									
B19	mcasep2_axr1	mcasep2_axr1	0	IO	PD	PD	15	1.8/3.3	vddshv3	Yes	Dual Voltage LVCMOS	PU/PD	0
		Driver off	15	I									
A21	mcasep2_axr2	mcasep2_axr2	0	IO	PD	PD	15	1.8/3.3	vddshv3	Yes	Dual Voltage LVCMOS	PU/PD	0
		mcasep3_axr2	1	IO									0
		vin1a_d5	7	I									0
		gpio6_8	14	IO									
		Driver off	15	I									
B21	mcasep2_axr3	mcasep2_axr3	0	IO	PD	PD	15	1.8/3.3	vddshv3	Yes	Dual Voltage LVCMOS	PU/PD	0
		mcasep3_axr3	1	IO									0
		vin1a_d4	7	I									0
		gpio6_9	14	IO									
		Driver off	15	I									
B20	mcasep2_axr4	mcasep2_axr4	0	IO	PD	PD	15	1.8/3.3	vddshv3	Yes	Dual Voltage LVCMOS	PU/PD	0
		mcasep8_axr0	1	IO									0
		gpio1_4	14	IO									
		Driver off	15	I									
C19	mcasep2_axr5	mcasep2_axr5	0	IO	PD	PD	15	1.8/3.3	vddshv3	Yes	Dual Voltage LVCMOS	PU/PD	0
		mcasep8_axr1	1	IO									0
		gpio6_7	14	IO									
		Driver off	15	I									

Table 4-1. Pin Attributes<sup>(1)</sup> (continued)

BALL NUMBER [1]	BALL NAME [2]	SIGNAL NAME [3]	MUXMODE [4]	TYPE [5]	BALL RESET STATE [6]	BALL RESET REL. STATE [7]	BALL RESET REL. MUXMODE [8]	I/O VOLTAGE VALUE [9]	POWER [10]	HYS [11]	BUFFER TYPE [12]	PULL UP/DOWN TYPE [13]	DSIS [14]
D20	mcasep2_axr6	mcasep2_axr6	0	IO	PD	PD	15	1.8/3.3	vddshv3	Yes	Dual Voltage LVCMOS	PU/PD	0
		mcasep8_aclkx	1	IO									0
		mcasep8_aclkr	2	IO									
		gpio2_29	14	IO									
		Driver off	15	I									
C20	mcasep2_axr7	mcasep2_axr7	0	IO	PD	PD	15	1.8/3.3	vddshv3	Yes	Dual Voltage LVCMOS	PU/PD	0
		mcasep8_fsx	1	IO									0
		mcasep8_fsr	2	IO									
		gpio1_5	14	IO									
		Driver off	15	I									
D19	mcasep2_fsx	mcasep2_fsx	0	IO	PD	PD	15	1.8/3.3	vddshv3	Yes	Dual Voltage LVCMOS	PU/PD	0
		vin1a_d6	7	I									0
		Driver off	15	I									
A22	mcasep3_aclkx	mcasep3_aclkx	0	IO	PD	PD	15	1.8/3.3	vddshv3	Yes	Dual Voltage LVCMOS	PU/PD	0
		mcasep3_aclkr	1	IO									
		mcasep2_axr12	2	IO									0
		uart7_rxd	3	I									1
		vin1a_d3	7	I									0
		gpio5_13	14	IO									
		Driver off	15	I									
B22	mcasep3_axr0	mcasep3_axr0	0	IO	PD	PD	15	1.8/3.3	vddshv3	Yes	Dual Voltage LVCMOS	PU/PD	0
		mcasep2_axr14	2	IO									0
		uart7_ctsn	3	I									1
		uart5_rxd	4	I									1
		vin1a_d1	7	I									0
		Driver off	15	I									
B23	mcasep3_axr1	mcasep3_axr1	0	IO	PD	PD	15	1.8/3.3	vddshv3	Yes	Dual Voltage LVCMOS	PU/PD	0
		mcasep2_axr15	2	IO									0
		uart7_rtsn	3	O									
		uart5_txd	4	O									
		vin1a_d0	7	I									0
		Driver off	15	I									



Table 4-1. Pin Attributes<sup>(1)</sup> (continued)

BALL NUMBER [1]	BALL NAME [2]	SIGNAL NAME [3]	MUXMODE [4]	TYPE [5]	BALL RESET STATE [6]	BALL RESET REL. STATE [7]	BALL RESET REL. MUXMODE [8]	I/O VOLTAGE VALUE [9]	POWER [10]	HYS [11]	BUFFER TYPE [12]	PULL UP/DOWN TYPE [13]	DSIS [14]
A23	mcasep3_fsx	mcasep3_fsx	0	IO	PD	PD	15	1.8/3.3	vddshv3	Yes	Dual Voltage LVCMOS	PU/PD	0
		mcasep3_fsr	1	IO									0
		mcasep2_axr13	2	IO									0
		uart7_txd	3	O									0
		vin1a_d2	7	I									0
		gpio5_14	14	IO									0
Driver off	15	I	0										
C23	mcasep4_aclkx	mcasep4_aclkx	0	IO	PD	PD	15	1.8/3.3	vddshv3	Yes	Dual Voltage LVCMOS	PU/PD	0
		mcasep4_aclkr	1	IO									0
		spi3_sclk	2	IO									1
		uart8_rxd	3	I									1
		i2c4_sda	4	IO									1
		Driver off	15	I									0
A24	mcasep4_axr0	mcasep4_axr0	0	IO	PD	PD	15	1.8/3.3	vddshv3	Yes	Dual Voltage LVCMOS	PU/PD	0
		spi3_d0	2	IO									0
		uart8_ctsn	3	I									1
		uart4_rxd	4	I									1
		i2c6_scl	14	IO									0
		Driver off	15	I									0
D23	mcasep4_axr1	mcasep4_axr1	0	IO	PD	PD	15	1.8/3.3	vddshv3	Yes	Dual Voltage LVCMOS	PU/PD	0
		spi3_cs0	2	IO									1
		uart8_rtsn	3	O									0
		uart4_txd	4	O									0
		i2c6_sda	14	IO									0
		Driver off	15	I									0
B25	mcasep4_fsx	mcasep4_fsx	0	IO	PD	PD	15	1.8/3.3	vddshv3	Yes	Dual Voltage LVCMOS	PU/PD	0
		mcasep4_fsr	1	IO									0
		spi3_d1	2	IO									0
		uart8_txd	3	O									0
		i2c4_scl	4	IO									1
		Driver off	15	I									0
AC3	mcasep5_aclkx	mcasep5_aclkx	0	IO	PD	PD	15	1.8/3.3	vddshv7	Yes	Dual Voltage LVCMOS	PU/PD	0
		mcasep5_aclkr	1	IO									0
		spi4_sclk	2	IO									0
		uart9_rxd	3	I									1
		i2c5_sda	4	IO									1
		Driver off	15	I									0

Table 4-1. Pin Attributes<sup>(1)</sup> (continued)

BALL NUMBER [1]	BALL NAME [2]	SIGNAL NAME [3]	MUXMODE [4]	TYPE [5]	BALL RESET STATE [6]	BALL RESET REL. STATE [7]	BALL RESET REL. MUXMODE [8]	I/O VOLTAGE VALUE [9]	POWER [10]	HYS [11]	BUFFER TYPE [12]	PULL UP/DOWN TYPE [13]	DSIS [14]
AA5	mcasep5_axr0	mcasep5_axr0	0	IO	PD	PD	15	1.8/3.3	vddshv7	Yes	Dual Voltage LVCMOS	PU/PD	0
		spi4_d0	2	IO									0
		uart9_ctsn	3	I									1
		uart3_rxd	4	I									1
		Driver off	15	I									
AC4	mcasep5_axr1	mcasep5_axr1	0	IO	PD	PD	15	1.8/3.3	vddshv7	Yes	Dual Voltage LVCMOS	PU/PD	0
		spi4_cs0	2	IO									1
		uart9_rtsn	3	O									
		uart3_txd	4	O									
		Driver off	15	I									
U6	mcasep5_fsx	mcasep5_fsx	0	IO	PD	PD	15	1.8/3.3	vddshv7	Yes	Dual Voltage LVCMOS	PU/PD	0
		mcasep5_fsr	1	IO									
		spi4_d1	2	IO									0
		uart9_txd	3	O									
		i2c5_scl	4	IO									1
Driver off	15	I											
L6	mdio_d	mdio_d	0	IO	PU	PU	15	1.8/3.3	vddshv9	Yes	Dual Voltage LVCMOS	PU/PD	1
		uart3_ctsn	1	I									1
		mii0_txer	3	O									0
		vin2a_d0	4	I									0
		vin1b_d0	5	I									0
		gpio5_16	14	IO									
		Driver off	15	I									
L5	mdio_mclk	mdio_mclk	0	O	PU	PU	15	1.8/3.3	vddshv9	Yes	Dual Voltage LVCMOS	PU/PD	1
		uart3_rtsn	1	O									
		mii0_col	3	I									0
		vin2a_clk0	4	I									
		vin1b_clk1	5	I									0
		gpio5_15	14	IO									
		Driver off	15	I									
U3	mmc1_clk	mmc1_clk	0	IO	PU	PU	15	1.8/3.3	vddshv8	Yes	SDIO2KV183 <sub>3</sub>	Pux/PDy	1
		gpio6_21	14	IO									
		Driver off	15	I									
V4	mmc1_cmd	mmc1_cmd	0	IO	PU	PU	15	1.8/3.3	vddshv8	Yes	SDIO2KV183 <sub>3</sub>	Pux/PDy	1
		gpio6_22	14	IO									
		Driver off	15	I									

Table 4-1. Pin Attributes<sup>(1)</sup> (continued)

BALL NUMBER [1]	BALL NAME [2]	SIGNAL NAME [3]	MUXMODE [4]	TYPE [5]	BALL RESET STATE [6]	BALL RESET REL. STATE [7]	BALL RESET REL. MUXMODE [8]	I/O VOLTAGE VALUE [9]	POWER [10]	HYS [11]	BUFFER TYPE [12]	PULL UP/DOWN TYPE [13]	DSIS [14]
V3	mmc1_dat0	mmc1_dat0	0	IO	PU	PU	15	1.8/3.3	vddshv8	Yes	SDIO2KV1833	Pux/PDy	1
		gpio6_23	14	IO									
		Driver off	15	I									
V2	mmc1_dat1	mmc1_dat1	0	IO	PU	PU	15	1.8/3.3	vddshv8	Yes	SDIO2KV1833	Pux/PDy	1
		gpio6_24	14	IO									
		Driver off	15	I									
W1	mmc1_dat2	mmc1_dat2	0	IO	PU	PU	15	1.8/3.3	vddshv8	Yes	SDIO2KV1833	Pux/PDy	1
		gpio6_25	14	IO									
		Driver off	15	I									
V1	mmc1_dat3	mmc1_dat3	0	IO	PU	PU	15	1.8/3.3	vddshv8	Yes	SDIO2KV1833	Pux/PDy	1
		gpio6_26	14	IO									
		Driver off	15	I									
U5	mmc1_sdcd	mmc1_sdcd	0	I	PU	PU	15	1.8/3.3	vddshv8	Yes	Dual Voltage LVCMOS	PU/PD	1
		uart6_rxd	3	I									1
		i2c4_sda	4	IO									1
		gpio6_27	14	IO									
		Driver off	15	I									
V5	mmc1_sdwp	mmc1_sdwp	0	I	PD	PD	15	1.8/3.3	vddshv8	Yes	Dual Voltage LVCMOS	PU/PD	0
		uart6_txd	3	O									
		i2c4_scl	4	IO									1
		gpio6_28	14	IO									
		Driver off	15	I									
Y2	mmc3_clk	mmc3_clk	0	IO	PU	PU	15	1.8/3.3	vddshv7	Yes	Dual Voltage LVCMOS	PU/PD	1
		usb3_ulpi_d5	3	IO									0
		vin2b_d7	4	I									0
		vin1a_d7	9	I									0
		ehrpwm2_tripzone_input	10	IO									0
		gpio6_29	14	IO									
		Driver off	15	I									
Y1	mmc3_cmd	mmc3_cmd	0	IO	PU	PU	15	1.8/3.3	vddshv7	Yes	Dual Voltage LVCMOS	PU/PD	1
		spi3_sclk	1	IO									0
		usb3_ulpi_d4	3	IO									0
		vin2b_d6	4	I									0
		vin1a_d6	9	I									0
		eCAP2_in_PWM2_out	10	IO									0
		gpio6_30	14	IO									
		Driver off	15	I									

Table 4-1. Pin Attributes<sup>(1)</sup> (continued)

BALL NUMBER [1]	BALL NAME [2]	SIGNAL NAME [3]	MUXMODE [4]	TYPE [5]	BALL RESET STATE [6]	BALL RESET REL. STATE [7]	BALL RESET REL. MUXMODE [8]	I/O VOLTAGE VALUE [9]	POWER [10]	HYS [11]	BUFFER TYPE [12]	PULL UP/DOWN TYPE [13]	DSIS [14]
Y4	mmc3_dat0	mmc3_dat0	0	IO	PU	PU	15	1.8/3.3	vddshv7	Yes	Dual Voltage LVCMOS	PU/PD	1
		spi3_d1	1	IO									0
		uart5_rxd	2	I									1
		usb3_ulpi_d3	3	IO									0
		vin2b_d5	4	I									0
		vin1a_d5	9	I									0
		eQEP3A_in	10	I									0
		gpio6_31	14	IO									
		Driver off	15	I									
AA2	mmc3_dat1	mmc3_dat1	0	IO	PU	PU	15	1.8/3.3	vddshv7	Yes	Dual Voltage LVCMOS	PU/PD	1
		spi3_d0	1	IO									0
		uart5_txd	2	O									
		usb3_ulpi_d2	3	IO									0
		vin2b_d4	4	I									0
		vin1a_d4	9	I									0
		eQEP3B_in	10	I									0
		gpio7_0	14	IO									
		Driver off	15	I									
AA3	mmc3_dat2	mmc3_dat2	0	IO	PU	PU	15	1.8/3.3	vddshv7	Yes	Dual Voltage LVCMOS	PU/PD	1
		spi3_cs0	1	IO									1
		uart5_ctsn	2	I									1
		usb3_ulpi_d1	3	IO									0
		vin2b_d3	4	I									0
		vin1a_d3	9	I									0
		eQEP3_index	10	IO									0
		gpio7_1	14	IO									
		Driver off	15	I									
W2	mmc3_dat3	mmc3_dat3	0	IO	PU	PU	15	1.8/3.3	vddshv7	Yes	Dual Voltage LVCMOS	PU/PD	1
		spi3_cs1	1	IO									1
		uart5_rtsn	2	O									
		usb3_ulpi_d0	3	IO									0
		vin2b_d2	4	I									0
		vin1a_d2	9	I									0
		eQEP3_strobe	10	IO									0
		gpio7_2	14	IO									
		Driver off	15	I									

Table 4-1. Pin Attributes<sup>(1)</sup> (continued)

BALL NUMBER [1]	BALL NAME [2]	SIGNAL NAME [3]	MUXMODE [4]	TYPE [5]	BALL RESET STATE [6]	BALL RESET REL. STATE [7]	BALL RESET REL. MUXMODE [8]	I/O VOLTAGE VALUE [9]	POWER [10]	HYS [11]	BUFFER TYPE [12]	PULL UP/DOWN TYPE [13]	DSIS [14]
Y3	mmc3_dat4	mmc3_dat4	0	IO	PU	PU	15	1.8/3.3	vddshv7	Yes	Dual Voltage LVCMOS	PU/PD	1
		spi4_sclk	1	IO									0
		uart10_rxd	2	I									1
		usb3_ulpi_nxt	3	I									0
		vin2b_d1	4	I									0
		vin1a_d1	9	I									0
		ehrpwm3A	10	O									
		gpio1_22	14	IO									
		Driver off	15	I									
AA1	mmc3_dat5	mmc3_dat5	0	IO	PU	PU	15	1.8/3.3	vddshv7	Yes	Dual Voltage LVCMOS	PU/PD	1
		spi4_d1	1	IO									0
		uart10_txd	2	O									
		usb3_ulpi_dir	3	I									0
		vin2b_d0	4	I									0
		vin1a_d0	9	I									0
		ehrpwm3B	10	O									
		gpio1_23	14	IO									
		Driver off	15	I									
AA4	mmc3_dat6	mmc3_dat6	0	IO	PU	PU	15	1.8/3.3	vddshv7	Yes	Dual Voltage LVCMOS	PU/PD	1
		spi4_d0	1	IO									0
		uart10_ctsn	2	I									1
		usb3_ulpi_stp	3	O									
		vin2b_de1	4	I									
		vin1a_hsync0	9	I									0
		ehrpwm3_tripzone_input	10	IO									0
		gpio1_24	14	IO									
		Driver off	15	I									
AB1	mmc3_dat7	mmc3_dat7	0	IO	PU	PU	15	1.8/3.3	vddshv7	Yes	Dual Voltage LVCMOS	PU/PD	1
		spi4_cs0	1	IO									1
		uart10_rtsn	2	O									
		usb3_ulpi_clk	3	I									0
		vin2b_clk1	4	I									
		vin1a_vsync0	9	I									0
		eCAP3_in_PWM3_out	10	IO									0
		gpio1_25	14	IO									
		Driver off	15	I									
L24	nmin_dsp	nmin_dsp	0	I	PD	PD		1.8/3.3	vddshv3	Yes	Dual Voltage LVCMOS	PU/PD	

Table 4-1. Pin Attributes<sup>(1)</sup> (continued)

BALL NUMBER [1]	BALL NAME [2]	SIGNAL NAME [3]	MUXMODE [4]	TYPE [5]	BALL RESET STATE [6]	BALL RESET REL. STATE [7]	BALL RESET REL. MUXMODE [8]	I/O VOLTAGE VALUE [9]	POWER [10]	HYS [11]	BUFFER TYPE [12]	PULL UP/DOWN TYPE [13]	DSIS [14]
AE6	pcie_rxn0	pcie_rxn0	0	I	OFF	OFF		1.8	vdda_pcie		SERDES		
AD7	pcie_rxp0	pcie_rxp0	0	I	OFF	OFF		1.8	vdda_pcie		SERDES		
AE8	pcie_txn0	pcie_txn0	0	O				1.8	vdda_pcie		SERDES		
AD9	pcie_txp0	pcie_txp0	0	O				1.8	vdda_pcie		SERDES		
F19	porz	porz	0	I				1.8/3.3	vddshv3	Yes	IHHV1833	PU/PD	
K24	resetrn	resetrn	0	I	PU	PU		1.8/3.3	vddshv3	Yes	Dual Voltage LVCMOS	PU/PD	
N2	rgmii0_rxc	rgmii0_rxc	0	I	PD	PD	15	1.8/3.3	vddshv9	Yes	Dual Voltage LVCMOS	PU/PD	0
		rmii1_txen	2	O									
		mii0_txclk	3	I									0
		vin2a_d5	4	I									0
		vin1b_d5	5	I									0
		usb3_ulpi_d2	6	IO									0
		gpio5_26	14	IO									
		Driver off	15	I									
P2	rgmii0_rxctl	rgmii0_rxctl	0	I	PD	PD	15	1.8/3.3	vddshv9	Yes	Dual Voltage LVCMOS	PU/PD	0
		rmii1_txd1	2	O									
		mii0_txd3	3	O									
		vin2a_d6	4	I									0
		vin1b_d6	5	I									0
		usb3_ulpi_d3	6	IO									0
		gpio5_27	14	IO									
		Driver off	15	I									
N4	rgmii0_rxd0	rgmii0_rxd0	0	I	PD	PD	15	1.8/3.3	vddshv9	Yes	Dual Voltage LVCMOS	PU/PD	0
		rmii0_txd0	1	O									
		mii0_txd0	3	O									
		vin2a_fld0	4	I									0
		vin1b_fld1	5	I									0
		usb3_ulpi_d7	6	IO									
		gpio5_31	14	IO									
		Driver off	15	I									
N3	rgmii0_rxd1	rgmii0_rxd1	0	I	PD	PD	15	1.8/3.3	vddshv9	Yes	Dual Voltage LVCMOS	PU/PD	0
		rmii0_txd1	1	O									
		mii0_txd1	3	O									
		vin2a_d9	4	I									0
		usb3_ulpi_d6	6	IO									0
		gpio5_30	14	IO									
		Driver off	15	I									

Table 4-1. Pin Attributes<sup>(1)</sup> (continued)

BALL NUMBER [1]	BALL NAME [2]	SIGNAL NAME [3]	MUXMODE [4]	TYPE [5]	BALL RESET STATE [6]	BALL RESET REL. STATE [7]	BALL RESET REL. MUXMODE [8]	I/O VOLTAGE VALUE [9]	POWER [10]	HYS [11]	BUFFER TYPE [12]	PULL UP/DOWN TYPE [13]	DSIS [14]										
P1	rgmii0_rxd2	rgmii0_rxd2	0	I	PD	PD	15	1.8/3.3	vddshv9	Yes	Dual Voltage LVCMOS	PU/PD	0										
		rmii0_txen	1	O																			
		mii0_txen	3	O																			
		vin2a_d8	4	I									0										
		usb3_ulpi_d5	6	IO									0										
		gpio5_29	14	IO																			
		Driver off	15	I																			
N1	rgmii0_rxd3	rgmii0_rxd3	0	I	PD	PD	15	1.8/3.3	vddshv9	Yes	Dual Voltage LVCMOS	PU/PD	0										
		rmii1_txd0	2	O																			
		mii0_txd2	3	O																			
		vin2a_d7	4	I									0										
		vin1b_d7	5	I									0										
		usb3_ulpi_d4	6	IO									0										
		gpio5_28	14	IO																			
Driver off	15	I																					
T4	rgmii0_txc	rgmii0_txc	0	O	PD	PD	15	1.8/3.3	vddshv9	Yes	Dual Voltage LVCMOS	PU/PD											
		uart3_ctsn	1	I									1										
		rmii1_rxd1	2	I									0										
		mii0_rxd3	3	I									0										
		vin2a_d3	4	I									0										
		vin1b_d3	5	I									0										
		usb3_ulpi_clk	6	I									0										
		spi3_d0	7	IO									0										
		spi4_cs2	8	IO									1										
		gpio5_20	14	IO																			
		Driver off	15	I																			
		T5	rgmii0_tctl	rgmii0_tctl									0	O	PD	PD	15	1.8/3.3	vddshv9	Yes	Dual Voltage LVCMOS	PU/PD	
				uart3_rtsn									1	O									
rmii1_rxd0	2			I	0																		
mii0_rxd2	3			I	0																		
vin2a_d4	4			I	0																		
vin1b_d4	5			I	0																		
usb3_ulpi_stp	6			O																			
spi3_cs0	7			IO	1																		
spi4_cs3	8			IO	1																		
gpio5_21	14			IO																			
Driver off	15			I																			

Table 4-1. Pin Attributes<sup>(1)</sup> (continued)

BALL NUMBER [1]	BALL NAME [2]	SIGNAL NAME [3]	MUXMODE [4]	TYPE [5]	BALL RESET STATE [6]	BALL RESET REL. STATE [7]	BALL RESET REL. MUXMODE [8]	I/O VOLTAGE VALUE [9]	POWER [10]	HYS [11]	BUFFER TYPE [12]	PULL UP/DOWN TYPE [13]	DSIS [14]
R1	rgmii0_txd0	rgmii0_txd0	0	O	PD	PD	15	1.8/3.3	vddshv9	Yes	Dual Voltage LVCMOS	PU/PD	
		rmii0_rxd0	1	I									0
		mii0_rxd0	3	I									0
		vin2a_d10	4	I									0
		usb3_ulpi_d1	6	IO									0
		spi4_cs0	7	IO									1
		uart4_rtsn	8	O									
		gpio5_25	14	IO									
		Driver off	15	I									
R2	rgmii0_txd1	rgmii0_txd1	0	O	PD	PD	15	1.8/3.3	vddshv9	Yes	Dual Voltage LVCMOS	PU/PD	
		rmii0_rxd1	1	I									0
		mii0_rxd1	3	I									0
		vin2a_vsync0	4	I									
		vin1b_vsync1	5	I									0
		usb3_ulpi_d0	6	IO									0
		spi4_d0	7	IO									0
		uart4_ctsn	8	IO									1
		gpio5_24	14	IO									
Driver off	15	I											
P3	rgmii0_txd2	rgmii0_txd2	0	O	PD	PD	15	1.8/3.3	vddshv9	Yes	Dual Voltage LVCMOS	PU/PD	
		rmii0_rxer	1	I									0
		mii0_rxer	3	I									0
		vin2a_hsync0	4	I									
		vin1b_hsync1	5	I									0
		usb3_ulpi_nxt	6	I									0
		spi4_d1	7	IO									0
		uart4_txd	8	O									
		gpio5_23	14	IO									
Driver off	15	I											



Table 4-1. Pin Attributes<sup>(1)</sup> (continued)

BALL NUMBER [1]	BALL NAME [2]	SIGNAL NAME [3]	MUXMODE [4]	TYPE [5]	BALL RESET STATE [6]	BALL RESET REL. STATE [7]	BALL RESET REL. MUXMODE [8]	I/O VOLTAGE VALUE [9]	POWER [10]	HYS [11]	BUFFER TYPE [12]	PULL UP/DOWN TYPE [13]	DSIS [14]	
P4	rgmii0_txd3	rgmii0_txd3	0	O	PD	PD	15	1.8/3.3	vddshv9	Yes	Dual Voltage LVCMOS	PU/PD		
		rmii0_crs	1	I									0	
		mii0_crs	3	I										0
		vin2a_de0	4	I										0
		vin1b_de1	5	I										0
		usb3_ulpi_dir	6	I										0
		spi4_sclk	7	IO										0
		uart4_rxd	8	I										1
		gpio5_22	14	IO										
		Driver off	15	I										
P5	RMII_MHZ_50_CLK	RMII_MHZ_50_CLK	0	IO	PD	PD	15	1.8/3.3	vddshv9	Yes	Dual Voltage LVCMOS	PU/PD	0	
		vin2a_d11	4	I									0	
		gpio5_17	14	IO										
		Driver off	15	I										
E20	rstoutn	rstoutn	0	O	PD	PD		1.8/3.3	vddshv3	Yes	Dual Voltage LVCMOS	PU/PD		
K25	rtck	rtck	0	O	PU	OFF	0	1.8/3.3	vddshv3	Yes	Dual Voltage LVCMOS	PU/PD		
		gpio8_29	14	IO										
B24	spi1_cs0	spi1_cs0	0	IO	PU	PU	15	1.8/3.3	vddshv3	Yes	Dual Voltage LVCMOS	PU/PD	1	
		gpio7_10	14	IO										
		Driver off	15	I										
C25	spi1_cs1	spi1_cs1	0	IO	PU	PU	15	1.8/3.3	vddshv3	Yes	Dual Voltage LVCMOS	PU/PD	1	
		spi2_cs1	3	IO									1	
		gpio7_11	14	IO										
		Driver off	15	I										
E24	spi1_cs2	spi1_cs2	0	IO	PU	PU	15	1.8/3.3	vddshv3	Yes	Dual Voltage LVCMOS	PU/PD	1	
		uart4_rxd	1	I									1	
		mmc3_sdcd	2	I									1	
		spi2_cs2	3	IO									1	
		dcan2_tx	4	IO									1	
		mdio_mclk	5	O									1	
		hdmi1_hpd	6	IO										
		gpio7_12	14	IO										
		Driver off	15	I										

**Table 4-1. Pin Attributes<sup>(1)</sup> (continued)**

BALL NUMBER [1]	BALL NAME [2]	SIGNAL NAME [3]	MUXMODE [4]	TYPE [5]	BALL RESET STATE [6]	BALL RESET REL. STATE [7]	BALL RESET REL. MUXMODE [8]	I/O VOLTAGE VALUE [9]	POWER [10]	HYS [11]	BUFFER TYPE [12]	PULL UP/DOWN TYPE [13]	DSIS [14]
E25	spi1_cs3	spi1_cs3	0	IO	PU	PU	15	1.8/3.3	vddshv3	Yes	Dual Voltage LVCMOS	PU/PD	1
		uart4_txd	1	O									0
		mmc3_sdwp	2	I									1
		spi2_cs3	3	IO									1
		dcan2_rx	4	IO									1
		mdio_d	5	IO									1
		hdmi1_cec	6	IO									
		gpio7_13	14	IO									
Driver off	15	I											
D25	spi1_d0	spi1_d0	0	IO	PD	PD	15	1.8/3.3	vddshv3	Yes	Dual Voltage LVCMOS	PU/PD	0
		gpio7_9	14	IO									
		Driver off	15	I									
D24	spi1_d1	spi1_d1	0	IO	PD	PD	15	1.8/3.3	vddshv3	Yes	Dual Voltage LVCMOS	PU/PD	0
		gpio7_8	14	IO									
		Driver off	15	I									
C24	spi1_sclk	spi1_sclk	0	IO	PD	PD	15	1.8/3.3	vddshv3	Yes	Dual Voltage LVCMOS	PU/PD	0
		gpio7_7	14	IO									
		Driver off	15	I									
F24	spi2_cs0	spi2_cs0	0	IO	PU	PU	15	1.8/3.3	vddshv3	Yes	Dual Voltage LVCMOS	PU/PD	1
		uart3_rtsn	1	O									
		uart5_txd	2	O									
		gpio7_17	14	IO									
		Driver off	15	I									
G24	spi2_d0	spi2_d0	0	IO	PD	PD	15	1.8/3.3	vddshv3	Yes	Dual Voltage LVCMOS	PU/PD	0
		uart3_ctsn	1	I									1
		uart5_rxd	2	I									1
		gpio7_16	14	IO									
		Driver off	15	I									
F25	spi2_d1	spi2_d1	0	IO	PD	PD	15	1.8/3.3	vddshv3	Yes	Dual Voltage LVCMOS	PU/PD	0
		uart3_txd	1	O									
		gpio7_15	14	IO									
		Driver off	15	I									
G25	spi2_sclk	spi2_sclk	0	IO	PD	PD	15	1.8/3.3	vddshv3	Yes	Dual Voltage LVCMOS	PU/PD	0
		uart3_rxd	1	I									1
		gpio7_14	14	IO									
		Driver off	15	I									
K21	tclk	tclk	0	I	PU	PU	0	1.8/3.3	vddshv3	Yes	IQ1833	PU/PD	

Table 4-1. Pin Attributes<sup>(1)</sup> (continued)

BALL NUMBER [1]	BALL NAME [2]	SIGNAL NAME [3]	MUXMODE [4]	TYPE [5]	BALL RESET STATE [6]	BALL RESET REL. STATE [7]	BALL RESET REL. MUXMODE [8]	I/O VOLTAGE VALUE [9]	POWER [10]	HYS [11]	BUFFER TYPE [12]	PULL UP/DOWN TYPE [13]	DSIS [14]
L23	tdi	tdi	0	I	PU	PU	0	1.8/3.3	vddshv3	Yes	Dual Voltage LVCMOS	PU/PD	
		gpio8_27	14	I									
J20	tdo	tdo	0	O	PU	PU	0	1.8/3.3	vddshv3	Yes	Dual Voltage LVCMOS	PU/PD	
		gpio8_28	14	IO									
L21	tms	tms	0	I	PU	PU	0	1.8/3.3	vddshv3	Yes	Dual Voltage LVCMOS	PU/PD	
L22	trstn	trstn	0	I	PD	PD		1.8/3.3	vddshv3	Yes	Dual Voltage LVCMOS	PU/PD	
L20	uart1_ctsn	uart1_ctsn	0	I	PU	PU	15	1.8/3.3	vddshv4	Yes	Dual Voltage LVCMOS	PU/PD	1
		uart9_rxd	2	I									1
		mmc4_clk	3	IO									1
		gpio7_24	14	IO									
		Driver off	15	I									
M24	uart1_rtsn	uart1_rtsn	0	O	PU	PU	15	1.8/3.3	vddshv4	Yes	Dual Voltage LVCMOS	PU/PD	
		uart9_txd	2	O									
		mmc4_cmd	3	IO									1
		gpio7_25	14	IO									
		Driver off	15	I									
L25	uart1_rxd	uart1_rxd	0	I	PU	PU	15	1.8/3.3	vddshv4	Yes	Dual Voltage LVCMOS	PU/PD	1
		mmc4_sdcd	3	I									1
		gpio7_22	14	IO									
		Driver off	15	I									
M25	uart1_txd	uart1_txd	0	O	PU	PU	15	1.8/3.3	vddshv4	Yes	Dual Voltage LVCMOS	PU/PD	
		mmc4_sdwlp	3	I									0
		gpio7_23	14	IO									
		Driver off	15	I									
N22	uart2_ctsn	uart2_ctsn	0	I	PU	PU	15	1.8/3.3	vddshv4	Yes	Dual Voltage LVCMOS	PU/PD	1
		uart3_rxd	2	I									1
		mmc4_dat2	3	IO									1
		uart10_rxd	4	I									1
		uart1_dtrn	5	O									
		gpio1_16	14	IO									
		Driver off	15	I									

Table 4-1. Pin Attributes<sup>(1)</sup> (continued)

BALL NUMBER [1]	BALL NAME [2]	SIGNAL NAME [3]	MUXMODE [4]	TYPE [5]	BALL RESET STATE [6]	BALL RESET REL. STATE [7]	BALL RESET REL. MUXMODE [8]	I/O VOLTAGE VALUE [9]	POWER [10]	HYS [11]	BUFFER TYPE [12]	PULL UP/DOWN TYPE [13]	DSIS [14]
N24	uart2_rtsn	uart2_rtsn	0	O	PU	PU	15	1.8/3.3	vddshv4	Yes	Dual Voltage LVCMOS	PU/PD	
		uart3_txd	1	O									
		uart3_irtx	2	O									
		mmc4_dat3	3	IO									1
		uart10_txd	4	O									
		uart1_rin	5	I									1
		gpio1_17	14	IO									
		Driver off	15	I									
N23	uart2_rxd	uart2_rxd	0	I	PU	PU	15	1.8/3.3	vddshv4	Yes	Dual Voltage LVCMOS	PU/PD	1
		uart3_ctsn	1	I									1
		uart3_rctx	2	O									
		mmc4_dat0	3	IO									1
		uart2_rxd	4	I									1
		uart1_dcdn	5	I									1
		gpio7_26	14	IO									
		Driver off	15	I									
N25	uart2_txd	uart2_txd	0	O	PU	PU	15	1.8/3.3	vddshv4	Yes	Dual Voltage LVCMOS	PU/PD	
		uart3_rtsn	1	O									
		uart3_sd	2	O									
		mmc4_dat1	3	IO									1
		uart2_txd	4	O									
		uart1_dsm	5	I									0
		gpio7_27	14	IO									
		Driver off	15	I									
N5	uart3_rxd	uart3_rxd	0	I	PD	PD	15	1.8/3.3	vddshv9	Yes	Dual Voltage LVCMOS	PU/PD	1
		rmii1_crs	2	I									0
		mii0_rxdv	3	I									0
		vin2a_d1	4	I									0
		vin1b_d1	5	I									0
		spi3_sclk	7	IO									0
		gpio5_18	14	IO									
		Driver off	15	I									

Table 4-1. Pin Attributes<sup>(1)</sup> (continued)

BALL NUMBER [1]	BALL NAME [2]	SIGNAL NAME [3]	MUXMODE [4]	TYPE [5]	BALL RESET STATE [6]	BALL RESET REL. STATE [7]	BALL RESET REL. MUXMODE [8]	I/O VOLTAGE VALUE [9]	POWER [10]	HYS [11]	BUFFER TYPE [12]	PULL UP/DOWN TYPE [13]	DSIS [14]	
N6	uart3_txd	uart3_txd	0	O	PD	PD	15	1.8/3.3	vddshv9	Yes	Dual Voltage LVCMOS	PU/PD		
		rmii1_rxer	2	I									0	
		mii0_rxclk	3	I										0
		vin2a_d2	4	I										0
		vin1b_d2	5	I										0
		spi3_d1	7	IO										0
		spi4_cs1	8	IO										1
		gpio5_19	14	IO										
		Driver off	15	I										
AB7	usb1_dm	usb1_dm	0	IO	OFF	OFF		3.3	vdda33v_usb1		USBPHY			
AC6	usb1_dp	usb1_dp	0	IO	OFF	OFF		3.3	vdda33v_usb1		USBPHY			
AD3	usb1_drvvbus	usb1_drvvbus	0	O	PD	PD	15	1.8/3.3	vdda33v_usb2	Yes	Dual Voltage LVCMOS	PU/PD		
		timer16	7	IO										
		gpio6_12	14	IO										
		Driver off	15	I										
AC5	usb2_dm	usb2_dm	0	IO				3.3	vdda33v_usb2	No	USBPHY			
AB6	usb2_dp	usb2_dp	0	IO				3.3	vdda33v_usb2	No	USBPHY			
AA6	usb2_drvvbus	usb2_drvvbus	0	O	PD	PD	15	1.8/3.3	vdda33v_usb2	Yes	Dual Voltage LVCMOS	PU/PD		
		timer15	7	IO										
		gpio6_13	14	IO										
		Driver off	15	I										
AE5	usb_rxn0	usb_rxn0	0	I	OFF	OFF		1.8	vdda_usb1		SERDES			
		pcie_rxn1	1	I										
AD6	usb_rxp0	usb_rxp0	0	I	OFF	OFF		1.8	vdda_usb1		SERDES			
		pcie_rxp1	1	I										
AE3	usb_txn0	usb_txn0	0	O				1.8	vdda_usb1		SERDES			
		pcie_txn1	1	O										
AD4	usb_txp0	usb_txp0	0	O				1.8	vdda_usb1		SERDES			
		pcie_txp1	1	O										

**Table 4-1. Pin Attributes<sup>(1)</sup> (continued)**

BALL NUMBER [1]	BALL NAME [2]	SIGNAL NAME [3]	MUXMODE [4]	TYPE [5]	BALL RESET STATE [6]	BALL RESET REL. STATE [7]	BALL RESET REL. MUXMODE [8]	I/O VOLTAGE VALUE [9]	POWER [10]	HYS [11]	BUFFER TYPE [12]	PULL UP/DOWN TYPE [13]	DSIS [14]
J15, J16, J18, K12, K18, L12, L17, M11, M13, M15, M17, N11, N13, N15, N18, P10, P12, P14, P16, P18, R10, R12, R14, R16, R17, T11, T13, T15, T17, T9, U11, U13, U15, U18, U9, V10, V12, V14, V16, V18, W10, W12, W14, W16	vdd	vdd		PWR									
F20	vpp	vpp <sup>(10)</sup>		PWR									
AA10	vdda33v_usb1	vdda33v_usb1		PWR									
Y10	vdda33v_usb2	vdda33v_usb2		PWR									
L9	vdda_core_gmac	vdda_core_gmac		PWR									
T6	vdda_csi	vdda_csi		PWR									
R20	vdda_ddr	vdda_ddr		PWR									
N10	vdda_debug	vdda_debug		PWR									
K10, L10	vdda_dsp_iva	vdda_dsp_iva		PWR									
N9	vdda_gpu	vdda_gpu		PWR									
W15, Y15	vdda_hdmi	vdda_hdmi		PWR									
K16, L16	vdda_mpu_abe	vdda_mpu_abe		PWR									
W13, Y13	vdda_osc	vdda_osc		PWR									
W11, Y11	vdda_pcie	vdda_pcie		PWR									
M10	vdda_per	vdda_per		PWR									
W8	vdda_usb1	vdda_usb1		PWR									
Y8	vdda_usb2	vdda_usb2		PWR									
Y9	vdda_usb3	vdda_usb3		PWR									
K14, L14	vdda_video	vdda_video		PWR									
G11, H20, W7, Y18	vdds18v	vdds18v		PWR									
AA19, P20, Y19	vdds18v_ddr1	vdds18v_ddr1		PWR									
G10, G9	vddshv1	vddshv1		PWR									
G15, G17, H15, H17, J19, K19	vddshv3	vddshv3		PWR									
M19, N19	vddshv4	vddshv4		PWR									
U7, U8	vddshv7	vddshv7		PWR									
N8, P8	vddshv8	vddshv8		PWR									
M7, N7	vddshv9	vddshv9		PWR									
J7, J8, K8	vddshv10	vddshv10		PWR									
F7, G7, H7	vddshv11	vddshv11		PWR									

Table 4-1. Pin Attributes<sup>(1)</sup> (continued)

BALL NUMBER [1]	BALL NAME [2]	SIGNAL NAME [3]	MUXMODE [4]	TYPE [5]	BALL RESET STATE [6]	BALL RESET REL. STATE [7]	BALL RESET REL. MUXMODE [8]	I/O VOLTAGE VALUE [9]	POWER [10]	HYS [11]	BUFFER TYPE [12]	PULL UP/DOWN TYPE [13]	DSIS [14]
T19, T20, V20, W17, W18, W20	vdds_dds1	vdds_dds1		PWR									
P7, R7	vdds_mlbp	vdds_mlbp		PWR									
H11, H13, H9, J11, J13, J9	vdd_dsp	vdd_dsp		PWR									
D8	vin2a_clk0	vin2a_clk0	0	I	PD	PD	15	1.8/3.3	vddshv1	Yes	Dual Voltage LVCMOS	PU/PD	
		vout2_fid	4	O									
		emu5	5	O									
		eQEP1A_in	10	I									0
		gpio3_28 gpmc_a27 gpmc_a17	14	IO									
		Driver off	15	I									
C8	vin2a_d0	vin2a_d0	0	I	PD	PD	15	1.8/3.3	vddshv1	Yes	Dual Voltage LVCMOS	PU/PD	0
		vout2_d23	4	O									
		emu10	5	O									
		uart9_ctsn	7	I									1
		spi4_d0	8	IO									0
		ehrpwm1B	10	O									
		gpio4_1	14	IO									
		Driver off	15	I									
B9	vin2a_d1	vin2a_d1	0	I	PD	PD	15	1.8/3.3	vddshv1	Yes	Dual Voltage LVCMOS	PU/PD	0
		vout2_d22	4	O									
		emu11	5	O									
		uart9_rtsn	7	O									
		spi4_cs0	8	IO									1
		ehrpwm1_tripzone_input	10	IO									0
		gpio4_2	14	IO									
		Driver off	15	I									
A7	vin2a_d2	vin2a_d2	0	I	PD	PD	15	1.8/3.3	vddshv1	Yes	Dual Voltage LVCMOS	PU/PD	0
		vout2_d21	4	O									
		emu12	5	O									
		uart10_rxd	8	I									1
		eCAP1_in_PWM1_out	10	IO									0
		gpio4_3	14	IO									
		Driver off	15	I									

Table 4-1. Pin Attributes<sup>(1)</sup> (continued)

BALL NUMBER [1]	BALL NAME [2]	SIGNAL NAME [3]	MUXMODE [4]	TYPE [5]	BALL RESET STATE [6]	BALL RESET REL. STATE [7]	BALL RESET REL. MUXMODE [8]	I/O VOLTAGE VALUE [9]	POWER [10]	HYS [11]	BUFFER TYPE [12]	PULL UP/DOWN TYPE [13]	DSIS [14]
A9	vin2a_d3	vin2a_d3	0	I	PD	PD	15	1.8/3.3	vddshv1	Yes	Dual Voltage LVCMOS	PU/PD	0
		vout2_d20	4	O									
		emu13	5	O									
		uart10_txd	8	O									
		ehrpwm1_synci	10	I									0
		gpio4_4	14	IO									
		Driver off	15	I									
A8	vin2a_d4	vin2a_d4	0	I	PD	PD	15	1.8/3.3	vddshv1	Yes	Dual Voltage LVCMOS	PU/PD	0
		vout2_d19	4	O									
		emu14	5	O									
		uart10_ctsn	8	I									1
		ehrpwm1_synco	10	O									
		gpio4_5	14	IO									
		Driver off	15	I									
A11	vin2a_d5	vin2a_d5	0	I	PD	PD	15	1.8/3.3	vddshv1	Yes	Dual Voltage LVCMOS	PU/PD	0
		vout2_d18	4	O									
		emu15	5	O									
		uart10_rtsn	8	O									
		eQEP2A_in	10	I									0
		gpio4_6	14	IO									
		Driver off	15	I									
F10	vin2a_d6	vin2a_d6	0	I	PD	PD	15	1.8/3.3	vddshv1	Yes	Dual Voltage LVCMOS	PU/PD	0
		vout2_d17	4	O									
		emu16	5	O									
		mii1_rxd1	8	I									0
		eQEP2B_in	10	I									0
		gpio4_7	14	IO									
		Driver off	15	I									
A10	vin2a_d7	vin2a_d7	0	I	PD	PD	15	1.8/3.3	vddshv1	Yes	Dual Voltage LVCMOS	PU/PD	0
		vout2_d16	4	O									
		emu17	5	O									
		mii1_rxd2	8	I									0
		eQEP2_index	10	IO									0
		gpio4_8	14	IO									
		Driver off	15	I									



Table 4-1. Pin Attributes<sup>(1)</sup> (continued)

BALL NUMBER [1]	BALL NAME [2]	SIGNAL NAME [3]	MUXMODE [4]	TYPE [5]	BALL RESET STATE [6]	BALL RESET REL. STATE [7]	BALL RESET REL. MUXMODE [8]	I/O VOLTAGE VALUE [9]	POWER [10]	HYS [11]	BUFFER TYPE [12]	PULL UP/DOWN TYPE [13]	DSIS [14]
B10	vin2a_d8	vin2a_d8	0	I	PD	PD	15	1.8/3.3	vddshv1	Yes	Dual Voltage LVCMOS	PU/PD	0
		vout2_d15	4	O									
		emu18	5	O									
		mii1_rxd3	8	I									0
		eQEP2_strobe	10	IO									0
		gpio4_9	14	IO									
		gpmc_a26	15	I									
E10	vin2a_d9	vin2a_d9	0	I	PD	PD	15	1.8/3.3	vddshv1	Yes	Dual Voltage LVCMOS	PU/PD	0
		vout2_d14	4	O									
		emu19	5	O									
		mii1_rxd0	8	I									0
		ehrpwm2A	10	O									
		gpio4_10	14	IO									
		gpmc_a25	15	I									
D10	vin2a_d10	vin2a_d10	0	I	PD	PD	15	1.8/3.3	vddshv1	Yes	Dual Voltage LVCMOS	PU/PD	0
		mdio_mclk	3	O									1
		vout2_d13	4	O									
		ehrpwm2B	10	O									
		gpio4_11	14	IO									
		gpmc_a24	15	I									
C10	vin2a_d11	vin2a_d11	0	I	PD	PD	15	1.8/3.3	vddshv1	Yes	Dual Voltage LVCMOS	PU/PD	0
		mdio_d	3	IO									1
		vout2_d12	4	O									
		ehrpwm2_tripzone_input	10	IO									0
		gpio4_12	14	IO									
		gpmc_a23	15	I									
B11	vin2a_d12	vin2a_d12	0	I	PD	PD	15	1.8/3.3	vddshv1	Yes	Dual Voltage LVCMOS	PU/PD	0
		rgmii1_txc	3	O									
		vout2_d11	4	O									
		mii1_rxclk	8	I									0
		eCAP2_in_PWM2_out	10	IO									0
		gpio4_13	14	IO									
		Driver off	15	I									

Table 4-1. Pin Attributes<sup>(1)</sup> (continued)

BALL NUMBER [1]	BALL NAME [2]	SIGNAL NAME [3]	MUXMODE [4]	TYPE [5]	BALL RESET STATE [6]	BALL RESET REL. STATE [7]	BALL RESET REL. MUXMODE [8]	I/O VOLTAGE VALUE [9]	POWER [10]	HYS [11]	BUFFER TYPE [12]	PULL UP/DOWN TYPE [13]	DSIS [14]
D11	vin2a_d13	vin2a_d13	0	I	PD	PD	15	1.8/3.3	vddshv1	Yes	Dual Voltage LVCMOS	PU/PD	0
		rgmii1_txctl	3	O									
		vout2_d10	4	O									
		mii1_rxdv	8	I									0
		eQEP3A_in	10	I									0
		gpio4_14	14	IO									
		Driver off	15	I									
C11	vin2a_d14	vin2a_d14	0	I	PD	PD	15	1.8/3.3	vddshv1	Yes	Dual Voltage LVCMOS	PU/PD	0
		rgmii1_txd3	3	O									
		vout2_d9	4	O									
		mii1_txclk	8	I									0
		eQEP3B_in	10	I									0
		gpio4_15	14	IO									
		Driver off	15	I									
B12	vin2a_d15	vin2a_d15	0	I	PD	PD	15	1.8/3.3	vddshv1	Yes	Dual Voltage LVCMOS	PU/PD	0
		rgmii1_txd2	3	O									
		vout2_d8	4	O									
		mii1_txd0	8	O									
		eQEP3_index	10	IO									0
		gpio4_16	14	IO									
		Driver off	15	I									
A12	vin2a_d16	vin2a_d16	0	I	PD	PD	15	1.8/3.3	vddshv1	Yes	Dual Voltage LVCMOS	PU/PD	0
		vin2b_d7	2	I									0
		rgmii1_txd1	3	O									
		vout2_d7	4	O									
		mii1_txd1	8	O									
		eQEP3_strobe	10	IO									0
		gpio4_24	14	IO									
Driver off	15	I											
A13	vin2a_d17	vin2a_d17	0	I	PD	PD	15	1.8/3.3	vddshv1	Yes	Dual Voltage LVCMOS	PU/PD	0
		vin2b_d6	2	I									0
		rgmii1_txd0	3	O									
		vout2_d6	4	O									
		mii1_txd2	8	O									
		ehrpwm3A	10	O									
		gpio4_25	14	IO									
Driver off	15	I											

Table 4-1. Pin Attributes<sup>(1)</sup> (continued)

BALL NUMBER [1]	BALL NAME [2]	SIGNAL NAME [3]	MUXMODE [4]	TYPE [5]	BALL RESET STATE [6]	BALL RESET REL. STATE [7]	BALL RESET REL. MUXMODE [8]	I/O VOLTAGE VALUE [9]	POWER [10]	HYS [11]	BUFFER TYPE [12]	PULL UP/DOWN TYPE [13]	DSIS [14]
E11	vin2a_d18	vin2a_d18	0	I	PD	PD	15	1.8/3.3	vddshv1	Yes	Dual Voltage LVCMOS	PU/PD	0
		vin2b_d5	2	I									0
		rgmii1_rxc	3	I									0
		vout2_d5	4	O									
		mii1_txd3	8	O									
		ehrpwm3B	10	O									
		gpio4_26	14	IO									
		Driver off	15	I									
F11	vin2a_d19	vin2a_d19	0	I	PD	PD	15	1.8/3.3	vddshv1	Yes	Dual Voltage LVCMOS	PU/PD	0
		vin2b_d4	2	I									0
		rgmii1_rxctl	3	I									0
		vout2_d4	4	O									
		mii1_txer	8	O									0
		ehrpwm3_tripzone_input	10	IO									0
		gpio4_27	14	IO									
		Driver off	15	I									
B13	vin2a_d20	vin2a_d20	0	I	PD	PD	15	1.8/3.3	vddshv1	Yes	Dual Voltage LVCMOS	PU/PD	0
		vin2b_d3	2	I									0
		rgmii1_rxd3	3	I									0
		vout2_d3	4	O									
		mii1_rxer	8	I									0
		eCAP3_in_PWM3_out	10	IO									0
		gpio4_28	14	IO									
		Driver off	15	I									
E13	vin2a_d21	vin2a_d21	0	I	PD	PD	15	1.8/3.3	vddshv1	Yes	Dual Voltage LVCMOS	PU/PD	0
		vin2b_d2	2	I									0
		rgmii1_rxd2	3	I									0
		vout2_d2	4	O									
		mii1_col	8	I									0
		gpio4_29	14	IO									
		Driver off	15	I									
C13	vin2a_d22	vin2a_d22	0	I	PD	PD	15	1.8/3.3	vddshv1	Yes	Dual Voltage LVCMOS	PU/PD	0
		vin2b_d1	2	I									0
		rgmii1_rxd1	3	I									0
		vout2_d1	4	O									
		mii1_crs	8	I									0
		gpio4_30	14	IO									
		Driver off	15	I									

Table 4-1. Pin Attributes<sup>(1)</sup> (continued)

BALL NUMBER [1]	BALL NAME [2]	SIGNAL NAME [3]	MUXMODE [4]	TYPE [5]	BALL RESET STATE [6]	BALL RESET REL. STATE [7]	BALL RESET REL. MUXMODE [8]	I/O VOLTAGE VALUE [9]	POWER [10]	HYS [11]	BUFFER TYPE [12]	PULL UP/DOWN TYPE [13]	DSIS [14]
D13	vin2a_d23	vin2a_d23	0	I	PD	PD	15	1.8/3.3	vddshv1	Yes	Dual Voltage LVCMOS	PU/PD	0
		vin2b_d0	2	I									0
		rgmii1_rxd0	3	I									0
		vout2_d0	4	O									
		mii1_txen	8	O									
		gpio4_31	14	IO									
		Driver off	15	I									
B7	vin2a_de0	vin2a_de0	0	I	PD	PD	15	1.8/3.3	vddshv1	Yes	Dual Voltage LVCMOS	PU/PD	
		vin2a_fid0	1	I									
		vin2b_fid1	2	I									
		vin2b_de1	3	I									
		vout2_de	4	O									
		emu6	5	O									
		eQEP1B_in	10	I									0
		gpio3_29	14	IO									
		Driver off	15	I									
C7	vin2a_fid0	vin2a_fid0	0	I	PD	PD	15	1.8/3.3	vddshv1	Yes	Dual Voltage LVCMOS	PU/PD	
		vin2b_clk1	2	I									
		vout2_clk	4	O									
		emu7	5	O									
		eQEP1_index	10	IO									0
		gpio3_30	14	IO									
		gpmc_a27											
		gpmc_a18											
Driver off	15	I											
E8	vin2a_hsync0	vin2a_hsync0	0	I	PD	PD	15	1.8/3.3	vddshv1	Yes	Dual Voltage LVCMOS	PU/PD	
		vin2b_hsync1	3	I									
		vout2_hsync	4	O									
		emu8	5	O									
		uart9_rxd	7	I									1
		spi4_sclk	8	IO									0
		eQEP1_strobe	10	IO									0
		gpio3_31	14	IO									
		gpmc_a27											
		Driver off	15	I									

Table 4-1. Pin Attributes<sup>(1)</sup> (continued)

BALL NUMBER [1]	BALL NAME [2]	SIGNAL NAME [3]	MUXMODE [4]	TYPE [5]	BALL RESET STATE [6]	BALL RESET REL. STATE [7]	BALL RESET REL. MUXMODE [8]	I/O VOLTAGE VALUE [9]	POWER [10]	HYS [11]	BUFFER TYPE [12]	PULL UP/DOWN TYPE [13]	DSIS [14]
B8	vin2a_vsync0	vin2a_vsync0	0	I	PD	PD	15	1.8/3.3	vddshv1	Yes	Dual Voltage LVCMOS	PU/PD	
		vin2b_vsync1	3	I									
		vout2_vsync	4	O									
		emu9	5	O									
		uart9_txd	7	O									
		spi4_d1	8	IO									0
		ehrpwm1A	10	O									
		gpio4_0	14	IO									
	Driver off	15	I										
A1, A25, AA13, AA15, AA7, AA8, AA9, AB8, AC13, AE1, AE15, AE25, G13, G16, G8, H10, H12, H14, H16, H18, H19, H8, J10, J12, J14, J17, K11, K13, K15, K17, K9, L11, L13, L15, L18, L8, M12, M14, M16, M18, M20, M8, M9, N12, N14, N16, N17, N20, P11, P13, P15, P17, P19, P9, R11, R13, R15, R18, R19, R8, R9, T10, T12, T14, T16, T18, T8, U10, U12, U14, U16, U17, U19, V11, V13, V15, V17, V19, V8, V9, W19, W9, Y14, Y16, Y17, Y7	vss	vss		GND									
AA12	vssa_osc0	vssa_osc0		GND									
AB11	vssa_osc1	vssa_osc1		GND									
AC10	Wakeup0	dcan1_rx	1	I			15	1.8/3.3	vdda33v_usb1	Yes	IHHV1833	PU/PD	1
		gpio1_0	14	I									
		sys_nirq2	15	I									
AB10	Wakeup3	sys_nirq1	1	I			15	1.8/3.3	vdda33v_usb1	Yes	IHHV1833	PU/PD	
		gpio1_3	14	I									
		dcan2_rx	15	I									
Y12	xi_osc0	xi_osc0	0	I			1.8	vdda_osc	No	LVCMOS Analog			
AC11	xi_osc1	xi_osc1	0	I			1.8	vdda_osc	No	LVCMOS Analog			
AB12	xo_osc0	xo_osc0	0	O			1.8	vdda_osc	No	LVCMOS Analog			

Table 4-1. Pin Attributes<sup>(1)</sup> (continued)

BALL NUMBER [1]	BALL NAME [2]	SIGNAL NAME [3]	MUXMODE [4]	TYPE [5]	BALL RESET STATE [6]	BALL RESET REL. STATE [7]	BALL RESET REL. MUXMODE [8]	I/O VOLTAGE VALUE [9]	POWER [10]	HYS [11]	BUFFER TYPE [12]	PULL UP/DOWN TYPE [13]	DSIS [14]	
AA11	xo_osc1	xo_osc1	0	A				1.8	vdda_osc	No	LVC MOS Analog			
J25	xref_clk0	xref_clk0	0	I	PD	PD	15	1.8/3.3	vddshv3	Yes	Dual Voltage LVC MOS	PU/PD		
		mcasp2_axr8	1	IO									0	
		mcasp1_axr4	2	IO										0
		mcasp1_ahclkx	3	O										
		mcasp5_ahclkx	4	O										
		vin1a_d0	7	I										0
		clkout2	9	O										
		timer13	10	IO										
		gpio6_17	14	IO										
Driver off	15	I												
J24	xref_clk1	xref_clk1	0	I	PD	PD	15	1.8/3.3	vddshv3	Yes	Dual Voltage LVC MOS	PU/PD		
		mcasp2_axr9	1	IO									0	
		mcasp1_axr5	2	IO									0	
		mcasp2_ahclkx	3	O										
		mcasp6_ahclkx	4	O										
		vin1a_clk0	7	I										0
		timer14	10	IO										
		gpio6_18	14	IO										
		Driver off	15	I										
H24	xref_clk2	xref_clk2	0	I	PD	PD	15	1.8/3.3	vddshv3	Yes	Dual Voltage LVC MOS	PU/PD		
		mcasp2_axr10	1	IO									0	
		mcasp1_axr6	2	IO									0	
		mcasp3_ahclkx	3	O										
		mcasp7_ahclkx	4	O										
		timer15	10	IO										
		gpio6_19	14	IO										
		Driver off	15	I										
H25	xref_clk3	xref_clk3	0	I	PD	PD	15	1.8/3.3	vddshv3	Yes	Dual Voltage LVC MOS	PU/PD		
		mcasp2_axr11	1	IO									0	
		mcasp1_axr7	2	IO									0	
		mcasp4_ahclkx	3	O										
		mcasp8_ahclkx	4	O										
		clkout3	9	O										
		timer16	10	IO										
		gpio6_20	14	IO										
		Driver off	15	I										

- (1) NA in this table stands for Not Applicable.
- (2) For more information on recommended operating conditions, see [Section 5.4, Recommended Operating Conditions](#).
- (3) The pullup or pulldown block strength is equal to: minimum = 50  $\mu$ A, typical = 100  $\mu$ A, maximum = 250  $\mu$ A.
- (4) The output impedance settings of this IO cell are programmable; by default, the value is DS[1:0] = 10, this means 40  $\Omega$ . For more information on DS[1:0] register configuration, see the Device TRM.
- (5) IO drive strength for usb1\_dp, usb1\_dm, usb2\_dp and usb2\_dm: minimum 18.3 mA, maximum 89 mA (for a power supply vdda33v\_usb1 and vdda33v\_usb2 = 3.46 V).
- (6) Minimum PU = 900  $\Omega$ , maximum PU = 3.090 k $\Omega$  and minimum PD = 14.25 k $\Omega$ , maximum PD = 24.8 k $\Omega$ .  
For more information, see chapter 7 of the USB2.0 specification, in particular section Signaling / Device Speed Identification.
- (7) This function will not be supported on some pin-compatible roadmap devices. Pin compatibility can be maintained in the future by not using these GPIO signals.
- (8) In PUX / PDY, x and y = 60 to 200  $\mu$ A.  
The output impedance settings (or drive strengths) of this IO are programmable (34  $\Omega$ , 40  $\Omega$ , 48  $\Omega$ , 60  $\Omega$ , 80  $\Omega$ ) depending on the values of the I[2:0] registers.
- (9) The internal pull resistors for balls A4, E7, D6, C5, D7, C6, A5, B6 are permanently disabled when sysboot15 is set to 0 as described in the section Sysboot Configuration of the Device TRM. If internal pull-up/down resistors are desired on these balls then sysboot15 should be set to 1. If gpmc boot mode is used with SYSBOOT15=0 (not recommended) then external pull-downs should be implemented to keep the address bus at logic-1 value during boot since the gpmc ms-address bits are high-z during boot.
- (10) This signal is valid only for High-Security devices. For more details, see [Section 5.8 VPP Specification for One-Time Programmable \(OTP\) eFUSES](#). For General Purpose devices do not connect any signal, test point, or board trace to this signal.

### 4.3 Signal Descriptions

Many signals are available on multiple pins, according to the software configuration of the pin multiplexing options.

1. **SIGNAL NAME:** The name of the signal passing through the pin.

---

#### NOTE

The subsystem multiplexing signals are not described in [Table 4-1](#) and [Table 4-27](#).

---

2. **DESCRIPTION:** Description of the signal
3. **TYPE:** Signal direction and type:
  - I = Input
  - O = Output
  - IO = Input or output
  - D = Open Drain
  - DS = Differential
  - A = Analog
  - PWR = Power
  - GND = Ground
4. **BALL:** Associated ball(s) bottom

---

#### NOTE

For more information, see the Control Module / Control Module Register Manual section of the device TRM.

---

#### 4.3.1 VIP

---

#### NOTE

For more information, see the Video Input Port (VIP) section of the device TRM.

---

**Table 4-2. VIP Signal Descriptions**

SIGNAL NAME	DESCRIPTION	TYPE	BALL
<b>Video Input 1</b>			
vin1a_clk0	Video Input 1 Port A Clock input. Input clock for 8-bit 16-bit or 24-bit Port A video capture. Input data is sampled on the CLK0 edge.	I	G3, J24, Y5
vin1a_d0	Video Input 1 Port A Data input	I	AA1, B23, F1, J25
vin1a_d1	Video Input 1 Port A Data input	I	B22, E2, Y3



**Table 4-2. VIP Signal Descriptions (continued)**

SIGNAL NAME	DESCRIPTION	TYPE	BALL
vin1a_d2	Video Input 1 Port A Data input	I	A23, E1, W2
vin1a_d3	Video Input 1 Port A Data input	I	A22, AA3, C1
vin1a_d4	Video Input 1 Port A Data input	I	AA2, B21, D1
vin1a_d5	Video Input 1 Port A Data input	I	A21, D2, Y4
vin1a_d6	Video Input 1 Port A Data input	I	B1, D19, Y1
vin1a_d7	Video Input 1 Port A Data input	I	B2, E19, Y2
vin1a_d8	Video Input 1 Port A Data input	I	C2, F16
vin1a_d9	Video Input 1 Port A Data input	I	D3, E16
vin1a_d10	Video Input 1 Port A Data input	I	A2, E17
vin1a_d11	Video Input 1 Port A Data input	I	A19, B3
vin1a_d12	Video Input 1 Port A Data input	I	B18, C3
vin1a_d13	Video Input 1 Port A Data input	I	B16, C4
vin1a_d14	Video Input 1 Port A Data input	I	A3, B17
vin1a_d15	Video Input 1 Port A Data input	I	A18, B4
vin1a_d16	Video Input 1 Port A Data input	I	M1
vin1a_d17	Video Input 1 Port A Data input	I	M2
vin1a_d18	Video Input 1 Port A Data input	I	L2
vin1a_d19	Video Input 1 Port A Data input	I	L1
vin1a_d20	Video Input 1 Port A Data input	I	K3
vin1a_d21	Video Input 1 Port A Data input	I	K2
vin1a_d22	Video Input 1 Port A Data input	I	J1
vin1a_d23	Video Input 1 Port A Data input	I	K1
vin1a_de0	Video Input 1 Port A Field ID input	I	C17, J2, Y6
vin1a_fld0	Video Input 1 Port A Field ID input	I	C16, L3
vin1a_hsync0	Video Input 1 Port A Horizontal Sync input	I	AA4, B14, K4
vin1a_vsync0	Video Input 1 Port A Vertical Sync input	I	AB1, D14, H1
vin1b_clk1	Video Input 1 Port B Clock input	I	J2, L5
vin1b_d0	Video Input 1 Port B Data input	I	L6, M1
vin1b_d1	Video Input 1 Port B Data input	I	M2, N5
vin1b_d2	Video Input 1 Port B Data input	I	L2, N6
vin1b_d3	Video Input 1 Port B Data input	I	L1, T4
vin1b_d4	Video Input 1 Port B Data input	I	K3, T5
vin1b_d5	Video Input 1 Port B Data input	I	K2, N2

Table 4-2. VIP Signal Descriptions (continued)

SIGNAL NAME	DESCRIPTION	TYPE	BALL
vin1b_d6	Video Input 1 Port B Data input	I	J1, P2
vin1b_d7	Video Input 1 Port B Data input	I	K1, N1
vin1b_de1	Video Input 1 Port B Field ID input	I	L3, P4
vin1b_fld1	Video Input 1 Port B Field ID input	I	G1, N4
vin1b_hsync1	Video Input 1 Port B Horizontal Sync input	I	K4, P3
vin1b_vsync1	Video Input 1 Port B Vertical Sync input	I	H1, R2
<b>Video Input 2</b>			
vin2a_clk0	Video Input 2 Port A Clock input.	I	D8, L5
vin2a_d0	Video Input 2 Port A Data input	I	C8, L6
vin2a_d1	Video Input 2 Port A Data input	I	B9, N5
vin2a_d2	Video Input 2 Port A Data input	I	A7, N6
vin2a_d3	Video Input 2 Port A Data input	I	A9, T4
vin2a_d4	Video Input 2 Port A Data input	I	A8, T5
vin2a_d5	Video Input 2 Port A Data input	I	A11, N2
vin2a_d6	Video Input 2 Port A Data input	I	F10, P2
vin2a_d7	Video Input 2 Port A Data input	I	A10, N1
vin2a_d8	Video Input 2 Port A Data input	I	B10, P1
vin2a_d9	Video Input 2 Port A Data input	I	E10, N3
vin2a_d10	Video Input 2 Port A Data input	I	D10, R1
vin2a_d11	Video Input 2 Port A Data input	I	C10, P5
vin2a_d12	Video Input 2 Port A Data input	I	B11
vin2a_d13	Video Input 2 Port A Data input	I	D11
vin2a_d14	Video Input 2 Port A Data input	I	C11
vin2a_d15	Video Input 2 Port A Data input	I	B12
vin2a_d16	Video Input 2 Port A Data input	I	A12
vin2a_d17	Video Input 2 Port A Data input	I	A13
vin2a_d18	Video Input 2 Port A Data input	I	E11
vin2a_d19	Video Input 2 Port A Data input	I	F11
vin2a_d20	Video Input 2 Port A Data input	I	B13
vin2a_d21	Video Input 2 Port A Data input	I	E13
vin2a_d22	Video Input 2 Port A Data input	I	C13
vin2a_d23	Video Input 2 Port A Data input	I	D13
vin2a_de0	Video Input 2 Port A Field ID input	I	B7, P4

**Table 4-2. VIP Signal Descriptions (continued)**

SIGNAL NAME	DESCRIPTION	TYPE	BALL
vin2a_fld0	Video Input 2 Port A Field ID input	I	B7, C7, N4
vin2a_hsync0	Video Input 2 Port A Horizontal Sync input	I	E8, P3
vin2a_vsync0	Video Input 2 Port A Vertical Sync input	I	B8, R2
vin2b_clk1	Video Input 2 Port B Clock input	I	AB1, C7, L4, H6
vin2b_d0	Video Input 2 Port B Data input	I	AA1, D13, A4
vin2b_d1	Video Input 2 Port B Data input	I	C13, Y3, E7
vin2b_d2	Video Input 2 Port B Data input	I	E13, W2, D6
vin2b_d3	Video Input 2 Port B Data input	I	AA3, B13, C5
vin2b_d4	Video Input 2 Port B Data input	I	AA2, F11, B5
vin2b_d5	Video Input 2 Port B Data input	I	E11, Y4, D7
vin2b_d6	Video Input 2 Port B Data input	I	A13, Y1, C6
vin2b_d7	Video Input 2 Port B Data input	I	A12, Y2, A5
vin2b_de1	Video Input 2 Port B Field ID input	I	AA4, B7, H2
vin2b_fld1	Video Input 2 Port B Field ID input	I	B7, H6
vin2b_hsync1	Video Input 2 Port B Horizontal Sync input	I	E8, Y5, B6
vin2b_vsync1	Video Input 2 Port B Vertical Sync input	I	B8, Y6, A6

### 4.3.2 DSS

**Table 4-3. DSS Signal Descriptions**

SIGNAL NAME	DESCRIPTION	TYPE	BALL
<b>DPI Video Output 2</b>			
vout2_clk	Video Output 2 Clock output	O	C7
vout2_d0	Video Output 2 Data output	O	D13
vout2_d1	Video Output 2 Data output	O	C13
vout2_d2	Video Output 2 Data output	O	E13
vout2_d3	Video Output 2 Data output	O	B13
vout2_d4	Video Output 2 Data output	O	F11
vout2_d5	Video Output 2 Data output	O	E11
vout2_d6	Video Output 2 Data output	O	A13
vout2_d7	Video Output 2 Data output	O	A12
vout2_d8	Video Output 2 Data output	O	B12
vout2_d9	Video Output 2 Data output	O	C11
vout2_d10	Video Output 2 Data output	O	D11
vout2_d11	Video Output 2 Data output	O	B11
vout2_d12	Video Output 2 Data output	O	C10
vout2_d13	Video Output 2 Data output	O	D10
vout2_d14	Video Output 2 Data output	O	E10
vout2_d15	Video Output 2 Data output	O	B10
vout2_d16	Video Output 2 Data output	O	A10
vout2_d17	Video Output 2 Data output	O	F10
vout2_d18	Video Output 2 Data output	O	A11
vout2_d19	Video Output 2 Data output	O	A8
vout2_d20	Video Output 2 Data output	O	A9
vout2_d21	Video Output 2 Data output	O	A7
vout2_d22	Video Output 2 Data output	O	B9
vout2_d23	Video Output 2 Data output	O	C8
vout2_de	Video Output 2 Data Enable output	O	B7
vout2_fld	Video Output 2 Field ID output. This signal is not used for embedded sync modes.	O	D8
vout2_hsync	Video Output 2 Horizontal Sync output. This signal is not used for embedded sync modes.	O	E8
vout2_vsync	Video Output 2 Vertical Sync output. This signal is not used for embedded sync modes.	O	B8
<b>DPI Video Output 3</b>			
vout3_clk	Video Output 3 Clock output	O	G3
vout3_d0	Video Output 3 Data output	O	F1
vout3_d1	Video Output 3 Data output	O	E2
vout3_d2	Video Output 3 Data output	O	E1
vout3_d3	Video Output 3 Data output	O	C1
vout3_d4	Video Output 3 Data output	O	D1
vout3_d5	Video Output 3 Data output	O	D2
vout3_d6	Video Output 3 Data output	O	B1
vout3_d7	Video Output 3 Data output	O	B2
vout3_d8	Video Output 3 Data output	O	C2
vout3_d9	Video Output 3 Data output	O	D3
vout3_d10	Video Output 3 Data output	O	A2
vout3_d11	Video Output 3 Data output	O	B3

**Table 4-3. DSS Signal Descriptions (continued)**

SIGNAL NAME	DESCRIPTION	TYPE	BALL
vout3_d12	Video Output 3 Data output	O	C3
vout3_d13	Video Output 3 Data output	O	C4
vout3_d14	Video Output 3 Data output	O	A3
vout3_d15	Video Output 3 Data output	O	B4
vout3_d16	Video Output 3 Data output	O	M1
vout3_d17	Video Output 3 Data output	O	M2
vout3_d18	Video Output 3 Data output	O	L2
vout3_d19	Video Output 3 Data output	O	L1
vout3_d20	Video Output 3 Data output	O	K3
vout3_d21	Video Output 3 Data output	O	K2
vout3_d22	Video Output 3 Data output	O	J1
vout3_d23	Video Output 3 Data output	O	K1
vout3_de	Video Output 3 Data Enable output	O	J2
vout3_fld	Video Output 3 Field ID output. This signal is not used for embedded sync modes.	O	L3
vout3_hsync	Video Output 3 Horizontal Sync output. This signal is not used for embedded sync modes.	O	K4
vout3_vsync	Video Output 3 Vertical Sync output. This signal is not used for embedded sync modes.	O	H1

### 4.3.3 HDMI

---

**NOTE**

For more information, see the Display Subsystem / Display Subsystem Overview of the device TRM.

---

**Table 4-4. HDMI Signal Descriptions**

SIGNAL NAME	DESCRIPTION	TYPE	BALL
hdmi1_cec	HDMI consumer electronic control	IOD	E25, H23
hdmi1_hpd	HDMI display hot plug detect	IO	E24, H22
hdmi1_ddc_scl	HDMI display data channel clock	IOD	F23
hdmi1_ddc_sda	HDMI display data channel data	IOD	G21
hdmi1_clockx	HDMI clock differential positive or negative	ODS	AE9
hdmi1_clocky	HDMI clock differential positive or negative	ODS	AD10
hdmi1_data2x	HDMI data 2 differential positive or negative	ODS	AE14
hdmi1_data2y	HDMI data 2 differential positive or negative	ODS	AD15
hdmi1_data1x	HDMI data 1 differential positive or negative	ODS	AE12
hdmi1_data1y	HDMI data 1 differential positive or negative	ODS	AD13
hdmi1_data0x	HDMI data 0 differential positive or negative	ODS	AE11
hdmi1_data0y	HDMI data 0 differential positive or negative	ODS	AD12

### 4.3.4 CSI2

---

**NOTE**

For more information, see the CAL Subsystem / CAL Subsystem Overview of the device TRM.

---

**Table 4-5. CSI 2 Signal Descriptions**

SIGNAL NAME	DESCRIPTION	TYPE	BALL
csi2_0_dx0	Serial data/clock input - line 0 (position 1)	I	AC1
csi2_0_dy0	Serial data/clock input - line 0 (position 1)	I	AB2
csi2_0_dx1	Serial data/clock input - line 1 (position 2)	I	AD1
csi2_0_dy1	Serial data/clock input - line 1 (position 2)	I	AC2
csi2_0_dx2	Serial data/clock input - line 2 (position 3)	I	AE2
csi2_0_dy2	Serial data/clock input - line 2 (position 3)	I	AD2

**4.3.5 EMIF****NOTE**

For more information, see the Memory Subsystem / EMIF Controller section of the device TRM.

**NOTE**

The index number 1 which is part of the EMIF1 signal prefixes (ddr1\_\*) listed in [Table 4-6](#), EMIF Signal Descriptions, column "SIGNAL NAME" not to be confused with DDR1 type of SDRAM memories.

**Table 4-6. EMIF Signal Descriptions**

SIGNAL NAME	DESCRIPTION	TYPE	BALL
ddr1_csn0	EMIF1 Chip Select 0	O	AC19
ddr1_cke	EMIF1 Clock Enable	O	AB18
ddr1_ck	EMIF1 Clock	O	AD21
ddr1_nck	EMIF1 Negative Clock	O	AE21
ddr1_odt0	EMIF1 On-Die Termination for Chip Select 0	O	AD18
ddr1_casn	EMIF1 Column Address Strobe	O	AD16
ddr1_rasn	EMIF1 Row Address Strobe	O	AD17
ddr1_wen	EMIF1 Write Enable	O	AE18
ddr1_rst	EMIF1 Reset output (DDR3-SDRAM only)	O	AE17
ddr1_ba0	EMIF1 Bank Address	O	AE16
ddr1_ba1	EMIF1 Bank Address	O	AA16
ddr1_ba2	EMIF1 Bank Address	O	AB16
ddr1_a0	EMIF1 Address Bus	O	AC18
ddr1_a1	EMIF1 Address Bus	O	AE19
ddr1_a2	EMIF1 Address Bus	O	AD19
ddr1_a3	EMIF1 Address Bus	O	AB19
ddr1_a4	EMIF1 Address Bus	O	AD20
ddr1_a5	EMIF1 Address Bus	O	AE20
ddr1_a6	EMIF1 Address Bus	O	AA18
ddr1_a7	EMIF1 Address Bus	O	AA20
ddr1_a8	EMIF1 Address Bus	O	Y21
ddr1_a9	EMIF1 Address Bus	O	AC20
ddr1_a10	EMIF1 Address Bus	O	AA21
ddr1_a11	EMIF1 Address Bus	O	AC21
ddr1_a12	EMIF1 Address Bus	O	AC22
ddr1_a13	EMIF1 Address Bus	O	AC15

**Table 4-6. EMIF Signal Descriptions (continued)**

SIGNAL NAME	DESCRIPTION	TYPE	BALL
ddr1_a14	EMIF1 Address Bus	O	AB15
ddr1_a15	EMIF1 Address Bus	O	AC16
ddr1_d0	EMIF1 Data Bus	IO	AA23
ddr1_d1	EMIF1 Data Bus	IO	AC24
ddr1_d2	EMIF1 Data Bus	IO	AB24
ddr1_d3	EMIF1 Data Bus	IO	AD24
ddr1_d4	EMIF1 Data Bus	IO	AB23
ddr1_d5	EMIF1 Data Bus	IO	AC23
ddr1_d6	EMIF1 Data Bus	IO	AD23
ddr1_d7	EMIF1 Data Bus	IO	AE24
ddr1_d8	EMIF1 Data Bus	IO	AA24
ddr1_d9	EMIF1 Data Bus	IO	W25
ddr1_d10	EMIF1 Data Bus	IO	Y23
ddr1_d11	EMIF1 Data Bus	IO	AD25
ddr1_d12	EMIF1 Data Bus	IO	AC25
ddr1_d13	EMIF1 Data Bus	IO	AB25
ddr1_d14	EMIF1 Data Bus	IO	AA25
ddr1_d15	EMIF1 Data Bus	IO	W24
ddr1_d16	EMIF1 Data Bus	IO	W23
ddr1_d17	EMIF1 Data Bus	IO	U25
ddr1_d18	EMIF1 Data Bus	IO	U24
ddr1_d19	EMIF1 Data Bus	IO	W21
ddr1_d20	EMIF1 Data Bus	IO	T22
ddr1_d21	EMIF1 Data Bus	IO	U22
ddr1_d22	EMIF1 Data Bus	IO	U23
ddr1_d23	EMIF1 Data Bus	IO	T21
ddr1_d24	EMIF1 Data Bus	IO	T23
ddr1_d25	EMIF1 Data Bus	IO	T25
ddr1_d26	EMIF1 Data Bus	IO	T24
ddr1_d27	EMIF1 Data Bus	IO	P21
ddr1_d28	EMIF1 Data Bus	IO	N21
ddr1_d29	EMIF1 Data Bus	IO	P22
ddr1_d30	EMIF1 Data Bus	IO	P23
ddr1_d31	EMIF1 Data Bus	IO	P24
ddr1_dqm0	EMIF1 Data Mask	O	AE23
ddr1_dqm1	EMIF1 Data Mask	O	W22
ddr1_dqm2	EMIF1 Data Mask	O	U21
ddr1_dqm3	EMIF1 Data Mask	O	P25
ddr1_dqs0	Data strobe 0 input/output for byte 0 of the 32-bit data bus. This signal is output to the EMIF1 memory when writing and input when reading.	IO	AD22
ddr1_dqsn0	Data strobe 0 invert	IO	AE22
ddr1_dqs1	Data strobe 1 input/output for byte 1 of the 32-bit data bus. This signal is output to the EMIF1 memory when writing and input when reading.	IO	Y24
ddr1_dqsn1	Data strobe 1 invert	IO	Y25
ddr1_dqs2	Data strobe 2 input/output for byte 2 of the 32-bit data bus. This signal is output to the EMIF1 memory when writing and input when reading.	IO	V24
ddr1_dqsn2	Data strobe 2 invert	IO	V25

**Table 4-6. EMIF Signal Descriptions (continued)**

SIGNAL NAME	DESCRIPTION	TYPE	BALL
ddr1_dqs3	Data strobe 3 input/output for byte 3 of the 32-bit data bus. This signal is output to the EMIF1 memory when writing and input when reading.	IO	R24
ddr1_dqsn3	Data strobe 3 invert	IO	R25
ddr1_vref0	Reference Power Supply EMIF1	A	Y20

### 4.3.6 GPMC

#### NOTE

For more information, see the Memory Subsystem / General-Purpose Memory Controller section of the device TRM.

**Table 4-7. GPMC Signal Descriptions**

SIGNAL NAME	DESCRIPTION	TYPE	BALL
gpmc_ad0	GPMC Data 0 in A/D nonmultiplexed mode and additionally Address 1 in A/D multiplexed mode	IO	F1
gpmc_ad1	GPMC Data 1 in A/D nonmultiplexed mode and additionally Address 2 in A/D multiplexed mode	IO	E2
gpmc_ad2	GPMC Data 2 in A/D nonmultiplexed mode and additionally Address 3 in A/D multiplexed mode	IO	E1
gpmc_ad3	GPMC Data 3 in A/D nonmultiplexed mode and additionally Address 4 in A/D multiplexed mode	IO	C1
gpmc_ad4	GPMC Data 4 in A/D nonmultiplexed mode and additionally Address 5 in A/D multiplexed mode	IO	D1
gpmc_ad5	GPMC Data 5 in A/D nonmultiplexed mode and additionally Address 6 in A/D multiplexed mode	IO	D2
gpmc_ad6	GPMC Data 6 in A/D nonmultiplexed mode and additionally Address 7 in A/D multiplexed mode	IO	B1
gpmc_ad7	GPMC Data 7 in A/D nonmultiplexed mode and additionally Address 8 in A/D multiplexed mode	IO	B2
gpmc_ad8	GPMC Data 8 in A/D nonmultiplexed mode and additionally Address 9 in A/D multiplexed mode	IO	C2
gpmc_ad9	GPMC Data 9 in A/D nonmultiplexed mode and additionally Address 10 in A/D multiplexed mode	IO	D3
gpmc_ad10	GPMC Data 10 in A/D nonmultiplexed mode and additionally Address 11 in A/D multiplexed mode	IO	A2
gpmc_ad11	GPMC Data 11 in A/D nonmultiplexed mode and additionally Address 12 in A/D multiplexed mode	IO	B3
gpmc_ad12	GPMC Data 12 in A/D nonmultiplexed mode and additionally Address 13 in A/D multiplexed mode	IO	C3
gpmc_ad13	GPMC Data 13 in A/D nonmultiplexed mode and additionally Address 14 in A/D multiplexed mode	IO	C4
gpmc_ad14	GPMC Data 14 in A/D nonmultiplexed mode and additionally Address 15 in A/D multiplexed mode	IO	A3
gpmc_ad15	GPMC Data 15 in A/D nonmultiplexed mode and additionally Address 16 in A/D multiplexed mode	IO	B4
gpmc_a0	GPMC Address 0. Only used to effectively address 8-bit data nonmultiplexed memories	O	G1, M1
gpmc_a1	GPMC address 1 in A/D nonmultiplexed mode and Address 17 in A/D multiplexed mode	O	G3, M2
gpmc_a2	GPMC address 2 in A/D nonmultiplexed mode and Address 18 in A/D multiplexed mode	O	H5, L2
gpmc_a3	GPMC address 3 in A/D nonmultiplexed mode and Address 19 in A/D multiplexed mode	O	H6, L1



**Table 4-7. GPMC Signal Descriptions (continued)**

SIGNAL NAME	DESCRIPTION	TYPE	BALL
gpmc_a4	GPMC address 4 in A/D nonmultiplexed mode and Address 20 in A/D multiplexed mode	O	K3
gpmc_a5	GPMC address 5 in A/D nonmultiplexed mode and Address 21 in A/D multiplexed mode	O	K2
gpmc_a6	GPMC address 6 in A/D nonmultiplexed mode and Address 22 in A/D multiplexed mode	O	J1
gpmc_a7	GPMC address 7 in A/D nonmultiplexed mode and Address 23 in A/D multiplexed mode	O	K1
gpmc_a8	GPMC address 8 in A/D nonmultiplexed mode and Address 24 in A/D multiplexed mode	O	K4
gpmc_a9	GPMC address 9 in A/D nonmultiplexed mode and Address 25 in A/D multiplexed mode	O	H1
gpmc_a10	GPMC address 10 in A/D nonmultiplexed mode and Address 26 in A/D multiplexed mode	O	J2
gpmc_a11	GPMC address 11 in A/D nonmultiplexed mode and unused in A/D multiplexed mode	O	L3
gpmc_a12	GPMC address 12 in A/D nonmultiplexed mode and unused in A/D multiplexed mode	O	G1
gpmc_a13	GPMC address 13 in A/D nonmultiplexed mode and unused in A/D multiplexed mode	O	A4, H3, G4
gpmc_a14	GPMC address 14 in A/D nonmultiplexed mode and unused in A/D multiplexed mode	O	E7, H4, G3
gpmc_a15	GPMC address 15 in A/D nonmultiplexed mode and unused in A/D multiplexed mode	O	D6, K6, F6
gpmc_a16	GPMC address 16 in A/D nonmultiplexed mode and unused in A/D multiplexed mode	O	C5, K5, M1
gpmc_a17	GPMC address 17 in A/D nonmultiplexed mode and unused in A/D multiplexed mode	O	B5, G2, D8
gpmc_a18	GPMC address 18 in A/D nonmultiplexed mode and unused in A/D multiplexed mode	O	D7, F2, C7
gpmc_a19	GPMC address 19 in A/D nonmultiplexed mode and unused in A/D multiplexed mode	O	A4 <sup>(3)</sup> , C6, H5
gpmc_a20	GPMC address 20 in A/D nonmultiplexed mode and unused in A/D multiplexed mode	O	A5, E7 <sup>(3)</sup> , L4
gpmc_a21	GPMC address 21 in A/D nonmultiplexed mode and unused in A/D multiplexed mode	O	B6, D6 <sup>(3)</sup> , H2
gpmc_a22	GPMC address 22 in A/D nonmultiplexed mode and unused in A/D multiplexed mode	O	A6, C5 <sup>(3)</sup> , H6
gpmc_a23	GPMC address 23 in A/D nonmultiplexed mode and unused in A/D multiplexed mode	O	B5, H5, C10, G4
gpmc_a24	GPMC address 24 in A/D nonmultiplexed mode and unused in A/D multiplexed mode	O	D7 <sup>(3)</sup> , D10, G3
gpmc_a25	GPMC address 25 in A/D nonmultiplexed mode and unused in A/D multiplexed mode	O	C6 <sup>(3)</sup> , F6, E10
gpmc_a26	GPMC address 26 in A/D nonmultiplexed mode and unused in A/D multiplexed mode	O	A5 <sup>(3)</sup> , M1, B10
gpmc_a27	GPMC address 27 in A/D nonmultiplexed mode and Address 27 in A/D multiplexed mode	O	B6 <sup>(3)</sup> , D8, C7, E8
gpmc_cs0	GPMC Chip Select 0 (active low)	O	F3
gpmc_cs1	GPMC Chip Select 1 (active low)	O	A6
gpmc_cs2	GPMC Chip Select 2 (active low)	O	G4
gpmc_cs3	GPMC Chip Select 3 (active low)	O	G3
gpmc_cs4	GPMC Chip Select 4 (active low)	O	H2
gpmc_cs5	GPMC Chip Select 5 (active low)	O	H6
gpmc_cs6	GPMC Chip Select 6 (active low)	O	H5

**Table 4-7. GPMC Signal Descriptions (continued)**

SIGNAL NAME	DESCRIPTION	TYPE	BALL
gpmc_cs7	GPMC Chip Select 7 (active low)	O	L4
gpmc_clk <sup>(1)(2)</sup>	GPMC Clock output	IO	L4
gpmc_advn_ale	GPMC address valid active low or address latch enable	O	H5
gpmc_oen_ren	GPMC output enable active low or read enable	O	G5
gpmc_wen	GPMC write enable active low	O	G6
gpmc_ben0	GPMC lower-byte enable active low	O	H2
gpmc_ben1	GPMC upper-byte enable active low	O	H6
gpmc_wait0	GPMC external indication of wait 0	I	F6
gpmc_wait1	GPMC external indication of wait 1	I	H5, L4

- (1) This clock signal is implemented as 'pad loopback' inside the device - the output signal is looped back through the input buffer to serve as the internal reference signal. Series termination is recommended (as close to device pin as possible) to improve signal integrity of the clock input. Any nonmonotonicity in voltage that occurs at the pad loopback clock pin between  $V_{IH}$  and  $V_{IL}$  must be less than  $V_{HYS}$ .
- (2) The gpio6\_16.clkout1 signal can be used as an "always-on" alternative to gpmc\_clk provided that the external device can support the associated timing. See [Table 5-47 GPMC/NOR Flash Interface Switching Characteristics - Synchronous Mode - Default](#) and [Table 5-49 GPMC/NOR Flash Interface Switching Characteristics - Synchronous Mode - Alternate](#) for timing information.
- (3) The internal pull resistors for balls A4, E7, D6, C5, D7, C6, A5, B6 are permanently disabled when sysboot15 is set to 0 as described in the section Sysboot Configuration of the Device TRM. If internal pull-up/down resistors are desired on these balls then sysboot15 should be set to 1. If gpmc boot mode is used with SYSBOOT15=0 (not recommended) then external pull-downs should be implemented to keep the address bus at logic-1 value during boot since the gpmc ms-address bits are high-z during boot.

### 4.3.7 Timers

---

#### NOTE

For more information, see the Timers section of the device TRM.

---

**Table 4-8. Timers Signal Descriptions**

SIGNAL NAME	DESCRIPTION	TYPE	BALL
timer1	PWM output/event trigger input	IO	H21, H6
timer2	PWM output/event trigger input	IO	H2, K22
timer3	PWM output/event trigger input	IO	H5, K23
timer4	PWM output/event trigger input	IO	A16, L4
timer5	PWM output/event trigger input	IO	A18, K6
timer6	PWM output/event trigger input	IO	B17, H4
timer7	PWM output/event trigger input	IO	B16, H3
timer8	PWM output/event trigger input	IO	B18, G1
timer9	PWM output/event trigger input	IO	A19, L3
timer10	PWM output/event trigger input	IO	E17, J2
timer11	PWM output/event trigger input	IO	E16, H1
timer12	PWM output/event trigger input	IO	F16, K4
timer13	PWM output/event trigger input	IO	J25
timer14	PWM output/event trigger input	IO	J24
timer15	PWM output/event trigger input	IO	AA6, H24
timer16	PWM output/event trigger input	IO	AD3, H25

### 4.3.8 I<sup>2</sup>C

---

**NOTE**

For more information, see the Serial Communication Interface / Multimaster High-Speed I2C Controller / HS I2C Environment / HS I2C in I2C Mode section of the device TRM.

---

**NOTE**

I<sup>2</sup>C1 and I<sup>2</sup>C2 do NOT support HS-mode.

---

**Table 4-9. I<sup>2</sup>C Signal Descriptions**

SIGNAL NAME	DESCRIPTION	TYPE	BALL
<b>Inter-Integrated Circuit Interface 1 (I2C1)</b>			
i2c1_scl	I2C1 Clock	IOD	G22
i2c1_sda	I2C1 Data	IOD	G23
<b>Inter-Integrated Circuit Interface 2 (I2C2)</b>			
i2c2_scl	I2C2 Clock	IOD	G21
i2c2_sda	I2C2 Data	IOD	F23
<b>Inter-Integrated Circuit Interface 3 (I2C3)</b>			
i2c3_scl	I2C3 Clock	IOD	C17, K22, L4, Y6
i2c3_sda	I2C3 Data	IOD	C16, H21, H5, Y5
<b>Inter-Integrated Circuit Interface 4 (I2C4)</b>			
i2c4_scl	I2C4 Clock	IOD	B25, D17, M1, V5
i2c4_sda	I2C4 Data	IOD	C23, D16, M2, U5
<b>Inter-Integrated Circuit Interface 5 (I2C5)</b>			
i2c5_scl	I2C5 Clock	IOD	B14, K3, U6
i2c5_sda	I2C5 Data	IOD	AC3, D14, K2
<b>Inter-Integrated Circuit Interface 6 (I2C6)</b>			
i2c6_scl	I2C6 Clock	IOD	A24
i2c6_sda	I2C6 Data	IOD	D23

### 4.3.9 UART

---

**NOTE**

For more information about UART booting, see the Initialization / Device Initialization by ROM Code / Peripheral Booting / Initialization Phase for UART Boot section of the device TRM.

---

**Table 4-10. UART Signal Descriptions**

SIGNAL NAME	DESCRIPTION	TYPE	BALL
<b>Universal Asynchronous Receiver/Transmitter 1 (UART1)</b>			
uart1_dcdn	UART1 Data Carrier Detect active low	I	N23
uart1_dsrn	UART1 Data Set Ready Active Low	I	N25
uart1_dtrn	UART1 Data Terminal Ready Active Low	O	N22
uart1_rin	UART1 Ring Indicator	I	N24
uart1_rxd	UART1 Receive Data	I	L25
uart1_txd	UART1 Transmit Data	O	M25
uart1_ctsn	UART1 clear to send active low	I	L20
uart1_rtsn	UART1 request to send active low	O	M24

**Table 4-10. UART Signal Descriptions (continued)**

SIGNAL NAME	DESCRIPTION	TYPE	BALL
<b>Universal Asynchronous Receiver/Transmitter 2 (UART2)</b>			
uart2_rxd	UART2 Receive Data	I	N23
uart2_txd	UART2 Transmit Data	O	N25
uart2_ctsn	UART2 clear to send active low	I	N22
uart2_rtsn	UART2 request to send active low	O	N24
<b>Universal Asynchronous Receiver/Transmitter 3 (UART3)/IrDA</b>			
uart3_rxd	UART3 Receive Data	I	AA5, G25, N22, N5
uart3_txd	UART3 Transmit Data	O	AC4, F25, N24, N6
uart3_ctsn	UART3 clear to send active low	I	G24, L6, N23, T4
uart3_rtsn	UART3 request to send active low	O	F24, L5, N25, T5
uart3_rctx	Remote control data	O	N23
uart3_sd	Infrared transceiver configure/shutdown	O	N25
uart3_irtx	Infrared data output	O	N24
<b>Universal Asynchronous Receiver/Transmitter 4 (UART4)</b>			
uart4_rxd	UART4 Receive Data	I	A24, E24, P4
uart4_txd	UART4 Transmit Data	O	D23, E25, P3
uart4_ctsn	UART4 clear to send active low	I	R2
uart4_rtsn	UART4 request to send active low	O	R1
<b>Universal Asynchronous Receiver/Transmitter 5 (UART5)</b>			
uart5_rxd	UART5 Receive Data	I	B22, G24, M1, Y4
uart5_txd	UART5 Transmit Data	O	AA2, B23, F24, M2
uart5_ctsn	UART5 clear to send active low	I	AA3, L2
uart5_rtsn	UART5 request to send active low	O	L1, W2
<b>Universal Asynchronous Receiver/Transmitter 6 (UART6)</b>			
uart6_rxd	UART6 Receive Data	I	D14, K3, U5
uart6_txd	UART6 Transmit Data	O	B14, K2, V5
uart6_ctsn	UART6 clear to send active low	I	C14, J1
uart6_rtsn	UART6 request to send active low	O	B15, K1
<b>Universal Asynchronous Receiver/Transmitter 7 (UART7)</b>			
uart7_rxd	UART7 Receive Data	I	A22, L2
uart7_txd	UART7 Transmit Data	O	A23, L1
uart7_ctsn	UART7 clear to send active low	I	B22
uart7_rtsn	UART7 request to send active low	O	B23
<b>Universal Asynchronous Receiver/Transmitter 8 (UART8)</b>			
uart8_rxd	UART8 Receive Data	I	C23, H22, J1
uart8_txd	UART8 Transmit Data	O	B25, H23, K1
uart8_ctsn	UART8 clear to send active low	I	A24
uart8_rtsn	UART8 request to send active low	O	D23
<b>Universal Asynchronous Receiver/Transmitter 9 (UART9)</b>			
uart9_rxd	UART9 Receive Data	I	AC3, E8, L20
uart9_txd	UART9 Transmit Data	O	B8, M24, U6
uart9_ctsn	UART9 clear to send active low	I	AA5, C8
uart9_rtsn	UART9 request to send active low	O	AC4, B9
<b>Universal Asynchronous Receiver/Transmitter 10 (UART10)</b>			
uart10_rxd	UART10 Receive Data	I	A7, H21, N22, Y3
uart10_txd	UART10 Transmit Data	O	A9, AA1, K22, N24
uart10_ctsn	UART10 clear to send active low	I	A8, AA4

**Table 4-10. UART Signal Descriptions (continued)**

SIGNAL NAME	DESCRIPTION	TYPE	BALL
uart10_rtsn	UART10 request to send active low	O	A11, AB1

### 4.3.10 McSPI

**NOTE**

For more information, see the Serial Communication Interface / Multichannel Serial Peripheral Interface (McSPI) section of the device TRM.

**Table 4-11. SPI Signal Descriptions**

SIGNAL NAME	DESCRIPTION	TYPE	BALL
<b>Serial Peripheral Interface 1</b>			
spi1_sclk <sup>(1)</sup>	SPI1 Clock	IO	C24
spi1_d1	SPI1 Data. Can be configured as either MISO or MOSI.	IO	D24
spi1_d0	SPI1 Data. Can be configured as either MISO or MOSI.	IO	D25
spi1_cs0	SPI1 Chip Select	IO	B24
spi1_cs1	SPI1 Chip Select	IO	C25
spi1_cs2	SPI1 Chip Select	IO	E24
spi1_cs3	SPI1 Chip Select	IO	E25
<b>Serial Peripheral Interface 2</b>			
spi2_sclk <sup>(1)</sup>	SPI2 Clock	IO	G25
spi2_d1	SPI2 Data. Can be configured as either MISO or MOSI.	IO	F25
spi2_d0	SPI2 Data. Can be configured as either MISO or MOSI.	IO	G24
spi2_cs0	SPI2 Chip Select	IO	F24
spi2_cs1	SPI2 Chip Select	IO	C25
spi2_cs2	SPI2 Chip Select	IO	E24
spi2_cs3	SPI2 Chip Select	IO	E25
<b>Serial Peripheral Interface 3</b>			
spi3_sclk <sup>(1)</sup>	SPI3 Clock	IO	A18, C23, N5, Y1
spi3_d1	SPI3 Data. Can be configured as either MISO or MOSI.	IO	B17, B25, N6, Y4
spi3_d0	SPI3 Data. Can be configured as either MISO or MOSI.	IO	A24, AA2, B16, T4
spi3_cs0	SPI3 Chip Select	IO	AA3, B18, D23, T5
spi3_cs1	SPI3 Chip Select	IO	A19, W2
<b>Serial Peripheral Interface 4</b>			
spi4_sclk <sup>(1)</sup>	SPI4 Clock	IO	AC3, E8, K4, P4, Y3
spi4_d1	SPI4 Data. Can be configured as either MISO or MOSI.	IO	AA1, B8, H1, P3, U6
spi4_d0	SPI4 Data. Can be configured as either MISO or MOSI.	IO	AA4, AA5, C8, J2, R2
spi4_cs0	SPI4 Chip Select	IO	AB1, AC4, B9, L3, R1
spi4_cs1	SPI4 Chip Select	IO	G1, N6
spi4_cs2	SPI4 Chip Select	IO	H3, T4
spi4_cs3	SPI4 Chip Select	IO	H4, T5

- (1) This clock signal is implemented as 'pad loopback' inside the device - the output signal is looped back through the input buffer to serve as the internal reference signal. Series termination is recommended (as close to device pin as possible) to improve signal integrity of the clock input. Any nonmonotonicity in voltage that occurs at the pad loopback clock pin between  $V_{IH}$  and  $V_{IL}$  must be less than  $V_{HYS}$ .

### 4.3.11 QSPI

#### NOTE

For more information about UART booting, see the Initialization / Device Initialization by ROM Code / Memory Booting / SPI/QSPI Flash Devices section of the device TRM.

**Table 4-12. QSPI Signal Descriptions**

SIGNAL NAME	DESCRIPTION	TYPE	BALL
qspi1_sclk	QSPI1 Serial Clock	IO	F2
qspi1_rtclk	QSPI1 Return Clock Input. Must be connected from QSPI1_SCLK on PCB. Refer to PCB Guidelines for QSPI1	I	H3
qspi1_d0	QSPI1 Data[0]. This pin is output data for all commands/writes and for dual read and quad read modes it becomes input data pin during read phase.	IO	K5
qspi1_d1	QSPI1 Data[1]. Input read data in all modes.	IO	G2
qspi1_d2	QSPI1 Data[2]. This pin is used only in quad read mode as input data pin during read phase	IO	K6
qspi1_d3	QSPI1 Data[3]. This pin is used only in quad read mode as input data pin during read phase	IO	H4
qspi1_cs0	QSPI1 Chip Select[0]. This pin is Used for QSPI1 boot modes.	IO	G4
qspi1_cs1	QSPI1 Chip Select[1]	O	G3
qspi1_cs2	QSPI1 Chip Select[2]	O	L1
qspi1_cs3	QSPI1 Chip Select[3]	O	K3

### 4.3.12 McASP

#### NOTE

For more information, see the Serial Communication Interface / Multichannel Audio Serial Port (McASP) section of the device TRM.

**Table 4-13. McASP Signal Descriptions**

SIGNAL NAME	DESCRIPTION	TYPE	BALL
<b>Multichannel Audio Serial Port 1</b>			
mcasp1_axr0	McASP1 Transmit/Receive Data	IO	D14
mcasp1_axr1	McASP1 Transmit/Receive Data	IO	B14
mcasp1_axr2	McASP1 Transmit/Receive Data	IO	C14
mcasp1_axr3	McASP1 Transmit/Receive Data	IO	B15
mcasp1_axr4	McASP1 Transmit/Receive Data	IO	A15, J25
mcasp1_axr5	McASP1 Transmit/Receive Data	IO	A14, J24
mcasp1_axr6	McASP1 Transmit/Receive Data	IO	A17, H24
mcasp1_axr7	McASP1 Transmit/Receive Data	IO	A16, H25
mcasp1_axr8	McASP1 Transmit/Receive Data	IO	A18, H21
mcasp1_axr9	McASP1 Transmit/Receive Data	IO	B17, K22
mcasp1_axr10	McASP1 Transmit/Receive Data	IO	B16, K23
mcasp1_axr11	McASP1 Transmit/Receive Data	IO	B18
mcasp1_axr12	McASP1 Transmit/Receive Data	IO	A19
mcasp1_axr13	McASP1 Transmit/Receive Data	IO	E17
mcasp1_axr14	McASP1 Transmit/Receive Data	IO	E16

**Table 4-13. McASP Signal Descriptions (continued)**

SIGNAL NAME	DESCRIPTION	TYPE	BALL
mcasp1_axr15	McASP1 Transmit/Receive Data	IO	F16
mcasp1_fsx	McASP1 Transmit Frame Sync	IO	C17
mcasp1_aclkr <sup>(1)</sup>	McASP1 Receive Bit Clock	IO	D16
mcasp1_fsr	McASP1 Receive Frame Sync	IO	D17
mcasp1_ahclkx	McASP1 Transmit High-Frequency Master Clock	O	J25
mcasp1_aclkx <sup>(1)</sup>	McASP1 Transmit Bit Clock	IO	C16
<b>Multichannel Audio Serial Port 2</b>			
mcasp2_axr0	McASP2 Transmit/Receive Data	IO	A20
mcasp2_axr1	McASP2 Transmit/Receive Data	IO	B19
mcasp2_axr2	McASP2 Transmit/Receive Data	IO	A21
mcasp2_axr3	McASP2 Transmit/Receive Data	IO	B21
mcasp2_axr4	McASP2 Transmit/Receive Data	IO	B20
mcasp2_axr5	McASP2 Transmit/Receive Data	IO	C19
mcasp2_axr6	McASP2 Transmit/Receive Data	IO	D20
mcasp2_axr7	McASP2 Transmit/Receive Data	IO	C20
mcasp2_axr8	McASP2 Transmit/Receive Data	IO	J25
mcasp2_axr9	McASP2 Transmit/Receive Data	IO	J24
mcasp2_axr10	McASP2 Transmit/Receive Data	IO	H24
mcasp2_axr11	McASP2 Transmit/Receive Data	IO	H25
mcasp2_axr12	McASP2 Transmit/Receive Data	IO	A22
mcasp2_axr13	McASP2 Transmit/Receive Data	IO	A23
mcasp2_axr14	McASP2 Transmit/Receive Data	IO	B22
mcasp2_axr15	McASP2 Transmit/Receive Data	IO	B23
mcasp2_fsx	McASP2 Transmit Frame Sync	IO	D19
mcasp2_ahclkx	McASP2 Transmit High-Frequency Master Clock	O	J24
mcasp2_aclkx <sup>(1)</sup>	McASP2 Transmit Bit Clock	IO	E19
<b>Multichannel Audio Serial Port 3</b>			
mcasp3_axr0	McASP3 Transmit/Receive Data	IO	B22
mcasp3_axr1	McASP3 Transmit/Receive Data	IO	B23
mcasp3_axr2	McASP3 Transmit/Receive Data	IO	A21
mcasp3_axr3	McASP3 Transmit/Receive Data	IO	B21
mcasp3_fsx	McASP3 Transmit Frame Sync	IO	A23
mcasp3_ahclkx	McASP3 Transmit High-Frequency Master Clock	O	H24
mcasp3_aclkx <sup>(1)</sup>	McASP3 Transmit Bit Clock	IO	A22
mcasp3_aclkr <sup>(1)</sup>	McASP3 Receive Bit Clock	IO	A22
mcasp3_fsr	McASP3 Receive Frame Sync	IO	A23
<b>Multichannel Audio Serial Port 4</b>			
mcasp4_axr0	McASP4 Transmit/Receive Data	IO	A24
mcasp4_axr1	McASP4 Transmit/Receive Data	IO	D23
mcasp4_axr2	McASP4 Transmit/Receive Data	IO	A15
mcasp4_axr3	McASP4 Transmit/Receive Data	IO	A14
mcasp4_fsx	McASP4 Transmit Frame Sync	IO	B25
mcasp4_ahclkx	McASP4 Transmit High-Frequency Master Clock	O	H25
mcasp4_aclkx <sup>(1)</sup>	McASP4 Transmit Bit Clock	IO	C23
mcasp4_aclkr <sup>(1)</sup>	McASP4 Receive Bit Clock	IO	C23
mcasp4_fsr	McASP4 Receive Frame Sync	IO	B25
<b>Multichannel Audio Serial Port 5</b>			

**Table 4-13. McASP Signal Descriptions (continued)**

SIGNAL NAME	DESCRIPTION	TYPE	BALL
mcasp5_axr0	McASP5 Transmit/Receive Data	IO	AA5
mcasp5_axr1	McASP5 Transmit/Receive Data	IO	AC4
mcasp5_axr2	McASP5 Transmit/Receive Data	IO	A17
mcasp5_axr3	McASP5 Transmit/Receive Data	IO	A16
mcasp5_fsx	McASP5 Transmit Frame Sync	IO	U6
mcasp5_ahclkx	McASP5 Transmit High-Frequency Master Clock	O	J25
mcasp5_aclkx <sup>(1)</sup>	McASP5 Transmit Bit Clock	IO	AC3
mcasp5_aclkr <sup>(1)</sup>	McASP5 Receive Bit Clock	IO	AC3
mcasp5_fsr	McASP5 Receive Frame Sync	IO	U6
<b>Multichannel Audio Serial Port 6</b>			
mcasp6_axr0	McASP6 Transmit/Receive Data	IO	A18
mcasp6_axr1	McASP6 Transmit/Receive Data	IO	B17
mcasp6_axr2	McASP6 Transmit/Receive Data	IO	C14
mcasp6_axr3	McASP6 Transmit/Receive Data	IO	B15
mcasp6_ahclkx	McASP6 Transmit High-Frequency Master Clock	O	J24
mcasp6_aclkx <sup>(1)</sup>	McASP6 Transmit Bit Clock	IO	B16
mcasp6_fsx	McASP6 Transmit Frame Sync	IO	B18
mcasp6_aclkr <sup>(1)</sup>	McASP6 Receive Bit Clock	IO	B16
mcasp6_fsr	McASP6 Receive Frame Sync	IO	B18
<b>Multichannel Audio Serial Port 7</b>			
mcasp7_aclkr <sup>(1)</sup>	McASP7 Receive Bit Clock I/O	IO	E16
mcasp7_aclkx <sup>(1)</sup>	McASP7 Transmit Bit Clock I/O	IO	E16
mcasp7_ahclkx	McASP7 Transmit High-Frequency Master Clock	O	H24
mcasp7_axr0	McASP7 Transmit/Receive Data I/O	IO	A19
mcasp7_axr1	McASP7 Transmit/Receive Data I/O	IO	E17
mcasp7_axr2	McASP7 Transmit/Receive Data I/O	IO	D16
mcasp7_axr3	McASP7 Transmit/Receive Data I/O	IO	D17
mcasp7_fsr	McASP7 Receive Frame Sync I/O	IO	F16
mcasp7_fsx	McASP7 Transmit Frame Sync I/O	IO	F16
<b>Multichannel Audio Serial Port 8</b>			
mcasp8_aclkr <sup>(1)</sup>	McASP8 Receive Bit Clock I/O	IO	D20
mcasp8_aclkx <sup>(1)</sup>	McASP8 Transmit Bit Clock I/O	IO	D20
mcasp8_ahclkx	McASP8 Transmit High-Frequency Master Clock I/O	O	H25
mcasp8_axr0	McASP8 Transmit/Receive Data I/O	IO	B20
mcasp8_axr1	McASP8 Transmit/Receive Data I/O	IO	C19
mcasp8_fsr	McASP8 Receive Frame Sync I/O	IO	C20
mcasp8_fsx	McASP8 Transmit Frame Sync I/O	IO	C20

(1) This clock signal is implemented as 'pad loopback' inside the device - the output signal is looped back through the input buffer to serve as the internal reference signal. Series termination is recommended (as close to device pin as possible) to improve signal integrity of the clock input. Any non monotonicity in voltage that occurs at the pad loopback clock pin between  $V_{IH}$  and  $V_{IL}$  must be less than  $V_{HYS}$ .

### 4.3.13 USB

#### NOTE

For more information, see: Serial Communication Interface / SuperSpeed USB DRD Subsystem section of the device TRM.



**Table 4-14. Universal Serial Bus Signal Descriptions**

SIGNAL NAME	DESCRIPTION	TYPE	BALL
<b>Universal Serial Bus 1</b>			
usb1_dm	USB1 USB2.0 differential signal pair (negative)	IODS	AB7
usb1_dp	USB1 USB2.0 differential signal pair (positive)	IODS	AC6
usb1_drvvbus	USB1 Drive VBUS signal	O	AD3
usb_rxn0 <sup>(1)</sup>	USB1 USB3.0 receiver negative lane	IDS	AE5
usb_rxp0 <sup>(1)</sup>	USB1 USB3.0 receiver positive lane	IDS	AD6
usb_txn0 <sup>(1)</sup>	USB1 USB3.0 transmitter negative lane	ODS	AE3
usb_txp0 <sup>(1)</sup>	USB1 USB3.0 transmitter positive lane	ODS	AD4
<b>Universal Serial Bus 2</b>			
usb2_dm	USB2 USB2.0 differential signal pair (negative)	IO	AC5
usb2_dp	USB2 USB2.0 differential signal pair (positive)	IO	AB6
usb2_drvvbus	USB2 Drive VBUS signal	O	AA6
<b>Universal Serial Bus 3</b>			
usb3_ulpi_d0	USB3 - ULPI 8-bit data bus	IODS	R2, W2
usb3_ulpi_d1	USB3 - ULPI 8-bit data bus	IODS	AA3, R1
usb3_ulpi_d2	USB3 - ULPI 8-bit data bus	IO	AA2, N2
usb3_ulpi_d3	USB3 - ULPI 8-bit data bus	IO	P2, Y4
usb3_ulpi_d4	USB3 - ULPI 8-bit data bus	IO	N1, Y1
usb3_ulpi_d5	USB3 - ULPI 8-bit data bus	IO	P1, Y2
usb3_ulpi_d6	USB3 - ULPI 8-bit data bus	IO	N3, Y6
usb3_ulpi_d7	USB3 - ULPI 8-bit data bus	IO	N4, Y5
usb3_ulpi_nxt	USB3 - ULPI next	I	P3, Y3
usb3_ulpi_dir	USB3 - ULPI bus direction	I	AA1, P4
usb3_ulpi_stp	USB3 - ULPI stop	O	AA4, T5
usb3_ulpi_clk	USB3 - ULPI functional clock	I	AB1, T4

(1) Signals are enabled by selecting the correct field in the PCIE\_B1C0\_MODE\_SEL register. There are no CTRL\_CORE\_PAD\* register involved.

#### 4.3.14 PCIe

#### NOTE

For more information, see the *Serial Communication Interfaces / PCIe Controllers* and the *Shared PHY Component Subsystems / PCIe Shared PHY Subsystem* sections of the device TRM.

**Table 4-15. PCIe Signal Descriptions**

SIGNAL NAME	DESCRIPTION	TYPE	BALL
pcie_rxn0	PCIe1_PHY_RX Receive Data Lane 0 (negative) - mapped to PCIe_SS1 only.	IDS	AE6
pcie_rxp0	PCIe1_PHY_RX Receive Data Lane 0 (positive) - mapped to PCIe_SS1 only.	IDS	AD7
pcie_txn0	PCIe1_PHY_TX Transmit Data Lane 0 (negative) - mapped to PCIe_SS1 only.	ODS	AE8
pcie_txp0	PCIe1_PHY_TX Transmit Data Lane 0 (positive) - mapped to PCIe_SS1 only.	ODS	AD9
pcie_rxn1	PCIe2_PHY_RX Receive Data Lane 1 (negative) - mapped to either PCIe_SS1 (dual lane- mode) or PCIe_SS2 (single lane- mode)	IDS	AE5
pcie_rxp1	PCIe2_PHY_RX Receive Data Lane 1 (positive) - mapped to either PCIe_SS1 (dual lane- mode) or PCIe_SS2 (single lane- mode)	IDS	AD6
pcie_txn1	PCIe2_PHY_TX Transmit Data Lane 1 (negative) - mapped to either PCIe_SS1 (dual lane- mode) or PCIe_SS2 (single lane- mode)	ODS	AE3
pcie_txp1	PCIe2_PHY_TX Transmit Data Lane 1 (positive) - mapped to either PCIe_SS1 (dual lane- mode) or PCIe_SS2 (single lane- mode)	ODS	AD4

**Table 4-15. PCIe Signal Descriptions (continued)**

SIGNAL NAME	DESCRIPTION	TYPE	BALL
ljcb_clkn	PCIe1_PHY / PCIe2_PHY shared Reference Clock Input / Output Differential Pair (negative)	IODS	AB9
ljcb_clkp	PCIe1_PHY / PCIe2_PHY shared Reference Clock Input / Output Differential Pair (positive)	IODS	AC8

**4.3.15 DCAN****NOTE**

For more information, see the Serial Communication Interface / DCAN section of the device TRM.

**Table 4-16. DCAN Signal Descriptions**

SIGNAL NAME	DESCRIPTION	TYPE	BALL
<b>DCAN 1</b>			
dcan1_rx	DCAN1 receive data pin	IO	H23, AC10
dcan1_tx	DCAN1 transmit data pin	IO	H22
<b>DCAN 2</b>			
dcan2_rx	DCAN2 receive data pin	IO	E25, K22, AB10
dcan2_tx	DCAN2 transmit data pin	IO	E24, H21

**4.3.16 GMAC\_SW****NOTE**

For more information, see the Serial Communication Interfaces / Ethernet Controller section of the device TRM.

**Table 4-17. GMAC Signal Descriptions**

SIGNAL NAME	DESCRIPTION	TYPE	BALL
rgmii0_rxc	RGMIIO Receive Clock	I	N2
rgmii0_rxctl	RGMIIO Receive Control	I	P2
rgmii0_rxd0	RGMIIO Receive Data	I	N4
rgmii0_rxd1	RGMIIO Receive Data	I	N3
rgmii0_rxd2	RGMIIO Receive Data	I	P1
rgmii0_rxd3	RGMIIO Receive Data	I	N1
rgmii0_txc	RGMIIO Transmit Clock	O	T4
rgmii0_txctl	RGMIIO Transmit Enable	O	T5
rgmii0_txd0	RGMIIO Transmit Data	O	R1
rgmii0_txd1	RGMIIO Transmit Data	O	R2
rgmii0_txd2	RGMIIO Transmit Data	O	P3
rgmii0_txd3	RGMIIO Transmit Data	O	P4
rgmii1_rxc	RGMIIO1 Receive Clock	I	E11
rgmii1_rxctl	RGMIIO1 Receive Control	I	F11
rgmii1_rxd0	RGMIIO1 Receive Data	I	D13
rgmii1_rxd1	RGMIIO1 Receive Data	I	C13
rgmii1_rxd2	RGMIIO1 Receive Data	I	E13
rgmii1_rxd3	RGMIIO1 Receive Data	I	B13
rgmii1_txc	RGMIIO1 Transmit Clock	O	B11

**Table 4-17. GMAC Signal Descriptions (continued)**

SIGNAL NAME	DESCRIPTION	TYPE	BALL
rgmii1_txctl	RGMI1 Transmit Enable	O	D11
rgmii1_txd0	RGMI1 Transmit Data	O	A13
rgmii1_txd1	RGMI1 Transmit Data	O	A12
rgmii1_txd2	RGMI1 Transmit Data	O	B12
rgmii1_txd3	RGMI1 Transmit Data	O	C11
mii1_col	MII1 Collision Detect (Sense) input	I	E13
mii1_crs	MII1 Carrier Sense input	I	C13
mii1_rxclk	MII1 Receive Clock	I	B11
mii1_rxd0	MII1 Receive Data	I	E10
mii1_rxd1	MII1 Receive Data	I	F10
mii1_rxd2	MII1 Receive Data	I	A10
mii1_rxd3	MII1 Receive Data	I	B10
mii1_rxdv	MII1 Receive Data Valid input	I	D11
mii1_rxer	MII1 Receive Data Error input	I	B13
mii1_txclk	MII1 Transmit Clock	I	C11
mii1_txd0	MII1 Transmit Data	O	B12
mii1_txd1	MII1 Transmit Data	O	A12
mii1_txd2	MII1 Transmit Data	O	A13
mii1_txd3	MII1 Transmit Data	O	E11
mii1_txen	MII1 Transmit Data Enable Output	O	D13
mii1_txer	MII1 Transmit Error	O	F11
mii0_col	MII0 Collision Detect (Sense) input	I	L5
mii0_crs	MII0 Carrier Sense input	I	P4
mii0_rxclk	MII0 Receive Clock	I	N6
mii0_rxd0	MII0 Receive Data	I	R1
mii0_rxd1	MII0 Receive Data	I	R2
mii0_rxd2	MII0 Receive Data	I	T5
mii0_rxd3	MII0 Receive Data	I	T4
mii0_rxdv	MII0 Receive Data Valid input	I	N5
mii0_rxer	MII0 Receive Data Error input	I	P3
mii0_txclk	MII0 Transmit Clock	I	N2
mii0_txd0	MII0 Transmit Data	O	N4
mii0_txd1	MII0 Transmit Data	O	N3
mii0_txd2	MII0 Transmit Data	O	N1
mii0_txd3	MII0 Transmit Data	O	P2
mii0_txen	MII0 Transmit Data Enable Output	O	P1
mii0_txer	MII0 Transmit Error	O	L6
rmii1_crs	RMII1 Carrier Sense input	I	N5
rmii1_rxd0	RMII1 Receive Data	I	T5
rmii1_rxd1	RMII1 Receive Data	I	T4
rmii1_rxer	RMII1 Receive Data Error input	I	N6
rmii1_txd0	RMII1 Transmit Data	O	N1
rmii1_txd1	RMII1 Transmit Data	O	P2
rmii1_txen	RMII1 Transmit Data Enable output	O	N2
rmii0_crs	RMII0 Carrier Sense input	I	P4
rmii0_rxd0	RMII0 Receive Data	I	R1
rmii0_rxd1	RMII0 Receive Data	I	R2

**Table 4-17. GMAC Signal Descriptions (continued)**

SIGNAL NAME	DESCRIPTION	TYPE	BALL
rmii0_rxer	RMII0 Receive Data Error input	I	P3
rmii0_txd0	RMII0 Transmit Data	O	N4
rmii0_txd1	RMII0 Transmit Data	O	N3
rmii0_txen	RMII0 Transmit Data Enable output	O	P1
mdio_mclk	Management Data Serial Clock	O	D10, E24, L5, Y5
mdio_d	Management Data	IO	C10, E25, L6, Y6

**4.3.17 eMMC/SD/SDIO****NOTE**

For more information, see the HS MMC/SDIO section of the device TRM.

**Table 4-18. eMMC/SD/SDIO Signal Descriptions**

SIGNAL NAME	DESCRIPTION	TYPE	BALL
<b>Multi Media Card 1</b>			
mmc1_clk <sup>(1)</sup>	MMC1 clock	IO	U3
mmc1_cmd	MMC1 command	IO	V4
mmc1_dat0	MMC1 data bit 0	IO	V3
mmc1_dat1	MMC1 data bit 1	IO	V2
mmc1_dat2	MMC1 data bit 2	IO	W1
mmc1_dat3	MMC1 data bit 3	IO	V1
mmc1_sdcd	MMC1 Card Detect	I	U5
mmc1_sdwp	MMC1 Write Protect	I	V5
<b>Multi Media Card 2</b>			
mmc2_clk <sup>(1)</sup>	MMC2 clock	IO	B5
mmc2_cmd	MMC2 command	IO	A6
mmc2_dat0	MMC2 data bit 0	IO	D7
mmc2_dat1	MMC2 data bit 1	IO	C6
mmc2_dat2	MMC2 data bit 2	IO	A5
mmc2_dat3	MMC2 data bit 3	IO	B6
mmc2_dat4	MMC2 data bit 4	IO	A4
mmc2_dat5	MMC2 data bit 5	IO	E7
mmc2_dat6	MMC2 data bit 6	IO	D6
mmc2_dat7	MMC2 data bit 7	IO	C5
mmc2_sdcd	MMC2 Card Detect	I	H22
mmc2_sdwp	MMC2 Write Protect	I	H23
<b>Multi Media Card 3</b>			
mmc3_clk <sup>(1)</sup>	MMC3 clock	IO	Y2
mmc3_cmd	MMC3 command	IO	Y1
mmc3_dat0	MMC3 data bit 0	IO	Y4
mmc3_dat1	MMC3 data bit 1	IO	AA2
mmc3_dat2	MMC3 data bit 2	IO	AA3
mmc3_dat3	MMC3 data bit 3	IO	W2
mmc3_dat4	MMC3 data bit 4	IO	Y3
mmc3_dat5	MMC3 data bit 5	IO	AA1
mmc3_dat6	MMC3 data bit 6	IO	AA4

**Table 4-18. eMMC/SD/SDIO Signal Descriptions (continued)**

SIGNAL NAME	DESCRIPTION	TYPE	BALL
mmc3_dat7	MMC3 data bit 7	IO	AB1
mmc3_sdcd	MMC3 Card Detect	I	E24
mmc3_sdwp	MMC3 Write Protect	I	E25
<b>Multi Media Card 4</b>			
mmc4_clk <sup>(1)</sup>	MMC4 clock	IO	L20
mmc4_cmd	MMC4 command	IO	M24
mmc4_sdcd	MMC4 Card Detect	I	L25
mmc4_sdwp	MMC4 Write Protect	I	M25
mmc4_dat0	MMC4 data bit 0	IO	N23
mmc4_dat1	MMC4 data bit 1	IO	N25
mmc4_dat2	MMC4 data bit 2	IO	N22
mmc4_dat3	MMC4 data bit 3	IO	N24

(1) By default, this clock signal is implemented as 'pad loopback' inside the device - the output signal is looped back through the input buffer to serve as the internal reference signal. mmc1\_clk and mmc2\_clk have an optional software programmable setting to use an 'internal loopback clock' instead of the default 'pad loopback clock'. If the 'pad loopback clock' is used, series termination is recommended (as close to device pin as possible) to improve signal integrity of the clock input. Any nonmonotonicity in voltage that occurs at the pad loopback clock pin between  $V_{IH}$  and  $V_{IL}$  must be less than  $V_{HYS}$ .

### 4.3.18 GPIO

#### NOTE

For more information, see the General-Purpose Interface section of the device TRM.

**Table 4-19. GPIOs Signal Descriptions**

SIGNAL NAME	DESCRIPTION	TYPE	BALL
<b>GPIO 1</b>			
gpio1_0	General-Purpose Input	I	AC10
gpio1_3	General-Purpose Input	I	AB10
gpio1_4	General-Purpose Input/Output	IO	B20
gpio1_5	General-Purpose Input/Output	IO	C20
gpio1_6	General-Purpose Input/Output	IO	F1
gpio1_7	General-Purpose Input/Output	IO	E2
gpio1_8	General-Purpose Input/Output	IO	E1
gpio1_9	General-Purpose Input/Output	IO	C1
gpio1_10	General-Purpose Input/Output	IO	D1
gpio1_11	General-Purpose Input/Output	IO	D2
gpio1_12	General-Purpose Input/Output	IO	B1
gpio1_13	General-Purpose Input/Output	IO	B2
gpio1_14	General-Purpose Input/Output	IO	H22
gpio1_15	General-Purpose Input/Output	IO	H23
gpio1_16	General-Purpose Input/Output	IO	N22
gpio1_17	General-Purpose Input/Output	IO	N24
gpio1_18	General-Purpose Input/Output	IO	C3
gpio1_19	General-Purpose Input/Output	IO	C4
gpio1_20	General-Purpose Input/Output	IO	A3
gpio1_21	General-Purpose Input/Output	IO	B4
gpio1_22	General-Purpose Input/Output	IO	Y3
gpio1_23	General-Purpose Input/Output	IO	AA1

**Table 4-19. GPIOs Signal Descriptions (continued)**

SIGNAL NAME	DESCRIPTION	TYPE	BALL
gpio1_24	General-Purpose Input/Output	IO	AA4
gpio1_25	General-Purpose Input/Output	IO	AB1
gpio1_26	General-Purpose Input/Output	IO	K3
gpio1_27	General-Purpose Input/Output	IO	K2
gpio1_28	General-Purpose Input/Output	IO	J1
gpio1_29	General-Purpose Input/Output	IO	K1
gpio1_30	General-Purpose Input/Output	IO	K4
gpio1_31	General-Purpose Input/Output	IO	H1
<b>GPIO2</b>			
gpio2_0	General-Purpose Input/Output	IO	J2
gpio2_1	General-Purpose Input/Output	IO	L3
gpio2_2	General-Purpose Input/Output	IO	G1
gpio2_3	General-Purpose Input/Output	IO	H3
gpio2_4	General-Purpose Input/Output	IO	H4
gpio2_5	General-Purpose Input/Output	IO	K6
gpio2_6	General-Purpose Input/Output	IO	K5
gpio2_7	General-Purpose Input/Output	IO	G2
gpio2_8	General-Purpose Input/Output	IO	F2
gpio2_9	General-Purpose Input/Output	IO	A4
gpio2_10	General-Purpose Input/Output	IO	E7
gpio2_11	General-Purpose Input/Output	IO	D6
gpio2_12	General-Purpose Input/Output	IO	C5
gpio2_13	General-Purpose Input/Output	IO	B5
gpio2_14	General-Purpose Input/Output	IO	D7
gpio2_15	General-Purpose Input/Output	IO	C6
gpio2_16	General-Purpose Input/Output	IO	A5
gpio2_17	General-Purpose Input/Output	IO	B6
gpio2_18	General-Purpose Input/Output	IO	A6
gpio2_19	General-Purpose Input/Output	IO	F3
gpio2_20	General-Purpose Input/Output	IO	G4
gpio2_21	General-Purpose Input/Output	IO	G3
gpio2_22	General-Purpose Input/Output	IO	L4
gpio2_23	General-Purpose Input/Output	IO	H5
gpio2_24	General-Purpose Input/Output	IO	G5
gpio2_25	General-Purpose Input/Output	IO	G6
gpio2_26	General-Purpose Input/Output	IO	H2
gpio2_27	General-Purpose Input/Output	IO	H6
gpio2_28	General-Purpose Input/Output	IO	F6
gpio2_29	General-Purpose Input/Output	IO	D20
<b>GPIO 3</b>			
gpio3_28	General-Purpose Input/Output	IO	D8
gpio3_29	General-Purpose Input/Output	IO	B7
gpio3_30	General-Purpose Input/Output	IO	C7
gpio3_31	General-Purpose Input/Output	IO	E8
<b>GPIO 4</b>			
gpio4_0	General-Purpose Input/Output	IO	B8
gpio4_1	General-Purpose Input/Output	IO	C8

**Table 4-19. GPIOs Signal Descriptions (continued)**

SIGNAL NAME	DESCRIPTION	TYPE	BALL
gpio4_2	General-Purpose Input/Output	IO	B9
gpio4_3	General-Purpose Input/Output	IO	A7
gpio4_4	General-Purpose Input/Output	IO	A9
gpio4_5	General-Purpose Input/Output	IO	A8
gpio4_6	General-Purpose Input/Output	IO	A11
gpio4_7	General-Purpose Input/Output	IO	F10
gpio4_8	General-Purpose Input/Output	IO	A10
gpio4_9	General-Purpose Input/Output	IO	B10
gpio4_10	General-Purpose Input/Output	IO	E10
gpio4_11	General-Purpose Input/Output	IO	D10
gpio4_12	General-Purpose Input/Output	IO	C10
gpio4_13	General-Purpose Input/Output	IO	B11
gpio4_14	General-Purpose Input/Output	IO	D11
gpio4_15	General-Purpose Input/Output	IO	C11
gpio4_16	General-Purpose Input/Output	IO	B12
gpio4_17	General-Purpose Input/Output	IO	B18
gpio4_18	General-Purpose Input/Output	IO	A19
gpio4_24	General-Purpose Input/Output	IO	A12
gpio4_25	General-Purpose Input/Output	IO	A13
gpio4_26	General-Purpose Input/Output	IO	E11
gpio4_27	General-Purpose Input/Output	IO	F11
gpio4_28	General-Purpose Input/Output	IO	B13
gpio4_29	General-Purpose Input/Output	IO	E13
gpio4_30	General-Purpose Input/Output	IO	C13
gpio4_31	General-Purpose Input/Output	IO	D13
<b>GPIO 5</b>			
gpio5_0	General-Purpose Input/Output	IO	D16
gpio5_1	General-Purpose Input/Output	IO	D17
gpio5_2	General-Purpose Input/Output	IO	D14
gpio5_3	General-Purpose Input/Output	IO	B14
gpio5_4	General-Purpose Input/Output	IO	C14
gpio5_5	General-Purpose Input/Output	IO	B15
gpio5_6	General-Purpose Input/Output	IO	A15
gpio5_7	General-Purpose Input/Output	IO	A14
gpio5_8	General-Purpose Input/Output	IO	A17
gpio5_9	General-Purpose Input/Output	IO	A16
gpio5_10	General-Purpose Input/Output	IO	A18
gpio5_11	General-Purpose Input/Output	IO	B17
gpio5_12	General-Purpose Input/Output	IO	B16
gpio5_13	General-Purpose Input/Output	IO	A22
gpio5_14	General-Purpose Input/Output	IO	A23
gpio5_15	General-Purpose Input/Output	IO	L5
gpio5_16	General-Purpose Input/Output	IO	L6
gpio5_17	General-Purpose Input/Output	IO	P5
gpio5_18	General-Purpose Input/Output	IO	N5
gpio5_19	General-Purpose Input/Output	IO	N6
gpio5_20	General-Purpose Input/Output	IO	T4

**Table 4-19. GPIOs Signal Descriptions (continued)**

SIGNAL NAME	DESCRIPTION	TYPE	BALL
gpio5_21	General-Purpose Input/Output	IO	T5
gpio5_22	General-Purpose Input/Output	IO	P4
gpio5_23	General-Purpose Input/Output	IO	P3
gpio5_24	General-Purpose Input/Output	IO	R2
gpio5_25	General-Purpose Input/Output	IO	R1
gpio5_26	General-Purpose Input/Output	IO	N2
gpio5_27	General-Purpose Input/Output	IO	P2
gpio5_28	General-Purpose Input/Output	IO	N1
gpio5_29	General-Purpose Input/Output	IO	P1
gpio5_30	General-Purpose Input/Output	IO	N3
gpio5_31	General-Purpose Input/Output	IO	N4
<b>GPIO 6</b>			
gpio6_4	General-Purpose Input/Output	IO	E17
gpio6_5	General-Purpose Input/Output	IO	E16
gpio6_6	General-Purpose Input/Output	IO	F16
gpio6_7	General-Purpose Input/Output	IO	C19
gpio6_8	General-Purpose Input/Output	IO	A21
gpio6_9	General-Purpose Input/Output	IO	B21
gpio6_10	General-Purpose Input/Output	IO	Y5
gpio6_11	General-Purpose Input/Output	IO	Y6
gpio6_12	General-Purpose Input/Output	IO	AD3
gpio6_13	General-Purpose Input/Output	IO	AA6
gpio6_14	General-Purpose Input/Output	IO	H21
gpio6_15	General-Purpose Input/Output	IO	K22
gpio6_16	General-Purpose Input/Output	IO	K23
gpio6_17	General-Purpose Input/Output	IO	J25
gpio6_18	General-Purpose Input/Output	IO	J24
gpio6_19	General-Purpose Input/Output	IO	H24
gpio6_20	General-Purpose Input/Output	IO	H25
gpio6_21	General-Purpose Input/Output	IO	U3
gpio6_22	General-Purpose Input/Output	IO	V4
gpio6_23	General-Purpose Input/Output	IO	V3
gpio6_24	General-Purpose Input/Output	IO	V2
gpio6_25	General-Purpose Input/Output	IO	W1
gpio6_26	General-Purpose Input/Output	IO	V1
gpio6_27	General-Purpose Input/Output	IO	U5
gpio6_28	General-Purpose Input/Output	IO	V5
gpio6_29	General-Purpose Input/Output	IO	Y2
gpio6_30	General-Purpose Input/Output	IO	Y1
gpio6_31	General-Purpose Input/Output	IO	Y4
<b>GPIO 7</b>			
gpio7_0	General-Purpose Input/Output	IO	AA2
gpio7_1	General-Purpose Input/Output	IO	AA3
gpio7_2	General-Purpose Input/Output	IO	W2
gpio7_3	General-Purpose Input/Output	IO	M1
gpio7_4	General-Purpose Input/Output	IO	M2
gpio7_5	General-Purpose Input/Output	IO	L2



**Table 4-19. GPIOs Signal Descriptions (continued)**

SIGNAL NAME	DESCRIPTION	TYPE	BALL
gpio7_6	General-Purpose Input/Output	IO	L1
gpio7_7	General-Purpose Input/Output	IO	C24
gpio7_8	General-Purpose Input/Output	IO	D24
gpio7_9	General-Purpose Input/Output	IO	D25
gpio7_10	General-Purpose Input/Output	IO	B24
gpio7_11	General-Purpose Input/Output	IO	C25
gpio7_12	General-Purpose Input/Output	IO	E24
gpio7_13	General-Purpose Input/Output	IO	E25
gpio7_14	General-Purpose Input/Output	IO	G25
gpio7_15	General-Purpose Input/Output	IO	F25
gpio7_16	General-Purpose Input/Output	IO	G24
gpio7_17	General-Purpose Input/Output	IO	F24
gpio7_18	General-Purpose Input/Output	IO	C2
gpio7_19	General-Purpose Input/Output	IO	D3
gpio7_22	General-Purpose Input/Output	IO	L25
gpio7_23	General-Purpose Input/Output	IO	M25
gpio7_24	General-Purpose Input/Output	IO	L20
gpio7_25	General-Purpose Input/Output	IO	M24
gpio7_26	General-Purpose Input/Output	IO	N23
gpio7_27	General-Purpose Input/Output	IO	N25
gpio7_28	General-Purpose Input/Output	IO	A2
gpio7_29	General-Purpose Input/Output	IO	B3
gpio7_30	General-Purpose Input/Output	IO	C17
gpio7_31	General-Purpose Input/Output	IO	C16
<b>GPIO 8</b>			
gpio8_27	General-Purpose Input	I	L23
gpio8_28	General-Purpose Input/Output	IO	J20
gpio8_29	General-Purpose Input/Output	IO	K25
gpio8_30 <sup>(1)</sup>	General-Purpose Input/Output	IO	C21
gpio8_31 <sup>(1)</sup>	General-Purpose Input/Output	IO	C22

(1) gpio8\_30 is multiplexed with EMU0 and gpio8\_31 is multiplexed with EMU1. These pins will be sampled at reset release by the test and emulation logic. Therefore, if they are used as GPIO pins, they must return to the high state whenever the device enters reset. This can be controlled by logic driven from rstoutn. After the device exits reset (indicated by rstoutn rising), these can return to GPIO mode.

### 4.3.19 PWM

---

#### NOTE

For more information, see the Pulse-Width Modulation (PWM) SS section of the device TRM.

---

**Table 4-20. PWM Signal Descriptions**

SIGNAL NAME	DESCRIPTION	TYPE	BALL
<b>PWMSS1</b>			
eCAP1_in_PWM1_out	ECAP1 Capture Input / PWM Output	IO	A7
ehrpwm1_synci	EHRPWM1 Sync Input	I	A9
ehrpwm1_synco	EHRPWM1 Sync Output	O	A8
ehrpwm1_tripzone_in put	EHRPWM1 Trip Zone Input	IO	B9
ehrpwm1A	EHRPWM1 Output A	O	B8

**Table 4-20. PWM Signal Descriptions (continued)**

SIGNAL NAME	DESCRIPTION	TYPE	BALL
ehrpwm1B	EHRPWM1 Output B	O	C8
eQEP1_index	EQEP1 Index Input	IO	C7
eQEP1_strobe	EQEP1 Strobe Input	IO	E8
eQEP1A_in	EQEP1 Quadrature Input A	I	D8
eQEP1B_in	EQEP1 Quadrature Input B	I	B7
<b>PWMSS2</b>			
eCAP2_in_PWM2_out	ECAP2 Capture Input / PWM Output	IO	B11, Y1
ehrpwm2_tripzone_in put	EHRPWM2 Trip Zone Input	IO	C10, Y2
ehrpwm2A	EHRPWM2 Output A	O	E10, Y5
ehrpwm2B	EHRPWM2 Output B	O	D10, Y6
eQEP2_index	EQEP2 Index Input	IO	A10
eQEP2_strobe	EQEP2 Strobe Input	IO	B10
eQEP2A_in	EQEP2 Quadrature Input A	I	A11
eQEP2B_in	EQEP2 Quadrature Input B	I	F10
<b>PWMSS3</b>			
eCAP3_in_PWM3_out	ECAP3 Capture Input / PWM Output	IO	AB1, B13
ehrpwm3_tripzone_in put	EHRPWM3 Trip Zone Input	IO	AA4, F11
ehrpwm3A	EHRPWM3 Output A	O	A13, Y3
ehrpwm3B	EHRPWM3 Output B	O	AA1, E11
eQEP3_index	EQEP3 Index Input	IO	AA3, B12
eQEP3_strobe	EQEP3 Strobe Input	IO	A12, W2
eQEP3A_in	EQEP3 Quadrature Input A	I	D11, Y4
eQEP3B_in	EQEP3 Quadrature Input B	I	AA2, C11

### 4.3.20 Emulation and Debug Subsystem

#### NOTE

For more information, see the On-Chip Debug Support / Debug Ports section of the device TRM.

**Table 4-21. Debug Signal Descriptions**

SIGNAL NAME	DESCRIPTION	TYPE	BALL
tms	JTAG test port mode select. An external pullup resistor should be used on this ball.	IO	L21
tdi	JTAG test data	I	L23
tdo	JTAG test port data	O	J20
tclk	JTAG test clock	I	K21
trstn	JTAG test reset	I	L22
rtck	JTAG return clock	O	K25
emu0 <sup>(1)</sup>	Emulator pin 0	IO	C21
emu1 <sup>(1)</sup>	Emulator pin 1	IO	C22
emu2	Emulator pin 2	IO	E14
emu3	Emulator pin 3	IO	F14
emu4	Emulator pin 4	IO	F13
emu5	Emulator pin 5	O	D8
emu6	Emulator pin 6	O	B7

**Table 4-21. Debug Signal Descriptions (continued)**

SIGNAL NAME	DESCRIPTION	TYPE	BALL
emu7	Emulator pin 7	O	C7
emu8	Emulator pin 8	O	E8
emu9	Emulator pin 9	O	B8
emu10	Emulator pin 10	O	C8
emu11	Emulator pin 11	O	B9
emu12	Emulator pin 12	O	A7
emu13	Emulator pin 13	O	A9
emu14	Emulator pin 14	O	A8
emu15	Emulator pin 15	O	A11
emu16	Emulator pin 16	O	F10
emu17	Emulator pin 17	O	A10
emu18	Emulator pin 18	O	B10
emu19	Emulator pin 19	O	E10

(1) EMU0 and EMU1 are multiplexed with GPIO. These pins will be sampled at reset release by the test and emulation logic. Therefore, if they are used as GPIO pins, they must return to the high state whenever the device enters reset. This can be controlled by logic driven from rstoutn. After the device exits reset (indicated by rstoutn rising), these can return to GPIO mode.

### 4.3.21 System and Miscellaneous

#### 4.3.21.1 Sysboot

---

#### NOTE

For more information, see the Initialization (ROM Code) section of the device TRM.

---

**Table 4-22. Sysboot Signal Descriptions**

SIGNAL NAME	DESCRIPTION	TYPE	BALL
sysboot0	Boot Mode Configuration 0. The value latched on this pin upon porz reset release will determine the boot mode configuration of the device.	I	F1
sysboot1	Boot Mode Configuration 1. The value latched on this pin upon porz reset release will determine the boot mode configuration of the device.	I	E2
sysboot2	Boot Mode Configuration 2. The value latched on this pin upon porz reset release will determine the boot mode configuration of the device.	I	E1
sysboot3	Boot Mode Configuration 3. The value latched on this pin upon porz reset release will determine the boot mode configuration of the device.	I	C1
sysboot4	Boot Mode Configuration 4. The value latched on this pin upon porz reset release will determine the boot mode configuration of the device.	I	D1
sysboot5	Boot Mode Configuration 5. The value latched on this pin upon porz reset release will determine the boot mode configuration of the device.	I	D2
sysboot6	Boot Mode Configuration 6. The value latched on this pin upon porz reset release will determine the boot mode configuration of the device.	I	B1
sysboot7	Boot Mode Configuration 7. The value latched on this pin upon porz reset release will determine the boot mode configuration of the device.	I	B2
sysboot8	Boot Mode Configuration 8. The value latched on this pin upon porz reset release will determine the boot mode configuration of the device.	I	C2
sysboot9	Boot Mode Configuration 9. The value latched on this pin upon porz reset release will determine the boot mode configuration of the device.	I	D3
sysboot10	Boot Mode Configuration 10. The value latched on this pin upon porz reset release will determine the boot mode configuration of the device.	I	A2
sysboot11	Boot Mode Configuration 11. The value latched on this pin upon porz reset release will determine the boot mode configuration of the device.	I	B3
sysboot12	Boot Mode Configuration 12. The value latched on this pin upon porz reset release will determine the boot mode configuration of the device.	I	C3

**Table 4-22. Sysboot Signal Descriptions (continued)**

SIGNAL NAME	DESCRIPTION	TYPE	BALL
sysboot13	Boot Mode Configuration 13. The value latched on this pin upon porz reset release will determine the boot mode configuration of the device.	I	C4
sysboot14	Boot Mode Configuration 14. The value latched on this pin upon porz reset release will determine the boot mode configuration of the device.	I	A3
sysboot15	Boot Mode Configuration 15. The value latched on this pin upon porz reset release will determine the boot mode configuration of the device.	I	B4

**4.3.21.2 Power, Reset, and Clock Management (PRCM)****NOTE**

For more information, see PRCM section of the device TRM.

**Table 4-23. PRCM Signal Descriptions**

SIGNAL NAME	DESCRIPTION	TYPE	BALL
clkout1	Device Clock output 1. Can be used externally for devices with non-critical timing requirements, or for debug, or as a reference clock on GPMC as described in <a href="#">Table 5-47 GPMC/NOR Flash Interface Switching Characteristics - Synchronous Mode - Default</a> and <a href="#">Table 5-49 GPMC/NOR Flash Interface Switching Characteristics - Synchronous Mode - Alternate</a> .	O	K23, L4
clkout2	Device Clock output 2. Can be used externally for devices with non-critical timing requirements, or for debug.	O	H5, J25
clkout3	Device Clock output 3. Can be used externally for devices with non-critical timing requirements, or for debug.	O	H25
porz	Power on Reset (active low) input must be asserted low during a device power up sequence or cold reset state when all supplies are disabled. Typically, an external PMIC is the source and sets porz high after all supplies reach valid operating levels. Asserting porz low puts the entire device in a safe reset state.	I	F19
resetn	Reset (active low) input's falling edge can trigger a device warm reset state from an external component. This signal should be high prior to or simultaneous with, porz rising. If the signal is not used in the system, resetn should be pulled high with an external pull-up resistor to vddshv3.	I	K24
rstoutn	Reset out (Active low) output is asserted low whenever any global reset condition exists. After a brief delay, it will be set high upon removal of the internal global reset condition (i.e. porz, warm reset). It is only functional after its output buffer's reference voltage (vddshv3) is valid. If it is used as a reset for device peripheral components, then it should be AND gated with porz to avoid the possibility of reset signal glitches during a power up sequence. <sup>(2)</sup>	O	E20
xi_osc0	System Oscillator OSC0 Crystal input / LVCMOS clock input. Functions as the input connection to a crystal when the internal oscillator OSC0 is used. Functions as an LVCMOS-compatible input clock when an external oscillator is used.	I	Y12
xi_osc1	Auxiliary Oscillator OSC1 Crystal input / LVCMOS clock input. Functions as the input connection to a crystal when the internal oscillator OSC1 is used. Functions as an LVCMOS-compatible input clock when an external oscillator is used.	I	AC11
xo_osc0	System Oscillator OSC0 Crystal output	O	AB12
xo_osc1	Auxiliary Oscillator OSC1 Crystal output	O	AA11
xref_clk0	External Reference Clock 0. For Audio and other Peripherals.	I	J25
xref_clk1	External Reference Clock 1. For Audio and other Peripherals.	I	J24
xref_clk2	External Reference Clock 2. For Audio and other Peripherals.	I	H24
xref_clk3	External Reference Clock 3. For Audio and other Peripherals.	I	H25

**Table 4-23. PRCM Signal Descriptions (continued)**

SIGNAL NAME	DESCRIPTION	TYPE	BALL
RMII_MHZ_50_CLK <sup>(1)</sup>	RMII Reference Clock (50MHz). This pin is an input when external reference is used or output when internal reference is used.	IO	P5

- (1) This clock signal is implemented as 'pad loopback' inside the device - the output signal is looped back through the input buffer to serve as the internal reference signal. Series termination is recommended (as close to device pin as possible) to improve signal integrity of the clock input. Any nonmonotonicity in voltage that occurs at the pad loopback clock pin between  $V_{IH}$  and  $V_{IL}$  must be less than  $V_{HYS}$ .
- (2) Note that rstoutn is only valid after vddshv3 is valid. If the rstoutn signal will be used as a reset into other devices attached to the SOC, it must be AND'ed with porz. This will prevent glitches occurring during supply ramping being propagated.

#### 4.3.21.3 System Direct Memory Access (SDMA)

---

**NOTE**

For more information, see the DMA Controllers / System DMA section of the device TRM.

---

**Table 4-24. SDMA Signal Descriptions**

SIGNAL NAME	DESCRIPTION	TYPE	BALL
dma_evt1	System DMA Event Input 1	I	G1, L4
dma_evt2	System DMA Event Input 2	I	H3, H5
dma_evt3	System DMA Event Input 3	I	H2
dma_evt4	System DMA Event Input 4	I	H6

#### 4.3.21.4 Interrupt Controllers (INTC)

---

**NOTE**

For more information, see the Interrupt Controllers section of the device TRM.

---

**Table 4-25. INTC Signal Descriptions**

SIGNAL NAME	DESCRIPTION	TYPE	BALL
nmin_dsp	Non maskable interrupt input, active-low. This pin can be optionally routed to the DSP NMI input or as generic input to the Arm cores. Note that by default this pin has an internal pulldown resistor enabled. This internal pulldown should be disabled or countered by a stronger external pullup resistor before routing to the DSP or Arm processors.	I	L24
sys_nirq2	External interrupt event to any device INTC	I	AC10
sys_nirq1	External interrupt event to any device INTC	I	AB10

#### 4.3.22 Power Supplies

---

**NOTE**

For more information, see Power, Reset, and Clock Management / PRCM Subsystem Environment / External Voltage Inputs section of the device TRM.

---

**Table 4-26. Power Supply Signal Descriptions**

SIGNAL NAME	DESCRIPTION	TYPE	BALL
vdd	Core voltage domain supply	PWR	J15, J16, J18, K12, K18, L12, L17, M11, M13, M15, M17, N11, N13, N15, N18, P10, P12, P14, P16, P18, R10, R12, R14, R16, R17, T11, T13, T15, T17, T9, U11, U13, U15, U18, U9, V10, V12, V14, V16, V18, W10, W12, W14, W16
vpp <sup>(2)</sup>	eFuse power supply	PWR	F20
vss	Ground	GND	A1, A25, AA13, AA15, AA7, AA8, AA9, AB8, AC13, AE1, AE15, AE25, G13, G16, G8, H10, H12, H14, H16, H18, H19, H8, J10, J12, J14, J17, K11, K13, K15, K17, K9, L11, L13, L15, L18, L8, M12, M14, M16, M18, M20, M8, M9, N12, N14, N16, N17, N20, P11, P13, P15, P17, P19, P9, R11, R13, R15, R18, R19, R8, R9, T10, T12, T14, T16, T18, T8, U10, U12, U14, U16, U17, U19, V11, V13, V15, V17, V19, V8, V9, W19, W9, Y14, Y16, Y17, Y7
cap_vbbldo_gpu <sup>(1)</sup>	MM (SGX) Back bias supply	CAP	T7
cap_vbbldo_iva <sup>(1)</sup>	IVA Back bias supply	CAP	G14
cap_vbbldo_mpu <sup>(1)</sup>	MPU back bias supply	CAP	F17
cap_vbbldo_dsp <sup>(1)</sup>	External capacitor connection for the DSP vbb ldo output	CAP	F8
cap_vddram_core1 <sup>(1)</sup>	SRAM array supply for core memories	CAP	U20
cap_vddram_core3 <sup>(1)</sup>	SRAM array supply for core memories	CAP	K7
cap_vddram_core4 <sup>(1)</sup>	SRAM array supply for core memories	CAP	G19
cap_vddram_gpu <sup>(1)</sup>	SRAM array supply for SGX (MM) memories	CAP	V7
cap_vddram_iva <sup>(1)</sup>	SRAM array supply for IVA memories	CAP	G12
cap_vddram_dsp <sup>(1)</sup>	External capacitor connection for the DSP	CAP	L7
cap_vddram_mpu <sup>(1)</sup>	External capacitor connection for the MPU SRAM array ldo output	CAP	G18
vdda33v_usb1	HS USB1 3p3 supply	PWR	AA10
vdda33v_usb2	HS USB1 3p3 supply	PWR	Y10
vdda_core_gmac	DPLL_CORE and CORE HSDIVIDER analog power supply	PWR	L9
vdda_csi	CSI Interface 1.8v Supply	PWR	T6
vdda_dsp_iva	DSP PLL and IVA PLL analog power supply	PWR	K10, L10
vdda_mpu_abe	MPU_ABE PLL analog power supply	PWR	K16, L16
vdda_per	DPLL_ABE, DPLL_PER, and PER HSDIVIDER analog power supply	PWR	M10
vdda_usb2	HS USB2 1.8V analog power supply	PWR	Y8
vdds_mlbp	MLBP IO power supply	PWR	P7, R7
vdd_dsp	DSP voltage domain supply	PWR	H11, H13, H9, J11, J13, J9
vdda_ddr	DDR PLL and DDR HSDIVIDER analog power supply	PWR	R20

**Table 4-26. Power Supply Signal Descriptions (continued)**

SIGNAL NAME	DESCRIPTION	TYPE	BALL
vdda_debug	Debug PLL inside IOSCLL supply	PWR	N10
vdda_gpu	GPU (SGX) PLL analog power supply	PWR	N9
vdda_hdmi	HDMI PLL and HDMI analog power supply	PWR	W15, Y15
vdda_osc	HFOSC - 1.8v vdds supply	PWR	W13, Y13
vdda_pcie	PCIe PLL analog power supply	PWR	W11, Y11
vdda_usb1	USB2 PLL analog power supply	PWR	W8
vdda_usb3	USB3 PLL analog power supply	PWR	Y9
vdda_video	VIDEO1 and VIDEO2 PLL analog power supply	PWR	K14, L14
vdds18v	1.8V bump added for atestv esd supply	PWR	G11, H20, W7, Y18
vdds18v_dds1	DDR2 - 1.8v bias supply	PWR	AA19, P20, Y19
vddshv1	VIN2 domain - 1.8/3.3 mode voltage Power cell - secondary power supply	PWR	G10, G9
vddshv3	GENERAL Domain - 1.8/3.3 mode voltage Power cell - secondary power supply	PWR	G15, G17, H15, H17, J19, K19
vddshv4	MMC4 Domain (UART4) - 1.8/3.3 mode voltage Power cell - secondary power supply	PWR	M19, N19
vddshv7	WIFI Power Group (MMC3/McASP5) - 1.8/3.3 mode voltage Power cell - secondary power supply	PWR	U7, U8
vddshv8	Dual Voltage (1.8V or 3.3V) power supply for the MMC1 Power Group pins	PWR	N8, P8
vddshv9	RGMII - 1.8/3.3 mode voltage Power cell - secondary power supply	PWR	M7, N7
vddshv10	GPMC - 1.8/3.3 mode voltage Power cell - secondary power supply	PWR	J7, J8, K8
vddshv11	MMC2 - 1.8/3.3 mode voltage Power cell - secondary power supply	PWR	F7, G7, H7
vdds_dds1	DDR2 - vdds2 can be 1.8 (dds2)/1.5(dds3) - secondary power supply	PWR	T19, T20, V20, W17, W18, W20
vssa_osc0	OSC0 Analog ground	GND	AA12
vssa_osc1	OSC1 Analog ground	GND	AB11

- (1) This pin must always be connected via a 1- $\mu$ F capacitor to vss.
- (2) This signal is valid only for High-Security devices. For more details, see [Section 5.8 VPP Specification for One-Time Programmable \(OTP\) eFUSES](#). For General Purpose devices do not connect any signal, test point, or board trace to this signal.

## 4.4 Pin Multiplexing

[Table 4-27](#) describes the device pin multiplexing (no characteristics are provided in this table).

---

### NOTE

[Table 4-27](#), *Pin Multiplexing* doesn't take into account subsystem multiplexing signals. Subsystem multiplexing signals are described in [Section 4.3](#), *Signal Descriptions*.

---

### NOTE

For more information, see the Control Module / Control Module Functional Description / PAD Functional Multiplexing and Configuration section of the Device TRM.

---

### NOTE

Configuring two pins to the same input signal is not supported as it can yield unexpected results. This can be easily prevented with the proper software configuration (Hi-Z mode is not an input signal).

---

### NOTE

When a pad is set into a pin multiplexing mode which is not defined, that pad's behavior is undefined. This should be avoided.

---

### NOTE

In some cases [Table 4-27](#) may present more than one signal per muxmode for the same ball. First signal in the list is the dominant function as selected via CTRL\_CORE\_PAD\_\* register.

All other signals are virtual functions that present alternate multiplexing options. This virtual functions are controlled via CTRL\_CORE\_ALT\_SELECT\_MUX or CTRL\_CORE\_VIP\_MUX\_SELECT register. For more information on how to use this options, please refer to Device TRM, Chapter *Control Module*, Section *Pad Configuration Registers*.

---

### NOTE

Dual rank support is not available on this device, but signal names are retained for consistency with the TDA2xx family of devices.

---



**Table 4-27. Pin Multiplexing**

ADDRESS	REGISTER NAME	BALL NUMBER	MUXMODE FIELD SETTINGS (CTRL_CORE_PAD_*[3:0])												
			0	1	2	3	4*	5	6*	7	8	9	10	14*	15
		P25	ddr1_dqm3												
		Y23	ddr1_d10												
		P21	ddr1_d27												
		U25	ddr1_d17												
		AA20	ddr1_a7												
		V25	ddr1_dqsn2												
		AB16	ddr1_ba2												
		T25	ddr1_d25												
		N21	ddr1_d28												
		AB25	ddr1_d13												
		AE9	hdmi1_clockx												
		W23	ddr1_d16												
		AC24	ddr1_d1												
		AD16	ddr1_casn												
		AA23	ddr1_d0												
		AD18	ddr1_odt0												
		AE19	ddr1_a1												
		AC20	ddr1_a9												
		U21	ddr1_dqm2												
		AA24	ddr1_d8												
		AC11	xi_osc1												
		AD1	csi2_0_dx1												
		AE3	usb_txn0	pcie_txn1											
		AC6	usb1_dp												
		AD6	usb_rxp0	pcie_rxp1											
		AA16	ddr1_ba1												
		Y12	xi_osc0												
		AB15	ddr1_a14												
		AC18	ddr1_a0												
		AE11	hdmi1_data0x												
		R25	ddr1_dqsn3												
		Y24	ddr1_dqs1												
		Y21	ddr1_a8												
		W21	ddr1_d19												
		AD20	ddr1_a4												
		AA25	ddr1_d14												
		AD13	hdmi1_data1y												
		AB9	ljcb_clkn												

Table 4-27. Pin Multiplexing (continued)

ADDRESS	REGISTER NAME	BALL NUMBER	MUXMODE FIELD SETTINGS (CTRL_CORE_PAD_*[3:0])														
			0	1	2	3	4*	5	6*	7	8	9	10	14*	15		
		AC25	ddr1_d12														
		U22	ddr1_d21														
		AB23	ddr1_d4														
		AB24	ddr1_d2														
		AE16	ddr1_ba0														
		T22	ddr1_d20														
		T21	ddr1_d23														
		AB19	ddr1_a3														
		AE24	ddr1_d7														
		AC15	ddr1_a13														
		AC21	ddr1_a11														
		AD17	ddr1_rasn														
		AB12	xo_osc0														
		AD23	ddr1_d6														
		AD9	pcie_txp0														
		V24	ddr1_dqs2														
		U23	ddr1_d22														
		AC22	ddr1_a12														
		AD24	ddr1_d3														
		AC8	ljcb_clkp														
		AE21	ddr1_nck														
		Y20	ddr1_vref0														
		AD7	pcie_rxp0														
		AE23	ddr1_dqm0														
		AD21	ddr1_ck														
		Y25	ddr1_dqsn1														
		AA11	xo_osc1														
		AE17	ddr1_rst														
		W22	ddr1_dqm1														
		AE12	hdmi1_data1x														
		AE14	hdmi1_data2x														
		AB2	csi2_0_dy0														
		AB18	ddr1_cke														
		AB6	usb2_dp														
		AC1	csi2_0_dx0														
		AE8	pcie_txn0														
		AC19	ddr1_csn0														
		AA21	ddr1_a10														
		AE6	pcie_rxn0														

**Table 4-27. Pin Multiplexing (continued)**

ADDRESS	REGISTER NAME	BALL NUMBER	MUXMODE FIELD SETTINGS (CTRL_CORE_PAD_*[3:0])														
			0	1	2	3	4*	5	6*	7	8	9	10	14*	15		
		AB7	usb1_dm														
		F19	porz														
		W25	ddr1_d9														
		P24	ddr1_d31														
		AD22	ddr1_dqs0														
		P22	ddr1_d29														
		U24	ddr1_d18														
		AD2	csi2_0_dy2														
		AE18	ddr1_wen														
		AE20	ddr1_a5														
		W24	ddr1_d15														
		T24	ddr1_d26														
		R24	ddr1_dqs3														
		AD15	hdmi1_data2y														
		AE22	ddr1_dqsn0														
		AA18	ddr1_a6														
		AC2	csi2_0_dy1														
		AD12	hdmi1_data0y														
		T23	ddr1_d24														
		AD10	hdmi1_clocky														
		AE5	usb_rxn0	pcie_rxn1													
		AE2	csi2_0_dx2														
		P23	ddr1_d30														
		AC5	usb2_dm														
		AC23	ddr1_d5														
		AD19	ddr1_a2														
		AC16	ddr1_a15														
		AD25	ddr1_d11														
		AD4	usb_txp0	pcie_txp1													
0x1400	CTRL_CORE_PAD_GPMC_AD0	F1	gpmc_ad0		vin1a_d0	vout3_d0									gpio1_6	sysboot0	
0x1404	CTRL_CORE_PAD_GPMC_AD1	E2	gpmc_ad1		vin1a_d1	vout3_d1									gpio1_7	sysboot1	
0x1408	CTRL_CORE_PAD_GPMC_AD2	E1	gpmc_ad2		vin1a_d2	vout3_d2									gpio1_8	sysboot2	
0x140C	CTRL_CORE_PAD_GPMC_AD3	C1	gpmc_ad3		vin1a_d3	vout3_d3									gpio1_9	sysboot3	
0x1410	CTRL_CORE_PAD_GPMC_AD4	D1	gpmc_ad4		vin1a_d4	vout3_d4									gpio1_10	sysboot4	
0x1414	CTRL_CORE_PAD_GPMC_AD5	D2	gpmc_ad5		vin1a_d5	vout3_d5									gpio1_11	sysboot5	

Table 4-27. Pin Multiplexing (continued)

ADDRESS	REGISTER NAME	BALL NUMBER	MUXMODE FIELD SETTINGS (CTRL_CORE_PAD_*[3:0])													
			0	1	2	3	4*	5	6*	7	8	9	10	14*	15	
0x1418	CTRL_CORE_PAD_GPMC_AD6	B1	gpmc_ad6		vin1a_d6	vout3_d6									gpio1_12	sysboot6
0x141C	CTRL_CORE_PAD_GPMC_AD7	B2	gpmc_ad7		vin1a_d7	vout3_d7									gpio1_13	sysboot7
0x1420	CTRL_CORE_PAD_GPMC_AD8	C2	gpmc_ad8		vin1a_d8	vout3_d8									gpio7_18	sysboot8
0x1424	CTRL_CORE_PAD_GPMC_AD9	D3	gpmc_ad9		vin1a_d9	vout3_d9									gpio7_19	sysboot9
0x1428	CTRL_CORE_PAD_GPMC_AD10	A2	gpmc_ad10		vin1a_d10	vout3_d10									gpio7_28	sysboot10
0x142C	CTRL_CORE_PAD_GPMC_AD11	B3	gpmc_ad11		vin1a_d11	vout3_d11									gpio7_29	sysboot11
0x1430	CTRL_CORE_PAD_GPMC_AD12	C3	gpmc_ad12		vin1a_d12	vout3_d12									gpio1_18	sysboot12
0x1434	CTRL_CORE_PAD_GPMC_AD13	C4	gpmc_ad13		vin1a_d13	vout3_d13									gpio1_19	sysboot13
0x1438	CTRL_CORE_PAD_GPMC_AD14	A3	gpmc_ad14		vin1a_d14	vout3_d14									gpio1_20	sysboot14
0x143C	CTRL_CORE_PAD_GPMC_AD15	B4	gpmc_ad15		vin1a_d15	vout3_d15									gpio1_21	sysboot15
0x1440	CTRL_CORE_PAD_GPMC_A0	M1	gpmc_a0		vin1a_d16	vout3_d16			vin1b_d0	i2c4_scl	uart5_rxd			gpio7_3 gpmc_a26 gpmc_a16	Driver off	
0x1444	CTRL_CORE_PAD_GPMC_A1	M2	gpmc_a1		vin1a_d17	vout3_d17			vin1b_d1	i2c4_sda	uart5_txd			gpio7_4	Driver off	
0x1448	CTRL_CORE_PAD_GPMC_A2	L2	gpmc_a2		vin1a_d18	vout3_d18			vin1b_d2	uart7_rxd	uart5_ctsn			gpio7_5	Driver off	
0x144C	CTRL_CORE_PAD_GPMC_A3	L1	gpmc_a3	qspi1_cs2	vin1a_d19	vout3_d19			vin1b_d3	uart7_txd	uart5_rtsn			gpio7_6	Driver off	
0x1450	CTRL_CORE_PAD_GPMC_A4	K3	gpmc_a4	qspi1_cs3	vin1a_d20	vout3_d20			vin1b_d4	i2c5_scl	uart6_rxd			gpio1_26	Driver off	
0x1454	CTRL_CORE_PAD_GPMC_A5	K2	gpmc_a5		vin1a_d21	vout3_d21			vin1b_d5	i2c5_sda	uart6_txd			gpio1_27	Driver off	
0x1458	CTRL_CORE_PAD_GPMC_A6	J1	gpmc_a6		vin1a_d22	vout3_d22			vin1b_d6	uart8_rxd	uart6_ctsn			gpio1_28	Driver off	
0x145C	CTRL_CORE_PAD_GPMC_A7	K1	gpmc_a7		vin1a_d23	vout3_d23			vin1b_d7	uart8_txd	uart6_rtsn			gpio1_29	Driver off	
0x1460	CTRL_CORE_PAD_GPMC_A8	K4	gpmc_a8		vin1a_hsync0	vout3_hsync			vin1b_hsync1	timer12	spi4_sclk			gpio1_30	Driver off	
0x1464	CTRL_CORE_PAD_GPMC_A9	H1	gpmc_a9		vin1a_vsync0	vout3_vsync			vin1b_vsync1	timer11	spi4_d1			gpio1_31	Driver off	
0x1468	CTRL_CORE_PAD_GPMC_A10	J2	gpmc_a10		vin1a_de0	vout3_de			vin1b_clk1	timer10	spi4_d0			gpio2_0	Driver off	
0x146C	CTRL_CORE_PAD_GPMC_A11	L3	gpmc_a11		vin1a_fld0	vout3_fld			vin1b_de1	timer9	spi4_cs0			gpio2_1	Driver off	
0x1470	CTRL_CORE_PAD_GPMC_A12	G1	gpmc_a12					gpmc_a0	vin1b_fld1	timer8	spi4_cs1	dma_evt1		gpio2_2	Driver off	

**Table 4-27. Pin Multiplexing (continued)**

ADDRESS	REGISTER NAME	BALL NUMBER	MUXMODE FIELD SETTINGS (CTRL_CORE_PAD_*[3:0])													
			0	1	2	3	4*	5	6*	7	8	9	10	14*	15	
0x1474	CTRL_CORE_PAD_GPMC_A13	H3	gpmc_a13	qspi1_rtclk							timer7	spi4_cs2	dma_evt2		gpio2_3	Driver off
0x1478	CTRL_CORE_PAD_GPMC_A14	H4	gpmc_a14	qspi1_d3							timer6	spi4_cs3			gpio2_4	Driver off
0x147C	CTRL_CORE_PAD_GPMC_A15	K6	gpmc_a15	qspi1_d2							timer5				gpio2_5	Driver off
0x1480	CTRL_CORE_PAD_GPMC_A16	K5	gpmc_a16	qspi1_d0											gpio2_6	Driver off
0x1484	CTRL_CORE_PAD_GPMC_A17	G2	gpmc_a17	qspi1_d1											gpio2_7	Driver off
0x1488	CTRL_CORE_PAD_GPMC_A18	F2	gpmc_a18	qspi1_sclk											gpio2_8	Driver off
0x148C	CTRL_CORE_PAD_GPMC_A19	A4	gpmc_a19	mmc2_dat4	gpmc_a13					vin2b_d0					gpio2_9	Driver off
0x1490	CTRL_CORE_PAD_GPMC_A20	E7	gpmc_a20	mmc2_dat5	gpmc_a14					vin2b_d1					gpio2_10	Driver off
0x1494	CTRL_CORE_PAD_GPMC_A21	D6	gpmc_a21	mmc2_dat6	gpmc_a15					vin2b_d2					gpio2_11	Driver off
0x1498	CTRL_CORE_PAD_GPMC_A22	C5	gpmc_a22	mmc2_dat7	gpmc_a16					vin2b_d3					gpio2_12	Driver off
0x149C	CTRL_CORE_PAD_GPMC_A23	B5	gpmc_a23	mmc2_clk	gpmc_a17					vin2b_d4					gpio2_13	Driver off
0x14A0	CTRL_CORE_PAD_GPMC_A24	D7	gpmc_a24	mmc2_dat0	gpmc_a18					vin2b_d5					gpio2_14	Driver off
0x14A4	CTRL_CORE_PAD_GPMC_A25	C6	gpmc_a25	mmc2_dat1	gpmc_a19					vin2b_d6					gpio2_15	Driver off
0x14A8	CTRL_CORE_PAD_GPMC_A26	A5	gpmc_a26	mmc2_dat2	gpmc_a20					vin2b_d7					gpio2_16	Driver off
0x14AC	CTRL_CORE_PAD_GPMC_A27	B6	gpmc_a27	mmc2_dat3	gpmc_a21					vin2b_hsync1					gpio2_17	Driver off
0x14B0	CTRL_CORE_PAD_GPMC_CS1	A6	gpmc_cs1	mmc2_cmd	gpmc_a22					vin2b_vsync1					gpio2_18	Driver off
0x14B4	CTRL_CORE_PAD_GPMC_CS0	F3	gpmc_cs0												gpio2_19	Driver off
0x14B8	CTRL_CORE_PAD_GPMC_CS2	G4	gpmc_cs2	qspi1_cs0											gpio2_20 gpmc_a23 gpmc_a13	Driver off
0x14BC	CTRL_CORE_PAD_GPMC_CS3	G3	gpmc_cs3	qspi1_cs1	vin1a_clk0	vout3_clk		gpmc_a1							gpio2_21 gpmc_a24 gpmc_a14	Driver off
0x14C0	CTRL_CORE_PAD_GPMC_CLK	L4	gpmc_clk	gpmc_cs7	clkout1	gpmc_wait1			vin2b_clk1	timer4	i2c3_scl	dma_evt1		gpio2_22 gpmc_a20	Driver off	
0x14C4	CTRL_CORE_PAD_GPMC_ADV_NALE	H5	gpmc_adv_nale	gpmc_cs6	clkout2	gpmc_wait1		gpmc_a2	gpmc_a23	timer3	i2c3_sda	dma_evt2		gpio2_23 gpmc_a19	Driver off	
0x14C8	CTRL_CORE_PAD_GPMC_OEN_REN	G5	gpmc_oen_ren											gpio2_24	Driver off	
0x14CC	CTRL_CORE_PAD_GPMC_WEN	G6	gpmc_wen											gpio2_25	Driver off	

**Table 4-27. Pin Multiplexing (continued)**

ADDRESS	REGISTER NAME	BALL NUMBER	MUXMODE FIELD SETTINGS (CTRL_CORE_PAD_*[3:0])												
			0	1	2	3	4*	5	6*	7	8	9	10	14*	15
0x14D0	CTRL_CORE_PAD_GPMC_BEN0	H2	gpmc_ben0	gpmc_cs4					vin2b_de1	timer2		dma_evt3		gpio2_26 gpmc_a21	Driver off
0x14D4	CTRL_CORE_PAD_GPMC_BEN1	H6	gpmc_ben1	gpmc_cs5			vin2b_clk1	gpmc_a3	vin2b_fld1	timer1		dma_evt4		gpio2_27 gpmc_a22	Driver off
0x14D8	CTRL_CORE_PAD_GPMC_WAIT0	F6	gpmc_wait0											gpio2_28 gpmc_a25 gpmc_a15	Driver off
0x1554	CTRL_CORE_PAD_VIN2A_CLK0	D8	vin2a_clk0				vout2_fld	emu5					eQEP1A_in	gpio3_28 gpmc_a27 gpmc_a17	Driver off
0x1558	CTRL_CORE_PAD_VIN2A_DE0	B7	vin2a_de0	vin2a_fld0	vin2b_fld1	vin2b_de1	vout2_de	emu6					eQEP1B_in	gpio3_29	Driver off
0x155C	CTRL_CORE_PAD_VIN2A_FLD0	C7	vin2a_fld0		vin2b_clk1		vout2_clk	emu7					eQEP1_index	gpio3_30 gpmc_a27 gpmc_a18	Driver off
0x1560	CTRL_CORE_PAD_VIN2A_HSYNC0	E8	vin2a_hsync0			vin2b_hsync1	vout2_hsync	emu8		uart9_rxd	spi4_sclk		eQEP1_strobe	gpio3_31 gpmc_a27	Driver off
0x1564	CTRL_CORE_PAD_VIN2A_VSYNC0	B8	vin2a_vsync0			vin2b_vsync1	vout2_vsync	emu9		uart9_txd	spi4_d1		ehrpwm1A	gpio4_0	Driver off
0x1568	CTRL_CORE_PAD_VIN2A_D0	C8	vin2a_d0				vout2_d23	emu10		uart9_ctsn	spi4_d0		ehrpwm1B	gpio4_1	Driver off
0x156C	CTRL_CORE_PAD_VIN2A_D1	B9	vin2a_d1				vout2_d22	emu11		uart9_rtsn	spi4_cs0		ehrpwm1_trip zone_input	gpio4_2	Driver off
0x1570	CTRL_CORE_PAD_VIN2A_D2	A7	vin2a_d2				vout2_d21	emu12			uart10_rxd		eCAP1_in_PWM1_out	gpio4_3	Driver off
0x1574	CTRL_CORE_PAD_VIN2A_D3	A9	vin2a_d3				vout2_d20	emu13			uart10_txd		ehrpwm1_syn ci	gpio4_4	Driver off
0x1578	CTRL_CORE_PAD_VIN2A_D4	A8	vin2a_d4				vout2_d19	emu14			uart10_ctsn		ehrpwm1_syn co	gpio4_5	Driver off
0x157C	CTRL_CORE_PAD_VIN2A_D5	A11	vin2a_d5				vout2_d18	emu15			uart10_rtsn		eQEP2A_in	gpio4_6	Driver off
0x1580	CTRL_CORE_PAD_VIN2A_D6	F10	vin2a_d6				vout2_d17	emu16			mii1_rxd1		eQEP2B_in	gpio4_7	Driver off
0x1584	CTRL_CORE_PAD_VIN2A_D7	A10	vin2a_d7				vout2_d16	emu17			mii1_rxd2		eQEP2_index	gpio4_8	Driver off
0x1588	CTRL_CORE_PAD_VIN2A_D8	B10	vin2a_d8				vout2_d15	emu18			mii1_rxd3		eQEP2_strobe	gpio4_9 gpmc_a26	Driver off
0x158C	CTRL_CORE_PAD_VIN2A_D9	E10	vin2a_d9				vout2_d14	emu19			mii1_rxd0		ehrpwm2A	gpio4_10 gpmc_a25	Driver off
0x1590	CTRL_CORE_PAD_VIN2A_D10	D10	vin2a_d10			mdio_mclk	vout2_d13						ehrpwm2B	gpio4_11 gpmc_a24	Driver off
0x1594	CTRL_CORE_PAD_VIN2A_D11	C10	vin2a_d11			mdio_d	vout2_d12						ehrpwm2_trip zone_input	gpio4_12 gpmc_a23	Driver off
0x1598	CTRL_CORE_PAD_VIN2A_D12	B11	vin2a_d12			rgmii1_txc	vout2_d11				mii1_rxclk		eCAP2_in_PWM2_out	gpio4_13	Driver off
0x159C	CTRL_CORE_PAD_VIN2A_D13	D11	vin2a_d13			rgmii1_txctl	vout2_d10				mii1_rxdv		eQEP3A_in	gpio4_14	Driver off

**Table 4-27. Pin Multiplexing (continued)**

ADDRESS	REGISTER NAME	BALL NUMBER	MUXMODE FIELD SETTINGS (CTRL_CORE_PAD_*[3:0])													
			0	1	2	3	4*	5	6*	7	8	9	10	14*	15	
0x15A0	CTRL_CORE_PAD_VIN2A_D14	C11	vin2a_d14			rgmii1_txd3	vout2_d9					mii1_txclk		eQEP3B_in	gpio4_15	Driver off
0x15A4	CTRL_CORE_PAD_VIN2A_D15	B12	vin2a_d15			rgmii1_txd2	vout2_d8					mii1_txd0		eQEP3_index	gpio4_16	Driver off
0x15A8	CTRL_CORE_PAD_VIN2A_D16	A12	vin2a_d16		vin2b_d7	rgmii1_txd1	vout2_d7					mii1_txd1		eQEP3_strobe	gpio4_24	Driver off
0x15AC	CTRL_CORE_PAD_VIN2A_D17	A13	vin2a_d17		vin2b_d6	rgmii1_txd0	vout2_d6					mii1_txd2		ehrpwm3A	gpio4_25	Driver off
0x15B0	CTRL_CORE_PAD_VIN2A_D18	E11	vin2a_d18		vin2b_d5	rgmii1_rxc	vout2_d5					mii1_txd3		ehrpwm3B	gpio4_26	Driver off
0x15B4	CTRL_CORE_PAD_VIN2A_D19	F11	vin2a_d19		vin2b_d4	rgmii1_rxtl	vout2_d4					mii1_txer		ehrpwm3_tripzone_input	gpio4_27	Driver off
0x15B8	CTRL_CORE_PAD_VIN2A_D20	B13	vin2a_d20		vin2b_d3	rgmii1_rxd3	vout2_d3					mii1_rxer		eCAP3_in_PWM3_out	gpio4_28	Driver off
0x15BC	CTRL_CORE_PAD_VIN2A_D21	E13	vin2a_d21		vin2b_d2	rgmii1_rxd2	vout2_d2					mii1_col			gpio4_29	Driver off
0x15C0	CTRL_CORE_PAD_VIN2A_D22	C13	vin2a_d22		vin2b_d1	rgmii1_rxd1	vout2_d1					mii1_crs			gpio4_30	Driver off
0x15C4	CTRL_CORE_PAD_VIN2A_D23	D13	vin2a_d23		vin2b_d0	rgmii1_rxd0	vout2_d0					mii1_txen			gpio4_31	Driver off
0x15E4	CTRL_CORE_PAD_OUT1_D2	E14			emu2											
0x1604	CTRL_CORE_PAD_OUT1_D10	F14			emu3											
0x1624	CTRL_CORE_PAD_OUT1_D18	F13			emu4											
0x163C	CTRL_CORE_PAD_MDI0_MCLK	L5	mdio_mclk	uart3_rtsn		mii0_col	vin2a_clk0	vin1b_clk1							gpio5_15	Driver off
0x1640	CTRL_CORE_PAD_MDI0_D	L6	mdio_d	uart3_ctsn		mii0_txer	vin2a_d0	vin1b_d0							gpio5_16	Driver off
0x1644	CTRL_CORE_PAD_RMII_MHZ_50_CLK	P5	RMII_MHZ_50_CLK				vin2a_d11								gpio5_17	Driver off
0x1648	CTRL_CORE_PAD_UART3_RXD	N5	uart3_rxd		rmii1_crs	mii0_rxdv	vin2a_d1	vin1b_d1			spi3_sclk				gpio5_18	Driver off
0x164C	CTRL_CORE_PAD_UART3_TXD	N6	uart3_txd		rmii1_rxer	mii0_rxc	vin2a_d2	vin1b_d2			spi3_d1	spi4_cs1			gpio5_19	Driver off
0x1650	CTRL_CORE_PAD_GMII0_TXC	T4	rgmii0_txc	uart3_ctsn	rmii1_rxd1	mii0_rxd3	vin2a_d3	vin1b_d3	usb3_ulpi_clk	spi3_d0	spi4_cs2				gpio5_20	Driver off
0x1654	CTRL_CORE_PAD_GMII0_TXCTL	T5	rgmii0_txcctl	uart3_rtsn	rmii1_rxd0	mii0_rxd2	vin2a_d4	vin1b_d4	usb3_ulpi_stp	spi3_cs0	spi4_cs3				gpio5_21	Driver off
0x1658	CTRL_CORE_PAD_GMII0_TXD3	P4	rgmii0_txd3	rmii0_crs		mii0_crs	vin2a_de0	vin1b_de1	usb3_ulpi_dir	spi4_sclk	uart4_rxd				gpio5_22	Driver off
0x165C	CTRL_CORE_PAD_GMII0_TXD2	P3	rgmii0_txd2	rmii0_rxer		mii0_rxer	vin2a_hsync0	vin1b_hsync1	usb3_ulpi_nxt	spi4_d1	uart4_txd				gpio5_23	Driver off
0x1660	CTRL_CORE_PAD_GMII0_TXD1	R2	rgmii0_txd1	rmii0_rxd1		mii0_rxd1	vin2a_vsync0	vin1b_vsync1	usb3_ulpi_d0	spi4_d0	uart4_ctsn				gpio5_24	Driver off
0x1664	CTRL_CORE_PAD_GMII0_TXD0	R1	rgmii0_txd0	rmii0_rxd0		mii0_rxd0	vin2a_d10		usb3_ulpi_d1	spi4_cs0	uart4_rtsn				gpio5_25	Driver off

**Table 4-27. Pin Multiplexing (continued)**

ADDRESS	REGISTER NAME	BALL NUMBER	MUXMODE FIELD SETTINGS (CTRL_CORE_PAD_*[3:0])												
			0	1	2	3	4*	5	6*	7	8	9	10	14*	15
0x1668	CTRL_CORE_PAD_R_GMII0_RXC	N2	rgmii0_rxc		rmii1_txen	mii0_txclk	vin2a_d5	vin1b_d5	usb3_ulpi_d2					gpio5_26	Driver off
0x166C	CTRL_CORE_PAD_R_GMII0_RXCTL	P2	rgmii0_rxctl		rmii1_txd1	mii0_txd3	vin2a_d6	vin1b_d6	usb3_ulpi_d3					gpio5_27	Driver off
0x1670	CTRL_CORE_PAD_R_GMII0_RXD3	N1	rgmii0_rxd3		rmii1_txd0	mii0_txd2	vin2a_d7	vin1b_d7	usb3_ulpi_d4					gpio5_28	Driver off
0x1674	CTRL_CORE_PAD_R_GMII0_RXD2	P1	rgmii0_rxd2	rmii0_txen		mii0_txen	vin2a_d8		usb3_ulpi_d5					gpio5_29	Driver off
0x1678	CTRL_CORE_PAD_R_GMII0_RXD1	N3	rgmii0_rxd1	rmii0_txd1		mii0_txd1	vin2a_d9		usb3_ulpi_d6					gpio5_30	Driver off
0x167C	CTRL_CORE_PAD_R_GMII0_RXD0	N4	rgmii0_rxd0	rmii0_txd0		mii0_txd0	vin2a_fld0	vin1b_fld1	usb3_ulpi_d7					gpio5_31	Driver off
0x1680	CTRL_CORE_PAD_U_SB1_DRVVBUS	AD3	usb1_drvvbus							timer16				gpio6_12	Driver off
0x1684	CTRL_CORE_PAD_U_SB2_DRVVBUS	AA6	usb2_drvvbus							timer15				gpio6_13	Driver off
0x1688	CTRL_CORE_PAD_GPIO6_14	H21	gpio6_14	mcasp1_axr8	dcan2_tx	uart10_rxd						i2c3_sda	timer1	gpio6_14	Driver off
0x168C	CTRL_CORE_PAD_GPIO6_15	K22	gpio6_15	mcasp1_axr9	dcan2_rx	uart10_txd						i2c3_scl	timer2	gpio6_15	Driver off
0x1690	CTRL_CORE_PAD_GPIO6_16	K23	gpio6_16	mcasp1_axr10							clkout1	timer3		gpio6_16	Driver off
0x1694	CTRL_CORE_PAD_X_REF_CLK0	J25	xref_clk0	mcasp2_axr8	mcasp1_axr4	mcasp1_ahclkx	mcasp5_ahclkx			vin1a_d0		clkout2	timer13	gpio6_17	Driver off
0x1698	CTRL_CORE_PAD_X_REF_CLK1	J24	xref_clk1	mcasp2_axr9	mcasp1_axr5	mcasp2_ahclkx	mcasp6_ahclkx			vin1a_clk0			timer14	gpio6_18	Driver off
0x169C	CTRL_CORE_PAD_X_REF_CLK2	H24	xref_clk2	mcasp2_axr10	mcasp1_axr6	mcasp3_ahclkx	mcasp7_ahclkx						timer15	gpio6_19	Driver off
0x16A0	CTRL_CORE_PAD_X_REF_CLK3	H25	xref_clk3	mcasp2_axr11	mcasp1_axr7	mcasp4_ahclkx	mcasp8_ahclkx					clkout3	timer16	gpio6_20	Driver off
0x16A4	CTRL_CORE_PAD_MCASP1_ACLKX	C16	mcasp1_aclkx							vin1a_fid0			i2c3_sda	gpio7_31	Driver off
0x16A8	CTRL_CORE_PAD_MCASP1_FSX	C17	mcasp1_fsx							vin1a_de0			i2c3_scl	gpio7_30	Driver off
0x16AC	CTRL_CORE_PAD_MCASP1_ACLKR	D16	mcasp1_aclkr	mcasp7_axr2									i2c4_sda	gpio5_0	Driver off
0x16B0	CTRL_CORE_PAD_MCASP1_FSR	D17	mcasp1_fsr	mcasp7_axr3									i2c4_scl	gpio5_1	Driver off
0x16B4	CTRL_CORE_PAD_MCASP1_AXR0	D14	mcasp1_axr0			uart6_rxd				vin1a_vsync0			i2c5_sda	gpio5_2	Driver off
0x16B8	CTRL_CORE_PAD_MCASP1_AXR1	B14	mcasp1_axr1			uart6_txd				vin1a_hsync0			i2c5_scl	gpio5_3	Driver off
0x16BC	CTRL_CORE_PAD_MCASP1_AXR2	C14	mcasp1_axr2	mcasp6_axr2		uart6_ctsn								gpio5_4	Driver off
0x16C0	CTRL_CORE_PAD_MCASP1_AXR3	B15	mcasp1_axr3	mcasp6_axr3		uart6_rtsn								gpio5_5	Driver off
0x16C4	CTRL_CORE_PAD_MCASP1_AXR4	A15	mcasp1_axr4	mcasp4_axr2										gpio5_6	Driver off



**Table 4-27. Pin Multiplexing (continued)**

ADDRESS	REGISTER NAME	BALL NUMBER	MUXMODE FIELD SETTINGS (CTRL_CORE_PAD_*[3:0])													
			0	1	2	3	4*	5	6*	7	8	9	10	14*	15	
0x16C8	CTRL_CORE_PAD_MCASP1_AXR5	A14	mcasp1_axr5	mcasp4_axr3											gpio5_7	Driver off
0x16CC	CTRL_CORE_PAD_MCASP1_AXR6	A17	mcasp1_axr6	mcasp5_axr2											gpio5_8	Driver off
0x16D0	CTRL_CORE_PAD_MCASP1_AXR7	A16	mcasp1_axr7	mcasp5_axr3									timer4	gpio5_9	Driver off	
0x16D4	CTRL_CORE_PAD_MCASP1_AXR8	A18	mcasp1_axr8	mcasp6_axr0		spi3_sclk				vin1a_d15			timer5	gpio5_10	Driver off	
0x16D8	CTRL_CORE_PAD_MCASP1_AXR9	B17	mcasp1_axr9	mcasp6_axr1		spi3_d1				vin1a_d14			timer6	gpio5_11	Driver off	
0x16DC	CTRL_CORE_PAD_MCASP1_AXR10	B16	mcasp1_axr10	mcasp6_aclck	mcasp6_aclkr	spi3_d0				vin1a_d13			timer7	gpio5_12	Driver off	
0x16E0	CTRL_CORE_PAD_MCASP1_AXR11	B18	mcasp1_axr11	mcasp6_fsx	mcasp6_fsr	spi3_cs0				vin1a_d12			timer8	gpio4_17	Driver off	
0x16E4	CTRL_CORE_PAD_MCASP1_AXR12	A19	mcasp1_axr12	mcasp7_axr0		spi3_cs1				vin1a_d11			timer9	gpio4_18	Driver off	
0x16E8	CTRL_CORE_PAD_MCASP1_AXR13	E17	mcasp1_axr13	mcasp7_axr1						vin1a_d10			timer10	gpio6_4	Driver off	
0x16EC	CTRL_CORE_PAD_MCASP1_AXR14	E16	mcasp1_axr14	mcasp7_aclck	mcasp7_aclkr					vin1a_d9			timer11	gpio6_5	Driver off	
0x16F0	CTRL_CORE_PAD_MCASP1_AXR15	F16	mcasp1_axr15	mcasp7_fsx	mcasp7_fsr					vin1a_d8			timer12	gpio6_6	Driver off	
0x16F4	CTRL_CORE_PAD_MCASP2_ACLKX	E19	mcasp2_aclckx							vin1a_d7					Driver off	
0x16F8	CTRL_CORE_PAD_MCASP2_FSX	D19	mcasp2_fsx							vin1a_d6					Driver off	
0x1704	CTRL_CORE_PAD_MCASP2_AXR0	A20	mcasp2_axr0												Driver off	
0x1708	CTRL_CORE_PAD_MCASP2_AXR1	B19	mcasp2_axr1												Driver off	
0x170C	CTRL_CORE_PAD_MCASP2_AXR2	A21	mcasp2_axr2	mcasp3_axr2						vin1a_d5				gpio6_8	Driver off	
0x1710	CTRL_CORE_PAD_MCASP2_AXR3	B21	mcasp2_axr3	mcasp3_axr3						vin1a_d4				gpio6_9	Driver off	
0x1714	CTRL_CORE_PAD_MCASP2_AXR4	B20	mcasp2_axr4	mcasp8_axr0										gpio1_4	Driver off	
0x1718	CTRL_CORE_PAD_MCASP2_AXR5	C19	mcasp2_axr5	mcasp8_axr1										gpio6_7	Driver off	
0x171C	CTRL_CORE_PAD_MCASP2_AXR6	D20	mcasp2_axr6	mcasp8_aclck	mcasp8_aclkr									gpio2_29	Driver off	
0x1720	CTRL_CORE_PAD_MCASP2_AXR7	C20	mcasp2_axr7	mcasp8_fsx	mcasp8_fsr									gpio1_5	Driver off	
0x1724	CTRL_CORE_PAD_MCASP3_ACLKX	A22	mcasp3_aclckx	mcasp3_aclkr	mcasp2_axr12	uart7_rxd				vin1a_d3				gpio5_13	Driver off	
0x1728	CTRL_CORE_PAD_MCASP3_FSX	A23	mcasp3_fsx	mcasp3_fsr	mcasp2_axr13	uart7_txd				vin1a_d2				gpio5_14	Driver off	
0x172C	CTRL_CORE_PAD_MCASP3_AXR0	B22	mcasp3_axr0		mcasp2_axr14	uart7_ctsn	uart5_rxd			vin1a_d1					Driver off	

**Table 4-27. Pin Multiplexing (continued)**

ADDRESS	REGISTER NAME	BALL NUMBER	MUXMODE FIELD SETTINGS (CTRL_CORE_PAD_*[3:0])													
			0	1	2	3	4*	5	6*	7	8	9	10	14*	15	
0x1730	CTRL_CORE_PAD_MCASP3_AXR1	B23	mcasp3_axr1		mcasp2_axr15	uart7_rtsn	uart5_txd				vin1a_d0					Driver off
0x1734	CTRL_CORE_PAD_MCASP4_ACLKX	C23	mcasp4_aclkx	mcasp4_aclkr	spi3_sclk	uart8_rxd	i2c4_sda									Driver off
0x1738	CTRL_CORE_PAD_MCASP4_FSX	B25	mcasp4_fsx	mcasp4_fsr	spi3_d1	uart8_txd	i2c4_scl									Driver off
0x173C	CTRL_CORE_PAD_MCASP4_AXR0	A24	mcasp4_axr0		spi3_d0	uart8_ctsn	uart4_rxd							i2c6_scl		Driver off
0x1740	CTRL_CORE_PAD_MCASP4_AXR1	D23	mcasp4_axr1		spi3_cs0	uart8_rtsn	uart4_txd							i2c6_sda		Driver off
0x1744	CTRL_CORE_PAD_MCASP5_ACLKX	AC3	mcasp5_aclkx	mcasp5_aclkr	spi4_sclk	uart9_rxd	i2c5_sda									Driver off
0x1748	CTRL_CORE_PAD_MCASP5_FSX	U6	mcasp5_fsx	mcasp5_fsr	spi4_d1	uart9_txd	i2c5_scl									Driver off
0x174C	CTRL_CORE_PAD_MCASP5_AXR0	AA5	mcasp5_axr0		spi4_d0	uart9_ctsn	uart3_rxd									Driver off
0x1750	CTRL_CORE_PAD_MCASP5_AXR1	AC4	mcasp5_axr1		spi4_cs0	uart9_rtsn	uart3_txd									Driver off
0x1754	CTRL_CORE_PAD_MMC1_CLK	U3	mmc1_clk											gpio6_21		Driver off
0x1758	CTRL_CORE_PAD_MMC1_CMD	V4	mmc1_cmd											gpio6_22		Driver off
0x175C	CTRL_CORE_PAD_MMC1_DAT0	V3	mmc1_dat0											gpio6_23		Driver off
0x1760	CTRL_CORE_PAD_MMC1_DAT1	V2	mmc1_dat1											gpio6_24		Driver off
0x1764	CTRL_CORE_PAD_MMC1_DAT2	W1	mmc1_dat2											gpio6_25		Driver off
0x1768	CTRL_CORE_PAD_MMC1_DAT3	V1	mmc1_dat3											gpio6_26		Driver off
0x176C	CTRL_CORE_PAD_MMC1_SDCD	U5	mmc1_sdcd			uart6_rxd	i2c4_sda							gpio6_27		Driver off
0x1770	CTRL_CORE_PAD_MMC1_SDWP	V5	mmc1_sdwp			uart6_txd	i2c4_scl							gpio6_28		Driver off
0x1774	CTRL_CORE_PAD_GPIO6_10	Y5	gpio6_10	mdio_mclk	i2c3_sda	usb3_ulpi_d7	vin2b_hsync1					vin1a_clk0	ehrpwm2A	gpio6_10		Driver off
0x1778	CTRL_CORE_PAD_GPIO6_11	Y6	gpio6_11	mdio_d	i2c3_scl	usb3_ulpi_d6	vin2b_vsync1					vin1a_de0	ehrpwm2B	gpio6_11		Driver off
0x177C	CTRL_CORE_PAD_MMC3_CLK	Y2	mmc3_clk			usb3_ulpi_d5	vin2b_d7					vin1a_d7	ehrpwm2_trip zone_input	gpio6_29		Driver off
0x1780	CTRL_CORE_PAD_MMC3_CMD	Y1	mmc3_cmd	spi3_sclk		usb3_ulpi_d4	vin2b_d6					vin1a_d6	eCAP2_in_P WM2_out	gpio6_30		Driver off
0x1784	CTRL_CORE_PAD_MMC3_DAT0	Y4	mmc3_dat0	spi3_d1	uart5_rxd	usb3_ulpi_d3	vin2b_d5					vin1a_d5	eQEP3A_in	gpio6_31		Driver off
0x1788	CTRL_CORE_PAD_MMC3_DAT1	AA2	mmc3_dat1	spi3_d0	uart5_txd	usb3_ulpi_d2	vin2b_d4					vin1a_d4	eQEP3B_in	gpio7_0		Driver off
0x178C	CTRL_CORE_PAD_MMC3_DAT2	AA3	mmc3_dat2	spi3_cs0	uart5_ctsn	usb3_ulpi_d1	vin2b_d3					vin1a_d3	eQEP3_index	gpio7_1		Driver off

**Table 4-27. Pin Multiplexing (continued)**

ADDRESS	REGISTER NAME	BALL NUMBER	MUXMODE FIELD SETTINGS (CTRL_CORE_PAD_*[3:0])													
			0	1	2	3	4*	5	6*	7	8	9	10	14*	15	
0x1790	CTRL_CORE_PAD_MMC3_DAT3	W2	mmc3_dat3	spi3_cs1	uart5_rtsn	usb3_ulpi_d0	vin2b_d2						vin1a_d2	eQEP3_strobe	gpio7_2	Driver off
0x1794	CTRL_CORE_PAD_MMC3_DAT4	Y3	mmc3_dat4	spi4_sclk	uart10_rxd	usb3_ulpi_nxt	vin2b_d1						vin1a_d1	ehrpwm3A	gpio1_22	Driver off
0x1798	CTRL_CORE_PAD_MMC3_DAT5	AA1	mmc3_dat5	spi4_d1	uart10_txd	usb3_ulpi_dir	vin2b_d0						vin1a_d0	ehrpwm3B	gpio1_23	Driver off
0x179C	CTRL_CORE_PAD_MMC3_DAT6	AA4	mmc3_dat6	spi4_d0	uart10_ctsn	usb3_ulpi_stp	vin2b_de1						vin1a_hsync0	ehrpwm3_tripzone_input	gpio1_24	Driver off
0x17A0	CTRL_CORE_PAD_MMC3_DAT7	AB1	mmc3_dat7	spi4_cs0	uart10_rtsn	usb3_ulpi_clk	vin2b_clk1						vin1a_vsync0	eCAP3_in_PWM3_out	gpio1_25	Driver off
0x17A4	CTRL_CORE_PAD_S PI1_SCLK	C24	spi1_sclk												gpio7_7	Driver off
0x17A8	CTRL_CORE_PAD_S PI1_D1	D24	spi1_d1												gpio7_8	Driver off
0x17AC	CTRL_CORE_PAD_S PI1_D0	D25	spi1_d0												gpio7_9	Driver off
0x17B0	CTRL_CORE_PAD_S PI1_CS0	B24	spi1_cs0												gpio7_10	Driver off
0x17B4	CTRL_CORE_PAD_S PI1_CS1	C25	spi1_cs1			spi2_cs1									gpio7_11	Driver off
0x17B8	CTRL_CORE_PAD_S PI1_CS2	E24	spi1_cs2	uart4_rxd	mmc3_sdcd	spi2_cs2	dcan2_tx	mdio_mclk	hdmi1_hpd						gpio7_12	Driver off
0x17BC	CTRL_CORE_PAD_S PI1_CS3	E25	spi1_cs3	uart4_txd	mmc3_sdwp	spi2_cs3	dcan2_rx	mdio_d	hdmi1_cec						gpio7_13	Driver off
0x17C0	CTRL_CORE_PAD_S PI2_SCLK	G25	spi2_sclk	uart3_rxd											gpio7_14	Driver off
0x17C4	CTRL_CORE_PAD_S PI2_D1	F25	spi2_d1	uart3_txd											gpio7_15	Driver off
0x17C8	CTRL_CORE_PAD_S PI2_D0	G24	spi2_d0	uart3_ctsn	uart5_rxd										gpio7_16	Driver off
0x17CC	CTRL_CORE_PAD_S PI2_CS0	F24	spi2_cs0	uart3_rtsn	uart5_txd										gpio7_17	Driver off
0x17D0	CTRL_CORE_PAD_D CAN1_TX	H22	dcan1_tx		uart8_rxd	mmc2_sdcd			hdmi1_hpd						gpio1_14	Driver off
0x17D4	CTRL_CORE_PAD_D CAN1_RX	H23	dcan1_rx		uart8_txd	mmc2_sdwp			hdmi1_cec						gpio1_15	Driver off
0x17E0	CTRL_CORE_PAD_U ART1_RXD	L25	uart1_rxd			mmc4_sdcd									gpio7_22	Driver off
0x17E4	CTRL_CORE_PAD_U ART1_TXD	M25	uart1_txd			mmc4_sdwp									gpio7_23	Driver off
0x17E8	CTRL_CORE_PAD_U ART1_CTSN	L20	uart1_ctsn		uart9_rxd	mmc4_clk									gpio7_24	Driver off
0x17EC	CTRL_CORE_PAD_U ART1_RTSN	M24	uart1_rtsn		uart9_txd	mmc4_cmd									gpio7_25	Driver off
0x17F0	CTRL_CORE_PAD_U ART2_RXD	N23	uart2_rxd	uart3_ctsn	uart3_rctx	mmc4_dat0	uart2_rxd	uart1_dcdn							gpio7_26	Driver off
0x17F4	CTRL_CORE_PAD_U ART2_TXD	N25	uart2_txd	uart3_rtsn	uart3_sd	mmc4_dat1	uart2_txd	uart1_dsrn							gpio7_27	Driver off

Table 4-27. Pin Multiplexing (continued)

ADDRESS	REGISTER NAME	BALL NUMBER	MUXMODE FIELD SETTINGS (CTRL_CORE_PAD_*[3:0])													
			0	1	2	3	4*	5	6*	7	8	9	10	14*	15	
0x17F8	CTRL_CORE_PAD_UART2_CTSN	N22	uart2_ctsn		uart3_rxd	mmc4_dat2	uart10_rxd	uart1_dtrn							gpio1_16	Driver off
0x17FC	CTRL_CORE_PAD_UART2_RTSN	N24	uart2_rtsn	uart3_txd	uart3_irtx	mmc4_dat3	uart10_txd	uart1_rin							gpio1_17	Driver off
0x1800	CTRL_CORE_PAD_I2C1_SDA	G23	i2c1_sda													Driver off
0x1804	CTRL_CORE_PAD_I2C1_SCL	G22	i2c1_scl													Driver off
0x1808	CTRL_CORE_PAD_I2C2_SDA	F23	i2c2_sda	hdmi1_ddc_scl												Driver off
0x180C	CTRL_CORE_PAD_I2C2_SCL	G21	i2c2_scl	hdmi1_ddc_sda												Driver off
0x1818	CTRL_CORE_PAD_WAKEUP0	AC10		dcan1_rx										gpio1_0 sys_nirq2	Driver off	
0x1824	CTRL_CORE_PAD_WAKEUP3	AB10		sys_nirq1										gpio1_3 dcan2_rx	Driver off	
0x1830	CTRL_CORE_PAD_TMS	L21	tms													
0x1834	CTRL_CORE_PAD_TDI	L23	tdi											gpio8_27		
0x1838	CTRL_CORE_PAD_TDO	J20	tdo											gpio8_28		
0x183C	CTRL_CORE_PAD_TCLK	K21	clk													
0x1840	CTRL_CORE_PAD_TRSTN	L22	trstn													
0x1844	CTRL_CORE_PAD_RTCK	K25	rtck											gpio8_29		
0x1848	CTRL_CORE_PAD_EMU0	C21	emu0											gpio8_30		
0x184C	CTRL_CORE_PAD_EMU1	C22	emu1											gpio8_31		
0x185C	CTRL_CORE_PAD_RESETN	K24	resetn													
0x1860	CTRL_CORE_PAD_NMIN_DSP	L24	nmin_dsp													
0x1864	CTRL_CORE_PAD_RSTOUTN	E20	rstoutn													

1. NA in table stands for Not Applicable.

## 4.5 Connections for Unused Pins

This section describes the connection requirements of the unused and reserved balls.

---

### NOTE

The following balls are reserved: K20, L19, G20, T1, T2, U4, T3, U1, U2

These balls must be left unconnected.

---

### NOTE

All unused power supply balls must be supplied with the voltages specified in the [Section 5.4, Recommended Operating Conditions](#), unless alternative tie-off options are included in [Section 4.3, Signal Descriptions](#).

---

**Table 4-28. Unused Balls Specific Connection Requirements**

BALLS	CONNECTION REQUIREMENTS
Y12 / AC11 / L22 / AC10 / AB10 / AD22 / Y24 / V24 / R24	These balls must be connected to GND through an external pull resistor if unused.
K21 / L24 / K24 / G22 / G23 / L21 / G21 / F23 / AE22 / Y25 / V25 / R25	These balls must be connect to the corresponding power supply through an external pull resistor if unused.
F20 (vpp)	This ball must be left unconnected if unused

---

### NOTE

All other unused signal balls with a Pad Configuration register can be left unconnected with their internal pullup or pulldown resistor enabled.

---

### NOTE

All other unused signal balls without a Pad Configuration register can be left unconnected.

---

## 5 Specifications

---

### NOTE

For more information, see Power, Reset, and Clock Management / PRCM Subsystem Environment / External Voltage Inputs or Initialization / Preinitialization / Power Requirements section of the Device TRM.

---

### NOTE

The index number 1 which is part of the EMIF1 signal prefixes (ddr1\_\*) listed in [Table 4-6, EMIF Signal Descriptions](#), column "SIGNAL NAME" not to be confused with DDR1 type of SDRAM memories.

---

### NOTE

Audio Back End (ABE) module is not supported for this family of devices, but "ABE" name is still present in some clock or DPLL names.

---

### CAUTION

All IO Cells are NOT Fail-safe compliant and should not be externally driven in absence of their IO supply.

## 5.1 Absolute Maximum Ratings

over operating free-air temperature range (unless otherwise noted) <sup>(1)</sup>

PARAMETER <sup>(1)</sup>		MIN	MAX	UNIT	
V <sub>SUPPLY</sub> (Steady-State)	Supply Voltage Ranges (Steady-State)	Core (vdd, vdd_dsp)	-0.3	1.5	V
		Analog (vdda_usb1, vdda_usb2, vdda_per, vdda_ddr, vdda_debug, vdda_mpu_abe, vdda_usb3, vdda_csi, vdda_core_gmac, vdda_gpu, vdda_hdmi, vdda_pcie, vdda_video, vdda_osc)	-0.3	2.0	V
		Analog 3.3V (vdda33v_usb1, vdda33v_usb2)	-0.3	3.8	V
		vdds18v, vdds18v_ddr1, vdds_mlbp, vdds_ddr1	-0.3	2.1	V
		vddshv1, vddshv3, vddshv4, vddshv7-11 (1.8V mode)	-0.3	2.1	V
		vddshv1, vddshv3, vddshv4, vddshv7, vddshv9-11 (3.3V mode)	-0.3	3.8	V
		vddshv8 (3.3V mode)	-0.3	3.6	V
V <sub>IO</sub> (Steady-State)	Input and Output Voltage Ranges (Steady-State)	Core I/Os	-0.3	1.5	V
		Analog I/Os (except HDMI)	-0.3	2.0	V
		HDMI I/Os	-0.3	3.5	V
		I/O 1.35V	-0.3	1.65	V
		I/O 1.5V	-0.3	1.8	V
		1.8V I/Os	-0.3	2.1	V
		3.3V I/Os (except those powered by vddshv8)	-0.3	3.8	V
3.3V I/Os (powered by vddshv8)	-0.3	3.6	V		
SR	Maximum slew rate, all supplies		10 <sup>5</sup>	V/s	
V <sub>IO</sub> (Transient Overshoot / Undershoot)	Input and Output Voltage Ranges (Transient Overshoot/Undershoot) Note: valid for up to 20% of the signal period. See <a href="#">Figure 5-1</a> , <i>IO transient voltage ranges</i> .		0.2 × VDD <sup>(4)</sup>	V	
T <sub>J</sub>	Operating junction temperature range	Automotive	-40	+125	°C
T <sub>STG</sub>	Storage temperature range after soldered onto PC Board		-55	+150	°C
Latch-up I-Test	I-test <sup>(5)</sup> , All I/Os (if different levels then one line per level)		-100	100	mA
Latch-up OV-Test	Over-voltage Test <sup>(6)</sup> , All supplies (if different levels then one line per level)		N/A	1.5 × V <sub>supply max</sub>	V

(1) Stresses beyond those listed as absolute maximum ratings may cause permanent damage to the device. These are stress ratings only, and functional operation of the device at these or any other conditions beyond those listed under [Section 5.4](#), *Recommended Operating Conditions*, is not implied. Exposure to absolute maximum rated conditions for extended periods may affect device reliability.

(2) All voltage values are with respect to VSS, unless otherwise noted.

(3) See I/Os supplied by this power pin in [Table 4-1 Pin Attributes](#)

(4) VDD is the voltage on the corresponding power-supply pin(s) for the IO.

(5) Per JEDEC JESD78 at 125°C with specified I/O pin injection current and clamp voltage of 1.5 times maximum recommended I/O voltage and negative 0.5 times maximum recommended I/O voltage.

(6) Per JEDEC JESD78 at 125°C.

(7) The maximum valid input voltage on an IO pin cannot exceed 0.3 volts when the supply powering the IO is turned off. This requirement applies to all the IO pins which are not fail-safe and for all values of IO supply voltage. Special attention should be applied anytime peripheral devices are not powered from the same power sources used to power the respective IO supply. It is important the attached peripheral never sources a voltage outside the valid input voltage range, including power supply ramp-up and ramp-down sequences.

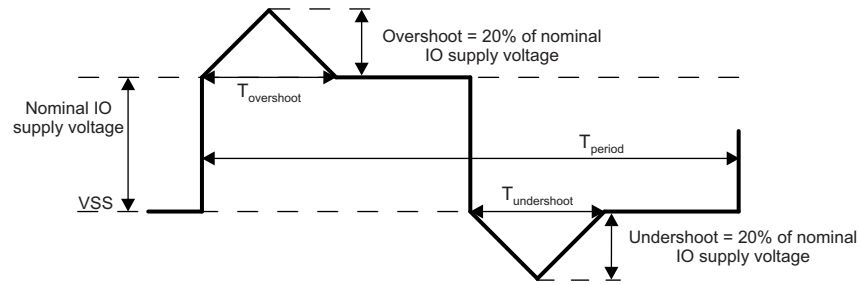

osus\_sprs851

$$(1) T_{\text{overshoot}} + T_{\text{undershoot}} < 20\% \text{ of } T_{\text{period}}$$

**Figure 5-1. IO transient voltage ranges**

## 5.2 ESD Ratings

		VALUE	UNIT	
V <sub>ESD</sub> Electrostatic discharge	Human-Body model (HBM), per AEC Q100-002 <sup>(1)</sup>	±1000	V	
	Charged-device model (CDM), per AEC Q100-011	All pins		±250
		Corner pins (A1, A25, AE1, AE25)		±750

(1) AEC Q100-002 indicates that HBM stressing shall be in accordance with the ANSI/ESDA/JEDEC JS-001 specification.

## 5.3 Power on Hour (POH) Limits

IP	DUTY CYCLE	VOLTAGE DOMAIN	VOLTAGE (V) (MAX)	FREQUENCY (MHz) (MAX)	T <sub>j</sub> (°C)	POH
All	100%	All	All Supported OPPs		Automotive Profile <sup>(4)</sup>	20000

- The information in this section is provided solely for your convenience and does not extend or modify the warranty provided under TI's standard terms and conditions for TI semiconductor products.
- POH is a functional of voltage, temperature and time. Usage at higher voltages and temperatures will result in a reduction in POH to achieve the same reliability performance. For assessment of alternate use cases, contact your local TI representative.
- Unless specified in the table above, all voltage domains and operating conditions are supported in the device at the noted temperatures.
- Automotive profile is defined as 20000 power on hours with junction temperature as follows: 5%@-40°C, 65%@70°C, 20%@110°C, 10%@125°C.

## 5.4 Recommended Operating Conditions

over operating free-air temperature range (unless otherwise noted)

PARAMETER	DESCRIPTION	MIN <sup>(2)</sup>	NOM	MAX DC <sup>(3)</sup>	MAX <sup>(2)</sup>	UNIT
<b>Input Power Supply Voltage Range</b>						
vdd	Core voltage domain supply	See <a href="#">Section 5.5</a>				V
vdd_dsp	DSP voltage domain supply	See <a href="#">Section 5.5</a>				V
vdda_usb1	DPLL_USB and HS USB1 1.8V analog power supply	1.71	1.80	1.836	1.89	V
	Maximum noise (peak-peak)	50				mV <sub>PPmax</sub>
vdda_usb2	HS USB2 1.8V analog power supply	1.71	1.80	1.836	1.89	V
	Maximum noise (peak-peak)	50				mV <sub>PPmax</sub>
vdda33v_usb1 <sup>(5)</sup>	HS USB1 3.3V analog power supply	3.135	3.3	3.366	3.465	V
	Maximum noise (peak-peak)	50				mV <sub>PPmax</sub>
vdda33v_usb2 <sup>(5)</sup>	HS USB2 3.3V analog power supply	3.135	3.3	3.366	3.465	V
	Maximum noise (peak-peak)	50				mV <sub>PPmax</sub>
vdda_per	PER PLL and PER HSDIVIDER analog power supply	1.71	1.80	1.836	1.89	V
	Maximum noise (peak-peak)	50				mV <sub>PPmax</sub>



## Recommended Operating Conditions (continued)

over operating free-air temperature range (unless otherwise noted)

PARAMETER	DESCRIPTION	MIN <sup>(2)</sup>	NOM	MAX DC <sup>(3)</sup>	MAX <sup>(2)</sup>	UNIT	
vdda_dds	DPLL_DDR and DDR HSDIVIDER analog power supply	1.71	1.80	1.836	1.89	V	
	Maximum noise (peak-peak)		50			mV <sub>PPmax</sub>	
vdda_debug	DPLL_DEBUG analog power supply	1.71	1.80	1.836	1.89	V	
	Maximum noise (peak-peak)		50			mV <sub>PPmax</sub>	
vdda_core_gmac	DPLL_CORE and CORE HSDIVIDER analog power supply	1.71	1.80	1.836	1.89	V	
	Maximum noise (peak-peak)		50			mV <sub>PPmax</sub>	
vdda_gpu	DPLL_GPU analog power supply	1.71	1.80	1.836	1.89	V	
	Maximum noise (peak-peak)		50			mV <sub>PPmax</sub>	
vdda_hdmi	PLL_HDMI and HDMI analog power supply	1.71	1.80	1.836	1.89	V	
	Maximum noise (peak-peak)		50			mV <sub>PPmax</sub>	
vdda_pcie	DPLL_PCIE_REF and PCIe analog power supply	1.71	1.80	1.836	1.89	V	
	Maximum noise (peak-peak)		50			mV <sub>PPmax</sub>	
vdda_usb3	DPLL_USB_OTG_SS and USB3.0 RX/TX analog power supply	1.71	1.80	1.836	1.89	V	
	Maximum noise (peak-peak)		50			mV <sub>PPmax</sub>	
vdda_video	DPLL_VIDEO1 analog power supply	1.71	1.80	1.836	1.89	V	
	Maximum noise (peak-peak)		50			mV <sub>PPmax</sub>	
vdds_mlbp	MLBP IO power supply	1.71	1.80		1.89	V	
	Maximum noise (peak-peak)		50			mV <sub>PPmax</sub>	
vdda_mpu_abe	DPLL_MPU analog power supply	1.71	1.80	1.836	1.89	V	
	Maximum noise (peak-peak)		50			mV <sub>PPmax</sub>	
vdda_osc	HFOSC analog power supply	1.71	1.80		1.89	V	
	Maximum noise (peak-peak)		50			mV <sub>PPmax</sub>	
vdda_csi	CSI Interface 1.8v Supply	1.71	1.80	1.836	1.89	V	
	Maximum noise (peak-peak)		50			mV <sub>PPmax</sub>	
vdds18v	1.8V power supply	1.71	1.80	1.836	1.89	V	
	Maximum noise (peak-peak)		50			mV <sub>PPmax</sub>	
vdds18v_dds1	EMIF1 bias power supply	1.71	1.80	1.836	1.89	V	
	Maximum noise (peak-peak)		50			mV <sub>PPmax</sub>	
vdds_dds1	EMIF1 power supply (1.5V for DDR3 mode / 1.35V DDR3L mode)	1.35-V Mode	1.28	1.35	1.337	1.42	V
		1.5-V Mode	1.43	1.50	1.53	1.57	
	Maximum noise (peak-peak)	1.35-V Mode		50			mV <sub>PPmax</sub>
		1.5-V Mode					
vddshv1	Dual Voltage (1.8V or 3.3V) power supply for the VIN2 Power Group pins	1.8-V Mode	1.71	1.80	1.836	1.89	V
		3.3-V Mode	3.135	3.30	3.366	3.465	
	Maximum noise (peak-peak)	1.8-V Mode		50			mV <sub>PPmax</sub>
		3.3-V Mode					

## Recommended Operating Conditions (continued)

over operating free-air temperature range (unless otherwise noted)

PARAMETER	DESCRIPTION		MIN <sup>(2)</sup>	NOM	MAX DC <sup>(3)</sup>	MAX <sup>(2)</sup>	UNIT	
vddshv10	Dual Voltage (1.8V or 3.3V) power supply for the GPMC Power Group pins	1.8-V Mode	1.71	1.80	1.836	1.89	V	
		3.3-V Mode	3.135	3.30	3.366	3.465		
	Maximum noise (peak-peak)	1.8-V Mode	50				mV <sub>PPmax</sub>	
		3.3-V Mode						
vddshv11	Dual Voltage (1.8V or 3.3V) power supply for the MMC2 Power Group pins	1.8-V Mode	1.71	1.80	1.836	1.89	V	
		3.3-V Mode	3.135	3.30	3.366	3.465		
	Maximum noise (peak-peak)	1.8-V Mode	50				mV <sub>PPmax</sub>	
		3.3-V Mode						
vddshv3	Dual Voltage (1.8V or 3.3V) power supply for the GENERAL Power Group pins	1.8-V Mode	1.71	1.80	1.836	1.89	V	
		3.3-V Mode	3.135	3.30	3.366	3.465		
	Maximum noise (peak-peak)	1.8-V Mode	50				mV <sub>PPmax</sub>	
		3.3-V Mode						
vddshv4	Dual Voltage (1.8V or 3.3V) power supply for the MMC4 Power Group pins	1.8-V Mode	1.71	1.80	1.836	1.89	V	
		3.3-V Mode	3.135	3.30	3.366	3.465		
	Maximum noise (peak-peak)	1.8-V Mode	50				mV <sub>PPmax</sub>	
		3.3-V Mode						
vddshv7	Dual Voltage (1.8V or 3.3V) power supply for the WIFI Power Group pins	1.8-V Mode	1.71	1.80	1.836	1.89	V	
		3.3-V Mode	3.135	3.30	3.366	3.465		
	Maximum noise (peak-peak)	1.8-V Mode	50				mV <sub>PPmax</sub>	
		3.3-V Mode						
vddshv8	Dual Voltage (1.8V or 3.3V) power supply for the MMC1 Power Group pins	1.8-V Mode	1.71	1.80	1.836	1.89	V	
		3.3-V Mode	3.135	3.30	3.366	3.465		
	Maximum noise (peak-peak)	1.8-V Mode	50				mV <sub>PPmax</sub>	
		3.3-V Mode						
vddshv9	Dual Voltage (1.8V or 3.3V) power supply for the RGMII Power Group pins	1.8-V Mode	1.71	1.80	1.836	1.89	V	
		3.3-V Mode	3.135	3.30	3.366	3.465		
	Maximum noise (peak-peak)	1.8-V Mode	50				mV <sub>PPmax</sub>	
		3.3-V Mode						
vss	Ground supply			0			V	
vssa_osc0	OSC0 analog ground			0			V	
vssa_osc1	OSC1 analog ground			0			V	
T <sub>J</sub> <sup>(1)</sup>	Operating junction temperature range	Automotive	-40			+125 <sup>(6)</sup>	°C	
ddr1_vref0	Reference Power Supply EMIF1		0.5 x vdds_ddr1					V

(1) Refer to Power on Hours table for limitations.

(2) The voltage at the device ball should never be below the MIN voltage or above the MAX voltage for any amount of time. This requirement includes dynamic voltage events such as AC ripple, voltage transients, voltage dips, etc.

(3) The DC voltage at the device ball should never be above the MAX DC voltage to avoid impact on device reliability and lifetime POH (Power-On-Hours). The MAX DC voltage is defined as the highest allowed DC regulated voltage, without transients, seen at the ball.

(4) Logic functions and parameter values are not assured out of the range specified in the recommended operating conditions.

## Recommended Operating Conditions (continued)

over operating free-air temperature range (unless otherwise noted)

- (5) USB Analog supply also powers digital IO buffers. This supply cannot be tied to VSS if USB is unused since digital IO buffers must be powered during device operation.
- (6) The TSHUT feature of the SoC resets the device by default when one of the on-die temp sensors reports 123 °C. This is intended to protect the device from exceeding 125 °C. Though not recommended, the TSHUT temperature threshold can be modified in software if other mechanisms are in place to avoid exceeding 125 °C. Refer to the device TRM for details on the TSHUT feature.

## 5.5 Operating Performance Points

This section describes the operating conditions of the device. This section also contains the description of each OPP (operating performance point) for processor clocks and device core clocks.

Table 5-1 describes the maximum supported frequency per speed grade for TDA2Ex devices.

**Table 5-1. Speed Grade Maximum Frequency**

DEVICE SPEED	MAXIMUM FREQUENCY (MHz)						
	MPU	DSP	IVA	GPU	IPU	L3	DDR3/DDR3L
TDA2ExxH	800	750	532	425.6	212.8	266	667 (DDR-1333)
TDA2ExxD	500	500	430	425.6	212.8	266	667 (DDR-1333)

(1) N/A stands for Not Applicable.

### 5.5.1 AVS and ABB Requirements

Adaptive Voltage Scaling (AVS) and Adaptive Body Biasing (ABB) are required on most of the vdd\_\* supplies as defined in Table 5-2.

**Table 5-2. AVS and ABB Requirements per vdd\_\* Supply**

SUPPLY	VOLTAGE DOMAIN	AVS REQUIRED?	ABB REQUIRED?
vdd	VD_CORE	Yes, for all OPPs	No
	VD_SGX	Yes, for all OPPs	Yes, for all OPPs
	VD_MPU	Yes, for all OPPs	Yes, for all OPPs
vdd_dsp	VD_DSP	Yes, for all OPPs	Yes, for all OPPs
	VD_IVA	Yes, for all OPPs	Yes, for all OPPs

### 5.5.2 Voltage And Core Clock Specifications

Table 5-3 shows the recommended OPP per voltage domain.

**Table 5-3. Voltage Domains Operating Performance Points**

DOMAIN	CONDITION	OPP_NOM			OPP_HIGH			
		MIN <sup>(2)</sup>	NOM <sup>(1)</sup>	MAX <sup>(2)</sup>	MIN <sup>(2)</sup>	NOM <sup>(1)</sup>	MAX DC <sup>(3)</sup>	MAX <sup>(2)</sup>
VD_CORE (V) <sup>(7)</sup>	BOOT (Before AVS is enabled) <sup>(4)</sup>	1.11	1.15	1.2	Not Applicable			
	After AVS is enabled <sup>(4)</sup>	AVS Voltage <sup>(5)</sup> – 3.5%	AVS Voltage <sup>(5)</sup>	1.2	Not Applicable			
VD_DSP (V) <sup>(8)</sup>	BOOT (Before AVS is enabled) <sup>(4)</sup>	1.02	1.06	1.16	Not Applicable			
	After AVS is enabled <sup>(4)</sup>	AVS Voltage <sup>(5)</sup> – 3.5%	AVS Voltage <sup>(5)</sup>	1.2	AVS Voltage <sup>(5)</sup> – 3.5%	AVS Voltage <sup>(5)</sup>	AVS Voltage <sup>(5)</sup> +2%	AVS Voltage <sup>(5)</sup> + 5%

- (1) In a typical implementation, the power supply should target the NOM voltage.
- (2) The voltage at the device ball should never be below the MIN voltage or above the MAX voltage for any amount of time. This requirement includes dynamic voltage events such as AC ripple, voltage transients, voltage dips, etc.
- (3) The DC voltage at the device ball should never be above the MAX DC voltage to avoid impact on device reliability and lifetime POH (Power-On-Hours). The MAX DC voltage is defined as the highest allowed DC regulated voltage, without transients, seen at the ball.
- (4) For all OPPs, AVS must be enabled to avoid impact on device reliability, lifetime POH (Power-On-Hours), and device power.
- (5) The AVS voltages are device-dependent, voltage domain-dependent, and OPP-dependent. They must be read from the STD\_FUSE\_OPP Registers. For information about STD\_FUSE\_OPP Registers address, please refer to Control Module Section of the TRM. The power supply should be adjustable over the following ranges for each required OPP:
  - OPP\_NOM for DSP: 0.85 V – 1.15 V
  - OPP\_NOM for CORE: 0.85 V - 1.15 V
  - OPP\_HIGH: 1.01 V - 1.25 V
 The AVS voltages will be within the above specified ranges.
- (6) The power supply must be programmed with the AVS voltages for the CORE voltage domain, either just after the ROM boot or at the earliest possible time in the secondary boot loader before there is significant activity seen on these domains.
- (7) The package routes VD\_CORE (vdd) to the VD\_MPU, VD\_SGX, VD\_CORE and VD\_RTC domains on the die.
- (8) The package routes VD\_DSP (vdd\_dsp) to the VD\_DSPEVE and VD\_IVA domains on the die.

Table 5-4 describes the standard processor clocks speed characteristics vs OPP of the device.

**Table 5-4. Supported OPP vs Max Frequency <sup>(2)</sup>**

DESCRIPTION	OPP_NOM	OPP_HIGH
	MAXIMUM FREQUENCY (MHz)	MAXIMUM FREQUENCY (MHz)
<b>VD_CORE</b>		
MPU_CLK	800	N/A
GPU_CLK	425.6	N/A
CORE_IPUx_CLK	212.8	N/A
L3_CLK	266	N/A
DDR3 / DDR3L	667 (DDR-1333)	N/A
<b>VD_DSP</b>		
IVA_GCLK	388.3	532
DSP_CLK	600	750

(1) N/A stands for Not Applicable.

(2) Maximum supported frequency is limited according to the Device Speed Grade (see Table 5-1).

### 5.5.3 Maximum Supported Frequency

Device modules either receive their clock directly from an external clock input, directly from a PLL, or from a PRCM. Table 5-5 lists the clock source options for each module on this device, along with the maximum frequency that module can accept. To ensure proper module functionality, the device PLLs and dividers must be programmed not to exceed the maximum frequencies listed in this table.

**Table 5-5. Maximum Supported Frequency**

MODULE				CLOCK SOURCES		
INSTANCE NAME	INPUT CLOCK NAME	CLOCK TYPE	MAX. CLOCK ALLOWED (MHz)	PRCM CLOCK NAME	PLL / OSC / SOURCE CLOCK NAME	PLL / OSC / SOURCE NAME
AES1	AES1_L3_CLK	Int	266	L4SEC_L3_GICLK	CORE_X2_CLK	DPLL_CORE
AES2	AES2_L3_CLK	Int	266	L4SEC_L3_GICLK	CORE_X2_CLK	DPLL_CORE
BB2D	BB2D_FCLK	Func	354.6	BB2D_GFCLK	BB2D_GFCLK	DPLL_CORE
	BB2D_ICLK	Int	266	DSS_L3_GICLK	CORE_X2_CLK	DPLL_CORE

**Table 5-5. Maximum Supported Frequency (continued)**

MODULE				CLOCK SOURCES		
INSTANCE NAME	INPUT CLOCK NAME	CLOCK TYPE	MAX. CLOCK ALLOWED (MHz)	PRCM CLOCK NAME	PLL / OSC / SOURCE CLOCK NAME	PLL / OSC / SOURCE NAME
COUNTER_32K	COUNTER_32K_FCLK	Func	0.032	FUNC_32K_CLK	SYS_CLK1/610	OSC0
	COUNTER_32K_ICLK	Int	38.4	WKUPAON_GICKL	SYS_CLK1 DPLL_ABE_X2_CLK	OSC0 DPLL_ABE
CTRL_MODULE_BANDGAP	L3INSTR_TS_GCLK	Int	4.8	L3INSTR_TS_GCLK	SYS_CLK1	OSC0
					DPLL_ABE_X2_CLK	DPLL_ABE
CTRL_MODULE_CORE	L4CFG_L4_GICKL	Int	133	L4CFG_L4_GICKL	CORE_X2_CLK	DPLL_CORE
CTRL_MODULE_WKUP	WKUPAON_GICKL	Int	38.4	WKUPAON_GICKL	SYS_CLK1	OSC0
					DPLL_ABE_X2_CLK	DPLL_ABE
DCAN1	DCAN1_FCLK	Func	38.4	DCAN1_SYS_CLK	SYS_CLK1 SYS_CLK2	OSC0 OSC1
	DCAN1_ICLK	Int	266	WKUPAON_GICKL	SYS_CLK1 DPLL_ABE_X2_CLK	OSC0 DPLL_ABE
DCAN2	DCAN2_FCLK	Func	38.4	DCAN2_SYS_CLK	SYS_CLK1	OSC0
	DCAN2_ICLK	Int	266	L4PER2_L3_GICKL	CORE_X2_CLK	DPLL_CORE
DES3DES	DES_CLK_L3	Int	266	L4SEC_L3_GICKL	CORE_X2_CLK	DPLL_CORE
DLL	EMIF_DLL_FCLK	Func		EMIF_DLL_GCLK	EMIF_DLL_GCLK	DPLL_DDR
DLL_AGING	FCLK	Int	38.4 EMIF_DLL_FCLK	L3INSTR_DLL_AGING_GCLK	SYS_CLK1	OSC0
					DPLL_ABE_X2_CLK	DPLL_ABE
DMM	DMM_CLK	Int	266	EMIF_L3_GICKL	CORE_X2_CLK	DPLL_CORE
DPLL_DEBUG	SYSCLK	Int	38.4	EMU_SYS_CLK	SYS_CLK1	OSC0
DSP1	DSP1_FICLK	Int & Func	DSP_CLK	DSP1_GFCLK	DSP_GFCLK	DPLL_DSP

**Table 5-5. Maximum Supported Frequency (continued)**

MODULE				CLOCK SOURCES		
INSTANCE NAME	INPUT CLOCK NAME	CLOCK TYPE	MAX. CLOCK ALLOWED (MHz)	PRCM CLOCK NAME	PLL / OSC / SOURCE CLOCK NAME	PLL / OSC / SOURCE NAME
DSS	DSS_HDMI_CEC_CLK	Func	0.032	HDMI_CEC_GFCLK	SYS_CLK1/610	OSC0
	DSS_HDMI_PHY_CLK	Func	48	HDMI_PHY_GFCLK	FUNC_192M_CLK	DPLL_PER
	DSS_CLK	Func	192	DSS_GFCLK	DSS_CLK	DPLL_PER
	HDMI_CLKINP	Func	38.4	HDMI_DPLL_CLK	SYS_CLK1	OSC0
					SYS_CLK2	OSC1
	DSS_L3_ICLK	Int	266	DSS_L3_GICLK	CORE_X2_CLK	DPLL_CORE
	VIDEO1_CLKINP	Func	38.4	VIDEO1_DPLL_CLK	SYS_CLK1	OSC0
					SYS_CLK2	OSC1
	VIDEO2_CLKINP	Func	38.4	VIDEO2_DPLL_CLK	SYS_CLK1	OSC0
					SYS_CLK2	OSC1
	DPLL_DSI1_A_CLK1	Func	209.3	N/A	HDMI_CLK	DPLL_HDMI
					VIDEO1_CLKOUT1	DPLL_VIDEO1
	DPLL_DSI1_B_CLK1	Func	209.3	N/A	VIDEO1_CLKOUT3	DPLL_VIDEO1
					HDMI_CLK	DPLL_HDMI
DPLL_DSI1_C_CLK1	Func	209.3	N/A	DPLL_ABE_X2_CLK	DPLL_ABE	
				HDMI_CLK	DPLL_HDMI	
DPLL_DSI1_C_CLK1	Func	209.3	N/A	VIDEO1_CLKOUT3	DPLL_VIDEO1	
				HDMI_CLK	DPLL_HDMI	
DPLL_HDMI_CLK1	Func	185.6	N/A	HDMI_CLK	DPLL_HDMI	
DSS DISPC	LCD1_CLK	Func	209.3	N/A	DPLL_DSI1_A_CLK1	See DSS data in the rows above
					DSS_CLK	
	LCD2_CLK	Func	209.3	N/A	DPLL_DSI1_B_CLK1	
					DSS_CLK	
	LCD3_CLK	Func	209.3	N/A	DPLL_DSI1_C_CLK1	
					DSS_CLK	
	F_CLK	Func	209.3	N/A	DPLL_DSI1_A_CLK1	
					DPLL_DSI1_B_CLK1	
					DPLL_DSI1_C_CLK1	
					DSS_CLK	
DPLL_HDMI_CLK1				DPLL_HDMI_CLK1		
EFUSE_CTRL_CUST	ocp_clk	Int	133	CUSTEFUSE_L4_GICLK	CORE_X2_CLK	DPLL_CORE
	sys_clk	Func	38.4	CUSTEFUSE_SYS_GFCLK	SYS_CLK1	OSC0
ELM	ELM_ICLK	Int	266	L4PER_L3_GICLK	CORE_X2_CLK	DPLL_CORE
EMIF_OCP_FW	L3_CLK	Int	266	EMIF_L3_GICLK	CORE_X2_CLK	DPLL_CORE
EMIF_PHY1	EMIF_PHY1_FCLK	Func	DDR	EMIF_PHY_GCLK	EMIF_PHY_GCLK	DPLL_DDR
EMIF1	EMIF1_ICLK	Int	266	EMIF_L3_GICLK	CORE_X2_CLK	DPLL_CORE

**Table 5-5. Maximum Supported Frequency (continued)**

MODULE				CLOCK SOURCES		
INSTANCE NAME	INPUT CLOCK NAME	CLOCK TYPE	MAX. CLOCK ALLOWED (MHz)	PRCM CLOCK NAME	PLL / OSC / SOURCE CLOCK NAME	PLL / OSC / SOURCE NAME
GMAC_SW	CPTS_RFT_CLK	Func	266	GMAC_RFT_CLK	PER_ABE_X1_GFCLK	DPLL_ABE
					VIDEO1_CLK	DPLL_VIDEO1
					HDMI_CLK	DPLL_HDMI
					CORE_X2_CLK	DPLL_CORE
	MAIN_CLK	Int	125	GMAC_MAIN_CLK	GMAC_250M_CLK	DPLL_GMAC
	MHZ_250_CLK	Func	250	GMII_250MHZ_CLK	GMII_250MHZ_CLK	DPLL_GMAC
	MHZ_5_CLK	Func	5	RGMII_5MHZ_CLK	GMAC_RMII_HS_CLK	DPLL_GMAC
	MHZ_50_CLK	Func	50	RMII_50MHZ_CLK	GMAC_RMII_HS_CLK	DPLL_GMAC
RMII1_MHZ_50_CLK	Func	50	RMII_50MHZ_CLK	GMAC_RMII_HS_CLK	DPLL_GMAC	
	RMII2_MHZ_50_CLK	Func	50	RMII_50MHZ_CLK	GMAC_RMII_HS_CLK	DPLL_GMAC
GPIO1	GPIO1_ICLK	Int	38.4	WKUPAON_GICLK	SYS_CLK1	OSC0
					DPLL_ABE_X2_CLK	DPLL_ABE
	GPIO1_DBCLK	Func	0.032	WKUPAON_SYS_GFCCLK	WKUPAON_32K_GFCLK	OSC0
GPIO2	GPIO2_ICLK	Int	266	L4PER_L3_GICLK	CORE_X2_CLK	DPLL_CORE
	GPIO2_DBCLK	Func	0.032	GPIO_GFCLK	FUNC_32K_CLK	OSC0
GPIO3	GPIO3_ICLK	Int	266	L4PER_L3_GICLK	CORE_X2_CLK	DPLL_CORE
	GPIO3_DBCLK	Func	0.032	GPIO_GFCLK	FUNC_32K_CLK	OSC0
GPIO4	GPIO4_ICLK	Int	266	L4PER_L3_GICLK	CORE_X2_CLK	DPLL_CORE
	GPIO4_DBCLK	Func	0.032	GPIO_GFCLK	FUNC_32K_CLK	OSC0
	PIDBCLK	Func	0.032	GPIO_GFCLK		
GPIO5	GPIO5_ICLK	Int	266	L4PER_L3_GICLK	CORE_X2_CLK	DPLL_CORE
	GPIO5_DBCLK	Func	0.032	GPIO_GFCLK	FUNC_32K_CLK	OSC0
	PIDBCLK	Func	0.032	GPIO_GFCLK		
GPIO6	GPIO6_ICLK	Int	266	L4PER_L3_GICLK	CORE_X2_CLK	DPLL_CORE
	GPIO6_DBCLK	Func	0.032	GPIO_GFCLK	FUNC_32K_CLK	OSC0
	PIDBCLK	Func	0.032	GPIO_GFCLK		
GPIO7	GPIO7_ICLK	Int	266	L4PER_L3_GICLK	CORE_X2_CLK	DPLL_CORE
	GPIO7_DBCLK	Func	0.032	GPIO_GFCLK	FUNC_32K_CLK	OSC0
	PIDBCLK	Func	0.032	GPIO_GFCLK		
GPIO8	GPIO8_ICLK	Int	266	L4PER_L3_GICLK	CORE_X2_CLK	DPLL_CORE
	GPIO8_DBCLK	Func	0.032	GPIO_GFCLK	FUNC_32K_CLK	OSC0
	PIDBCLK	Func	0.032	GPIO_GFCLK		
GPMC	GPMC_FCLK	Int	266	L3MAIN1_L3_GICLK	CORE_X2_CLK	DPLL_CORE

**Table 5-5. Maximum Supported Frequency (continued)**

MODULE				CLOCK SOURCES		
INSTANCE NAME	INPUT CLOCK NAME	CLOCK TYPE	MAX. CLOCK ALLOWED (MHz)	PRCM CLOCK NAME	PLL / OSC / SOURCE CLOCK NAME	PLL / OSC / SOURCE NAME
GPU	GPU_FCLK1	Func	GPU_CLK	GPU_CORE_GCLK	CORE_GPU_CLK	DPLL_CORE
					PER_GPU_CLK	DPLL_PER
					GPU_GCLK	DPLL_GPU
	GPU_FCLK2	Func	GPU_CLK	GPU_HYD_GCLK	CORE_GPU_CLK	DPLL_CORE
					PER_GPU_CLK	DPLL_PER
					GPU_GCLK	DPLL_GPU
GPU_ICLK	Int	266	GPU_L3_GICLK	CORE_X2_CLK	DPLL_CORE	
HDMI PHY	DSS_HDMI_PHY_CLK	Func	38.4	HDMI_PHY_GFCLK	FUNC_192M_CLK	DPLL_PER
I2C1	I2C1_ICLK	Int	266	L4PER_L3_GICLK	CORE_X2_CLK	DPLL_CORE
	I2C1_FCLK	Func	96	PER_96M_GFCLK	FUNC_192M_CLK	DPLL_PER
I2C2	I2C2_ICLK	Int	266	L4PER_L3_GICLK	CORE_X2_CLK	DPLL_CORE
	I2C2_FCLK	Func	96	PER_96M_GFCLK	FUNC_192M_CLK	DPLL_PER
I2C3	I2C3_ICLK	Int	266	L4PER_L3_GICLK	CORE_X2_CLK	DPLL_CORE
	I2C3_FCLK	Func	96	PER_96M_GFCLK	FUNC_192M_CLK	DPLL_PER
I2C4	I2C4_ICLK	Int	266	L4PER_L3_GICLK	CORE_X2_CLK	DPLL_CORE
	I2C4_FCLK	Func	96	PER_96M_GFCLK	FUNC_192M_CLK	DPLL_PER
I2C5	I2C5_ICLK	Int	266	IPU_L3_GICLK	CORE_X2_CLK	DPLL_CORE
	I2C5_FCLK	Func	96	IPU_96M_GFCLK	FUNC_192M_CLK	DPLL_PER
I2C6	I2C6_ICLK	Int	266	L4PER2_L3_GICLK	CORE_X2_CLK	DPLL_CORE
	I2C6_FCLK	Func	96	IPU_96M_GFCLK	FUNC_192M_CLK	DPLL_PER
IEEE1500_2_OC P	PI_L3CLK	Int & Func	266	L3INIT_L3_GICLK	CORE_X2_CLK	DPLL_CORE
IPU1	IPU1_GFCLK	Int & Func	425.6	IPU1_GFCLK	DPLL_ABE_X2_CLK	DPLL_ABE
					CORE_IPU_ISS_B OOST_CLK	DPLL_CORE
IPU2	IPU2_GFCLK	Int & Func	425.6	IPU2_GFCLK	CORE_IPU_ISS_B OOST_CLK	DPLL_CORE
IVA	IVA_GCLK	Int	IVA_GCLK	IVA_GCLK	IVA_GFCLK	DPLL_IVA
KBD	KBD_FCLK	Func	0.032	WKUPAON_SYS_GFC LK	WKUPAON_32K_ GFCLK	OSC0
	PICLKKBD	Func	0.032	WKUPAON_SYS_GFC LK		OSC0
	KBD_ICLK	Int	38.4	WKUPAON_GICLK	SYS_CLK1	OSC0
	PICLKOCP	Int	38.4	WKUPAON_GICLK	DPLL_ABE_X2_CLK	DPLL_ABE
L3_INSTR	L3_CLK	Int	L3_CLK	L3INSTR_L3_GICLK	CORE_X2_CLK	DPLL_CORE
L3_MAIN	L3_CLK1	Int	L3_CLK	L3MAIN1_L3_GICLK	CORE_X2_CLK	DPLL_CORE
	L3_CLK2	Int	L3_CLK	L3INSTR_L3_GICLK	CORE_X2_CLK	DPLL_CORE
L4_CFG	L4_CFG_CLK	Int	133	L4CFG_L3_GICLK	CORE_X2_CLK	DPLL_CORE
L4_PER1	L4_PER1_CLK	Int	133	L4PER_L3_GICLK	CORE_X2_CLK	DPLL_CORE
L4_PER2	L4_PER2_CLK	Int	133	L4PER2_L3_GICLK	CORE_X2_CLK	DPLL_CORE
L4_PER3	L4_PER3_CLK	Int	133	L4PER3_L3_GICLK	CORE_X2_CLK	DPLL_CORE
L4_WKUP	L4_WKUP_CLK	Int	38.4	WKUPAON_GICLK	SYS_CLK1	OSC0
					DPLL_ABE_X2_CLK	DPLL_ABE
MAILBOX1	MAILBOX1_FLCK	Int	266	L4CFG_L3_GICLK	CORE_X2_CLK	DPLL_CORE



**Table 5-5. Maximum Supported Frequency (continued)**

MODULE				CLOCK SOURCES		
INSTANCE NAME	INPUT CLOCK NAME	CLOCK TYPE	MAX. CLOCK ALLOWED (MHz)	PRCM CLOCK NAME	PLL / OSC / SOURCE CLOCK NAME	PLL / OSC / SOURCE NAME
MAILBOX2	MAILBOX2_FLCK	Int	266	L4CFG_L3_GICLK	CORE_X2_CLK	DPLL_CORE
MAILBOX3	MAILBOX3_FLCK	Int	266	L4CFG_L3_GICLK	CORE_X2_CLK	DPLL_CORE
MAILBOX4	MAILBOX4_FLCK	Int	266	L4CFG_L3_GICLK	CORE_X2_CLK	DPLL_CORE
MAILBOX5	MAILBOX5_FLCK	Int	266	L4CFG_L3_GICLK	CORE_X2_CLK	DPLL_CORE
MAILBOX6	MAILBOX6_FLCK	Int	266	L4CFG_L3_GICLK	CORE_X2_CLK	DPLL_CORE
MAILBOX7	MAILBOX7_FLCK	Int	266	L4CFG_L3_GICLK	CORE_X2_CLK	DPLL_CORE
MAILBOX8	MAILBOX8_FLCK	Int	266	L4CFG_L3_GICLK	CORE_X2_CLK	DPLL_CORE
MAILBOX9	MAILBOX9_FLCK	Int	266	L4CFG_L3_GICLK	CORE_X2_CLK	DPLL_CORE
MAILBOX10	MAILBOX10_FLCK	Int	266	L4CFG_L3_GICLK	CORE_X2_CLK	DPLL_CORE
MAILBOX11	MAILBOX11_FLCK	Int	266	L4CFG_L3_GICLK	CORE_X2_CLK	DPLL_CORE
MAILBOX12	MAILBOX12_FLCK	Int	266	L4CFG_L3_GICLK	CORE_X2_CLK	DPLL_CORE
MAILBOX13	MAILBOX13_FLCK	Int	266	L4CFG_L3_GICLK	CORE_X2_CLK	DPLL_CORE

**Table 5-5. Maximum Supported Frequency (continued)**

MODULE				CLOCK SOURCES		
INSTANCE NAME	INPUT CLOCK NAME	CLOCK TYPE	MAX. CLOCK ALLOWED (MHz)	PRCM CLOCK NAME	PLL / OSC / SOURCE CLOCK NAME	PLL / OSC / SOURCE NAME
MCASP1	MCASP1_AHCLKR	Func	100	MCASP1_AHCLKR	ABE_24M_GFCLK	DPLL_ABE
					ABE_SYS_CLK	OSC0
					FUNC_24M_GFCLK	DPLL_PER
					ATL_CLK0	Module ATL
					ATL_CLK1	Module ATL
					ATL_CLK2	Module ATL
					ATL_CLK3	Module ATL
					SYS_CLK2	OSC1
					XREF_CLK0	XREF_CLK0
					XREF_CLK1	XREF_CLK1
					XREF_CLK2	XREF_CLK2
					XREF_CLK3	XREF_CLK3
					MLB_CLK	Module MLB
					MLBP_CLK	Module MLB
MCASP1	MCASP1_AHCLKX	Func	100	MCASP1_AHCLKX	ABE_24M_GFCLK	DPLL_ABE
					ABE_SYS_CLK	OSC0
					FUNC_24M_GFCLK	DPLL_PER
					ATL_CLK0	Module ATL
					ATL_CLK1	Module ATL
					ATL_CLK2	Module ATL
					ATL_CLK3	Module ATL
					SYS_CLK2	OSC1
					XREF_CLK0	XREF_CLK0
					XREF_CLK1	XREF_CLK1
					XREF_CLK2	XREF_CLK2
					XREF_CLK3	XREF_CLK3
					MLB_CLK	Module MLB
					MLBP_CLK	Module MLB
MCASP1	MCASP1_FCLK	Func	192	MCASP1_AUX_GFCLK	PER_ABE_X1_GFCLK	DPLL_ABE
					VIDEO1_CLK	DPLL_VIDEO1
					HDMI_CLK	DPLL_HDMI
					MCASP1_ICLK	Int

**Table 5-5. Maximum Supported Frequency (continued)**

MODULE				CLOCK SOURCES		
INSTANCE NAME	INPUT CLOCK NAME	CLOCK TYPE	MAX. CLOCK ALLOWED (MHz)	PRCM CLOCK NAME	PLL / OSC / SOURCE CLOCK NAME	PLL / OSC / SOURCE NAME
MCASP2	MCASP2_AHCLKR	Func	100	MCASP2_AHCLKR	ABE_24M_GFCLK	DPLL_ABE
					ABE_SYS_CLK	OSC0
					FUNC_24M_GFCLK	DPLL_PER
					ATL_CLK0	Module ATL
					ATL_CLK1	Module ATL
					ATL_CLK2	Module ATL
					ATL_CLK3	Module ATL
					SYS_CLK2	OSC1
					XREF_CLK0	XREF_CLK0
					XREF_CLK1	XREF_CLK1
					XREF_CLK2	XREF_CLK2
					XREF_CLK3	XREF_CLK3
					MLB_CLK	Module MLB
					MLBP_CLK	Module MLB
MCASP2	MCASP2_AHCLKX	Func	100	MCASP2_AHCLKX	ABE_24M_GFCLK	DPLL_ABE
					ABE_SYS_CLK	OSC0
					FUNC_24M_GFCLK	DPLL_PER
					ATL_CLK0	Module ATL
					ATL_CLK1	Module ATL
					ATL_CLK2	Module ATL
					ATL_CLK3	Module ATL
					SYS_CLK2	OSC1
					XREF_CLK0	XREF_CLK0
					XREF_CLK1	XREF_CLK1
					XREF_CLK2	XREF_CLK2
					XREF_CLK3	XREF_CLK3
					MLB_CLK	Module MLB
					MLBP_CLK	Module MLB
MCASP2	MCASP2_FCLK	Func	192	MCASP2_AUX_GFCLK	PER_ABE_X1_GFCLK	DPLL_ABE
					VIDEO1_CLK	DPLL_VIDEO1
					HDMI_CLK	DPLL_HDMI
					MCASP2_ICLK	Int

**Table 5-5. Maximum Supported Frequency (continued)**

MODULE				CLOCK SOURCES		
INSTANCE NAME	INPUT CLOCK NAME	CLOCK TYPE	MAX. CLOCK ALLOWED (MHz)	PRCM CLOCK NAME	PLL / OSC / SOURCE CLOCK NAME	PLL / OSC / SOURCE NAME
MCASP3	MCASP3_AHCLKX	Func	100	MCASP3_AHCLKX	ABE_24M_GFCLK	DPLL_ABE
					ABE_SYS_CLK	OSC0
					FUNC_24M_GFCLK	DPLL_PER
					ATL_CLK0	Module ATL
					ATL_CLK1	Module ATL
					ATL_CLK2	Module ATL
					ATL_CLK3	Module ATL
					SYS_CLK2	OSC1
					XREF_CLK0	XREF_CLK0
					XREF_CLK1	XREF_CLK1
					XREF_CLK2	XREF_CLK2
					XREF_CLK3	XREF_CLK3
					MLB_CLK	Module MLB
					MLBP_CLK	Module MLB
					MCASP3	MCASP3_FCLK
VIDEO1_CLK	DPLL_ABE					
HDMI_CLK	DPLL_HDMI					
MCASP3	MCASP3_ICLK	Int	266	L4PER2_L3_GICLK	CORE_X2_CLK	DPLL_CORE
MCASP4	MCASP4_AHCLKX	Func	100	MCASP4_AHCLKX	ABE_24M_GFCLK	DPLL_ABE
					ABE_SYS_CLK	OSC0
					FUNC_24M_GFCLK	DPLL_PER
					ATL_CLK0	Module ATL
					ATL_CLK1	Module ATL
					ATL_CLK2	Module ATL
					ATL_CLK3	Module ATL
					SYS_CLK2	OSC1
					XREF_CLK0	XREF_CLK0
					XREF_CLK1	XREF_CLK1
					XREF_CLK2	XREF_CLK2
					XREF_CLK3	XREF_CLK3
					MLB_CLK	Module MLB
					MLBP_CLK	Module MLB
					MCASP4	MCASP4_FCLK
VIDEO1_CLK	DPLL_ABE					
HDMI_CLK	DPLL_HDMI					
MCASP4	MCASP4_ICLK	Int	266	L4PER2_L3_GICLK	CORE_X2_CLK	DPLL_CORE

**Table 5-5. Maximum Supported Frequency (continued)**

MODULE				CLOCK SOURCES		
INSTANCE NAME	INPUT CLOCK NAME	CLOCK TYPE	MAX. CLOCK ALLOWED (MHz)	PRCM CLOCK NAME	PLL / OSC / SOURCE CLOCK NAME	PLL / OSC / SOURCE NAME
MCASP5	MCASP5_AHCLKX	Func	100	MCASP5_AHCLKX	ABE_24M_GFCLK	DPLL_ABE
					ABE_SYS_CLK	OSC0
					FUNC_24M_GFCLK	DPLL_PER
					ATL_CLK0	Module ATL
					ATL_CLK1	Module ATL
					ATL_CLK2	Module ATL
					ATL_CLK3	Module ATL
					SYS_CLK2	OSC1
					XREF_CLK0	XREF_CLK0
					XREF_CLK1	XREF_CLK1
					XREF_CLK2	XREF_CLK2
					XREF_CLK3	XREF_CLK3
					MLB_CLK	Module MLB
					MLBP_CLK	Module MLB
					MCASP5_FCLK	MCASP5_FCLK
VIDEO1_CLK	DPLL_ABE					
HDMI_CLK	DPLL_HDMI					
MCASP5_ICLK	MCASP5_ICLK	Int	266	L4PER2_L3_GICLK	CORE_X2_CLK	DPLL_CORE
MCASP6	MCASP6_AHCLKX	Func	100	MCASP6_AHCLKX	ABE_24M_GFCLK	DPLL_ABE
					FUNC_24M_GFCLK	DPLL_PER
					ATL_CLK0	Module ATL
					ATL_CLK1	Module ATL
					ATL_CLK2	Module ATL
					ATL_CLK3	Module ATL
					MLB_CLK	Module MLB
					MLBP_CLK	Module MLB
					ABE_SYS_CLK	OSC0
					SYS_CLK2	OSC1
					XREF_CLK0	XREF_CLK0
					XREF_CLK1	XREF_CLK1
					XREF_CLK2	XREF_CLK2
					XREF_CLK3	XREF_CLK3
					MCASP6_FCLK	MCASP6_FCLK
VIDEO1_CLK	DPLL_ABE					
HDMI_CLK	DPLL_HDMI					
MCASP6_ICLK	MCASP6_ICLK	Int	266	L4PER2_L3_GICLK	CORE_X2_CLK	DPLL_CORE

**Table 5-5. Maximum Supported Frequency (continued)**

MODULE				CLOCK SOURCES		
INSTANCE NAME	INPUT CLOCK NAME	CLOCK TYPE	MAX. CLOCK ALLOWED (MHz)	PRCM CLOCK NAME	PLL / OSC / SOURCE CLOCK NAME	PLL / OSC / SOURCE NAME
MCASP7	MCASP7_AHCLKX	Func	100	MCASP7_AHCLKX	ABE_24M_GFCLK	DPLL_ABE
					ABE_SYS_CLK	OSC0
					FUNC_24M_GFCLK	DPLL_PER
					ATL_CLK0	Module ATL
					ATL_CLK1	Module ATL
					ATL_CLK2	Module ATL
					ATL_CLK3	Module ATL
					SYS_CLK2	OSC1
					XREF_CLK0	XREF_CLK0
					XREF_CLK1	XREF_CLK1
					XREF_CLK2	XREF_CLK2
					XREF_CLK3	XREF_CLK3
					MLB_CLK	Module MLB
					MLBP_CLK	Module MLB
					MCASP7_FCLK	MCASP7_FCLK
VIDEO1_CLK	DPLL_ABE					
HDMI_CLK	DPLL_HDMI					
MCASP7_ICLK	MCASP7_ICLK	Int	266	L4PER2_L3_GICLK	CORE_X2_CLK	DPLL_CORE
MCASP8	MCASP8_AHCLKX	Func	100	MCASP8_AHCLKX	ABE_24M_GFCLK	DPLL_ABE
					ABE_SYS_CLK	OSC0
					FUNC_24M_GFCLK	DPLL_PER
					ATL_CLK0	Module ATL
					ATL_CLK1	Module ATL
					ATL_CLK2	Module ATL
					ATL_CLK3	Module ATL
					SYS_CLK2	OSC1
					XREF_CLK0	XREF_CLK0
					XREF_CLK1	XREF_CLK1
					XREF_CLK2	XREF_CLK2
					XREF_CLK3	XREF_CLK3
					MLB_CLK	Module MLB
					MLBP_CLK	Module MLB
					MCASP8_FCLK	MCASP8_FCLK
VIDEO1_CLK	DPLL_ABE					
HDMI_CLK	DPLL_HDMI					
MCASP8_ICLK	MCASP8_ICLK	Int	266	L4PER2_L3_GICLK	CORE_X2_CLK	DPLL_CORE
MCSP11	SPI1_ICLK	Int	266	L4PER_L3_GICLK	CORE_X2_CLK	DPLL_CORE
	SPI1_FCLK	Func	48	PER_48M_GFCLK	PER_48M_GFCLK	DPLL_PER
MCSP12	SPI2_ICLK	Int	266	L4PER_L3_GICLK	CORE_X2_CLK	DPLL_CORE
	SPI2_FCLK	Func	48	PER_48M_GFCLK	PER_48M_GFCLK	DPLL_PER
MCSP13	SPI3_ICLK	Int	266	L4PER_L3_GICLK	CORE_X2_CLK	DPLL_CORE
	SPI3_FCLK	Func	48	PER_48M_GFCLK	PER_48M_GFCLK	DPLL_PER

**Table 5-5. Maximum Supported Frequency (continued)**

MODULE				CLOCK SOURCES		
INSTANCE NAME	INPUT CLOCK NAME	CLOCK TYPE	MAX. CLOCK ALLOWED (MHz)	PRCM CLOCK NAME	PLL / OSC / SOURCE CLOCK NAME	PLL / OSC / SOURCE NAME
MCSP14	SPI4_ICLK	Int	266	L4PER_L3_GICLK	CORE_X2_CLK	DPLL_CORE
	SPI4_FCLK	Func	48	PER_48M_GFCLK	PER_48M_GFCLK	DPLL_PER
MLB_SS	MLB_L3_ICLK	Int	266	MLB_SHB_L3_GICLK	CORE_X2_CLK	DPLL_CORE
	MLB_L4_ICLK	Int	133	MLB_SPB_L4_GICLK	CORE_X2_CLK	DPLL_CORE
	MLB_FCLK	Func	266	MLB_SYS_L3_GFCLK	CORE_X2_CLK	DPLL_CORE
CSI2_0	CTRLCLK	Int & Func	96	LVDSRX_96M_GFCLK	FUNC_192M_CLK	DPLL_PER
	CAL_FCLK	Int & Func	266	CAL_GICLK	CORE_ISS_MAIN_CLK	DPLL_CORE
					L3_ICLK	CM_CORE_AON
MMC1	MMC1_CLK_32K	Func	0.032	L3INIT_32K_GFCLK	FUNC_32K_CLK	OSC0
	MMC1_FCLK	Func	192	MMC1_GFCLK	FUNC_192M_CLK	DPLL_PER
			128		FUNC_256M_CLK	DPLL_PER
	MMC1_ICLK1	Int	266	L3INIT_L3_GICLK	CORE_X2_CLK	DPLL_CORE
	MMC1_ICLK2	Int	133	L3INIT_L4_GICLK	CORE_X2_CLK	DPLL_CORE
MMC2	MMC2_CLK_32K	Func	0.032	L3INIT_32K_GFCLK	FUNC_32K_CLK	OSC0
	MMC2_FCLK	Func	192	MMC2_GFCLK	FUNC_192M_CLK	DPLL_PER
			128		FUNC_256M_CLK	DPLL_PER
	MMC2_ICLK1	Int	266	L3INIT_L3_GICLK	CORE_X2_CLK	DPLL_CORE
	MMC2_ICLK2	Int	133	L3INIT_L4_GICLK	CORE_X2_CLK	DPLL_CORE
MMC3	MMC3_ICLK	Int	266	L4PER_L3_GICLK	CORE_X2_CLK	DPLL_CORE
	MMC3_CLK_32K	Func	0.032	L4PER_32K_GFCLK	FUNC_32K_CLK	OSC0
	MMC3_FCLK	Func	48	MMC3_GFCLK	FUNC_192M_CLK	DPLL_PER
192						
MMC4	MMC4_ICLK	Int	266	L4PER_L3_GICLK	CORE_X2_CLK	DPLL_CORE
	MMC4_CLK_32K	Func	0.032	L4PER_32K_GFCLK	FUNC_32K_CLK	OSC0
	MMC4_FCLK	Func	48	MMC4_GFCLK	FUNC_192M_CLK	DPLL_PER
192						
MMU_EDMA	MMU1_CLK	Int	266	L3MAIN1_L3_GICLK	CORE_X2_CLK	DPLL_CORE
MMU_PCIESS	MMU2_CLK	Int	266	L3MAIN1_L3_GICLK	CORE_X2_CLK	DPLL_CORE
MPU	MPU_CLK	Int & Func	MPU_CLK	MPU_GCLK	MPU_GCLK	DPLL_MPU
MPU_EMU_DBG	FCLK	Int	38.4	EMU_SYS_CLK	SYS_CLK1	OSC0
					MPU_GCLK	DPLL_MPU
OCMC_RAM1	OCMC1_L3_CLK	Int	266	L3MAIN1_L3_GICLK	CORE_X2_CLK	DPLL_CORE
OCMC_ROM	OCMC_L3_CLK	Int	266	L3MAIN1_L3_GICLK	CORE_X2_CLK	DPLL_CORE
OCP_WP_NOC	PICLKOCPL3	Int	266	L3INSTR_L3_GICLK	CORE_X2_CLK	DPLL_CORE
OCP2SCP1	L4CFG1_ADAPTER_CLKIN	Int	133	L3INIT_L4_GICLK	CORE_X2_CLK	DPLL_CORE
OCP2SCP2	L4CFG2_ADAPTER_CLKIN	Int	133	L4CFG_L4_GICLK	CORE_X2_CLK	DPLL_CORE
OCP2SCP3	L4CFG3_ADAPTER_CLKIN	Int	133	L3INIT_L4_GICLK	CORE_X2_CLK	DPLL_CORE

**Table 5-5. Maximum Supported Frequency (continued)**

MODULE				CLOCK SOURCES		
INSTANCE NAME	INPUT CLOCK NAME	CLOCK TYPE	MAX. CLOCK ALLOWED (MHz)	PRCM CLOCK NAME	PLL / OSC / SOURCE CLOCK NAME	PLL / OSC / SOURCE NAME
PCle_SS1	PCIE1_PHY_WKUP_CLK	Func	0.032	PCIE_32K_GFCLK	FUNC_32K_CLK	DPLL_CORE
	PCle_SS1_FICLK	Int	266	PCIE_L3_GICLK	CORE_X2_CLK	
	PCIEPHY_CLK	Func	2500	PCIE_PHY_GCLK	PCIE_PHY_GCLK	APLL_PCIE
	PCIEPHY_CLK_DIV	Func	1250	PCIE_PHY_DIV_GCLK	PCIE_PHY_DIV_GCLK	APLL_PCIE
	PCIE1_REF_CLKIN	Func	34.3	PCIE_REF_GFCLK	CORE_USB_OTG_SS_LFPS_TX_CLK	DPLL_CORE
	PCIE1_PWR_CLK	Func	38.4	PCIE_SYS_GFCLK	SYS_CLK1	OSC0
PCle_SS2	PCIE2_PHY_WKUP_CLK	Func	0.032	PCIE_32K_GFCLK	FUNC_32K_CLK	DPLL_CORE
	PCle_SS2_FICLK	Func	266	PCIE_L3_GICLK	CORE_X2_CLK	
	PCIEPHY_CLK	Func	2500	PCIE_PHY_GCLK	PCIE_PHY_GCLK	APLL_PCIE
	PCIEPHY_CLK_DIV	Func	1250	PCIE_PHY_DIV_GCLK	PCIE_PHY_DIV_GCLK	APLL_PCIE
	PCIE2_REF_CLKIN	Func	34.3	PCIE_REF_GFCLK	CORE_USB_OTG_SS_LFPS_TX_CLK	DPLL_CORE
	PCIE2_PWR_CLK	Func	38.4	PCIE_SYS_GFCLK	SYS_CLK1	OSC0
PRCM_MPU	32K_CLK	Func	0.032	FUNC_32K_CLK	SYS_CLK1/610	OSC0
	SYS_CLK	Func	38.4	WKUPAON_ICLK	SYS_CLK1	OSC0
					DPLL_ABE_X2_CLK	DPLL_ABE
PWMSS1	PWMSS1_GICLK	Int & Func	266	L4PER2_L3_GICLK	CORE_X2_CLK	DPLL_CORE
PWMSS2	PWMSS2_GICLK	Int & Func	266	L4PER2_L3_GICLK	CORE_X2_CLK	DPLL_CORE
PWMSS3	PWMSS3_GICLK	Int & Func	266	L4PER2_L3_GICLK	CORE_X2_CLK	DPLL_CORE
QSPI	QSPI_ICLK	Int	266	L4PER2_L3_GICLK	CORE_X2_CLK	DPLL_CORE
	QSPI_FCLK	Func	128	QSPI_GFCLK	FUNC_256M_CLK	DPLL_PER
		PER_QSPI_CLK			DPLL_PER	
RNG	RNG_ICLK	Int	266	L4SEC_L3_GICLK	CORE_X2_CLK	DPLL_CORE
SAR_ROM	PRCM_ROM_CLOCK	Int	266	L4CFG_L3_GICLK	CORE_X2_CLK	DPLL_CORE
SDMA	SDMA_FCLK	Int & Func	266	DMA_L3_GICLK	CORE_X2_CLK	DPLL_CORE
SHA2MD51	SHAM_1_CLK	Int	266	L4SEC_L3_GICLK	CORE_X2_CLK	DPLL_CORE
SHA2MD52	SHAM_2_CLK	Int	266	L4SEC_L3_GICLK	CORE_X2_CLK	DPLL_CORE
SL2	IVA_GCLK	Int	<a href="#">IVA_GCLK</a>	IVA_GCLK	IVA_GFCLK	DPLL_IVA
SMARTREFLEX_CORE	MCLK	Int	133	COREAON_L4_GICLK	CORE_X2_CLK	DPLL_CORE
	SYSCLK	Func	38.4	WKUPAON_ICLK	SYS_CLK1	OSC0
					DPLL_ABE_X2_CLK	DPLL_ABE
SMARTREFLEX_DSP	MCLK	Int	133	COREAON_L4_GICLK	CORE_X2_CLK	DPLL_CORE
	SYSCLK	Func	38.4	WKUPAON_ICLK	SYS_CLK1	OSC0
					DPLL_ABE_X2_CLK	DPLL_ABE



**Table 5-5. Maximum Supported Frequency (continued)**

MODULE				CLOCK SOURCES		
INSTANCE NAME	INPUT CLOCK NAME	CLOCK TYPE	MAX. CLOCK ALLOWED (MHz)	PRCM CLOCK NAME	PLL / OSC / SOURCE CLOCK NAME	PLL / OSC / SOURCE NAME
SMARTREFLEX_GPU	MCLK	Int	133	COREAON_L4_GICLK	CORE_X2_CLK	DPLL_CORE
	SYSCLK	Func	38.4	WKUPAON_ICLK	SYS_CLK1 DPLL_ABE_X2_CLK	OSC0 DPLL_ABE
SMARTREFLEX_IVAHD	MCLK	Int	133	COREAON_L4_GICLK	CORE_X2_CLK	DPLL_CORE
	SYSCLK	Func	38.4	WKUPAON_ICLK	SYS_CLK1 DPLL_ABE_X2_CLK	OSC0 DPLL_ABE
SMARTREFLEX_MPU	MCLK	Int	133	COREAON_L4_GICLK	CORE_X2_CLK	DPLL_CORE
	SYSCLK	Func	38.4	WKUPAON_ICLK	SYS_CLK1 DPLL_ABE_X2_CLK	OSC0 DPLL_ABE
SPINLOCK	SPINLOCK_ICLK	Int	266	L4CFG_L3_GICLK	CORE_X2_CLK	DPLL_CORE
TIMER1	TIMER1_ICLK	Int	38.4	WKUPAON_GICLK	SYS_CLK1	OSC0
					DPLL_ABE_X2_CLK	DPLL_ABE
	TIMER1_FCLK	Func	100	TIMER1_GFCLK	SYS_CLK1	OSC0
					FUNC_32K_CLK	OSC0
					SYS_CLK2	OSC1
					XREF_CLK0	XREF_CLK0
					XREF_CLK1	XREF_CLK1
					XREF_CLK2	XREF_CLK2
					XREF_CLK3	XREF_CLK3
					DPLL_ABE_X2_CLK	DPLL_ABE
VIDEO1_CLK	DPLL_VIDEO1					
HDMI_CLK	DPLL_HDMI					
TIMER2	TIMER2_ICLK	Int	266	L4PER_L3_GICLK	CORE_X2_CLK	DPLL_CORE
	TIMER2_FCLK	Func	100	TIMER2_GFCLK	SYS_CLK1	OSC0
					FUNC_32K_CLK	OSC0
					SYS_CLK2	OSC1
					XREF_CLK0	XREF_CLK0
					XREF_CLK1	XREF_CLK1
					XREF_CLK2	XREF_CLK2
					XREF_CLK3	XREF_CLK3
					DPLL_ABE_X2_CLK	DPLL_ABE
					VIDEO1_CLK	DPLL_VIDEO1
HDMI_CLK	DPLL_HDMI					

**Table 5-5. Maximum Supported Frequency (continued)**

MODULE				CLOCK SOURCES		
INSTANCE NAME	INPUT CLOCK NAME	CLOCK TYPE	MAX. CLOCK ALLOWED (MHz)	PRCM CLOCK NAME	PLL / OSC / SOURCE CLOCK NAME	PLL / OSC / SOURCE NAME
TIMER3	TIMER3_ICLK	Int	266	L4PER_L3_GICLK	CORE_X2_CLK	DPLL_CORE
	TIMER3_FCLK	Func	100	TIMER3_GFCLK	SYS_CLK1	OSC0
					FUNC_32K_CLK	OSC0
					SYS_CLK2	OSC1
					XREF_CLK0	XREF_CLK0
					XREF_CLK1	XREF_CLK1
					XREF_CLK2	XREF_CLK2
					XREF_CLK3	XREF_CLK3
					DPLL_ABE_X2_CLK	DPLL_ABE
VIDEO1_CLK	DPLL_VIDEO1					
HDMI_CLK	DPLL_HDMI					
TIMER4	TIMER4_ICLK	Int	266	L4PER_L3_GICLK	CORE_X2_CLK	DPLL_CORE
	TIMER4_FCLK	Func	100	TIMER4_GFCLK	SYS_CLK1	OSC0
					FUNC_32K_CLK	OSC0
					SYS_CLK2	OSC1
					XREF_CLK0	XREF_CLK0
					XREF_CLK1	XREF_CLK1
					XREF_CLK2	XREF_CLK2
					XREF_CLK3	XREF_CLK3
					DPLL_ABE_X2_CLK	DPLL_ABE
VIDEO1_CLK	DPLL_VIDEO1					
HDMI_CLK	DPLL_HDMI					
TIMER5	TIMER5_ICLK	Int	266	IPU_L3_GICLK	CORE_X2_CLK	DPLL_CORE
	TIMER5_FCLK	Func	100	TIMER5_GFCLK	SYS_CLK1	OSC0
					FUNC_32K_CLK	OSC0
					SYS_CLK2	OSC1
					XREF_CLK0	XREF_CLK0
					XREF_CLK1	XREF_CLK1
					XREF_CLK2	XREF_CLK2
					XREF_CLK3	XREF_CLK3
					DPLL_ABE_X2_CLK	DPLL_ABE
VIDEO1_CLK	DPLL_VIDEO1					
HDMI_CLK	DPLL_HDMI					
CLKOUTMUX[0]	CLKOUTMUX[0]					

**Table 5-5. Maximum Supported Frequency (continued)**

MODULE				CLOCK SOURCES		
INSTANCE NAME	INPUT CLOCK NAME	CLOCK TYPE	MAX. CLOCK ALLOWED (MHz)	PRCM CLOCK NAME	PLL / OSC / SOURCE CLOCK NAME	PLL / OSC / SOURCE NAME
TIMER6	TIMER6_ICLK	Int	266	IPU_L3_GICLK	CORE_X2_CLK	DPLL_CORE
	TIMER6_FCLK	Func	100	TIMER6_GFCLK	SYS_CLK1	OSC0
					FUNC_32K_CLK	OSC0
					SYS_CLK2	OSC1
					XREF_CLK0	XREF_CLK0
					XREF_CLK1	XREF_CLK1
					XREF_CLK2	XREF_CLK2
					XREF_CLK3	XREF_CLK3
					DPLL_ABE_X2_CLK	DPLL_ABE
					VIDEO1_CLK	DPLL_VIDEO1
HDMI_CLK	DPLL_HDMI					
CLKOUTMUX[0]	CLKOUTMUX[0]					
TIMER7	TIMER7_ICLK	Int	266	IPU_L3_GICLK	CORE_X2_CLK	DPLL_CORE
	TIMER7_FCLK	Func	100	TIMER7_GFCLK	SYS_CLK1	OSC0
					FUNC_32K_CLK	OSC0
					SYS_CLK2	OSC1
					XREF_CLK0	XREF_CLK0
					XREF_CLK1	XREF_CLK1
					XREF_CLK2	XREF_CLK2
					XREF_CLK3	XREF_CLK3
					DPLL_ABE_X2_CLK	DPLL_ABE
					VIDEO1_CLK	DPLL_VIDEO1
HDMI_CLK	DPLL_HDMI					
CLKOUTMUX[0]	CLKOUTMUX[0]					
TIMER8	TIMER8_ICLK	Int	266	IPU_L3_GICLK	CORE_X2_CLK	DPLL_CORE
	TIMER8_FCLK	Func	100	TIMER8_GFCLK	SYS_CLK1	OSC0
					FUNC_32K_CLK	OSC0
					SYS_CLK2	OSC1
					XREF_CLK0	XREF_CLK0
					XREF_CLK1	XREF_CLK1
					XREF_CLK2	XREF_CLK2
					XREF_CLK3	XREF_CLK3
					DPLL_ABE_X2_CLK	DPLL_ABE
					VIDEO1_CLK	DPLL_VIDEO1
HDMI_CLK	DPLL_HDMI					
CLKOUTMUX[0]	CLKOUTMUX[0]					

**Table 5-5. Maximum Supported Frequency (continued)**

MODULE				CLOCK SOURCES		
INSTANCE NAME	INPUT CLOCK NAME	CLOCK TYPE	MAX. CLOCK ALLOWED (MHz)	PRCM CLOCK NAME	PLL / OSC / SOURCE CLOCK NAME	PLL / OSC / SOURCE NAME
TIMER9	TIMER9_ICLK	Int	266	L4PER_L3_GICLK	CORE_X2_CLK	DPLL_CORE
	TIMER9_FCLK	Func	100	TIMER9_GFCLK	SYS_CLK1	OSC0
					FUNC_32K_CLK	OSC0
					SYS_CLK2	OSC1
					XREF_CLK0	XREF_CLK0
					XREF_CLK1	XREF_CLK1
					XREF_CLK2	XREF_CLK2
					XREF_CLK3	XREF_CLK3
					DPLL_ABE_X2_CLK	DPLL_ABE
VIDEO1_CLK	DPLL_VIDEO1					
HDMI_CLK	DPLL_HDMI					
TIMER10	TIMER10_ICLK	Int	266	L4PER_L3_GICLK	CORE_X2_CLK	DPLL_CORE
	TIMER10_FCLK	Func	100	TIMER10_GFCLK	SYS_CLK1	OSC0
					FUNC_32K_CLK	OSC0
					SYS_CLK2	OSC1
					XREF_CLK0	XREF_CLK0
					XREF_CLK1	XREF_CLK1
					XREF_CLK2	XREF_CLK2
					XREF_CLK3	XREF_CLK3
					DPLL_ABE_X2_CLK	DPLL_ABE
VIDEO1_CLK	DPLL_VIDEO1					
HDMI_CLK	DPLL_HDMI					
TIMER11	TIMER11_ICLK	Int	266	L4PER_L3_GICLK	CORE_X2_CLK	DPLL_CORE
	TIMER11_FCLK	Func	100	TIMER11_GFCLK	SYS_CLK1	OSC0
					FUNC_32K_CLK	OSC0
					SYS_CLK2	OSC1
					XREF_CLK0	XREF_CLK0
					XREF_CLK1	XREF_CLK1
					XREF_CLK2	XREF_CLK2
					XREF_CLK3	XREF_CLK3
					DPLL_ABE_X2_CLK	DPLL_ABE
VIDEO1_CLK	DPLL_VIDEO1					
HDMI_CLK	DPLL_HDMI					
TIMER12	TIMER12_ICLK	Int	38.4	WKUPAON_GICLK	SYS_CLK1	OSC0
	TIMER12_FCLK	Func	0.032	OSC_32K_CLK	DPLL_ABE_X2_CLK	DPLL_ABE
					RC_CLK	RC oscillator

**Table 5-5. Maximum Supported Frequency (continued)**

MODULE				CLOCK SOURCES		
INSTANCE NAME	INPUT CLOCK NAME	CLOCK TYPE	MAX. CLOCK ALLOWED (MHz)	PRCM CLOCK NAME	PLL / OSC / SOURCE CLOCK NAME	PLL / OSC / SOURCE NAME
TIMER13	TIMER13_ICLK	Int	266	L4PER3_L3_GICLK	CORE_X2_CLK	DPLL_CORE
	TIMER13_FCLK	Func	100	TIMER13_GFCLK	SYS_CLK1	OSC0
					FUNC_32K_CLK	OSC0
					SYS_CLK2	OSC1
					XREF_CLK0	XREF_CLK0
					XREF_CLK1	XREF_CLK1
					XREF_CLK2	XREF_CLK2
					XREF_CLK3	XREF_CLK3
					DPLL_ABE_X2_CLK	DPLL_ABE
VIDEO1_CLK	DPLL_VIDEO1					
HDMI_CLK	DPLL_HDMI					
TIMER14	TIMER14_ICLK	Int	266	L4PER3_L3_GICLK	CORE_X2_CLK	DPLL_CORE
	TIMER14_FCLK	Func	100	TIMER14_GFCLK	SYS_CLK1	OSC0
					FUNC_32K_CLK	OSC0
					SYS_CLK2	OSC1
					XREF_CLK0	XREF_CLK0
					XREF_CLK1	XREF_CLK1
					XREF_CLK2	XREF_CLK2
					XREF_CLK3	XREF_CLK3
					DPLL_ABE_X2_CLK	DPLL_ABE
VIDEO1_CLK	DPLL_VIDEO1					
HDMI_CLK	DPLL_HDMI					
TIMER15	TIMER15_ICLK	Int	266	L4PER3_L3_GICLK	CORE_X2_CLK	DPLL_CORE
	TIMER15_FCLK	Func	100	TIMER15_GFCLK	SYS_CLK1	OSC0
					FUNC_32K_CLK	OSC0
					SYS_CLK2	OSC1
					XREF_CLK0	XREF_CLK0
					XREF_CLK1	XREF_CLK1
					XREF_CLK2	XREF_CLK2
					XREF_CLK3	XREF_CLK3
					DPLL_ABE_X2_CLK	DPLL_ABE
VIDEO1_CLK	DPLL_VIDEO1					
HDMI_CLK	DPLL_HDMI					

**Table 5-5. Maximum Supported Frequency (continued)**

MODULE				CLOCK SOURCES		
INSTANCE NAME	INPUT CLOCK NAME	CLOCK TYPE	MAX. CLOCK ALLOWED (MHz)	PRCM CLOCK NAME	PLL / OSC / SOURCE CLOCK NAME	PLL / OSC / SOURCE NAME
TIMER16	TIMER16_ICLK	Int	266	L4PER3_L3_GICLK	CORE_X2_CLK	DPLL_CORE
	TIMER16_FCLK	Func	100	TIMER16_GFCLK	SYS_CLK1	OSC0
					FUNC_32K_CLK	OSC0
					SYS_CLK2	OSC1
					XREF_CLK0	XREF_CLK0
					XREF_CLK1	XREF_CLK1
					XREF_CLK2	XREF_CLK2
					XREF_CLK3	XREF_CLK3
					DPLL_ABE_X2_CLK	DPLL_ABE
VIDEO1_CLK	DPLL_VIDEO1					
HDMI_CLK	DPLL_HDMI					
TPCC	TPCC_GCLK	Int	266	L3MAIN1_L3_GICLK	CORE_X2_CLK	DPLL_CORE
TPTC1	TPTC0_GCLK	Int	266	L3MAIN1_L3_GICLK	CORE_X2_CLK	DPLL_CORE
TPTC2	TPTC1_GCLK	Int	266	L3MAIN1_L3_GICLK	CORE_X2_CLK	DPLL_CORE
UART1	UART1_FCLK	Func	48	UART1_GFCLK	FUNC_192M_CLK	DPLL_PER
	UART1_ICLK	Int	266	L4PER_L3_GICLK	CORE_X2_CLK	DPLL_CORE
UART2	UART2_FCLK	Func	48	UART2_GFCLK	FUNC_192M_CLK	DPLL_PER
	UART2_ICLK	Int	266	L4PER_L3_GICLK	CORE_X2_CLK	DPLL_CORE
UART3	UART3_FCLK	Func	48	UART3_GFCLK	FUNC_192M_CLK	DPLL_PER
	UART3_ICLK	Int	266	L4PER_L3_GICLK	CORE_X2_CLK	DPLL_CORE
UART4	UART4_FCLK	Func	48	UART4_GFCLK	FUNC_192M_CLK	DPLL_PER
	UART4_ICLK	Int	266	L4PER_L3_GICLK	CORE_X2_CLK	DPLL_CORE
UART5	UART5_FCLK	Func	48	UART5_GFCLK	FUNC_192M_CLK	DPLL_PER
	UART5_ICLK	Int	266	L4PER_L3_GICLK	CORE_X2_CLK	DPLL_CORE
UART6	UART6_FCLK	Func	48	UART6_GFCLK	FUNC_192M_CLK	DPLL_PER
	UART6_ICLK	Int	266	IPU_L3_GICLK	CORE_X2_CLK	DPLL_CORE
UART7	UART7_FCLK	Func	48	UART7_GFCLK	FUNC_192M_CLK	DPLL_PER
	UART7_ICLK	Int	266	L4PER2_L3_GICLK	CORE_X2_CLK	DPLL_CORE
UART8	UART8_FCLK	Func	48	UART8_GFCLK	FUNC_192M_CLK	DPLL_PER
	UART8_ICLK	Int	266	L4PER2_L3_GICLK	CORE_X2_CLK	DPLL_CORE
UART9	UART9_FCLK	Func	48	UART9_GFCLK	FUNC_192M_CLK	DPLL_PER
	UART9_ICLK	Int	266	L4PER2_L3_GICLK	CORE_X2_CLK	DPLL_CORE
UART10	UART10_FCLK	Func	48	UART10_GFCLK	FUNC_192M_CLK	DPLL_PER
	UART10_ICLK	Int	38.4	WKUPAON_GICLK	SYS_CLK1	OSC0
					DPLL_ABE_X2_CLK	DPLL_ABE
USB1	USB1_MICLK	Int	266	L3INIT_L3_GICLK	CORE_X2_CLK	DPLL_CORE
	USB3PHY_REF_CLK	Func	34.3	USB_LFPS_TX_GFCLK	CORE_USB_OTG_SS_LFPS_TX_CLK	DPLL_CORE
	USB2PHY1_TREF_CLK	Func	38.4	USB_OTG_SS_REF_CLK	SYS_CLK1	OSC0
	USB2PHY1_REF_CLK	Func	960	L3INIT_960M_GFCLK	L3INIT_960_GFCLK	DPLL_USB

**Table 5-5. Maximum Supported Frequency (continued)**

MODULE				CLOCK SOURCES		
INSTANCE NAME	INPUT CLOCK NAME	CLOCK TYPE	MAX. CLOCK ALLOWED (MHz)	PRCM CLOCK NAME	PLL / OSC / SOURCE CLOCK NAME	PLL / OSC / SOURCE NAME
USB2	USB2_MICLK	Int	266	L3INIT_L3_GICLK	CORE_X2_CLK	DPLL_CORE
	USB2PHY2_TREF_CLK	Func	38.4	USB_OTG_SS_REF_CLK	SYS_CLK1	OSC0
	USB2PHY2_REF_CLK	Func	960	L3INIT_960M_GFCLK	L3INIT_960_GFCLK	DPLL_USB
USB3	USB3_MICLK	Int	266	L3INIT_L3_GICLK	CORE_X2_CLK	DPLL_CORE
	USB3PHY_PWRS_CLK	Func	38.4	USB_OTG_SS_REF_CLK	SYS_CLK1	OSC0
USB_PHY1_COR_E	USB2PHY1_WKUP_CLK	Func	0.032	COREAON_32K_GFCCLK	SYS_CLK1/610	OSC0
USB_PHY2_COR_E	USB2PHY2_WKUP_CLK	Func	0.032	COREAON_32K_GFCCLK	SYS_CLK1/610	OSC0
USB_PHY3_COR_E	USB3PHY_WKUP_CLK	Func	0.032	COREAON_32K_GFCCLK	SYS_CLK1/610	OSC0
VIP1	L3_CLK_PROC_CLK	Int & Func	266	VIP1_GCLK	CORE_X2_CLK	DPLL_CORE
					CORE_ISS_MAIN_CLK	DPLL_CORE
VPE	L3_CLK_PROC_CLK	Int & Func	300	VPE_GCLK	CORE_ISS_MAIN_CLK	DPLL_CORE
					VIDEO1_CLKOUT4	DPLL_VIDEO1
WD_TIMER1	PIOCPCLK	Int	38.4	WKUPAON_GICLK	SYS_CLK1	OSC0
					DPLL_ABE_X2_CLK	DPLL_ABE
	PITIMERCLK	Func	0.032	OSC_32K_CLK	RC_CLK	RC oscillator
WD_TIMER2	WD_TIMER2_ICLK	Int	38.4	WKUPAON_GICLK	SYS_CLK1	OSC0
					DPLL_ABE_X2_CLK	DPLL_ABE
	WD_TIMER2_FCLK	Func	0.032	WKUPAON_SYS_GFCCLK	WKUPAON_32K_GFCLK	

## 5.6 Power Consumption Summary

### NOTE

Maximum power consumption for this SoC depends on the specific use conditions for the end system. Contact your TI representative for assistance in estimating maximum power consumption for the end system use case.

## 5.7 Electrical Characteristics

### NOTE

The interfaces or signals described in [Section 5.7](#) through [Section 5.7.3](#) correspond to the interfaces or signals available in multiplexing mode 0 (Function 1).

All interfaces or signals multiplexed on the balls described in these tables have the same DC electrical characteristics, unless multiplexing involves a PHY/GPIO combination in which case different DC electrical characteristics are specified for the different multiplexing modes (Functions).

**Table 5-6. LVCMOS DDR DC Electrical Characteristics**

over operating free-air temperature range (unless otherwise noted)

PARAMETER		MIN	NOM	MAX	UNIT
<b>Signal Names in MUXMODE 0 (Single-Ended Signals):</b> ddr1_d[31:0], ddr1_a[15:0], ddr1_dqm[3:0], ddr1_ba[2:0], ddr1_csn0, ddr1_cke, ddr1_odt0, ddr1_casn, ddr1_rasn, ddr1_wen, ddr1_rst					
<b>Balls:</b> AA23 / AC24 / AB24 / AD24 / AB23 / AC23 / AD23 / AE24 / AA24 / W25 / Y23 / AD25 / AC25 / AB25 / AA25 / W24 / W23 / U25 / U24 / W21 / T22 / U22 / U23 / T21 / T23 / T25 / T24 / P21 / N21 / P22 / P23 / P24 / AC18 / AE19 / AD19 / AB19 / AD20 / AE20 / AA18 / AA20 / Y21 / AC20 / AA21 / AC21 / AC22 / AC15 / AB15 / AC16 / AE23 / W22 / U21 / P25 / AE16 / AA16 / AB16 / AC19 / AB18 / AD18 / AD16 / AD17 / AE18 / AE17					
<b>Driver Mode</b>					
V <sub>OH</sub>	High-level output threshold (I <sub>OH</sub> = 0.1 mA)	0.9 × V <sub>DD5</sub>			V
V <sub>OL</sub>	Low-level output threshold (I <sub>OL</sub> = 0.1 mA)	0.1 × V <sub>DD5</sub>			V
C <sub>PAD</sub>	Pad capacitance (including package capacitance)	3			pF
Z <sub>O</sub>	Output impedance (drive strength)	I[2:0] = 000 (Imp80)	80		Ω
		I[2:0] = 001 (Imp60)	60		
		I[2:0] = 010 (Imp48)	48		
		I[2:0] = 011 (Imp40)	40		
		I[2:0] = 100 (Imp34)	34		
<b>Single-Ended Receiver Mode</b>					
V <sub>IH</sub>	High-level input threshold	DDR3/DDR3L	VREF+0.1	V <sub>DD5</sub> +0.2	V
V <sub>IL</sub>	Low-level input threshold	DDR3/DDR3L	-0.2	VREF-0.1	V
V <sub>CM</sub>	Input common-mode voltage		VREF -10%v <sub>dds</sub>	VREF+ 10%v <sub>dds</sub>	V
C <sub>PAD</sub>	Pad capacitance (including package capacitance)	3			pF
<b>Signal Names in MUXMODE 0 (Differential Signals):</b> ddr1_ck, ddr1_nck, ddr1_dqs[3:0], ddr1_dqsn[3:0]					
<b>Bottom Balls:</b> AD21 / AE21 / AD22 / AE22 / Y24 / Y25 / V24 / V25 / R24 / R25					
<b>Driver Mode</b>					
V <sub>OH</sub>	High-level output threshold (I <sub>OH</sub> = 0.1 mA)	0.9 × V <sub>DD5</sub>			V
V <sub>OL</sub>	Low-level output threshold (I <sub>OL</sub> = 0.1 mA)	0.1 × V <sub>DD5</sub>			V
C <sub>PAD</sub>	Pad capacitance (including package capacitance)	3			pF
Z <sub>O</sub>	Output impedance (drive strength)	I[2:0] = 000 (Imp80)	80		Ω
		I[2:0] = 001 (Imp60)	60		
		I[2:0] = 010 (Imp48)	48		
		I[2:0] = 011 (Imp40)	40		
		I[2:0] = 100 (Imp34)	34		
<b>Single-Ended Receiver Mode</b>					
V <sub>IH</sub>	High-level input threshold	DDR3/DDR3L	VREF+0.1	V <sub>DD5</sub> +0.2	V
V <sub>IL</sub>	Low-level input threshold	DDR3/DDR3L	-0.2	VREF-0.1	V
V <sub>CM</sub>	Input common-mode voltage		VREF -10%v <sub>dds</sub>	VREF+ 10%v <sub>dds</sub>	V
C <sub>PAD</sub>	Pad capacitance (including package capacitance)	3			pF
<b>Differential Receiver Mode</b>					
V <sub>SWING</sub>	Input voltage swing	DDR3/DDR3L	0.2	v <sub>dds</sub> +0.4	V
V <sub>CM</sub>	Input common-mode voltage		VREF -10%v <sub>dds</sub>	VREF+ 10%v <sub>dds</sub>	V



**Table 5-6. LVCMOS DDR DC Electrical Characteristics (continued)**

over operating free-air temperature range (unless otherwise noted)

PARAMETER		MIN	NOM	MAX	UNIT
C <sub>PAD</sub>	Pad capacitance (including package capacitance)			3	pF

- (1) VDD5 stands for corresponding power supply (that is, vdds\_dds1). For more information on the power supply name and the corresponding ball, see [Table 4-1](#), POWER [10] column.
- (2) VREF in this table stands for corresponding Reference Power Supply (that is, ddr1\_vref0). For more information on the power supply name and the corresponding ball, see [Table 4-1](#), POWER [10] column.
- (3) For more information on the I/O cell configurations (i[2:0], sr[1:0]), see the Chapter *Control Module* of the Device TRM.

**Table 5-7. Dual Voltage LVCMOS I<sup>2</sup>C DC Electrical Characteristics**

over operating free-air temperature range (unless otherwise noted)

PARAMETER		MIN	NOM	MAX	UNIT
<b>Signal Names in MUXMODE 0:</b> i2c1_scl; i2c1_sda; i2c2_scl; i2c2_sda					
<b>Balls:</b> G22 / G23 / G21 / F23					
<b>I<sup>2</sup>C Standard Mode – 1.8 V</b>					
V <sub>IH</sub>	Input high-level threshold	0.7 × VDD5			V
V <sub>IL</sub>	Input low-level threshold		0.3 × VDD5		V
V <sub>hys</sub>	Hysteresis	0.1 × VDD5			V
I <sub>IN</sub>	Input current at each I/O pin with an input voltage between 0.1 × VDD5 to 0.9 × VDD5			12	μA
I <sub>OZ</sub>	I <sub>OZ</sub> (I <sub>PAD</sub> Current) for BIDI cell. This current is contributed by the tristated driver leakage + input current of the Rx + weak pullup/pulldown leakage. PAD is swept from 0 to VDD5 and the Max(I <sub>PAD</sub> ) is measured and is reported as I <sub>OZ</sub>			12	μA
C <sub>IN</sub>	Input capacitance			10	pF
V <sub>OL3</sub>	Output low-level threshold open-drain at 3-mA sink current		0.2 × VDD5		V
I <sub>OLmin</sub>	Low-level output current @V <sub>OL</sub> =0.2 × VDD5	3			mA
t <sub>OF</sub>	Output fall time from V <sub>IHmin</sub> to V <sub>ILmax</sub> with a bus capacitance CB from 5 pF to 400 pF			250	ns
<b>I<sup>2</sup>C Fast Mode – 1.8 V</b>					
V <sub>IH</sub>	Input high-level threshold	0.7 × VDD5			V
V <sub>IL</sub>	Input low-level threshold		0.3 × VDD5		V
V <sub>hys</sub>	Hysteresis	0.1 × VDD5			V
I <sub>IN</sub>	Input current at each I/O pin with an input voltage between 0.1 × VDD5 to 0.9 × VDD5			12	μA
I <sub>OZ</sub>	I <sub>OZ</sub> (I <sub>PAD</sub> Current) for BIDI cell. This current is contributed by the tristated driver leakage + input current of the Rx + weak pullup/pulldown leakage. PAD is swept from 0 to VDD5 and the Max(I <sub>PAD</sub> ) is measured and is reported as I <sub>OZ</sub>			12	μA
C <sub>IN</sub>	Input capacitance			10	pF
V <sub>OL3</sub>	Output low-level threshold open-drain at 3-mA sink current		0.2 × VDD5		V
I <sub>OLmin</sub>	Low-level output current @V <sub>OL</sub> =0.2 × VDD5	3			mA
t <sub>OF</sub>	Output fall time from V <sub>IHmin</sub> to V <sub>ILmax</sub> with a bus capacitance CB from 10 pF to 400 pF	20+0.1 × C <sub>b</sub>		250	ns
<b>I<sup>2</sup>C Standard Mode – 3.3 V</b>					
V <sub>IH</sub>	Input high-level threshold	0.7 × VDD5			V
V <sub>IL</sub>	Input low-level threshold		0.3 × VDD5		V
V <sub>hys</sub>	Hysteresis	0.05 × VDD5			V
I <sub>IN</sub>	Input current at each I/O pin with an input voltage between 0.1 × VDD5 to 0.9 × VDD5	31		80	μA

**Table 5-7. Dual Voltage LVCMOS I<sup>2</sup>C DC Electrical Characteristics (continued)**

over operating free-air temperature range (unless otherwise noted)

PARAMETER		MIN	NOM	MAX	UNIT
I <sub>OZ</sub>	I <sub>OZ</sub> (I <sub>PAD</sub> Current) for BIDI cell. This current is contributed by the tristated driver leakage + input current of the Rx + weak pullup/pulldown leakage. PAD is swept from 0 to V <sub>DD5</sub> and the Max(I <sub>(PAD)</sub> ) is measured and is reported as I <sub>OZ</sub>	31		80	μA
C <sub>IN</sub>	Input capacitance			10	pF
V <sub>OL3</sub>	Output low-level threshold open-drain at 3-mA sink current			0.4	V
I <sub>OLmin</sub>	Low-level output current @V <sub>OL</sub> =0.4V	3			mA
I <sub>OLmin</sub>	Low-level output current @V <sub>OL</sub> =0.6V for full drive load (400pF/400KHz)	6			mA
t <sub>OF</sub>	Output fall time from V <sub>IHmin</sub> to V <sub>ILmax</sub> with a bus capacitance CB from 5 pF to 400 pF			250	ns
<b>I<sup>2</sup>C Fast Mode – 3.3 V</b>					
V <sub>IH</sub>	Input high-level threshold	0.7 × V <sub>DD5</sub>			V
V <sub>IL</sub>	Input low-level threshold	0.3 × V <sub>DD5</sub>			V
V <sub>hys</sub>	Hysteresis	0.05 × V <sub>DD5</sub>			V
I <sub>IN</sub>	Input current at each I/O pin with an input voltage between 0.1 × V <sub>DD5</sub> to 0.9 × V <sub>DD5</sub>	31		80	μA
I <sub>OZ</sub>	I <sub>OZ</sub> (I <sub>PAD</sub> Current) for BIDI cell. This current is contributed by the tristated driver leakage + input current of the Rx + weak pullup/pulldown leakage. PAD is swept from 0 to V <sub>DD5</sub> and the Max(I <sub>(PAD)</sub> ) is measured and is reported as I <sub>OZ</sub>	31		80	μA
C <sub>IN</sub>	Input capacitance			10	pF
V <sub>OL3</sub>	Output low-level threshold open-drain at 3-mA sink current			0.4	V
I <sub>OLmin</sub>	Low-level output current @V <sub>OL</sub> =0.4V	3			mA
I <sub>OLmin</sub>	Low-level output current @V <sub>OL</sub> =0.6V for full drive load (400pF/400KHz)	6			mA
t <sub>OF</sub>	Output fall time from V <sub>IHmin</sub> to V <sub>ILmax</sub> with a bus capacitance CB from 10 pF to 200 pF (Proper External Resistor Value should be used as per I <sup>2</sup> C spec)	20+0.1 × C <sub>b</sub>		250	ns
	Output fall time from V <sub>IHmin</sub> to V <sub>ILmax</sub> with a bus capacitance CB from 300 pF to 400 pF (Proper External Resistor Value should be used as per I <sup>2</sup> C spec)	40		290	

(1) V<sub>DD5</sub> stands for corresponding power supply (that is, vddshv3). For more information on the power supply name and the corresponding ball, see [Table 4-1](#), POWER [10] column.

(2) For more information on the I/O cell configurations, see the Control Module section of the Device TRM.

**Table 5-8. IQ1833 Buffers DC Electrical Characteristics**

over operating free-air temperature range (unless otherwise noted)

PARAMETER		MIN	NOM	MAX	UNIT
<b>Signal Names in MUXMODE 0:</b> tclk					
<b>Balls:</b> K21					
<b>1.8-V Mode</b>					
V <sub>IH</sub>	Input high-level threshold (Does not meet JEDEC V <sub>IH</sub> )	0.75 × V <sub>DD5</sub>			V
V <sub>IL</sub>	Input low-level threshold (Does not meet JEDEC V <sub>IL</sub> )			0.25 × V <sub>DD5</sub>	V
V <sub>HYS</sub>	Input hysteresis voltage	100			mV

**Table 5-8. IQ1833 Buffers DC Electrical Characteristics (continued)**

over operating free-air temperature range (unless otherwise noted)

PARAMETER		MIN	NOM	MAX	UNIT
$I_{IN}$	Input current at each I/O pin	2		11	$\mu\text{A}$
$C_{PAD}$	Pad capacitance (including package capacitance)			1	pF
<b>3.3-V Mode</b>					
$V_{IH}$	Input high-level threshold (Does not meet JEDEC $V_{IH}$ )	2.0			V
$V_{IL}$	Input low-level threshold (Does not meet JEDEC $V_{IL}$ )			0.6	V
$V_{HYS}$	Input hysteresis voltage	400			mV
$I_{IN}$	Input current at each I/O pin	5		11	$\mu\text{A}$
$C_{PAD}$	Pad capacitance (including package capacitance)			1	pF

(1) VDD5 stands for corresponding power supply (that is, vddshv3). For more information on the power supply name and the corresponding ball, see [Table 4-1](#), POWER [11] column.

**Table 5-9. IHHV1833 Buffers DC Electrical Characteristics**

over operating free-air temperature range (unless otherwise noted)

PARAMETER		MIN	NOM	MAX	UNIT
<b>Signal Names in MUXMODE 0:</b> porz / wakeup3 / wakeup0					
<b>Balls:</b> <a href="#">AB10</a> / <a href="#">AC10</a> / <a href="#">F19</a>					
<b>1.8-V Mode</b>					
$V_{IH}$	Input high-level threshold	1.2			V
$V_{IL}$	Input low-level threshold			0.4	V
$V_{HYS}$	Input hysteresis voltage	40			mV
$I_{IN}$	Input current at each I/O pin	0.02		1	$\mu\text{A}$
$C_{PAD}$	Pad capacitance (including package capacitance)			1	pF
<b>3.3-V Mode</b>					
$V_{IH}$	Input high-level threshold	1.2			V
$V_{IL}$	Input low-level threshold			0.4	V
$V_{HYS}$	Input hysteresis voltage	40			mV
$I_{IN}$	Input current at each I/O pin	5		8	$\mu\text{A}$
$C_{PAD}$	Pad capacitance (including package capacitance)			1	pF

**Table 5-10. LVCMOS CSI2 DC Electrical Characteristics**

over operating free-air temperature range (unless otherwise noted)

PARAMETER		MIN	NOM	MAX	UNIT
<b>Signals MUXMODE 0 :</b> csi2_0_dx[2:0]; csi2_0_dy[2:0]					
<b>Bottom Balls:</b> <a href="#">AC1</a> / <a href="#">AB2</a> / <a href="#">AD1</a> / <a href="#">AC2</a> / <a href="#">AE2</a> / <a href="#">AD2</a>					
<b>MIPI D-PHY Mode Low-Power Receiver (LP-RX)</b>					
$V_{IH}$	Input high-level voltage	880		1350	mV
$V_{IL}$	Input low-level voltage			550	mV
$V_{ITH}$	Input high-level threshold <sup>(1)</sup>			880	mV
$V_{ITL}$	Input low-level threshold <sup>(2)</sup>	550			mV
$V_{HYS}$	Input hysteresis <sup>(3)</sup>	25			mV
<b>MIPI D-PHY Mode Ultralow Power Receiver (ULP-RX)</b>					
$V_{IL}$	Input low-level voltage			300	mV
$V_{ITL}$	Input low-level threshold <sup>(4)</sup>	300			mV
$V_{HYS}$	Input hysteresis <sup>(3)</sup>	25			mV
<b>MIPI D-PHY Mode High-Speed Receiver (HS-RX)</b>					
$V_{IDTH}$	Differential input high-level threshold	70			mV

**Table 5-10. LVCMOS CSI2 DC Electrical Characteristics (continued)**

over operating free-air temperature range (unless otherwise noted)

PARAMETER		MIN	NOM	MAX	UNIT
V <sub>IDTL</sub>	Differential input low-level threshold			-70	mV
V <sub>IDMAX</sub>	Maximum differential input voltage <sup>(7)</sup>			270	mV
V <sub>IHHS</sub>	Single-ended input high voltage <sup>(5)</sup>			460	mV
V <sub>ILHS</sub>	Single-ended input low voltage <sup>(5)</sup>	-40			mV
V <sub>CMRXDC</sub>	Differential input common-mode voltage <sup>(5)(6)</sup>	70		330	mV
Z <sub>ID</sub>	Differential input impedance	80	100	125	Ω

- (1) V<sub>ITH</sub> is the voltage at which the receiver is required to detect a high state in the input signal.
- (2) V<sub>ITL</sub> is the voltage at which the receiver is required to detect a low state in the input signal. V<sub>ITL</sub> is larger than the maximum single-ended line high voltage during HS transmission. Therefore, both low-power (LP) receivers will detect low during HS signaling.
- (3) To reduce noise sensitivity on the received signal, the LP receiver is required to incorporate a hysteresis, V<sub>HYST</sub>. V<sub>HYST</sub> is the difference between the V<sub>ITH</sub> threshold and the V<sub>ITL</sub> threshold.
- (4) V<sub>ITL</sub> is the voltage at which the receiver is required to detect a low state in the input signal. Specification is relaxed for detecting 0 during ultralow power (ULP) state. The LP receiver is not required to detect HS single-ended voltage as 0 in this state.
- (5) Excluding possible additional RF interference of 200 mV<sub>PP</sub> beyond 450 MHz.
- (6) This value includes a ground difference of 50 mV between the transmitter and the receiver, the static common-mode level tolerance and variations below 450 MHz.
- (7) This number corresponds to the VOD<sub>MAX</sub> transmitter.
- (8) Common mode is defined as the average voltage level of X and Y: V<sub>CMRX</sub> = (V<sub>X</sub> + V<sub>Y</sub>) / 2.
- (9) Common mode ripple may be due to t<sub>R</sub> or t<sub>F</sub> and transmission line impairments in the PCB.
- (10) For more information regarding the pin name (or ball name) and corresponding signal name, see [Table 4-5 CSI 2 Signal Descriptions](#).

**Table 5-11. Dual Voltage SDIO1833 DC Electrical Characteristics**

over operating free-air temperature range (unless otherwise noted)

PARAMETER		MIN	NOM	MAX	UNIT
<b>Signal Names in Mode 0:</b> mmc1_clk, mmc1_cmd, mmc1_data[3:0]					
<b>Bottom Balls:</b> U3 / V4 / V3 / V2 / W1 / V1					
<b>1.8-V Mode</b>					
V <sub>IH</sub>	Input high-level threshold	1.27			V
V <sub>IL</sub>	Input low-level threshold			0.58	V
V <sub>HYS</sub>	Input hysteresis voltage	50 <sup>(2)</sup>			mV
I <sub>IN</sub>	Input current at each I/O pin			30	μA
I <sub>OZ</sub>	I <sub>OZ</sub> (I <sub>PAD</sub> Current) for BIDI cell. This current is contributed by the tristated driver leakage + input current of the Rx + weak pullup/pulldown leakage. PAD is swept from 0 to VDD5 and the Max(I(PAD)) is measured and is reported as I <sub>OZ</sub>			30	μA
I <sub>IN</sub> with pulldown enabled	Input current at each I/O pin with weak pulldown enabled measured when PAD = VDD5	50	120	210	μA
I <sub>IN</sub> with pullup enabled	Input current at each I/O pin with weak pullup enabled measured when PAD = 0	60	120	200	μA
C <sub>PAD</sub>	Pad capacitance (including package capacitance)			5	pF
V <sub>OH</sub>	Output high-level threshold (I <sub>OH</sub> = 2 mA)	1.4			V
V <sub>OL</sub>	Output low-level threshold (I <sub>OL</sub> = 2 mA)			0.45	V
<b>3.3-V Mode</b>					
V <sub>IH</sub>	Input high-level threshold	0.625 × VDD5			V
V <sub>IL</sub>	Input low-level threshold			0.25 × VDD5	V
V <sub>HYS</sub>	Input hysteresis voltage	40 <sup>(2)</sup>			mV
I <sub>IN</sub>	Input current at each I/O pin			110	μA

**Table 5-11. Dual Voltage SDIO1833 DC Electrical Characteristics (continued)**

over operating free-air temperature range (unless otherwise noted)

PARAMETER		MIN	NOM	MAX	UNIT
$I_{OZ}$	$I_{OZ}$ ( $I_{PAD}$ Current) for BIDI cell. This current is contributed by the tristated driver leakage + input current of the Rx + weak pullup/pulldown leakage. PAD is swept from 0 to VDD5 and the $\text{Max}(I_{(PAD)})$ is measured and is reported as $I_{OZ}$			110	$\mu\text{A}$
$I_{IN}$ with pulldown enabled	Input current at each I/O pin with weak pulldown enabled measured when PAD = VDD5	40	100	290	$\mu\text{A}$
$I_{IN}$ with pullup enabled	Input current at each I/O pin with weak pullup enabled measured when PAD = 0	10	100	290	$\mu\text{A}$
$C_{PAD}$	Pad capacitance (including package capacitance)			5	pF
$V_{OH}$	Output high-level threshold ( $I_{OH} = 2\text{ mA}$ )	$0.75 \times VDD5$			V
$V_{OL}$	Output low-level threshold ( $I_{OL} = 2\text{ mA}$ )			$0.125 \times VDD5$	V

(1) VDD5 stands for corresponding power supply (that is, vddshv8). For more information on the power supply name and the corresponding ball, see [Table 4-1, POWER \[10\]](#) column.

(2) Hysteresis is enabled/disabled with CTRL\_CORE\_CONTROL\_HYST\_1.SDCARD\_HYST register.

**Table 5-12. Dual Voltage LVCMOS DC Electrical Characteristics**

over operating free-air temperature range (unless otherwise noted)

PARAMETER		MIN	NOM	MAX	UNIT
<b>1.8-V Mode</b>					
$V_{IH}$	Input high-level threshold	$0.65 \times VDD5$			V
$V_{IL}$	Input low-level threshold			$0.35 \times VDD5$	V
$V_{HYS}$	Input hysteresis voltage	100			mV
$V_{OH}$	Output high-level threshold ( $I_{OH} = 2\text{ mA}$ )	$VDD5-0.45$			V
$V_{OL}$	Output low-level threshold ( $I_{OL} = 2\text{ mA}$ )			0.45	V
$I_{DRIVE}$	Pin Drive strength at PAD Voltage = 0.45V or $VDD5-0.45\text{V}$	6			mA
$I_{IN}$	Input current at each I/O pin			16	$\mu\text{A}$
$I_{OZ}$	$I_{OZ}$ ( $I_{PAD}$ Current) for BIDI cell. This current is contributed by the tristated driver leakage + input current of the Rx + weak pullup/pulldown leakage. PAD is swept from 0 to VDD5 and the $\text{Max}(I_{(PAD)})$ is measured and is reported as $I_{OZ}$			16	$\mu\text{A}$
$I_{IN}$ with pulldown enabled	Input current at each I/O pin with weak pulldown enabled measured when PAD = VDD5	50	120	210	$\mu\text{A}$
$I_{IN}$ with pullup enabled	Input current at each I/O pin with weak pullup enabled measured when PAD = 0	60	120	200	$\mu\text{A}$
$C_{PAD}$	Pad capacitance (including package capacitance)			4	pF
$Z_O$	Output impedance (drive strength)		40		$\Omega$
<b>3.3-V Mode</b>					
$V_{IH}$	Input high-level threshold	2			V
$V_{IL}$	Input low-level threshold			0.8	V
$V_{HYS}$	Input hysteresis voltage	200			mV
$V_{OH}$	Output high-level threshold ( $I_{OH} = 100\ \mu\text{A}$ )	$VDD5-0.2$			V
$V_{OL}$	Output low-level threshold ( $I_{OL} = 100\ \mu\text{A}$ )			0.2	V
$I_{DRIVE}$	Pin Drive strength at PAD Voltage = 0.45V or $VDD5-0.45\text{V}$	6			mA
$I_{IN}$	Input current at each I/O pin			65	$\mu\text{A}$

**Table 5-12. Dual Voltage LVCMOS DC Electrical Characteristics (continued)**

over operating free-air temperature range (unless otherwise noted)

PARAMETER		MIN	NOM	MAX	UNIT
$I_{OZ}$	$I_{OZ}$ ( $I_{PAD}$ Current) for BIDI cell. This current is contributed by the tristated driver leakage + input current of the Rx + weak pullup/pulldown leakage. PAD is swept from 0 to VDD5 and the $\text{Max}(I_{(PAD)})$ is measured and is reported as $I_{OZ}$			65	$\mu\text{A}$
$I_{IN}$ with pulldown enabled	Input current at each I/O pin with weak pulldown enabled measured when PAD = VDD5	40	100	200	$\mu\text{A}$
$I_{IN}$ with pullup enabled	Input current at each I/O pin with weak pullup enabled measured when PAD = 0	10	100	290	$\mu\text{A}$
$C_{PAD}$	Pad capacitance (including package capacitance)			4	pF
$Z_O$	Output impedance (drive strength)		40		$\Omega$

(1) VDD5 stands for corresponding power supply. For more information on the power supply name and the corresponding ball, see [Table 4-1](#), POWER [10] column.

### 5.7.1 USBPHY DC Electrical Characteristics

#### NOTE

USB1 instance is compliant with the USB3.0 SuperSpeed Transmitter and Receiver Normative Electrical Parameters as defined in the USB3.0 Specification Rev 1.0 dated Jun 6, 2011.

#### NOTE

USB1 and USB2 Electrical Characteristics are compliant with USB2.0 Specification Rev 2.0 dated April 27, 2000 including ECNs and Errata as applicable.

### 5.7.2 HDMIPHY DC Electrical Characteristics

#### NOTE

The HDMIPHY DC Electrical Characteristics are compliant with the HDMI 1.4a specification and are not reproduced here.

### 5.7.3 PCIEPHY DC Electrical Characteristics

#### NOTE

The PCIe interfaces are compliant with the electrical parameters specified in PCI Express® Base Specification Revision 3.0.

## 5.8 VPP Specifications for One-Time Programmable (OTP) eFuses

This section specifies the operating conditions required for programming the OTP eFuses and is applicable only for High-Security Devices.

**Table 5-13. Recommended Operating Conditions for OTP eFuse Programming**

over operating free-air temperature range (unless otherwise noted)

PARAMETER	DESCRIPTION	MIN	NOM	MAX	UNIT
vdd	Supply voltage range for the core domain during OTP operation	1.11	1.15	1.2	V
vpp	Supply voltage range for the eFuse ROM domain during normal operation	NC			V
	Supply voltage range for the eFuse ROM domain during OTP programming <sup>(1)(2)</sup>	1.8			V
I(vpp)				100	mA
T <sub>j</sub>	Temperature (junction)	0	25	85	°C

(1) Supply voltage range includes DC errors and peak-to-peak noise. TI power management solutions [TLV70018-Q1](#) from the TLV700xx family meet the supply voltage range needed for vpp.

(2) During normal operation, no voltage should be applied to vpp. This can be typically achieved by disabling the regulator attached to the vpp terminal. For more details, see [TLV700xx-Q1 300-mA, Low-I<sub>Q</sub>, Low-Dropout Regulator](#).

### 5.8.1 Hardware Requirements

The following hardware requirements must be met when programming keys in the OTP eFuses:

- The vpp power supply must be disabled when not programming OTP registers.
- The vpp power supply must be ramped up after the proper device power-up sequence (for more details, see [Section 5.10.3](#)).

### 5.8.2 Programming Sequence

Programming sequence for OTP eFuses:

1. Power on the board per the power-up sequencing. No voltage should be applied on the vpp terminal during power up and normal operation.
2. Load the OTP write software required to program the eFuse (contact your local TI representative for the OTP software package).
3. Apply the voltage on the vpp terminal according to the specification in [Table 5-13](#).
4. Run the software that programs the OTP registers.
5. After validating the content of the OTP registers, remove the voltage from the vpp terminal.

### 5.8.3 Impact to Your Hardware Warranty

You accept that e-Fusing the TI Devices with security keys permanently alters them. You acknowledge that the e-Fuse can fail, for example, due to incorrect or aborted program sequence or if you omit a sequence step. Further the TI Device may fail to secure boot if the error code correction check fails for the Production Keys or if the image is not signed and optionally encrypted with the current active Production Keys. These types of situations will render the TI Device inoperable and TI will be unable to confirm whether the TI Devices conformed to their specifications prior to the attempted e-Fuse. **CONSEQUENTLY, TI WILL HAVE NO LIABILITY (WARRANTY OR OTHERWISE) FOR ANY TI DEVICES THAT HAVE BEEN e-FUSED WITH SECURITY KEYS.**

## 5.9 Thermal Resistance Characteristics for CBD Package

For reliability and operability concerns, the maximum junction temperature of the Device has to be at or below the T<sub>j</sub> value identified in [Section 5.4, Recommended Operating Conditions](#).

A BCI compact thermal model for this Device is available and recommended for use when modeling thermal performance in a system.

Therefore, it is recommended to perform thermal simulations at the system level with the worst case device power consumption.

### 5.9.1 Package Thermal Characteristics

Table 5-14 provides the thermal resistance characteristics for the package used on this device.

#### NOTE

Power dissipation of 3.0 W and an ambient temperature of 85°C is assumed for CBD package.

**Table 5-14. Thermal Resistance Characteristics**

NO.	PARAMETER	DESCRIPTION	°C/W <sup>(1)</sup>	AIR FLOW (m/s) <sup>(2)</sup>	
T1	R $\theta_{JC}$	Junction-to-case	0.23	N/A	
T2	R $\theta_{JB}$	Junction-to-board	3.65	N/A	
T3	R $\theta_{JA}$	Junction-to-free air	12.8	0	
T4			10.4	0.5	
T5			Junction-to-moving air	9.6	1
T6				8.8	2
T7				8.3	3
T8	$\Psi_{JT}$	Junction-to-package top	0.1	0	
T9			0.1	0.5	
T10			0.1	1	
T11			0.1	2	
T12			0.1	3	
T13	$\Psi_{JB}$	Junction-to-board	3.7	0	
T14			3.7	0.5	
T15			3.6	1	
T16			3.6	2	
T17			3.5	3	

(1) These measurements were conducted in a JEDEC defined 2S2P system (with the exception of the Theta JC [R $\theta_{JC}$ ] measurement, which was conducted in a JEDEC defined 1S0P system) and will change based on environment as well as application. For more information, see these EIA/JEDEC standards:

- JESD51-2, *Integrated Circuits Thermal Test Method Environment Conditions - Natural Convection (Still Air)*
- JESD51-3, *Low Effective Thermal Conductivity Test Board for Leaded Surface Mount Packages*
- JESD51-7, *High Effective Thermal Conductivity Test Board for Leaded Surface Mount Packages*
- JESD51-9, *Test Boards for Area Array Surface Mount Packages*

(2) m/s = meters per second



## 5.10 Timing Requirements and Switching Characteristics

### 5.10.1 Timing Parameters and Information

The timing parameter symbols used in the timing requirement and switching characteristic tables are created in accordance with JEDEC Standard 100. To shorten the symbols, some of pin names and other related terminologies have been abbreviated as follows:

**Table 5-15. Timing Parameters**

SUBSCRIPTS	
SYMBOL	PARAMETER
c	Cycle time (period)
d	Delay time
dis	Disable time
en	Enable time
h	Hold time
su	Setup time
START	Start bit
t	Transition time
v	Valid time
w	Pulse duration (width)
X	Unknown, changing, or don't care level
F	Fall time
H	High
L	Low
R	Rise time
V	Valid
IV	Invalid
AE	Active Edge
FE	First Edge
LE	Last Edge
Z	High impedance

### 5.10.1.1 Parameter Information

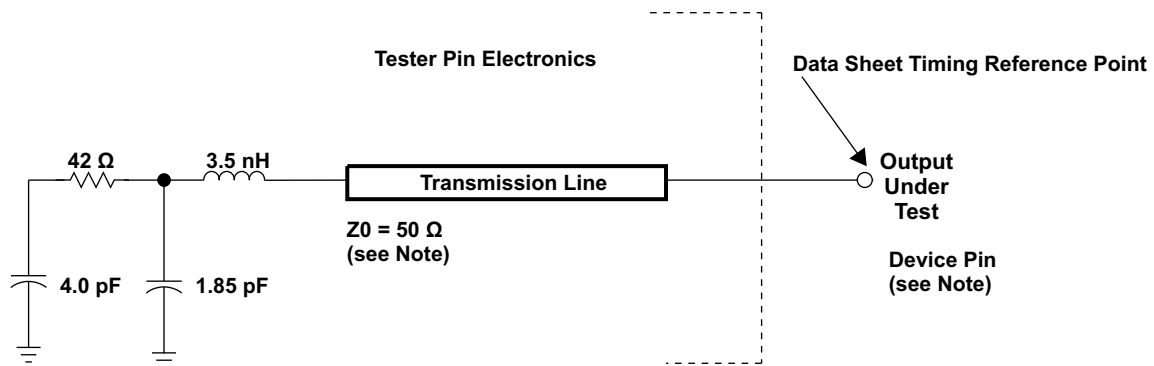

NOTE: The data sheet provides timing at the device pin. For output timing analysis, the tester pin electronics and its transmission line effects must be taken into account. A transmission line with a delay of 2 ns can be used to produce the desired transmission line effect. The transmission line is intended as a load only. It is not necessary to add or subtract the transmission line delay (2 ns) from the data sheet timings.

Input requirements in this data sheet are tested with an input slew rate of < 4 Volts per nanosecond (4 V/ns) at the device pin.

pm\_tstcirc\_prs403

**Figure 5-2. Test Load Circuit for AC Timing Measurements**

The load capacitance value stated is only for characterization and measurement of AC timing signals.

This load capacitance value does not indicate the maximum load the device is capable of driving.

#### 5.10.1.1.1 1.8 V and 3.3 V Signal Transition Levels

All input and output timing parameters are referenced to  $V_{ref}$  for both "0" and "1" logic levels.  $V_{ref} = (V_{DD} I/O)/2$ .

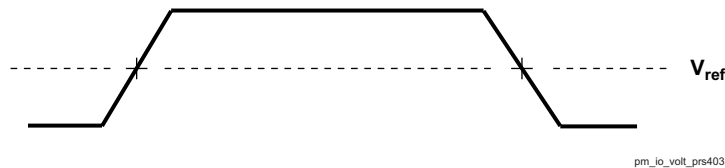

pm\_io\_volt\_prs403

**Figure 5-3. Input and Output Voltage Reference Levels for AC Timing Measurements**

All rise and fall transition timing parameters are referenced to  $V_{IL} MAX$  and  $V_{IH} MIN$  for input clocks,  $V_{OL} MAX$  and  $V_{OH} MIN$  for output clocks.

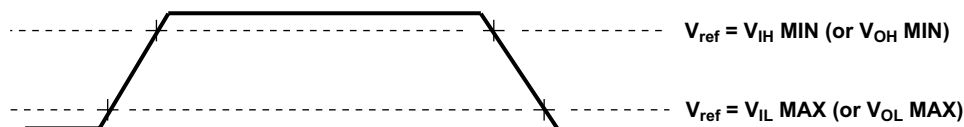

pm\_transvolt\_prs403

**Figure 5-4. Rise and Fall Transition Time Voltage Reference Levels**

#### 5.10.1.1.2 1.8 V and 3.3 V Signal Transition Rates

The default SLEWCONTROL settings in each pad configuration register must be used to ensure timings, unless specific instructions otherwise are given in the individual timing subsections of the datasheet.

All timings are tested with an input edge rate of 4 volts per nanosecond (4 V/ns).

### 5.10.1.1.3 Timing Parameters and Board Routing Analysis

The timing parameter values specified in this data manual do not include delays by board routes. As a good board design practice, such delays must *always* be taken into account. Timing values may be adjusted by increasing/decreasing such delays. TI recommends using the available I/O buffer information specification (IBIS) models to analyze the timing characteristics correctly. To properly use IBIS models to attain accurate timing analysis for a given system, see the [Using IBIS Models for timing Analysis](#) application report. If needed, external logic hardware such as buffers may be used to compensate any timing differences.

## 5.10.2 Interface Clock Specifications

### 5.10.2.1 Interface Clock Terminology

The interface clock is used at the system level to sequence the data and/or to control transfers accordingly with the interface protocol.

### 5.10.2.2 Interface Clock Frequency

The two interface clock characteristics are:

- The maximum clock frequency
- The maximum operating frequency

The interface clock frequency documented in this document is the maximum clock frequency, which corresponds to the maximum frequency programmable on this output clock. This frequency defines the maximum limit supported by the Device IC and does not take into account any system consideration (PCB, peripherals).

The system designer will have to consider these system considerations and the Device IC timing characteristics as well to define properly the maximum operating frequency that corresponds to the maximum frequency supported to transfer the data on this interface.

## 5.10.3 Power Supply Sequences

This section describes the power-up and power-down sequence required to ensure proper device operation. The power supply names described in this section comprise a superset of a family of compatible devices. Some members of this family will not include a subset of these power supplies and their associated device modules. Refer to the [Section 4.2, Pin Attributes](#) of the [Section 4, Terminal Configuration and Functions](#) to determine which power supplies are applicable.

Figure 5-5 through Figure 5-9 and associated notes described the device Recommended Power Sequencing.

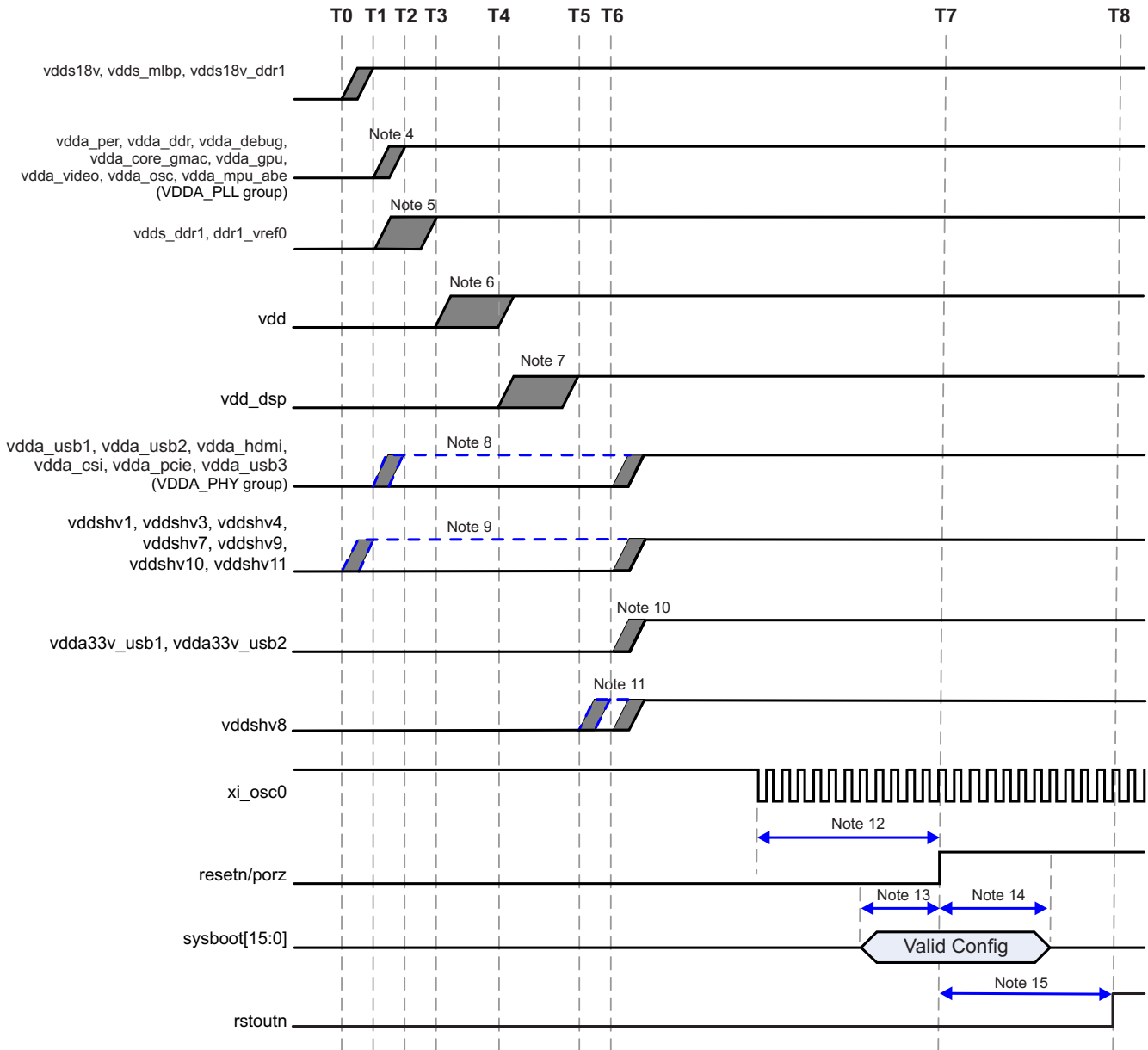

**Figure 5-5. Recommended Power-Up Sequencing**

- (1) T0 = 0ms, T1 = 0.55ms, T2 = 1.1ms, T3 = 1.65ms, T4 = 2.2ms, T5 = 2.75ms, T6 = 3.3ms, T7 = 6.9ms, T8 ≈ 9ms. All "Tn" markers show total elapsed time from T0.
- (2) Terminology:
  - $V_{OPR\ MIN}$  = Minimum Operational Voltage level that ensures device functionality and specified performance per [Section 5.4, Recommended Operating Conditions](#).
  - Ramp Up = transition time from  $V_{OFF}$  to  $V_{OPR\ MIN}$
- (3) General timing diagram items:
  - Grey shaded areas show valid transition times for supplies between  $V_{OPR\ MIN}$  and  $V_{OFF}$ .
  - Dashed horizontal lines are not valid ramp times but show alternate transition times based upon common sources and clarified in associated note.
  - Dashed vertical lines show approximate elapse times based upon T1 recommended PMIC power sequencer circuit performance.
- (4) vdda\_\* rails should not be combined with vdds18v\_\* for best performance to avoid transient switching noise impacts on analog domains. vdda\_\* should not ramp-up before vdds18v\_\* but could ramp concurrently if design ensures final operational voltage will not be reached

SPRS960\_ELCH\_04

until after vdds18v. The preferred sequence has vdda\_\* following vdds18v\_\* to ensure circuit components and PCB design do not cause an inadvertent violation.

- (5) vdds\_dds1 should not ramp-up before vdds18v\_\*. The preferred sequence has vdds\_dds1 following vdds18v\_\* to ensure circuit components and PCB design do not cause an inadvertent violation. vdds\_dds1 can ramp-up before, concurrently or after vdda\_\*, there are no dependencies between vdds\_dds1 and vdda\_\* domains.
  - For DDR2 mode of operation (1.8V), vdds\_dds1 supplies can be combined with all vdds18v\_\* supplies and ramped up together for simplified PDN and power sequencing.
  - If vdds\_dds1 is combined with vdds18v\_dds1 but kept separate from vdds18v on board, then this combined 1.8V DDR supply can come up together or after the vdds18v supply. The 1.8V DDR supply should never ramp up before the vdds18v.
- (6) vdd should not ramp-up before vdds18v\_\* or vdds\_dds1 domains have reached  $V_{OPR\ MIN}$ .
- (7) vdd\_dsp could ramp concurrently with vdd if design ensures:
  - Final vdd\_dsp operational voltage will not be reached until after vdd.
  - vdd\_dsp maintains a voltage level at least 150mV less than vdd during entire ramp time. The preferred sequence has vdd\_dsp following vdd to ensure circuit components and PCB design do not cause an inadvertent violation.
- (8) VDDA\_PHY group:
  - should ramp up concurrently or after vdda33v\_usb[1-2] to avoid unintended current path between vdda\_pcie to vdda33v\_usb1 during power sequencing.
  - could ramp up concurrently with VDDA\_PLL group only if the vdda33v\_usb1 power resource has an “off impedance” greater than 100Ω.
- (9) vddshv[1, 3-4, 7, 9-11] domains:
  - If 1.8V I/O signaling is needed, then 1.8V must be sourced from common vdds18v supply and ramp up concurrently with vdds18v.
  - If any 3.3V I/O signaling is needed, then the desired 3.3V vddshv[1, 3-4, 7, 9-11] rails must ramp up after vdd\_dsp.
- (10) vdda33v\_usb[1-2] domain should:
  - ramp up before or concurrently with VDDA\_PHY group if USB signaling is needed and to avoid unintended current path between vdda\_pcie to vdda33v\_usb[1-2] during power sequencing.
  - connect to 3.3V vddshv[1, 3-4, 7, 9-11] common supply if USB signaling is not needed since USB analog power ball also supplies digital IO buffers that must be powered during operation.
- (11) vddshv8 shows two ramp up options for 1.8V I/O or 3.3V I/O or SD Card operation:
  - If 1.8V I/O signaling is needed, then vddshv8 must ramp up after vdd and before or concurrently with 3.3V vddshv\* rails.
  - If 3.3V I/O signaling is needed, then vddshv8 must be combined with other 3.3V vddshv\* rails.
  - If SD Card operation is needed, then vddshv8 must be sourced from a dual voltage (3.3/1.8V) power source per SDIO specifications and ramp up concurrently with 3.3V vddshv\* rails.
- (12) porz must remain asserted low until both of the following conditions are met:
  - Minimum of 12 \*P, where  $P = 1 / (SYS\_CLK1/610)$ , units in ns.
  - All device supply rails reach stable operational levels.
- (13) Setup time: sysboot[15:0] pins must be valid 2P<sup>(12)</sup> before porz is de-asserted high.
- (14) Hold time: sysboot[15:0] pins must be valid 15P<sup>(12)</sup> after porz is de-asserted high.
- (15) rstoutn will be set high after global reset, due to porz, is de-asserted following an internal 2ms delay. rstoutn is only valid after vddshv3 reaches an operational level. If used as a peripheral component reset, it should be AND gated with porz to avoid possible reset glitches during power up.

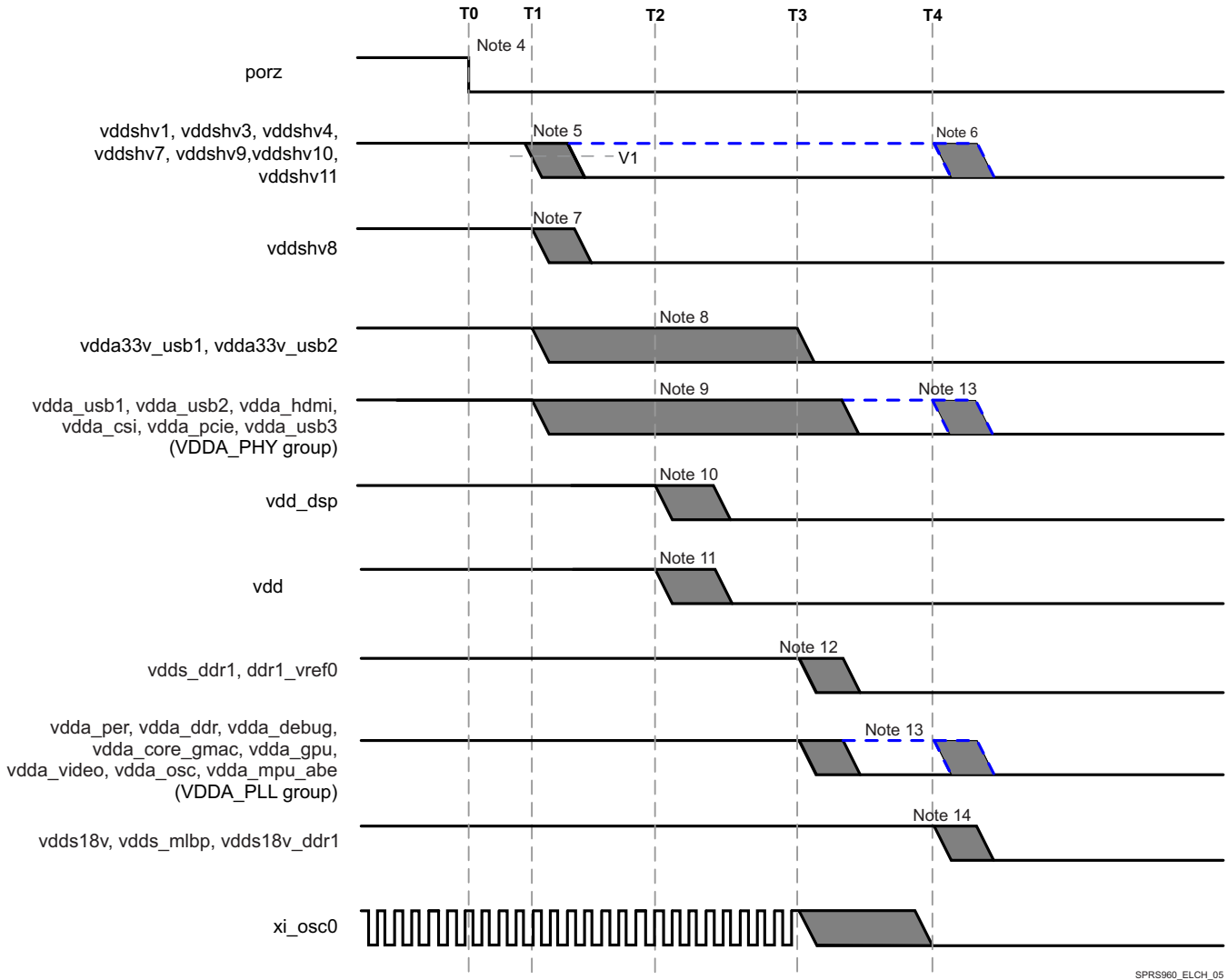

SPRS960\_ELCH\_05

**Figure 5-6. Recommended Power-Down Sequencing**

- (1)  $T1 \geq 100 \mu\text{s}$ ;  $T2 = 500 \mu\text{s}$ ;  $T3 = 1.0 \text{ ms}$ ;  $T4 = 1.5 \text{ ms}$ ;  $V1 = 2.7 \text{ V}$ . All "Tn" markers are intended to show total elapsed time, not interval times.
- (2) Terminology:
  - $V_{\text{OPR MIN}}$  = Minimum Operational Voltage level that ensures device functionality and specified performance in [Section 5.4, Recommended Operating Conditions](#).
  - $V_{\text{OFF}}$  = OFF Voltage level is defined to be less than 0.6 V where any current draw has no impact to POH.
  - Ramp Down = transition time from  $V_{\text{OPR MIN}}$  to  $V_{\text{OFF}}$  and is slew rate independent.
- (3) General timing diagram items:
  - Grey shaded areas show valid transition times for supplies between  $V_{\text{OPR MIN}}$  and  $V_{\text{OFF}}$ .
  - Blue dashed lines are not valid windows but show alternate ramp possibilities based on the associated note.
  - Dashed vertical lines show approximate elapse times based upon T1 recommended PMIC power-down sequencer circuit performance.
- (4) PORz must be asserted low for 100  $\mu\text{s}$  min to ensure SoC is set to a safe functional state before any voltage begins to ramp down.
- (5) vddshv[1, 3-4, 7, 9-11] domains supplied by 3.3 V:
  - must remain greater than 2.7 V to enable Dual Voltage GPIO selector circuit operation for 100  $\mu\text{s}$  min after PORz is asserted low.
  - must be in first group of supplies ramping down after PORz has been asserted low for 100  $\mu\text{s}$  min.
  - must not exceed vdds18v by more than 2 V during ramp down, see [Figure 5-7, "vdds18v versus vddshv\[1, 3-4, 7, 9-11\] Discharge Relationship"](#).
- (6) vddshv[1, 3-4, 7, 9-11] domains supplied by 1.8 V must ramp down concurrently with vdds18v and be sourced from common vdds18v supply.
- (7) vddshv8 supporting SD Card:

- must be sourced from independent power resource that can provide dual voltage (3.3 / 1.8 V) operation as required to be compliant to SDIO specification
  - must be in first group of supplies to ramp down after PORz has been asserted low for 100  $\mu$ s min.
  - if SDIO operation is not needed, must be grouped and ramped down with other vddshv[1, 3-4, 7, 9-11] domains as noted above.
- (8) vdda33v\_usb[1-2] domains:
- can start ramping down 100  $\mu$ s after low assertion of PORz
  - can ramp down concurrently or before VDDA\_PHY group
- (9) VDDA\_PHY domain group must ramp down concurrently or after vdda33v\_usb[1-2].
- (10) vdd\_dsp domain can ramp down before or concurrently with vdd.
- (11) vdd ramp down after or concurrently with vdd\_dsp.
- (12) vdds\_dds1 domain:
- should ramp down after vdd begins ramping down.
  - If DDR2 memory is used (requiring 1.8V supply),
    - then vdds\_dds1 can be combined with vdds18v and vdds18v\_dds1 domains and sourced from a common supply. Accordingly, all domains can ramp down concurrently with vdds18v.
    - if vdds\_dds1 and vdds18v\_dds1 are combined but kept separate from vdds18v, then the combined 1.8V DDR supply can ramp down before or concurrently with vdds18v.
- (13) vdda\_\* domains:
- can ramp down before, concurrently or after vdds\_dds1, there is no dependency between these supplies.
  - can ramp down before or concurrently with vdds18v.
  - must satisfy the vdds18v versus vdda\_\* discharge relationship (see Figure 5-9) if any of the vdda\_\* disable point is later or discharge rate is slower than vdds18v.
- (14) vdds18v domain:
- should maintain  $V_{OPR\ MIN}$  ( $V_{NOM} -5\% = 1.71\ V$ ) until all other supplies start to ramp down.
  - must satisfy the vdds18v versus vddshv[1, 3-4, 7, 9-11] discharge relationship (see Figure 5-7) if any of the vddshv[1, 3-4, 7, 9-11] is operating at 3.3 V.
  - must satisfy the vdds18v versus vdds\_dds1 discharge relationship ( see Figure 5-8) if vdds\_dds1 discharge rate is slower than vdds18v.

Figure 5-7 describes vddshv[1, 3-4, 7, 9-11] Supplies Falling Before vdds18v Supplies Delta.

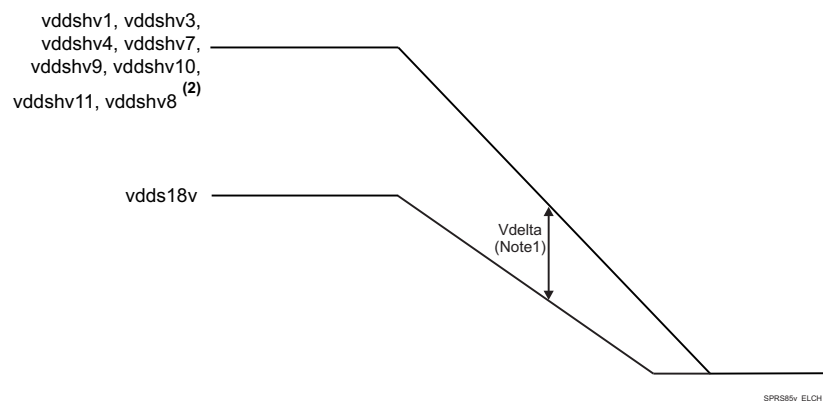
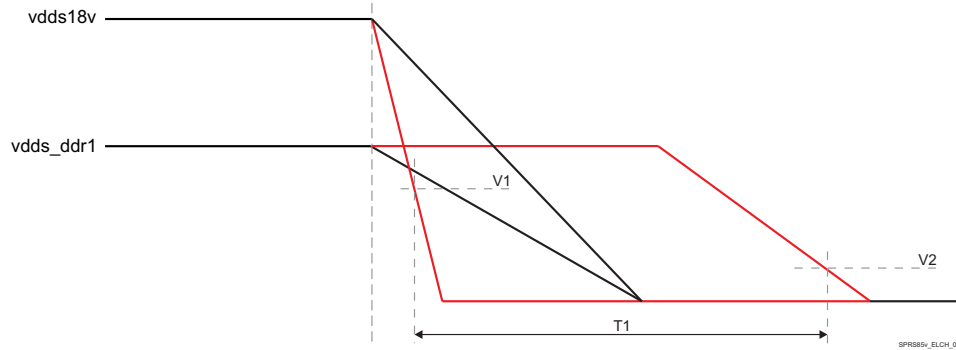

Figure 5-7. vdds18v versus vddshv[1, 3-4, 7, 9-11] Discharge Relationship

- (1)  $V_{\delta\ MAX} = 2V$ .
- (2) If vddshv8 is powered by the same supply source as the other vddshv[1, 3-4, 7, 9-11] rails.

If vdds18v and vdds\_dds1 are disabled at the same time due to a loss of input power event or if vdds\_dds1 discharges more slowly than vdds18v, analysis has shown no reliability impacts when the elapsed time period beginning with vdds18v dropping below 1.0 V and ending with vdds\_dds1 dropping below 0.6 V is less than 10 ms (Figure 5-8).



**Figure 5-8. vdds18v and vdds\_dds1 Discharge Relationship<sup>(1)</sup>**

(1)  $V1 > 1.0\text{ V}$ ;  $V2 < 0.6\text{ V}$ ;  $T1 < 10\text{ms}$ .

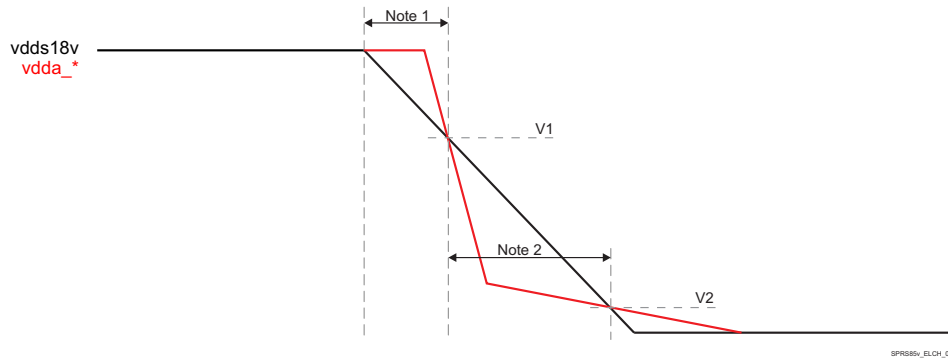

**Figure 5-9. vdds18v and vdda\_\* Discharge Relationship<sup>(3)</sup>**

- (1) vdda\_\* can be  $\geq$  vdds18v, until vdds18v drops below 1.62 V.
- (2) vdds18v must be  $\geq$  vdda\_\*, until vdds18v reaches 0.6 V.
- (3)  $V1 = 1.62\text{ V}$ ;  $V2 < 0.6\text{ V}$ .



Figure 5-7 through Figure 5-10 and associated notes described the device Abrupt Power Down Sequence.

A "loss of input power event" occurs when the system's input power is unexpectedly removed. Normally, the recommended power-down sequence should be followed and can be accomplished within 1.5-2 ms of elapsed time. This is the typical range of elapsed time available following a loss of power event, see Section 7.3.7 for design recommendations. If sufficient elapse time is not provided, then an "abrupt" power-down sequence can be supported without impacting POH reliability if all of the following conditions are met (Figure 5-10).

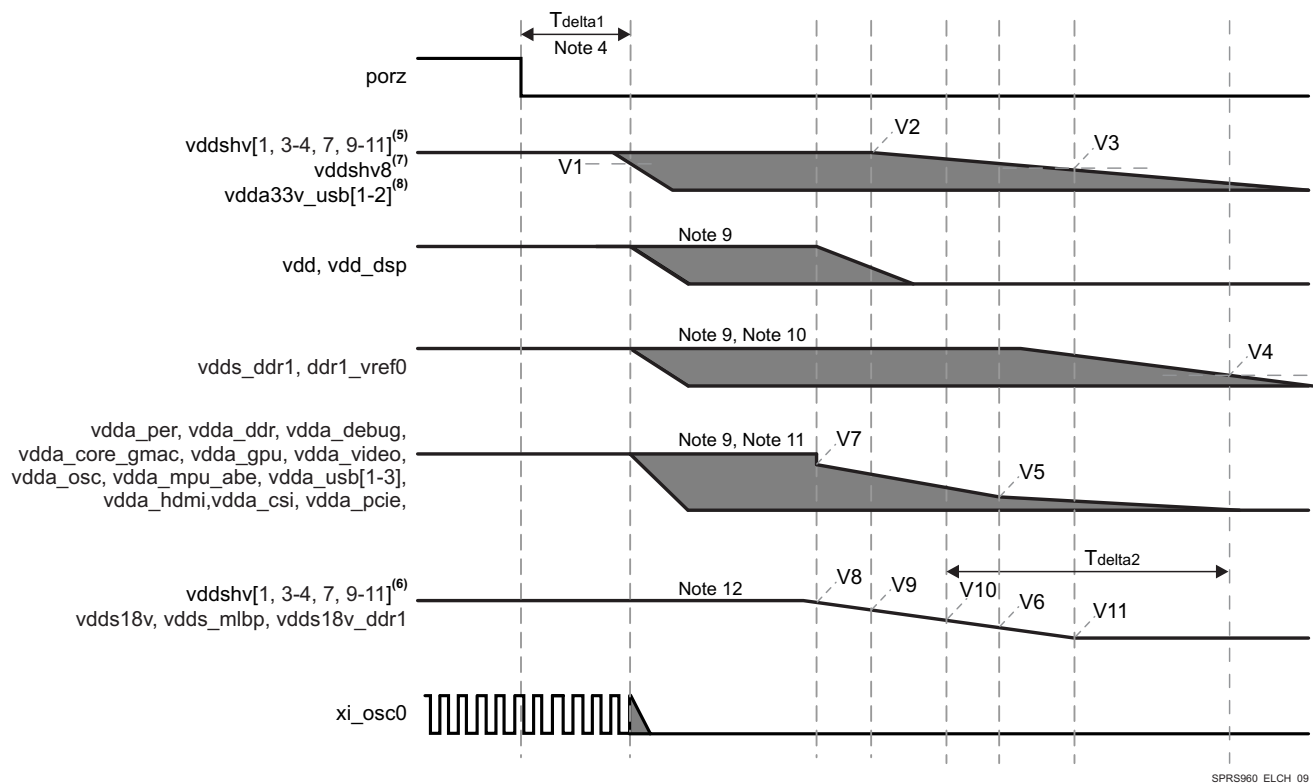

Figure 5-10. Abrupt Power-Down Sequencing<sup>(1)</sup>

(1) V1 = 2.7 V; V2 = 3.3 V; V3 = 2.0 V; V4 = V5 = V6 = 0.6 V; V7 = V8 = 1.62 V; V9 = 1.3 V; V10 = 1.0 V; V11 = 0.0 V;  $T_{\text{delta}1} > 100 \mu\text{s}$ ;  $T_{\text{delta}2} < 10 \text{ms}$ .

(2) Terminology:

- $V_{\text{OPR MIN}}$  = Minimum Operational Voltage level that ensures device functionality and specified performance in Section 5.4, *Recommended Operating Conditions*.
- $V_{\text{OFF}}$  = OFF Voltage level is defined to be less than 0.6 V, where any current draw has no impact to POH.
- Ramp Down = transition time from  $V_{\text{OPR MIN}}$  to  $V_{\text{OFF}}$  and is slew rate independent.

(3) General timing diagram items:

- Grey shaded areas show valid transition times for supplies between  $V_{\text{OPR MIN}}$  and  $V_{\text{OFF}}$ .
- Dashed vertical lines show approximate elapse times based upon TI recommended PMIC power-down sequencer circuit performance.

(4) PORz must be asserted low for 100  $\mu\text{s}$  min to ensure SoC is set to a safe functional state before any voltage begins to ramp down.

(5) vddshv[1, 3-4, 7, 9-11] domains supplied by 3.3 V:

- must remain greater than 2.7 V to enable Dual Voltage GPIO selector circuit operation for 100 $\mu\text{s}$  min, after PORz is asserted low.
- must not exceed vdds18v voltage level by more than 2V during ramp down, until vdds18v drops below  $V_{\text{OFF}}$  (0.6 V).

(6) vddshv[1, 3-4, 7, 9-11] domains supplied by 1.8 V must ramp down concurrently with vdds18v and be sourced from common vdds18v supply.

(7) vddshv8 supporting SD Card:

- must be in first group of supplies to ramp down after PORz has been asserted low for 100  $\mu\text{s}$  min.
- must be sourced from independent power resource that can provide dual voltage (3.3 / 1.8 V) operation as required to be compliant to SDIO specification.
- if SDIO operation is not needed, must be grouped with other vddshv[1, 3-4, 7, 9-11] domains.

- (8) vdda33v\_usb[1-2] domains must be in first group of supplies to ramp down after PORz has been asserted low for 100  $\mu$ s min.
- (9) vdd\_dsp, vdd, vdds\_dds1, vdda\_\* domains can all start to ramp down in any order after 100  $\mu$ s low assertion of PORz.
- (10) vdds\_dds1 domain:
- can remain at  $V_{OPR\_MIN}$  or a level greater than vdds18v during ramp down.
  - elapsed time from vdds18v dropping below 1.0 V to vdds\_dds1 dropping below 0.6 V must not exceed 10 ms.
- (11) vdda\_\* domains:
- can start to ramp down before or concurrently with vdds18v.
  - must not exceed vdds18v voltage level after vdds18v drops below 1.62 V until vdds18v drops below  $V_{OFF}$  (0.6 V).
- (12) vdds18v domain should maintain a minimum level of 1.62 V ( $V_{NOM} - 10\%$ ) until vdd\_dsp and vdd start to ramp down.

#### 5.10.4 Clock Specifications

---

##### NOTE

For more information, see Power Reset and Clock Management / PRCM Environment / External Clock Signal and Power Reset / PRCM Functional Description / PRCM Clock Manager Functional Description section of the Device TRM.

---

##### NOTE

Audio Back End (ABE) module is not supported for this family of devices, but “ABE” name is still present in some clock or DPLL names.

---

The device operation requires the following clocks:

- The system clocks, SYS\_CLK1 (Mandatory) and SYS\_CLK2 (Optional) are the main clock sources of the device. They supply the reference clock to the DPLLs as well as functional clock to several modules.

The Device also embeds an internal free-running 32-kHz oscillator that is always active as long as the the wake-up (WKUP) domain is supplied.

Figure 5-11 shows the external input clock sources and the output clocks to peripherals.

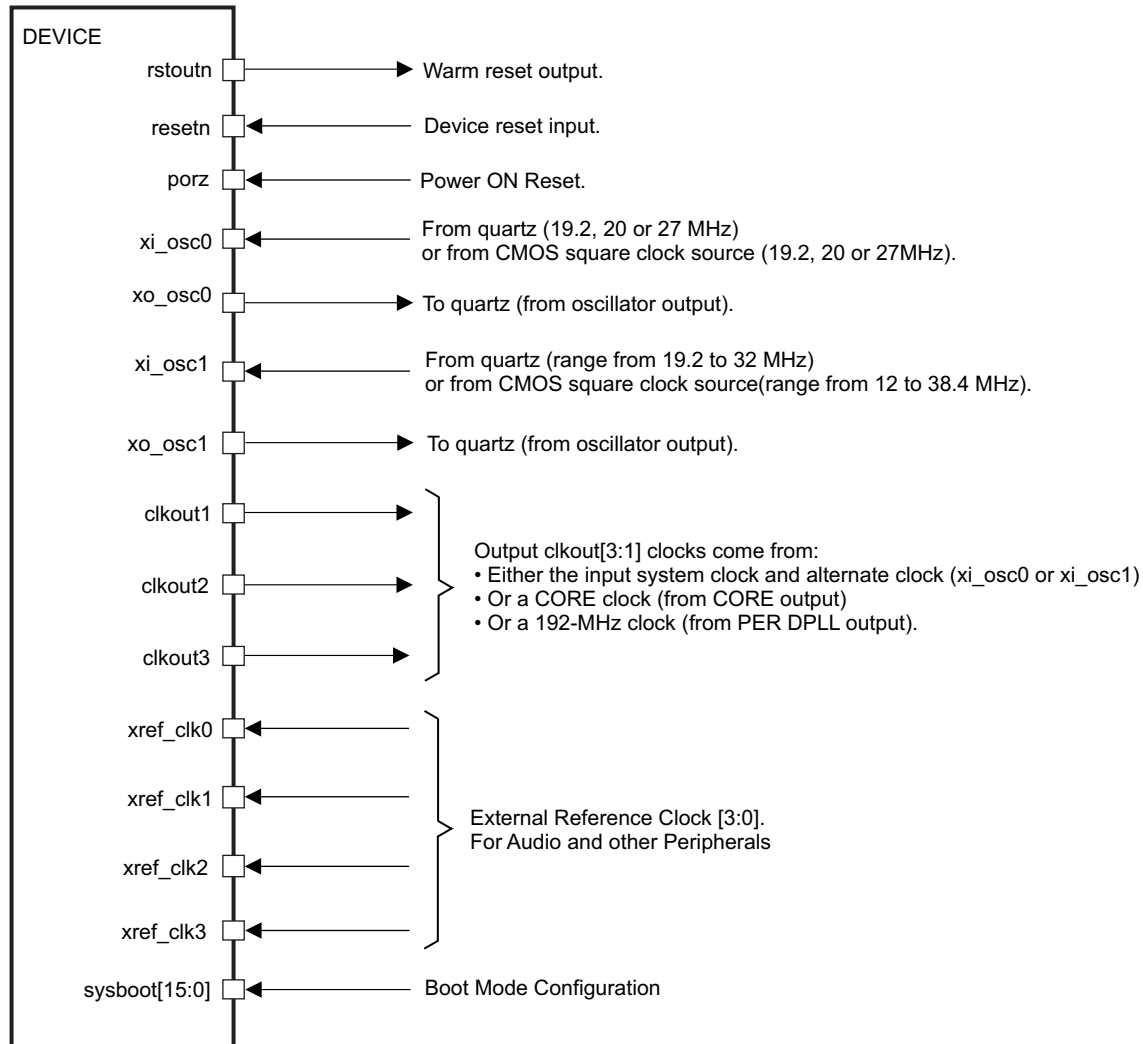

Figure 5-11. Clock Interface

#### 5.10.4.1 Input Clocks / Oscillators

- The source of the internal system clock (SYS\_CLK1) could be either:
  - A CMOS clock that enters on the xi\_osc0 ball (with xo\_osc0 left unconnected on the CMOS clock case).
  - A crystal oscillator clock managed by xi\_osc0 and xo\_osc0.
- The source of the internal system clock (SYS\_CLK2) could be either:
  - A CMOS clock that enters on the xi\_osc1 ball (with xo\_osc1 left unconnected on the CMOS clock case).
  - A crystal oscillator clock managed by xi\_osc1 and xo\_osc1.

SYS\_CLK1 is received directly from oscillator OSC0. For more information about SYS\_CLK1 see Device TRM, Chapter: *Power, Reset, and Clock Management*.

##### 5.10.4.1.1 OSC0 External Crystal

An external crystal is connected to the device pins. [Figure 5-12](#) describes the crystal implementation.

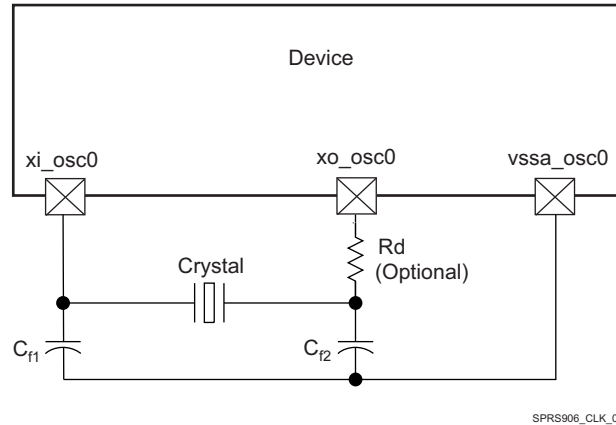

**Figure 5-12. OSC0 Crystal Implementation**

**NOTE**

The load capacitors,  $C_{f1}$  and  $C_{f2}$  in [Figure 5-12](#), should be chosen such that the below equation is satisfied.  $C_L$  in the equation is the load specified by the crystal manufacturer. All discrete components used to implement the oscillator circuit should be placed as close as possible to the associated oscillator  $xi\_osc0$ ,  $xo\_osc0$ , and  $vssa\_osc0$  pins.

$$C_L = \frac{C_{f1} C_{f2}}{(C_{f1} + C_{f2})}$$

**Figure 5-13. Load Capacitance Equation**

The crystal must be in the fundamental mode of operation and parallel resonant. [Table 5-16](#) summarizes the required electrical constraints. and [Table 5-20](#)

**Table 5-16. OSC0 Crystal Electrical Characteristics**

NAME	DESCRIPTION		MIN	TYP	MAX	UNIT
$f_p$	Parallel resonance crystal frequency		19.2, 20, 27			MHz
$C_{f1}$	$C_{f1}$ load capacitance for crystal parallel resonance with $C_{f1} = C_{f2}$		12		24	pF
$C_{f2}$	$C_{f2}$ load capacitance for crystal parallel resonance with $C_{f1} = C_{f2}$		12		24	pF
$ESR(C_{f1}, C_{f2})$	Crystal ESR				100	$\Omega$
$C_O$	Crystal shunt capacitance	ESR = 30 $\Omega$ ESR = 40 $\Omega$	19.2 MHz, 20 MHz, 27 MHz		7	pF
		ESR = 50 $\Omega$	19.2 MHz, 20 MHz 27 MHz		7 5	pF pF
		ESR = 60 $\Omega$	19.2 MHz, 20 MHz 27 MHz		7	pF
		ESR = 80 $\Omega$	19.2 MHz, 20 MHz 27 MHz		5	pF
		ESR = 100 $\Omega$	19.2 MHz, 20 MHz 27 MHz		3	pF
		Not Supported	Not Supported			-
$L_M$	Crystal motional inductance for $f_p = 20$ MHz		10.16			mH
$C_M$	Crystal motional capacitance		3.42			fF

**Table 5-16. OSC0 Crystal Electrical Characteristics (continued)**

NAME	DESCRIPTION	MIN	TYP	MAX	UNIT
t <sub>j(xi_osc0)</sub>	Frequency accuracy <sup>(1)</sup> , xi_osc0	Ethernet and MLB not used		±200	ppm
		Ethernet RGMII and RMII using derived clock		±50	
		Ethernet MII using derived clock		±100	
		MLB using derived clock		±50	

(1) Crystal characteristics should account for tolerance+stability+aging.

When selecting a crystal, the system design must consider the temperature and aging characteristics of a based on the worst case environment and expected life expectancy of the system.

Table 5-17 details the switching characteristics of the oscillator and the requirements of the input clock.

**Table 5-17. Oscillator Switching Characteristics—Crystal Mode**

NAME	DESCRIPTION	MIN	TYP	MAX	UNIT
f <sub>p</sub>	Oscillation frequency	19.2, 20, 27 MHz			MHz
t <sub>sX</sub>	Start-up time	4			ms

**5.10.4.1.2 OSC0 Input Clock**

A 1.8-V LVCMOS-Compatible Clock Input can be used instead of the internal oscillator to provide the SYS\_CLK1 clock input to the system. The external connections to support this are shown in Figure 5-14. The xi\_osc0 pin is connected to the 1.8-V LVCMOS-Compatible clock source. The xi\_osc0 pin is left unconnected. The vssa\_osc0 pin is connected to board ground (VSS).

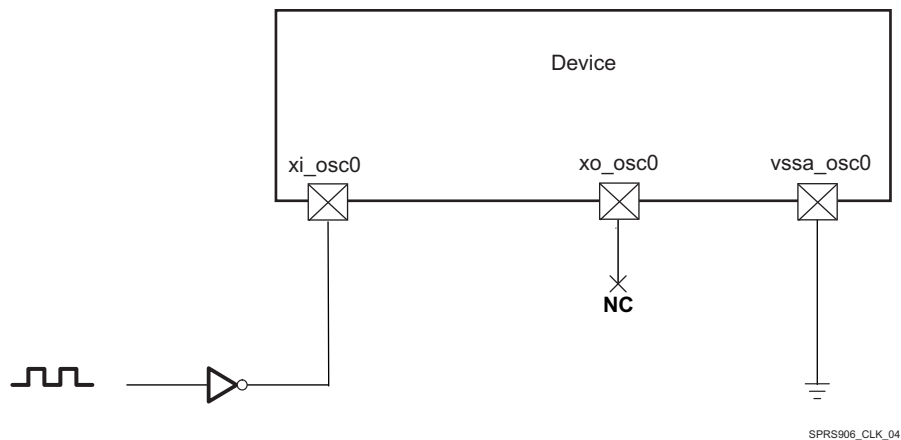

**Figure 5-14. 1.8-V LVCMOS-Compatible Clock Input**

Table 5-18 summarizes the OSC0 input clock electrical characteristics.

**Table 5-18. OSC0 Input Clock Electrical Characteristics—Bypass Mode**

NAME	DESCRIPTION	MIN	TYP	MAX	UNIT
f	Frequency	19.2, 20, 27			MHz
C <sub>IN</sub>	Input capacitance	2.184	2.384	2.584	pF
I <sub>IN</sub>	Input current (3.3V mode)	4	6	10	µA

Table 5-19 details the OSC0 input clock timing requirements.

**Table 5-19. OSC0 Input Clock Timing Requirements**

NAME	DESCRIPTION		MIN	TYP	MAX	UNIT
CK0	$1 / t_{c(xi_osc0)}$	Frequency, xi_osc0	19.2, 20, 27			MHz
CK1	$t_{w(xi_osc0)}$	Pulse duration, xi_osc0 low or high	$0.45 \times t_{c(xi_osc0)}$		$0.55 \times t_{c(xi_osc0)}$	ns
	$t_{j(xi_osc0)}$	Period jitter <sup>(1)</sup> , xi_osc0			$0.01 \times t_{c(xi_osc0)}$	ns
	$t_{R(xi_osc0)}$	Rise time, xi_osc0			5	ns
	$t_{F(xi_osc0)}$	Fall time, xi_osc0			5	ns
	$t_{f(xi_osc0)}$	Frequency accuracy <sup>(2)</sup> , xi_osc0	Ethernet and MLB not used		$\pm 200$	ppm
			Ethernet RGMII and RMII using derived clock		$\pm 50$	
			Ethernet MII using derived clock		$\pm 100$	
			MLB using derived clock		$\pm 50$	

(1) Period jitter is meant here as follows:

- The maximum value is the difference between the longest measured clock period and the expected clock period
- The minimum value is the difference between the shortest measured clock period and the expected clock period

(2) Crystal characteristics should account for tolerance+stability+aging.

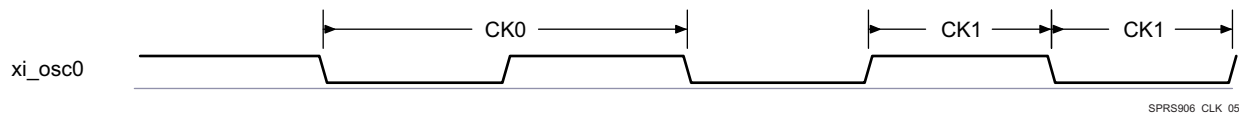

**Figure 5-15. xi\_osc0 Input Clock**

**5.10.4.1.3 Auxiliary Oscillator OSC1 Input Clock**

SYS\_CLK2 is received directly from oscillator OSC1. For more information about SYS\_CLK2 see Device TRM, Chapter: *Power, Reset, and Clock Management*.

**5.10.4.1.3.1 OSC1 External Crystal**

An external crystal is connected to the device pins. Figure 5-16 describes the crystal implementation.

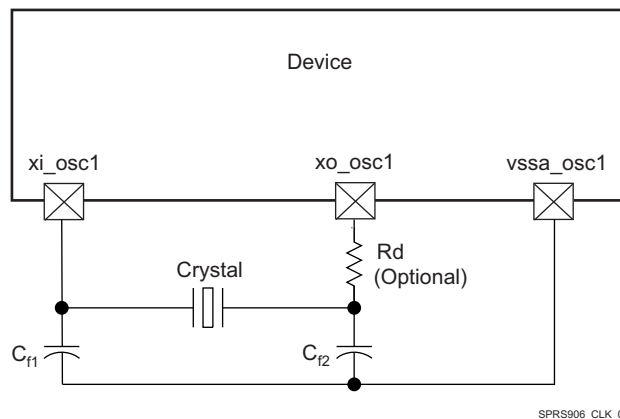

**Figure 5-16. Crystal Implementation**

**NOTE**

The load capacitors,  $C_{f1}$  and  $C_{f2}$  in Figure 5-16, should be chosen such that the below equation is satisfied.  $C_L$  in the equation is the load specified by the crystal manufacturer. All discrete components used to implement the oscillator circuit should be placed as close as possible to the associated oscillator xi\_osc1, xo\_osc1, and vssa\_osc1 pins.

$$C_L = \frac{C_{f1} C_{f2}}{(C_{f1} + C_{f2})}$$

**Figure 5-17. Load Capacitance Equation**

The crystal must be in the fundamental mode of operation and parallel resonant. Table 5-20 summarizes the required electrical constraints.

**Table 5-20. OSC1 Crystal Electrical Characteristics**

NAME	DESCRIPTION	MIN	TYP	MAX	UNIT		
$f_p$	Parallel resonance crystal frequency	Range from 19.2 to 32			MHz		
$C_{f1}$	$C_{f1}$ load capacitance for crystal parallel resonance with $C_{f1} = C_{f2}$	12		24	pF		
$C_{f2}$	$C_{f2}$ load capacitance for crystal parallel resonance with $C_{f1} = C_{f2}$	12		24	pF		
ESR( $C_{f1}, C_{f2}$ )	Crystal ESR			100	$\Omega$		
$C_O$	Crystal shunt capacitance	ESR = 30 $\Omega$	19.2 MHz $\leq f_p \leq$ 32 MHz		7	pF	
			19.2 MHz $\leq f_p \leq$ 32 MHz		5	pF	
		ESR = 50 $\Omega$	19.2 MHz $\leq f_p \leq$ 25 MHz		7	pF	
			25 MHz $< f_p \leq$ 27 MHz		5	pF	
				27 MHz $< f_p \leq$ 32 MHz		Not Supported	
		ESR = 60 $\Omega$	19.2 MHz $\leq f_p \leq$ 23 MHz		7	pF	
			23 MHz $< f_p \leq$ 25 MHz		5	pF	
			25 MHz $< f_p \leq$ 32 MHz		Not Supported		
		ESR = 80 $\Omega$	19.2 MHz $\leq f_p \leq$ 23 MHz		5	pF	
			23 MHz $\leq f_p \leq$ 25 MHz		3	pF	
			25 MHz $< f_p \leq$ 32 MHz		Not Supported		
		ESR = 100 $\Omega$	19.2 MHz $\leq f_p \leq$ 20 MHz		3	pF	
20 MHz $< f_p \leq$ 32 MHz			Not Supported				
$L_M$	Crystal motional inductance for $f_p = 20$ MHz		10.16		mH		
$C_M$	Crystal motional capacitance		3.42		fF		
$t_j(xiosc1)$	Frequency accuracy <sup>(1)</sup> , xi_osc1	Ethernet and MLB not used		$\pm 200$	ppm		
		Ethernet RGMII and RMII using derived clock		$\pm 50$			
		Ethernet MII using derived clock		$\pm 100$			
		MLB using derived clock		$\pm 50$			

(1) Crystal characteristics should account for tolerance+stability+aging.

When selecting a crystal, the system design must take into account the temperature and aging characteristics of a crystal versus the user environment and expected lifetime of the system.

Table 5-21 details the switching characteristics of the oscillator and the requirements of the input clock.

**Table 5-21. Oscillator Switching Characteristics—Crystal Mode**

NAME	DESCRIPTION	MIN	TYP	MAX	UNIT
$f_p$	Oscillation frequency	Range from 19.2 to 32			MHz

**Table 5-21. Oscillator Switching Characteristics—Crystal Mode (continued)**

NAME	DESCRIPTION	MIN	TYP	MAX	UNIT
$t_{sX}$	Start-up time			4	ms

**5.10.4.1.3.2 OSC1 Input Clock**

A 1.8-V LVCMOS-Compatible Clock Input can be used instead of the internal oscillator to provide the SYS\_CLK2 clock input to the system. The external connections to support this are shown in, [Figure 5-18](#). The xi\_osc1 pin is connected to the 1.8-V LVCMOS-Compatible clock sources. The xo\_osc1 pin is left unconnected. The vssa\_osc1 pin is connected to board ground (vss).

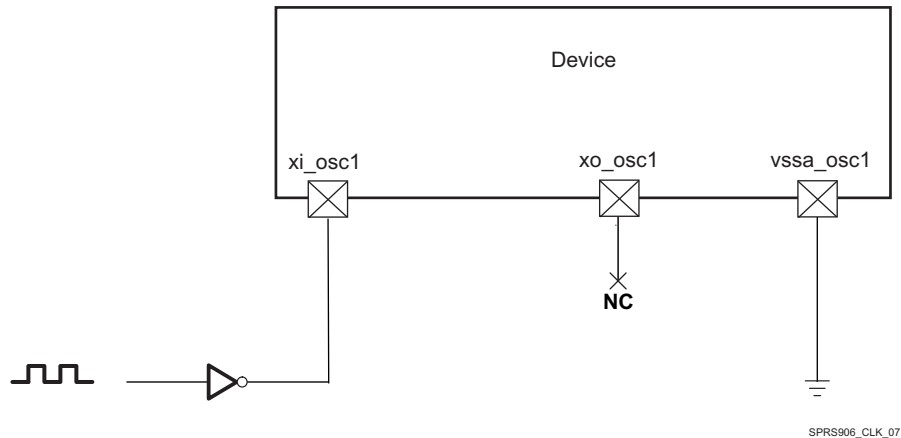
**Figure 5-18. 1.8-V LVCMOS-Compatible Clock Input**

[Table 5-22](#) summarizes the OSC1 input clock electrical characteristics.

**Table 5-22. OSC1 Input Clock Electrical Characteristics—Bypass Mode**

NAME	DESCRIPTION	MIN	TYP	MAX	UNIT
f	Frequency	Range from 12 to 38.4			MHz
$C_{IN}$	Input capacitance	2.819	3.019	3.219	pF
$I_{IN}$	Input current (3.3V mode)	4	6	10	$\mu$ A
$t_{sX}$	Start-up time <sup>(1)</sup>	See <sup>(2)</sup>			ms

(1) To switch from bypass mode to crystal or from crystal mode to bypass mode, there is a waiting time about 100  $\mu$ s; however, if the chip comes from bypass mode to crystal mode the crystal will start-up after time mentioned in [Table 5-21](#),  $t_{sX}$  parameter.

(2) Before the processor boots up and the oscillator is set to bypass mode, there is a waiting time when the internal oscillator is in application mode and receives a wave. The switching time in this case is about 100  $\mu$ s.

[Table 5-23](#) details the OSC1 input clock timing requirements.

**Table 5-23. OSC1 Input Clock Timing Requirements**

NAME	DESCRIPTION		MIN	TYP	MAX	UNIT
CK0	$1 / t_{c(xiosc1)}$	Frequency, xi_osc1	Range from 12 to 38.4			MHz
CK1	$t_{w(xiosc1)}$	Pulse duration, xi_osc1 low or high	$0.45 \times t_{c(xiosc1)}$		$0.55 \times t_{c(xiosc1)}$	ns
	$t_{j(xiosc1)}$	Period jitter <sup>(1)</sup> , xi_osc1			$0.01 \times t_{c(xiosc1)}$ <sup>(3)</sup>	ns
	$t_{R(xiosc1)}$	Rise time, xi_osc1			5	ns
	$t_{F(xiosc1)}$	Fall time, xi_osc1			5	ns



**Table 5-23. OSC1 Input Clock Timing Requirements (continued)**

NAME	DESCRIPTION	MIN	TYP	MAX	UNIT
$t_{j(xiosc1)}$	Frequency accuracy <sup>(2)</sup> , xi_osc1	Ethernet and MLB not used		±200	ppm
		Ethernet RGMII and RMII using derived clock		±50	
		Ethernet MII using derived clock		±100	
		MLB using derived clock		±50	

(1) Period jitter is meant here as follows:

- The maximum value is the difference between the longest measured clock period and the expected clock period
- The minimum value is the difference between the shortest measured clock period and the expected clock period

(2) Crystal characteristics should account for tolerance+stability+aging.

(3) The Period jitter requirement for osc1 can be relaxed to  $0.02 \times t_{c(xiosc1)}$  under the following constraints:

- a. The osc1/SYS\_CLK2 clock bypasses all device PLLs
- b. The osc1/SYS\_CLK2 clock is only used to source the DSS pixel clock outputs

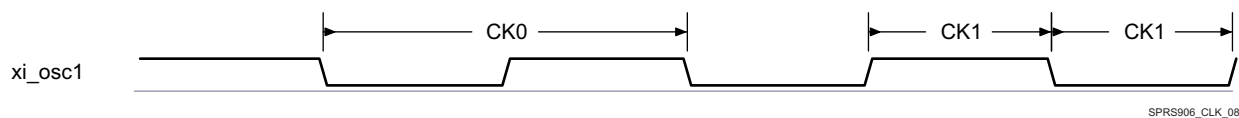

**Figure 5-19. xi\_osc1 Input Clock**

#### 5.10.4.1.4 RC On-die Oscillator Clock

**NOTE**

The OSC\_32K\_CLK clock, provided by the On-die 32K RC oscillator, inside of the SoC, is not accurate 32kHz clock.

The frequency may significantly vary with temperature and silicon characteristics.

For more information about OSC\_32K\_CLK see the Device TRM, Chapter: *Power, Reset, and Clock Management*.

#### 5.10.4.2 Output Clocks

The device provides three output clocks. Summary of these output clocks are as follows:

- clkout1 - Device Clock output 1. Can be used as a system clock for other devices. The source of the clkout1 could be either:
  - The input system clock and alternate clock (xi\_osc0 or xi\_osc1)
  - CORE clock (from CORE output)
  - 192-MHz clock (from PER DPLL output)
- clkout2 - Device Clock output 2. Can be used as a system clock for other devices. The source of the clkout2 could be either:
  - The input system clock and alternate clock (xi\_osc0 or xi\_osc1)
  - CORE clock (from CORE output)
  - 192-MHz clock (from PER DPLL output)
- clkout3 - Device Clock output 3. Can be used as a system clock for other devices. The source of the clkout3 could be either:
  - The input system clock and alternate clock (xi\_osc0 or xi\_osc1)
  - CORE clock (from CORE output)
  - 192-MHz clock (from PER DPLL output)

For more information about Output Clocks see Device TRM, Chapter: *Power, Reset, and Clock Management*.

### 5.10.4.3 DPLLs, DLLs

---

#### NOTE

For more information, see:

- Power, Reset, and Clock Management / Clock Management Functional / Internal Clock Sources / Generators / Generic DPLL Overview Section  
and
  - Display Subsystem / Display Subsystem Overview section of the Device TRM.
- 

To generate high-frequency clocks, the device supports multiple on-chip DPLLs controlled directly by the PRCM module. They are of two types: type A and type B DPLLs.

- They have their own independent power domain (each one embeds its own switch and can be controlled as an independent functional power domain)
- They are fed with ALWAYS ON system clock, with independent control per DPLL.

The different DPLLs managed by the PRCM are listed below:

- DPLL\_MPU: It supplies the MPU subsystem clocking internally.
- DPLL\_IVA: It feeds the IVA subsystem clocking.
- DPLL\_CORE: It supplies all interface clocks and also few module functional clocks.
- DPLL\_PER: It supplies several clock sources: a 192-MHz clock for the display functional clock, a 96-MHz functional clock to subsystems and peripherals.
- DPLL\_ABE: It provides clocks to various modules within the device.
- DPLL\_USB: It provides 960M clock for USB modules (USB1/2/3/4).
- DPLL\_GMAC: It supplies several clocks for the Gigabit Ethernet Switch (GMAC\_SW).
- DPLL\_DSP: It feeds the DSP Subsystem clocking.
- DPLL\_GPU: It supplies clock for the GPU Subsystem.
- DPLL\_DDR: It generates clocks for the two External Memory Interface (EMIF) controllers and their associated EMIF PHYs.
- DPLL\_PCIE\_REF: It provides reference clock for the APLL\_PCIE in PCIE Subsystem.
- APLL\_PCIE: It feeds clocks for the device Peripheral Component Interconnect Express (PCIe) controllers.

---

#### NOTE

The following DPLLs are controlled by the clock manager located in the always-on Core power domain (CM\_CORE\_AON):

- DPLL\_MPU, DPLL\_IVA, DPLL\_CORE, DPLL\_ABE, DPLL\_DDR, DPLL\_GMAC, DPLL\_PCIE\_REF, DPLL\_PER, DPLL\_USB, DPLL\_DSP, DPLL\_GPU, APLL\_PCIE\_REF.
- 

For more information on CM\_CORE\_AON and CM\_CORE or PRCM DPLLs, see the Power, Reset, and Clock Management (PRCM) chapter of the Device TRM.

The following DPLLs are not managed by the PRCM:

- DPLL\_VIDEO1; (It is controlled from DSS)
  - DPLL\_HDMI; (It is controlled from DSS)
  - DPLL\_DEBUG; (It is controlled from DEBUGSS)
  - DPLL\_USB\_OTG\_SS; (It is controlled from OCP2SCP1)
- 

#### NOTE

For more information for not controlled from PRCM DPLL's see the related chapters in TRM.

---

### 5.10.4.3.1 DPLL Characteristics

The DPLL has three relevant input clocks. One of them is the reference clock (CLKINP) used to generate the synthesized clock but can also be used as the bypass clock whenever the DPLL enters a bypass mode. It is therefore mandatory. The second one is a fast bypass clock (CLKINPULOW) used when selected as the bypass clock and is optional. The third clock (CLKINPHIF) is explained in the next paragraph.

The DPLL has three output clocks (namely CLKOUT, CLKOUTX2, and CLKOUTHIF). CLKOUT and CLKOUTX2 run at the bypass frequency whenever the DPLL enters a bypass mode. Both of them are generated from the lock frequency divided by a post-divider (namely M2 post-divider). The third clock, CLKOUTHIF, has no automatic bypass capability. It is an output of a post-divider (M3 post-divider) with the input clock selectable between the internal lock clock (Fdpll) and CLKINPHIF input of the PLL through an asynchronous multiplexing.

For more information, see the Power Reset Controller Management chapter of the Device TRM.

Table 5-24 summarizes DPLL type described in Section 5.10.4.3, *DPLLs, DLLs Specifications* introduction.

**Table 5-24. DPLL Control Type**

DPLL NAME	TYPE	CONTROLLED BY PRCM
DPLL_ABE	Table 5-25 (Type A)	Yes <sup>(1)</sup>
DPLL_CORE	Table 5-25 (Type A)	Yes <sup>(1)</sup>
DPLL_DEBUGSS	Table 5-25 (Type A)	No <sup>(2)</sup>
DPLL_DSP	Table 5-25 (Type A)	Yes <sup>(1)</sup>
DPLL_GMAC	Table 5-25 (Type A)	Yes <sup>(1)</sup>
DPLL_HDMI	Table 5-26 (Type B)	No <sup>(2)</sup>
DPLL_IVA	Table 5-25 (Type A)	Yes <sup>(1)</sup>
DPLL_MPU	Table 5-25 (Type A)	Yes <sup>(1)</sup>
DPLL_PER	Table 5-25 (Type A)	Yes <sup>(1)</sup>
APLL_PCIE	Table 5-25 (Type A)	Yes <sup>(1)</sup>
DPLL_PCIE_REF	Table 5-26 (Type B)	Yes <sup>(1)</sup>
DPLL_USB	Table 5-26 (Type B)	Yes <sup>(1)</sup>
DPLL_USB_OTG_SS	Table 5-26 (Type B)	No <sup>(2)</sup>
DPLL_VIDEO1	Table 5-25 (Type A)	No <sup>(2)</sup>
DPLL_DDR	Table 5-25 (Type A)	Yes <sup>(1)</sup>
DPLL_GPU	Table 5-25 (Type A)	Yes <sup>(1)</sup>

(1) DPLL is in the always-on domain.

(2) DPLL is not controlled by the PRCM.

Table 5-25 and Table 5-26 summarize the DPLL characteristics and assume testing over recommended operating conditions.

**Table 5-25. DPLL Type A Characteristics**

NAME	DESCRIPTION	MIN	TYP	MAX	UNIT	COMMENTS
f <sub>input</sub>	CLKINP input frequency	0.032		52	MHz	F <sub>INP</sub>
f <sub>internal</sub>	Internal reference frequency	0.15		52	MHz	REFCLK
f <sub>CLKINPHIF</sub>	CLKINPHIF input frequency	10		1400	MHz	F <sub>INPHIF</sub>
f <sub>CLKINPULOW</sub>	CLKINPULOW input frequency	0.001		600	MHz	Bypass mode: f <sub>CLKOUT</sub> = f <sub>CLKINPULOW</sub> / (M1 + 1) if ulowclken = 1 <sup>(6)</sup>
f <sub>CLKOUT</sub>	CLKOUT output frequency	20 <sup>(1)</sup>		1800 <sup>(2)</sup>	MHz	[M / (N + 1)] × F <sub>INP</sub> × [1 / M2] (in locked condition)

**Table 5-25. DPLL Type A Characteristics (continued)**

NAME	DESCRIPTION	MIN	TYP	MAX	UNIT	COMMENTS
f <sub>CLKOUTx2</sub>	CLKOUTx2 output frequency	40 <sup>(1)</sup>		2200 <sup>(2)</sup>	MHz	$2 \times [M / (N + 1)] \times F_{INP} \times [1 / M2]$ (in locked condition)
f <sub>CLKOUTHIF</sub>	CLKOUTHIF output frequency	20 <sup>(3)</sup>		1400 <sup>(4)</sup>	MHz	$F_{INPHIF} / M3$ if $clklnphifsel = 1$
		40 <sup>(3)</sup>		2200 <sup>(4)</sup>	MHz	$2 \times [M / (N + 1)] \times F_{INP} \times [1 / M3]$ if $clklnphifsel = 0$
f <sub>CLKDCOLDO</sub>	DCOCLKLDO output frequency	40		2800	MHz	$2 \times [M / (N + 1)] \times F_{INP}$ (in locked condition)
t <sub>lock</sub>	Frequency lock time			6 + 350 × REFCLK	μs	
p <sub>lock</sub>	Phase lock time			6 + 500 × REFCLK	μs	
t <sub>relock-L</sub>	Relock time—Frequency lock <sup>(5)</sup> (LP relock time from bypass)			6 + 70 × REFCLK	μs	DPLL in LP relock time: lowcurrstbby = 1
p <sub>relock-L</sub>	Relock time—Phase lock <sup>(5)</sup> (LP relock time from bypass)			6 + 120 × REFCLK	μs	DPLL in LP relock time: lowcurrstbby = 1
t <sub>relock-F</sub>	Relock time—Frequency lock <sup>(5)</sup> (fast relock time from bypass)			3.55 + 70 × REFCLK	μs	DPLL in fast relock time: lowcurrstbby = 0
p <sub>relock-F</sub>	Relock time—Phase lock <sup>(5)</sup> (fast relock time from bypass)			3.55 + 120 × REFCLK	μs	DPLL in fast relock time: lowcurrstbby = 0

(1) The minimum frequencies on CLKOUT and CLKOUTX2 are assuming M2 = 1.

For M2 > 1, the minimum frequency on these clocks will further scale down by factor of M2.

(2) The maximum frequencies on CLKOUT and CLKOUTX2 are assuming M2 = 1.

(3) The minimum frequency on CLKOUTHIF is assuming M3 = 1. For M3 > 1, the minimum frequency on this clock will further scale down by factor of M3.

(4) The maximum frequency on CLKOUTHIF is assuming M3 = 1.

(5) Relock time assumes typical operating conditions, 10°C maximum temperature drift.

(6) Bypass mode: f<sub>CLKOUT</sub> = F<sub>INP</sub> if ulowclken = 0. For more information, see the Device TRM.

**Table 5-26. DPLL Type B Characteristics**

NAME	DESCRIPTION	MIN	TYP	MAX	UNIT	COMMENTS
f <sub>input</sub>	CLKINP input clock frequency	0.62		60	MHz	F <sub>INP</sub>
f <sub>internal</sub>	REFCLK internal reference clock frequency	0.62		2.5	MHz	$[1 / (N + 1)] \times F_{INP}$
f <sub>CLKINPULOW</sub>	CLKINPULOW bypass input clock frequency	0.001		600	MHz	Bypass mode: f <sub>CLKOUT</sub> = f <sub>CLKINPULOW</sub> / (M1 + 1) if ulowclken = 1 <sup>(4)</sup>
f <sub>CLKLDOOUT</sub>	CLKOUTLDO output clock frequency	20 <sup>(1)(5)</sup>		2500 <sup>(2)(5)</sup>	MHz	$M / (N + 1) \times F_{INP} \times [1 / M2]$ (in locked condition)
f <sub>CLKOUT</sub>	CLKOUT output clock frequency	20 <sup>(1)(5)</sup>		1450 <sup>(2)(5)</sup>	MHz	$[M / (N + 1)] \times F_{INP} \times [1 / M2]$ (in locked condition)
f <sub>CLKDCOLDO</sub>	Internal oscillator (DCO) output clock frequency	750 <sup>(5)</sup>		1500 <sup>(5)</sup>	MHz	$[M / (N + 1)] \times F_{INP}$ (in locked condition)
		1250 <sup>(5)</sup>		2500 <sup>(5)</sup>	MHz	
t <sub>j</sub>	CLKOUTLDO period jitter	–2.5%		2.5%		The period jitter at the output clocks is ± 2.5% peak to peak
	CLKOUT period jitter					
	CLKDCOLDO period jitter					
t <sub>lock</sub>	Frequency lock time			350 × REFCLKs	μs	
p <sub>lock</sub>	Phase lock time			500 × REFCLKs	μs	
t <sub>relock-L</sub>	Relock time—Frequency lock <sup>(3)</sup> (LP relock time from bypass)			9 + 30 × REFCLKs	μs	

**Table 5-26. DPLL Type B Characteristics (continued)**

NAME	DESCRIPTION	MIN	TYP	MAX	UNIT	COMMENTS
Prelock-L	Relock time—Phase lock <sup>(3)</sup> (LP relock time from bypass)			9 + 125 × REFCLKs	μs	

(1) The minimum frequency on CLKOUT is assuming M2 = 1.

For M2 > 1, the minimum frequency on this clock will further scale down by factor of M2.

(2) The maximum frequency on CLKOUT is assuming M2 = 1.

(3) Relock time assumes typical operating conditions, 10°C maximum temperature drift.

(4) Bypass mode:  $f_{CLKOUT} = F_{INP}$  if ULOWCLKEN = 0. For more information, see the Device TRM.

(5) For output clocks, there are two frequency ranges according to the SELFREQDCO setting. For more information, see the Device TRM.

#### 5.10.4.3.2 DLL Characteristics

Table 5-27 summarizes the DLL characteristics and assumes testing over recommended operating conditions.

**Table 5-27. DLL Characteristics**

NAME	DESCRIPTION	MIN	TYP	MAX	UNIT
$f_{input}$	Input clock frequency (EMIF_DLL_FCLK)			333	MHz
$t_{lock}$	Lock time			50k	cycles
$t_{relock}$	Relock time (a change of the DLL frequency implies that DLL must relock)			50k	cycles

#### 5.10.4.3.3 DPLL and DLL Noise Isolation

##### NOTE

For more information on DPLL and DLL decoupling capacitor requirements, see the External Capacitors / Voltage Decoupling Capacitors / I/O and Analog Voltage Decoupling / VDDA Power Domain section.

#### 5.10.5 Recommended Clock and Control Signal Transition Behavior

All clocks and control signals **must** transition between  $V_{IH}$  and  $V_{IL}$  (or between  $V_{IL}$  and  $V_{IH}$ ) in a monotonic manner. Monotonic transitions are more easily ensured with faster switching signals. Slower input transitions are more susceptible to glitches due to noise and special care should be taken for slow input clocks.

#### 5.10.6 Peripherals

##### 5.10.6.1 Timing Test Conditions

All timing requirements and switching characteristics are valid over the recommended operating conditions unless otherwise specified.

##### 5.10.6.2 Virtual and Manual I/O Timing Modes

Some of the timings described in the following sections require the use of Virtual or Manual I/O Timing Modes. Table 5-28 provides a summary of the Virtual and Manual I/O Timing Modes across all device interfaces. The individual interface timing sections found later in this document provide the full description of each applicable Virtual and Manual I/O Timing Mode. Refer to the "Pad Configuration" section of the TRM for the procedure on implementing the Virtual and Manual Timing Modes in a system.

**Table 5-28. Modes Summary**

Virtual or Manual IO Mode Name	Data Manual Timing Mode
DPI Video Output	

**Table 5-28. Modes Summary (continued)**

Virtual or Manual IO Mode Name	Data Manual Timing Mode
No Virtual or Manual IO Timing Mode Required	DPI3 Video Output Default Timings - Rising-edge Clock Reference
<a href="#">DSS_VIRTUAL1</a>	DPI3 Video Output Default Timings - Falling-edge Clock Reference
<a href="#">VOUT2_IOSET1_MANUAL1</a>	DPI2 Video Output IOSET1 Alternate Timings
<a href="#">VOUT2_IOSET1_MANUAL2</a>	DPI2 Video Output IOSET1 Default Timings - Rising-edge Clock Reference
<a href="#">VOUT2_IOSET1_MANUAL3</a>	DPI2 Video Output IOSET1 Default Timings - Falling-edge Clock Reference
<a href="#">VOUT2_IOSET1_MANUAL4</a>	DPI2 Video Output IOSET1 MANUAL4 Timings
<a href="#">VOUT2_IOSET1_MANUAL5</a>	DPI2 Video Output IOSET1 MANUAL5 Timings
<a href="#">VOUT3_MANUAL1</a>	DPI3 Video Output Alternate Timings
<a href="#">VOUT3_MANUAL4</a>	DPI3 Video Output MANUAL4 Timings
<a href="#">VOUT3_MANUAL5</a>	DPI3 Video Output MANUAL5 Timings
<b>GPMC</b>	
No Virtual or Manual IO Timing Mode Required	GPMC Asynchronous Mode Timings and Synchronous Mode - Default Timings
<a href="#">GPMC_VIRTUAL1</a>	GPMC Synchronous Mode - Alternate Timings
<b>McASP</b>	
No Virtual or Manual IO Timing Mode Required	McASP1 Asynchronous and Synchronous Transmit Timings
<a href="#">MCASP1_VIRTUAL1_SYNC_RX</a>	See <a href="#">Table 5-72</a>
<a href="#">MCASP1_VIRTUAL2_ASYNC_RX</a>	See <a href="#">Table 5-72</a>
No Virtual or Manual IO Timing Mode Required	McASP2 Asynchronous and Synchronous Transmit Timings
<a href="#">MCASP2_VIRTUAL1_SYNC_RX_80M</a>	See <a href="#">Table 5-73</a>
<a href="#">MCASP2_VIRTUAL2_ASYNC_RX</a>	See <a href="#">Table 5-73</a>
<a href="#">MCASP2_VIRTUAL3_SYNC_RX</a>	See <a href="#">Table 5-73</a>
<a href="#">MCASP2_VIRTUAL4_ASYNC_RX_80M</a>	See <a href="#">Table 5-73</a>
No Virtual or Manual IO Timing Mode Required	McASP3 Synchronous Transmit Timings
<a href="#">MCASP3_VIRTUAL2_SYNC_RX</a>	See <a href="#">Table 5-74</a>
No Virtual or Manual IO Timing Mode Required	McASP4 Synchronous Transmit Timings
<a href="#">MCASP4_VIRTUAL1_SYNC_RX</a>	See <a href="#">Table 5-75</a>
No Virtual or Manual IO Timing Mode Required	McASP5 Synchronous Transmit Timings
<a href="#">MCASP5_VIRTUAL1_SYNC_RX</a>	See <a href="#">Table 5-76</a>
No Virtual or Manual IO Timing Mode Required	McASP6 Synchronous Transmit Timings
<a href="#">MCASP6_VIRTUAL1_SYNC_RX</a>	See <a href="#">Table 5-77</a>
No Virtual or Manual IO Timing Mode Required	McASP7 Synchronous Transmit Timings
<a href="#">MCASP7_VIRTUAL2_SYNC_RX</a>	See <a href="#">Table 5-78</a>
No Virtual or Manual IO Timing Mode Required	McASP8 Synchronous Transmit Timings
<a href="#">MCASP8_VIRTUAL1_SYNC_RX</a>	See <a href="#">Table 5-79</a>
<b>eMMC/SD/SDIO</b>	
No Virtual or Manual IO Timing Mode Required	MMC1 DS (Pad Loopback), HS (Internal Loopback and Pad Loopback), SDR12 (Internal Loopback and Pad Loopback), and SDR25 Timings (Internal Loopback and Pad Loopback) Timings
<a href="#">MMC1_VIRTUAL1</a>	MMC1 SDR50 (Pad Loopback) Timings
<a href="#">MMC1_VIRTUAL4</a>	MMC1 DS (Internal Loopback) Timings
<a href="#">MMC1_VIRTUAL5</a>	MMC1 SDR50 (Internal Loopback) Timings
<a href="#">MMC1_VIRTUAL6</a>	MMC1 DDR50 (Internal Loopback) Timings
<a href="#">MMC1_MANUAL1</a>	MMC1 DDR50 (Pad Loopback) Timings
<a href="#">MMC1_MANUAL2</a>	MMC1 SDR104 Timings
No Virtual or Manual IO Timing Mode Required	MMC2 Standard (Pad Loopback), High Speed (Pad Loopback) Timings
<a href="#">MMC2_VIRTUAL2</a>	MMC2 Standard (Internal Loopback), High Speed (Internal Loopback) Timings
<a href="#">MMC2_MANUAL1</a>	MMC2 DDR (Pad Loopback) Timings
<a href="#">MMC2_MANUAL2</a>	MMC2 DDR (Internal Loopback Manual) Timings

**Table 5-28. Modes Summary (continued)**

Virtual or Manual IO Mode Name	Data Manual Timing Mode
<a href="#">MMC2_MANUAL3</a>	MMC2 HS200 Timings
No Virtual or Manual IO Timing Mode Required	MMC3 DS, SDR12, HS, SDR25 Timings
<a href="#">MMC3_MANUAL1</a>	MMC3 SDR50 Timings
No Virtual or Manual IO Timing Mode Required	MMC4 DS, SDR12, HS, SDR25 Timings
<b>QSPI</b>	
No Virtual or Manual IO Timing Mode Required	QSPI Mode 3 Timings
<a href="#">QSPI1_MANUAL1</a>	QSPI Mode 0 Timings
<b>GMAC</b>	
No Virtual or Manual IO Timing Mode Required	GMAC MII0/1 Timings
<a href="#">GMAC_RGMII0_MANUAL1</a>	GMAC RGMII0 with Transmit Clock Internal Delay Enabled
<a href="#">GMAC_RGMII1_MANUAL1</a>	GMAC RGMII1 with Transmit Clock Internal Delay Enabled
<a href="#">GMAC_RMII0_MANUAL1</a>	GMAC RMII0 Timings
<a href="#">GMAC_RMII1_MANUAL1</a>	GMAC RMII1 Timings
<b>VIP</b>	
<a href="#">VIP_MANUAL3</a>	VIN2A (IOSET4/5/6) Rise-Edge Capture Mode Timings
<a href="#">VIP_MANUAL4</a>	VIN2B (IOSET7/8/9) Rise-Edge Capture Mode Timings
<a href="#">VIP_MANUAL5</a>	VIN2A (IOSET4/5/6) Fall-Edge Capture Mode Timings
<a href="#">VIP_MANUAL6</a>	VIN2B (IOSET7/8/9) Fall-Edge Capture Mode Timings
<a href="#">VIP_MANUAL7</a>	VIN1A (IOSET2) and VIN2B (IOSET1/10) Rise-Edge Capture Mode Timings
<a href="#">VIP_MANUAL9</a>	VIN1B (IOSET6/7) Rise-Edge Capture Mode Timings
<a href="#">VIP_MANUAL10</a>	VIN2B (IOSET2/11) Rise-Edge Capture Mode Timings
<a href="#">VIP_MANUAL11</a>	VIN2B (IOSET2/11) Fall-Edge Capture Mode Timings
<a href="#">VIP_MANUAL12</a>	VIN1A (IOSET2) and VIN2B (IOSET1/10) Fall-Edge Capture Mode Timings
<a href="#">VIP_MANUAL14</a>	VIN1B (IOSET6/7) Fall-Edge Capture Mode Timings
<a href="#">VIP_MANUAL15</a>	VIN1A (IOSET8/9/10) Rise-Edge Capture Mode Timings
<a href="#">VIP_MANUAL16</a>	VIN1A (IOSET8/9/10) Fall-Edge Capture Mode Timings
<b>HDMI, EMIF, Timers, I2C, UART, McSPI, USB, PCIe, DCAN, GPIO, PWM, JTAG, TPIU, SDMA, INTC</b>	
No Virtual or Manual IO Timing Mode Required	All Modes

### 5.10.6.3 VIP

The Device includes 1 Video Input Port (VIP).

[Table 5-29](#), [Figure 5-20](#) and [Figure 5-21](#) present timings and switching characteristics of the VIP.

#### CAUTION

The I/O timings provided in this section are valid only for VIN1 and VIN2 if signals within a single IOSET are used. The IOSETs are defined in [Table 5-30](#).

**Table 5-29. Timing Requirements for VIP <sup>(3)(4)(5)</sup>**

NO.	PARAMETER	DESCRIPTION	MIN	MAX	UNIT
V1	$t_{c}(\text{CLK})$	Cycle time, vinx_clki <sup>(3) (5)</sup>	6.06 <sup>(2)</sup>		ns
V2	$t_{w}(\text{CLKH})$	Pulse duration, vinx_clki high <sup>(3) (5)</sup>	0.45 × P <sup>(2)</sup>		ns
V3	$t_{w}(\text{CLKL})$	Pulse duration, vinx_clki low <sup>(3) (5)</sup>	0.45 × P <sup>(2)</sup>		ns
V4	$t_{su}(\text{CTL/DATA-CLK})$	Input setup time, Control (vinx_dei, vinx_vsynci, vinx_fldi, vinx_hsynci) and Data (vinx_dn) valid to vinx_clki transition <sup>(3) (4) (5)</sup>	3.11 <sup>(2)</sup>		ns

**Table 5-29. Timing Requirements for VIP <sup>(3)(4)(5)</sup> (continued)**

NO.	PARAMETER	DESCRIPTION	MIN	MAX	UNIT
V6	$t_{h(CLK-CTL/DATA)}$	Input hold time, Control (vinx_dei, vinx_vsynci, vinx_fldi, vinx_hsynci) and Data (vinx_dn) valid from vinx_clki transition <sup>(3) (4) (5)</sup>	-0.05 <sup>(2)</sup>		ns

- (1) For maximum frequency of 165 MHz.
- (2) P = vinx\_clki period.
- (3) x in vinx = 1a, 1b, 2a, 2b.
- (4) n in dn = 0 to 7 when x = 1b, 2b.  
n = 0 to 23 when x = 1a, 2a.
- (5) i in clki, dei, vsynci, hsynci and fldi = 0 or 1.

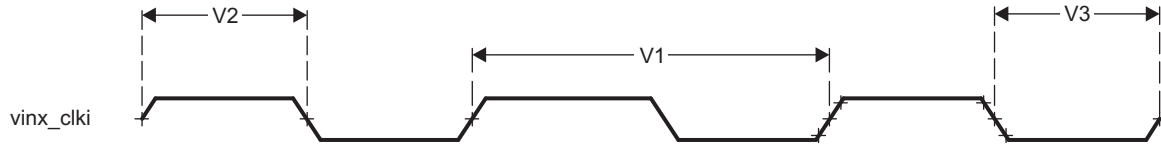

SPRS906\_TIMING\_VIP\_01

**Figure 5-20. Video Input Ports clock signal**

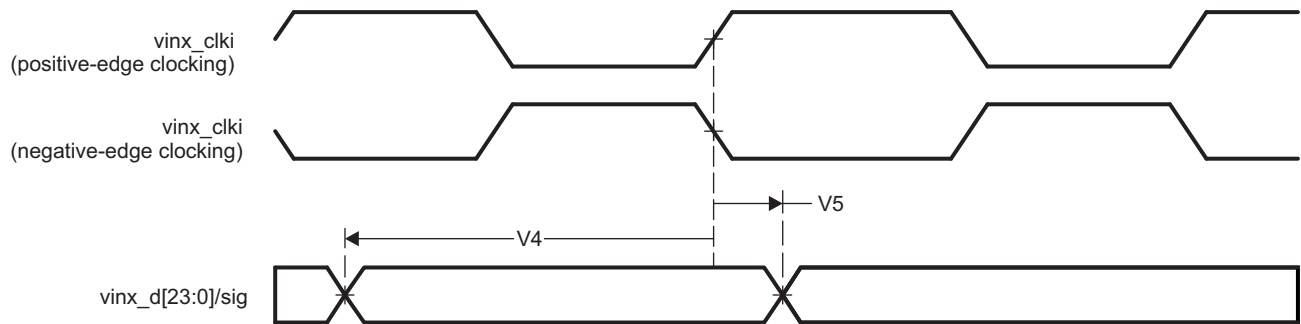

SPRS8xx\_VIP\_02

**Figure 5-21. Video Input Ports timings**



In [Table 5-30](#) and [Table 5-31](#) are presented the specific groupings of signals (IOSET) for use with vin1 and vin2.

**Table 5-30. VIN1 IOSETs**

SIGNALS	IOSET2		IOSET6 <sup>(1)</sup>		IOSET7 <sup>(1)</sup>		IOSET8		IOSET9		IOSET10	
	BALL	MUX	BALL	MUX	BALL	MUX	BALL	MUX	BALL	MUX	BALL	MUX
vin1a												
vin1a_clk0	G3	2					Y5	9	J24	7	J24	7
vin1a_hsync0	K4	2					AA4	9	B14	7	B14	7
vin1a_vsync0	H1	2					AB1	9	D14	7	D14	7
vin1a fld0	L3	2							C16	7	C16	7
vin1a_de0	J2	2					Y6	9	C17	7	C17	7
vin1a_d0	F1	2					AA1	9	J25	7	B23	7
vin1a_d1	E2	2					Y3	9	B22	7	B22	7
vin1a_d2	E1	2					W2	9	A23	7	A23	7
vin1a_d3	C1	2					AA3	9	A22	7	A22	7
vin1a_d4	D1	2					AA2	9	B21	7	B21	7
vin1a_d5	D2	2					Y4	9	A21	7	A21	7
vin1a_d6	B1	2					Y1	9	D19	7	D19	7
vin1a_d7	B2	2					Y2	9	E19	7	E19	7
vin1a_d8	C2	2							F16	7	F16	7
vin1a_d9	D3	2							E16	7	E16	7
vin1a_d10	A2	2							E17	7	E17	7
vin1a_d11	B3	2							A19	7	A19	7
vin1a_d12	C3	2							B18	7	B18	7
vin1a_d13	C4	2							B16	7	B16	7
vin1a_d14	A3	2							B17	7	B17	7
vin1a_d15	B4	2							A18	7	A18	7
vin1a_d16	M1	2										
vin1a_d17	M2	2										
vin1a_d18	L2	2										
vin1a_d19	L1	2										
vin1a_d20	K3	2										
vin1a_d21	K2	2										
vin1a_d22	J1	2										
vin1a_d23	K1	2										

Table 5-30. VIN1 IOSETs (continued)

SIGNALS	IOSET2		IOSET6 <sup>(1)</sup>		IOSET7 <sup>(1)</sup>		IOSET8		IOSET9		IOSET10	
	BALL	MUX	BALL	MUX	BALL	MUX	BALL	MUX	BALL	MUX	BALL	MUX
<b>vin1b</b>												
vin1b_clk1			L5	5	J2	6						
vin1b_hsync1			P3	5	K4	6						
vin1b_vsync1			R2	5	H1	6						
vin1b fld1			N4	5	G1	6						
vin1b_de1			P4	5	L3	6						
vin1b_d0			L6	5	M1	6						
vin1b_d1			N5	5	M2	6						
vin1b_d2			N6	5	L2	6						
vin1b_d3			T4	5	L1	6						
vin1b_d4			T5	5	K3	6						
vin1b_d5			N2	5	K2	6						
vin1b_d6			P2	5	J1	6						
vin1b_d7			N1	5	K1	6						

(1) The IOSET under this column is only applicable for pins with alternate functionality which allows either VIN1 or VIN2 signals to be mapped to the pins. These alternate functions are controlled via CTRL\_CORE\_VIP\_MUX\_SELECT register. For more information on how to use these options, please refer to Device TRM, Chapter Control Module, Section Pad Configuration Registers.

Table 5-31. VIN2 IOSETs

SIGNALS	IOSET1		IOSET2		IOSET4		IOSET5		IOSET6		IOSET7 <sup>(1)</sup>		IOSET8 <sup>(1)</sup>		IOSET9 <sup>(1)</sup>	
	BALL	MUX	BALL	MUX	BALL	MUX	BALL	MUX	BALL	MUX	BALL	MUX	BALL	MUX	BALL	MUX
<b>vin2a</b>																
vin2a_clk0					D8	0	D8	0	L5	4						
vin2a_hsync0					E8	0	E8	0	P3	4						
vin2a_vsync0					B8	0	B8	0	R2	4						
vin2a fld0					C7	0	B7	1	N4	4						
vin2a_de0					B7	0			P4	4						
vin2a_d0					C8	0	C8	0	L6	4						
vin2a_d1					B9	0	B9	0	N5	4						
vin2a_d2					A7	0	A7	0	N6	4						
vin2a_d3					A9	0	A9	0	T4	4						
vin2a_d4					A8	0	A8	0	T5	4						

Table 5-31. VIN2 IOSETs (continued)

SIGNALS	IOSET1		IOSET2		IOSET4		IOSET5		IOSET6		IOSET7 <sup>(1)</sup>		IOSET8 <sup>(1)</sup>		IOSET9 <sup>(1)</sup>	
	BALL	MUX	BALL	MUX	BALL	MUX	BALL	MUX	BALL	MUX	BALL	MUX	BALL	MUX	BALL	MUX
vin2a_d5					A11	0	A11	0	N2	4						
vin2a_d6					F10	0	F10	0	P2	4						
vin2a_d7					A10	0	A10	0	N1	4						
vin2a_d8					B10	0	B10	0	P1	4						
vin2a_d9					E10	0	E10	0	N3	4						
vin2a_d10					D10	0	D10	0	R1	4						
vin2a_d11					C10	0	C10	0	P5	4						
vin2a_d12					B11	0	B11	0								
vin2a_d13					D11	0	D11	0								
vin2a_d14					C11	0	C11	0								
vin2a_d15					B12	0	B12	0								
vin2a_d16					A12	0	A12	0								
vin2a_d17					A13	0	A13	0								
vin2a_d18					E11	0	E11	0								
vin2a_d19					F11	0	F11	0								
vin2a_d20					B13	0	B13	0								
vin2a_d21					E13	0	E13	0								
vin2a_d22					C13	0	C13	0								
vin2a_d23					D13	0	D13	0								
<b>vin2b</b>																
vin2b_clk1	L4	6	H6	4							C7	2	C7	2	AB1	4
vin2b_hsync1	B6	6	B6	6							E8	3	E8	3	Y5	4
vin2b_vsync1	A6	6	A6	6							B8	3	B8	3	Y6	4
vin2b fld1	H6	6											B7	2		
vin2b_de1	H2	6	H2	6							B7	3			AA4	4
vin2b_d0	A4	6	A4	6							D13	2	D13	2	AA1	4
vin2b_d1	E7	6	E7	6							C13	2	C13	2	Y3	4
vin2b_d2	D6	6	D6	6							E13	2	E13	2	W2	4
vin2b_d3	C5	6	C5	6							B13	2	B13	2	AA3	4
vin2b_d4	B5	6	B5	6							F11	2	F11	2	AA2	4
vin2b_d5	D7	6	D7	6							E11	2	E11	2	Y4	4
vin2b_d6	C6	6	C6	6							A13	2	A13	2	Y1	4

**Table 5-31. VIN2 IOSETs (continued)**

SIGNALS	IOSET1		IOSET2		IOSET4		IOSET5		IOSET6		IOSET7 <sup>(1)</sup>		IOSET8 <sup>(1)</sup>		IOSET9 <sup>(1)</sup>	
	BALL	MUX	BALL	MUX	BALL	MUX	BALL	MUX	BALL	MUX	BALL	MUX	BALL	MUX	BALL	MUX
vin2b_d7	A5	6	A5	6							A12	2	A12	2	Y2	4

(1) The IOSET under this column is only applicable for pins with alternate functionality which allows either VIN1 or VIN2 signals to be mapped to the pins. These alternate functions are controlled via CTRL\_CORE\_VIP\_MUX\_SELECT register. For more information on how to use these options, please refer to Device TRM, Chapter Control Module, Section Pad Configuration Registers.

**NOTE**

To configure the desired Manual IO Timing Mode the user must follow the steps described in section "Manual IO Timing Modes" of the Device TRM.

The associated registers to configure are listed in the **CFG REGISTER** column. For more information please see the *Control Module Chapter* in the Device TRM.

Manual IO Timings Modes must be used to ensure some IO timings for VIP1. See [Table 5-28 Modes Summary](#) for a list of IO timings requiring the use of Manual IO Timings Modes. See [Table 5-32 Manual Functions Mapping for VIN2A \(IOSET4/5/6\)](#) for a definition of the Manual modes.

[Table 5-32](#) lists the A\_DELAY and G\_DELAY values needed to calculate the correct values to be set in the CFG\_x registers.

**Table 5-32. Manual Functions Mapping for VIN2A (IOSET4/5/6)**

BALL	BALL NAME	VIP_MANUAL3		VIP_MANUAL5		CFG REGISTER	MUXMODE		
		A_DELAY (ps)	G_DELAY (ps)	A_DELAY (ps)	G_DELAY (ps)		0	1	4
P5	RMII_MHZ_50_CLK	2616	1379	2798	1294	CFG_RMII_MHZ_50_CLK_IN	-	-	vin2a_d11
L6	mdio_d	2558	1105	2790	954	CFG_MDIO_D_IN	-	-	vin2a_d0
L5	mdio_mclk	998	463	1029	431	CFG_MDIO_MCLK_IN	-	-	vin2a_clk0
N2	rgmii0_rxc	2658	862	2896	651	CFG_RGMII0_RXC_IN	-	-	vin2a_d5
P2	rgmii0_rxctl	2658	1628	2844	1518	CFG_RGMII0_RXCTL_IN	-	-	vin2a_d6
N4	rgmii0_rxd0	2638	1123	2856	888	CFG_RGMII0_RXD0_IN	-	-	vin2a_fld0
N3	rgmii0_rxd1	2641	1737	2804	1702	CFG_RGMII0_RXD1_IN	-	-	vin2a_d9
P1	rgmii0_rxd2	2641	1676	2801	1652	CFG_RGMII0_RXD2_IN	-	-	vin2a_d8
N1	rgmii0_rxd3	2644	1828	2807	1790	CFG_RGMII0_RXD3_IN	-	-	vin2a_d7
T4	rgmii0_txc	2638	1454	2835	1396	CFG_RGMII0_TXC_IN	-	-	vin2a_d3
T5	rgmii0_txctl	2672	1663	2831	1640	CFG_RGMII0_TXCTL_IN	-	-	vin2a_d4
R1	rgmii0_txd0	2604	1442	2764	1417	CFG_RGMII0_TXD0_IN	-	-	vin2a_d10
R2	rgmii0_txd1	2683	1598	2843	1600	CFG_RGMII0_TXD1_IN	-	-	vin2a_vsync0
P3	rgmii0_txd2	2563	1483	2816	1344	CFG_RGMII0_TXD2_IN	-	-	vin2a_hsync0

**Table 5-32. Manual Functions Mapping for VIN2A (IOSET4/5/6) (continued)**

BALL	BALL NAME	VIP_MANUAL3		VIP_MANUAL5		CFG REGISTER	MUXMODE		
		A_DELAY (ps)	G_DELAY (ps)	A_DELAY (ps)	G_DELAY (ps)		0	1	4
P4	rgmii0_txd3	2717	1461	2913	1310	CFG_RGMII0_TXD3_IN	-	-	vin2a_de0
N5	uart3_rxd	2445	1145	2743	923	CFG_UART3_RXD_IN	-	-	vin2a_d1
N6	uart3_txd	2650	1197	2842	1080	CFG_UART3_TXD_IN	-	-	vin2a_d2
D8	vin2a_clk0	0	0	0	0	CFG_VIN2A_CLK0_IN	vin2a_clk0	-	-
C8	vin2a_d0	1812	102	1936	0	CFG_VIN2A_D0_IN	vin2a_d0	-	-
B9	vin2a_d1	1701	439	2229	10	CFG_VIN2A_D1_IN	vin2a_d1	-	-
D10	vin2a_d10	1720	215	2031	0	CFG_VIN2A_D10_IN	vin2a_d10	-	-
C10	vin2a_d11	1622	0	1702	0	CFG_VIN2A_D11_IN	vin2a_d11	-	-
B11	vin2a_d12	1350	412	1819	0	CFG_VIN2A_D12_IN	vin2a_d12	-	-
D11	vin2a_d13	1613	147	1476	260	CFG_VIN2A_D13_IN	vin2a_d13	-	-
C11	vin2a_d14	1149	516	1701	0	CFG_VIN2A_D14_IN	vin2a_d14	-	-
B12	vin2a_d15	1530	450	2021	0	CFG_VIN2A_D15_IN	vin2a_d15	-	-
A12	vin2a_d16	1512	449	2044	11	CFG_VIN2A_D16_IN	vin2a_d16	-	-
A13	vin2a_d17	1293	488	1839	5	CFG_VIN2A_D17_IN	vin2a_d17	-	-
E11	vin2a_d18	2140	371	2494	0	CFG_VIN2A_D18_IN	vin2a_d18	-	-
F11	vin2a_d19	2041	275	1699	611	CFG_VIN2A_D19_IN	vin2a_d19	-	-
A7	vin2a_d2	1675	35	1736	0	CFG_VIN2A_D2_IN	vin2a_d2	-	-
B13	vin2a_d20	1972	441	2412	88	CFG_VIN2A_D20_IN	vin2a_d20	-	-
E13	vin2a_d21	1957	556	2391	161	CFG_VIN2A_D21_IN	vin2a_d21	-	-
C13	vin2a_d22	2011	433	2446	102	CFG_VIN2A_D22_IN	vin2a_d22	-	-
D13	vin2a_d23	1962	523	2395	145	CFG_VIN2A_D23_IN	vin2a_d23	-	-
A9	vin2a_d3	1457	361	1943	0	CFG_VIN2A_D3_IN	vin2a_d3	-	-
A8	vin2a_d4	1535	0	1601	0	CFG_VIN2A_D4_IN	vin2a_d4	-	-
A11	vin2a_d5	1676	271	2052	0	CFG_VIN2A_D5_IN	vin2a_d5	-	-
F10	vin2a_d6	1513	0	1571	0	CFG_VIN2A_D6_IN	vin2a_d6	-	-
A10	vin2a_d7	1616	141	1855	0	CFG_VIN2A_D7_IN	vin2a_d7	-	-
B10	vin2a_d8	1286	437	1224	618	CFG_VIN2A_D8_IN	vin2a_d8	-	-
E10	vin2a_d9	1544	265	1373	509	CFG_VIN2A_D9_IN	vin2a_d9	-	-
B7	vin2a_de0	1732	208	1949	0	CFG_VIN2A_DE0_IN	vin2a_de0	vin2a_fld0	-
C7	vin2a_fld0	1461	562	1983	151	CFG_VIN2A_FLD0_IN	vin2a_fld0	-	-
E8	vin2a_hsync0	1877	0	1943	0	CFG_VIN2A_HSYNC0_IN	vin2a_hsync0	-	-
B8	vin2a_vsync0	1566	0	1612	0	CFG_VIN2A_VSYNC0_IN	vin2a_vsync0	-	-

Manual IO Timings Modes must be used to ensure some IO timings for VIP1. See [Table 5-28 Modes Summary](#) for a list of IO timings requiring the use of Manual IO Timings Modes. See [Table 5-33 Manual Functions Mapping for VIN2B \(IOSET7/8/9\)](#) for a definition of the Manual modes.

[Table 5-33](#) lists the A\_DELAY and G\_DELAY values needed to calculate the correct values to be set in the CFG\_x registers.

**Table 5-33. Manual Functions Mapping for VIN2B (IOSET7/8/9)**

BALL	BALL NAME	VIP_MANUAL4		VIP_MANUAL6		CFG REGISTER	MUXMODE		
		A_DELAY (ps)	G_DELAY (ps)	A_DELAY (ps)	G_DELAY (ps)		2	3	4
Y5	gpio6_10	2829	884	3009	892	CFG_GPIO6_10_IN	-	-	vin2b_hsync1
Y6	gpio6_11	2648	1033	2890	1096	CFG_GPIO6_11_IN	-	-	vin2b_vsync1
Y2	mmc3_clk	2794	1074	2997	1089	CFG_MMC3_CLK_IN	-	-	vin2b_d7
Y1	mmc3_cmd	2789	1162	2959	1210	CFG_MMC3_CMD_IN	-	-	vin2b_d6
Y4	mmc3_dat0	2689	1180	2897	1269	CFG_MMC3_DAT0_IN	-	-	vin2b_d5
AA2	mmc3_dat1	2605	1219	2891	1219	CFG_MMC3_DAT1_IN	-	-	vin2b_d4
AA3	mmc3_dat2	2616	703	2947	590	CFG_MMC3_DAT2_IN	-	-	vin2b_d3
W2	mmc3_dat3	2760	1235	2931	1342	CFG_MMC3_DAT3_IN	-	-	vin2b_d2
Y3	mmc3_dat4	2757	880	2979	891	CFG_MMC3_DAT4_IN	-	-	vin2b_d1
AA1	mmc3_dat5	2688	1177	2894	1262	CFG_MMC3_DAT5_IN	-	-	vin2b_d0
AA4	mmc3_dat6	2638	1165	2894	1187	CFG_MMC3_DAT6_IN	-	-	vin2b_de1
AB1	mmc3_dat7	995	182	1202	107	CFG_MMC3_DAT7_IN	-	-	vin2b_clk1
A12	vin2a_d16	1423	0	1739	0	CFG_VIN2A_D16_IN	vin2b_d7	-	-
A13	vin2a_d17	1253	0	1568	0	CFG_VIN2A_D17_IN	vin2b_d6	-	-
E11	vin2a_d18	2080	0	2217	0	CFG_VIN2A_D18_IN	vin2b_d5	-	-
F11	vin2a_d19	1849	0	2029	0	CFG_VIN2A_D19_IN	vin2b_d4	-	-
B13	vin2a_d20	1881	50	2202	0	CFG_VIN2A_D20_IN	vin2b_d3	-	-
E13	vin2a_d21	1917	167	2313	0	CFG_VIN2A_D21_IN	vin2b_d2	-	-
C13	vin2a_d22	1955	79	2334	0	CFG_VIN2A_D22_IN	vin2b_d1	-	-
D13	vin2a_d23	1899	145	2288	0	CFG_VIN2A_D23_IN	vin2b_d0	-	-
B7	vin2a_de0	1568	261	2048	0	CFG_VIN2A_DE0_IN	vin2b_fld1	vin2b_de1	-
C7	vin2a_fld0	0	0	0	0	CFG_VIN2A_FLD0_IN	vin2b_clk1	-	-
E8	vin2a_hsync0	1793	0	2011	0	CFG_VIN2A_HSYNC0_IN	-	vin2b_hsync1	-
B8	vin2a_vsync0	1382	0	1632	0	CFG_VIN2A_VSYNC0_IN	-	vin2b_vsync1	-

Manual IO Timings Modes must be used to ensure some IO timings for VIP1. See [Table 5-28 Modes Summary](#) for a list of IO timings requiring the use of Manual IO Timings Modes. See [Table 5-34 Manual Functions Mapping for VIN1A \(IOSET2\) and VIN2B \(IOSET1/10\)](#) for a definition of the Manual modes.

[Table 5-34](#) lists the A\_DELAY and G\_DELAY values needed to calculate the correct values to be set in the CFG\_x registers.

**Table 5-34. Manual Functions Mapping for VIN1A (IOSET2) and VIN2B (IOSET1/10)**

BALL	BALL NAME	VIP_MANUAL7		VIP_MANUAL12		CFG REGISTER	MUXMODE	
		A_DELAY (ps)	G_DELAY (ps)	A_DELAY (ps)	G_DELAY (ps)		2	6
M1	gpmc_a0	3080	1792	3376	1632	CFG_GPMC_A0_IN	vin1a_d16	-
M2	gpmc_a1	2958	1890	3249	1749	CFG_GPMC_A1_IN	vin1a_d17	-
J2	gpmc_a10	3073	1653	3388	1433	CFG_GPMC_A10_IN	vin1a_de0	-
L3	gpmc_a11	3014	1784	3290	1693	CFG_GPMC_A11_IN	vin1a_fld0	-
A4	gpmc_a19	1385	0	1246	0	CFG_GPMC_A19_IN	-	vin2b_d0
L2	gpmc_a2	3041	1960	3322	1850	CFG_GPMC_A2_IN	vin1a_d18	-
E7	gpmc_a20	859	0	720	0	CFG_GPMC_A20_IN	-	vin2b_d1
D6	gpmc_a21	1465	0	1334	0	CFG_GPMC_A21_IN	-	vin2b_d2
C5	gpmc_a22	1210	0	1064	0	CFG_GPMC_A22_IN	-	vin2b_d3
B5	gpmc_a23	1111	0	954	0	CFG_GPMC_A23_IN	-	vin2b_d4
D7	gpmc_a24	1137	0	1051	0	CFG_GPMC_A24_IN	-	vin2b_d5
C6	gpmc_a25	1402	0	1283	0	CFG_GPMC_A25_IN	-	vin2b_d6
A5	gpmc_a26	1298	0	1153	0	CFG_GPMC_A26_IN	-	vin2b_d7
B6	gpmc_a27	934	0	870	0	CFG_GPMC_A27_IN	-	vin2b_hsync1
L1	gpmc_a3	3019	2145	3296	2050	CFG_GPMC_A3_IN	vin1a_d19	-
K3	gpmc_a4	3063	1981	3357	1829	CFG_GPMC_A4_IN	vin1a_d20	-
K2	gpmc_a5	3021	1954	3304	1840	CFG_GPMC_A5_IN	vin1a_d21	-
J1	gpmc_a6	3062	1716	3348	1592	CFG_GPMC_A6_IN	vin1a_d22	-
K1	gpmc_a7	3260	1889	3583	1631	CFG_GPMC_A7_IN	vin1a_d23	-
K4	gpmc_a8	3033	1702	3328	1547	CFG_GPMC_A8_IN	vin1a_hsync0	-
H1	gpmc_a9	2991	1905	3281	1766	CFG_GPMC_A9_IN	vin1a_vsync0	-
F1	gpmc_ad0	2907	1342	3181	1255	CFG_GPMC_AD0_IN	vin1a_d0	-
E2	gpmc_ad1	2858	1321	3132	1234	CFG_GPMC_AD1_IN	vin1a_d1	-
A2	gpmc_ad10	2920	1384	3223	1204	CFG_GPMC_AD10_IN	vin1a_d10	-
B3	gpmc_ad11	2719	1310	3019	1198	CFG_GPMC_AD11_IN	vin1a_d11	-
C3	gpmc_ad12	2845	1135	3160	917	CFG_GPMC_AD12_IN	vin1a_d12	-
C4	gpmc_ad13	2765	1225	3045	1119	CFG_GPMC_AD13_IN	vin1a_d13	-

**Table 5-34. Manual Functions Mapping for VIN1A (IOSET2) and VIN2B (IOSET1/10) (continued)**

BALL	BALL NAME	VIP_MANUAL7		VIP_MANUAL12		CFG REGISTER	MUXMODE	
		A_DELAY (ps)	G_DELAY (ps)	A_DELAY (ps)	G_DELAY (ps)		2	6
A3	gpmc_ad14	2845	1150	3153	952	CFG_GPMC_AD14_IN	vin1a_d14	-
B4	gpmc_ad15	2766	1453	3044	1355	CFG_GPMC_AD15_IN	vin1a_d15	-
E1	gpmc_ad2	2951	1296	3226	1209	CFG_GPMC_AD2_IN	vin1a_d2	-
C1	gpmc_ad3	2825	1154	3121	997	CFG_GPMC_AD3_IN	vin1a_d3	-
D1	gpmc_ad4	2927	1245	3246	1014	CFG_GPMC_AD4_IN	vin1a_d4	-
D2	gpmc_ad5	2923	1251	3217	1098	CFG_GPMC_AD5_IN	vin1a_d5	-
B1	gpmc_ad6	2958	1342	3238	1239	CFG_GPMC_AD6_IN	vin1a_d6	-
B2	gpmc_ad7	2900	1244	3174	1157	CFG_GPMC_AD7_IN	vin1a_d7	-
C2	gpmc_ad8	2845	1585	3125	1482	CFG_GPMC_AD8_IN	vin1a_d8	-
D3	gpmc_ad9	2779	1343	3086	1223	CFG_GPMC_AD9_IN	vin1a_d9	-
H2	gpmc_ben0	1555	0	1425	0	CFG_GPMC_BEN0_IN	-	vin2b_de1
H6	gpmc_ben1	1501	0	1397	0	CFG_GPMC_BEN1_IN	-	vin2b_fld1
L4	gpmc_clk	0	0	0	0	CFG_GPMC_CLK_IN	-	vin2b_clk1
A6	gpmc_cs1	1192	0	1102	0	CFG_GPMC_CS1_IN	-	vin2b_vsync1
G3	gpmc_cs3	1324	374	1466	353	CFG_GPMC_CS3_IN	vin1a_clk0	-

Manual IO Timings Modes must be used to ensure some IO timings for VIP1. See [Table 5-28 Modes Summary](#) for a list of IO timings requiring the use of Manual IO Timings Modes. See [Table 5-35 Manual Functions Mapping for VIN1B \(IOSET6/7\)](#) for a definition of the Manual modes.

[Table 5-35](#) lists the A\_DELAY and G\_DELAY values needed to calculate the correct values to be set in the CFG\_x registers.

**Table 5-35. Manual Functions Mapping for VIN1B (IOSET6/7)**

BALL	BALL NAME	VIP_MANUAL9		VIP_MANUAL14		CFG REGISTER	MUXMODE	
		A_DELAY (ps)	G_DELAY (ps)	A_DELAY (ps)	G_DELAY (ps)		5	6
M1	gpmc_a0	1873	702	2202	441	CFG_GPMC_A0_IN	-	vin1b_d0
M2	gpmc_a1	1629	772	2057	413	CFG_GPMC_A1_IN	-	vin1b_d1
J2	gpmc_a10	0	0	0	0	CFG_GPMC_A10_IN	-	vin1b_clk1
L3	gpmc_a11	1851	1011	2126	856	CFG_GPMC_A11_IN	-	vin1b_de1
G1	gpmc_a12	2009	601	2289	327	CFG_GPMC_A12_IN	-	vin1b_fld1
L2	gpmc_a2	1734	898	2131	573	CFG_GPMC_A2_IN	-	vin1b_d2
L1	gpmc_a3	1757	1076	2106	812	CFG_GPMC_A3_IN	-	vin1b_d3
K3	gpmc_a4	1794	893	2164	559	CFG_GPMC_A4_IN	-	vin1b_d4
K2	gpmc_a5	1726	853	2120	523	CFG_GPMC_A5_IN	-	vin1b_d5



**Table 5-35. Manual Functions Mapping for VIN1B (IOSET6/7) (continued)**

BALL	BALL NAME	VIP_MANUAL9		VIP_MANUAL14		CFG REGISTER	MUXMODE	
		A_DELAY (ps)	G_DELAY (ps)	A_DELAY (ps)	G_DELAY (ps)		5	6
J1	gpmc_a6	1792	612	2153	338	CFG_GPMC_A6_IN	-	vin1b_d6
K1	gpmc_a7	2117	610	2389	304	CFG_GPMC_A7_IN	-	vin1b_d7
K4	gpmc_a8	1758	653	2140	308	CFG_GPMC_A8_IN	-	vin1b_hsync1
H1	gpmc_a9	1705	899	2067	646	CFG_GPMC_A9_IN	-	vin1b_vsync1
L6	mdio_d	1945	671	2265	414	CFG_MDIO_D_IN	vin1b_d0	-
L5	mdio_mclk	255	119	337	0	CFG_MDIO_MCLK_IN	vin1b_clk1	-
N2	rgmii0_rxc	2057	909	2341	646	CFG_RGMII0_RXC_IN	vin1b_d5	-
P2	rgmii0_rxctl	2121	1139	2323	988	CFG_RGMII0_RXCTL_IN	vin1b_d6	-
N4	rgmii0_rxd0	2070	655	2336	340	CFG_RGMII0_RXD0_IN	vin1b_fld1	-
N1	rgmii0_rxd3	2092	1357	2306	1216	CFG_RGMII0_RXD3_IN	vin1b_d7	-
T4	rgmii0_txc	2088	1205	2328	1079	CFG_RGMII0_TXC_IN	vin1b_d3	-
T5	rgmii0_txctl	2143	1383	2312	1311	CFG_RGMII0_TXCTL_IN	vin1b_d4	-
R2	rgmii0_txd1	2078	1189	2324	1065	CFG_RGMII0_TXD1_IN	vin1b_vsync1	-
P3	rgmii0_txd2	1928	1125	2306	763	CFG_RGMII0_TXD2_IN	vin1b_hsync1	-
P4	rgmii0_txd3	2255	971	2401	846	CFG_RGMII0_TXD3_IN	vin1b_de1	-
N5	uart3_rxd	1829	747	2220	400	CFG_UART3_RXD_IN	vin1b_d1	-
N6	uart3_txd	2030	837	2324	568	CFG_UART3_TXD_IN	vin1b_d2	-

Manual IO Timings Modes must be used to ensure some IO timings for VIP1. See [Table 5-28 Modes Summary](#) for a list of IO timings requiring the use of Manual IO Timings Modes. See [Table 5-36 Manual Functions Mapping for VIN2B \(IOSET2/11\)](#) for a definition of the Manual modes.

[Table 5-36](#) lists the A\_DELAY and G\_DELAY values needed to calculate the correct values to be set in the CFG\_x registers.

**Table 5-36. Manual Functions Mapping for VIN2B (IOSET2/11)**

BALL	BALL NAME	VIP_MANUAL10		VIP_MANUAL11		CFG REGISTER	MUXMODE	
		A_DELAY (ps)	G_DELAY (ps)	A_DELAY (ps)	G_DELAY (ps)		4	6
A4	gpmc_a19	1600	943	2023	477	CFG_GPMC_A19_IN	-	vin2b_d0
E7	gpmc_a20	1440	621	1875	136	CFG_GPMC_A20_IN	-	vin2b_d1
D6	gpmc_a21	1602	1066	2021	604	CFG_GPMC_A21_IN	-	vin2b_d2
C5	gpmc_a22	1395	983	1822	519	CFG_GPMC_A22_IN	-	vin2b_d3
B5	gpmc_a23	1571	716	2045	200	CFG_GPMC_A23_IN	-	vin2b_d4
D7	gpmc_a24	1463	832	1893	396	CFG_GPMC_A24_IN	-	vin2b_d5
C6	gpmc_a25	1426	1166	1842	732	CFG_GPMC_A25_IN	-	vin2b_d6

**Table 5-36. Manual Functions Mapping for VIN2B (IOSET2/11) (continued)**

BALL	BALL NAME	VIP_MANUAL10		VIP_MANUAL11		CFG REGISTER	MUXMODE	
		A_DELAY (ps)	G_DELAY (ps)	A_DELAY (ps)	G_DELAY (ps)		4	6
A5	gpmc_a26	1362	1094	1797	584	CFG_GPMC_A26_IN	-	vin2b_d7
B6	gpmc_a27	1283	809	1760	338	CFG_GPMC_A27_IN	-	vin2b_hsync1
H2	gpmc_ben0	1978	780	2327	389	CFG_GPMC_BEN0_IN	-	vin2b_de1
H6	gpmc_ben1	0	0	0	0	CFG_GPMC_BEN1_IN	vin2b_clk1	-
A6	gpmc_cs1	1411	982	1857	536	CFG_GPMC_CS1_IN	-	vin2b_vsync1

Manual IO Timings Modes must be used to ensure some IO timings for VIP1. See [Table 5-28 Modes Summary](#) for a list of IO timings requiring the use of Manual IO Timings Modes. See [Table 5-37 Manual Functions Mapping for VIN1A \(IOSET8/9/10\)](#) for a definition of the Manual modes.

[Table 5-37](#) lists the A\_DELAY and G\_DELAY values needed to calculate the correct values to be set in the CFG\_x registers.

**Table 5-37. Manual Functions Mapping for VIN1A (IOSET8/9/10)**

BALL	BALL NAME	VIP_MANUAL15		VIP_MANUAL16		CFG REGISTER	MUXMODE	
		A_DELAY (ps)	G_DELAY (ps)	A_DELAY (ps)	G_DELAY (ps)		7	9
Y5	gpio6_10	2131	2198	2170	2180	CFG_GPIO6_10_IN	-	vin1a_clk0
Y6	gpio6_11	3720	2732	4106	2448	CFG_GPIO6_11_IN	-	vin1a_de0
C16	mcasp1_aclkx	2447	0	3042	0	CFG_MCASP1_ACLKX_IN	vin1a_fid0	-
D14	mcasp1_axr0	3061	0	3380	292	CFG_MCASP1_AXR0_IN	vin1a_vsync0	-
B14	mcasp1_axr1	3113	0	3396	304	CFG_MCASP1_AXR1_IN	vin1a_hsync0	-
B16	mcasp1_axr10	2803	0	3362	0	CFG_MCASP1_AXR10_IN	vin1a_d13	-
B18	mcasp1_axr11	3292	0	3357	546	CFG_MCASP1_AXR11_IN	vin1a_d12	-
A19	mcasp1_axr12	2854	0	3145	320	CFG_MCASP1_AXR12_IN	vin1a_d11	-
E17	mcasp1_axr13	2813	0	3229	196	CFG_MCASP1_AXR13_IN	vin1a_d10	-
E16	mcasp1_axr14	2471	0	3053	0	CFG_MCASP1_AXR14_IN	vin1a_d9	-
F16	mcasp1_axr15	2815	0	3225	201	CFG_MCASP1_AXR15_IN	vin1a_d8	-
A18	mcasp1_axr8	2965	0	3427	83	CFG_MCASP1_AXR8_IN	vin1a_d15	-
B17	mcasp1_axr9	3082	0	3253	440	CFG_MCASP1_AXR9_IN	vin1a_d14	-
C17	mcasp1_fsx	2898	0	3368	139	CFG_MCASP1_FSX_IN	vin1a_de0	-
E19	mcasp2_aclkx	2413	0	2972	0	CFG_MCASP2_ACLKX_IN	vin1a_d7	-
A21	mcasp2_axr2	2478	0	3062	0	CFG_MCASP2_AXR2_IN	vin1a_d5	-
B21	mcasp2_axr3	2806	0	3175	242	CFG_MCASP2_AXR3_IN	vin1a_d4	-
D19	mcasp2_fsx	2861	78	2936	599	CFG_MCASP2_FSX_IN	vin1a_d6	-
A22	mcasp3_aclkx	1583	0	1878	0	CFG_MCASP3_ACLKX_IN	vin1a_d3	-

**Table 5-37. Manual Functions Mapping for VIN1A (IOSET8/9/10) (continued)**

BALL	BALL NAME	VIP_MANUAL15		VIP_MANUAL16		CFG REGISTER	MUXMODE	
		A_DELAY (ps)	G_DELAY (ps)	A_DELAY (ps)	G_DELAY (ps)		7	9
B22	mcasp3_axr0	2873	0	3109	375	CFG_MCASP3_AXR0_IN	vin1a_d1	-
B23	mcasp3_axr1	1625	1400	2072	1023	CFG_MCASP3_AXR1_IN	vin1a_d0	-
A23	mcasp3_fsx	2792	0	3146	257	CFG_MCASP3_FSX_IN	vin1a_d2	-
Y2	mmc3_clk	3907	2744	4260	2450	CFG_MMC3_CLK_IN	-	vin1a_d7
Y1	mmc3_cmd	3892	2768	4242	2470	CFG_MMC3_CMD_IN	-	vin1a_d6
Y4	mmc3_dat0	3786	2765	4156	2522	CFG_MMC3_DAT0_IN	-	vin1a_d5
AA2	mmc3_dat1	3673	2961	4053	2667	CFG_MMC3_DAT1_IN	-	vin1a_d4
AA3	mmc3_dat2	3818	2447	4209	2096	CFG_MMC3_DAT2_IN	-	vin1a_d3
W2	mmc3_dat3	3902	2903	4259	2672	CFG_MMC3_DAT3_IN	-	vin1a_d2
Y3	mmc3_dat4	3905	2622	4259	2342	CFG_MMC3_DAT4_IN	-	vin1a_d1
AA1	mmc3_dat5	3807	2824	4167	2595	CFG_MMC3_DAT5_IN	-	vin1a_d0
AA4	mmc3_dat6	3724	2818	4123	2491	CFG_MMC3_DAT6_IN	-	vin1a_hsync0
AB1	mmc3_dat7	3775	2481	4159	2161	CFG_MMC3_DAT7_IN	-	vin1a_vsync0
J25	xref_clk0	1971	0	2472	0	CFG_XREF_CLK0_IN	vin1a_d0	-
J24	xref_clk1	0	192	0	603	CFG_XREF_CLK1_IN	vin1a_clk0	-

#### 5.10.6.4 DSS

Two Display Parallel Interfaces (DPI) channels are available in DSS named DPI Video Output 2 and DPI Video Output 3.

#### NOTE

The DPI Video Output  $i$  ( $i = 2, 3$ ) interface is also referred to as VOUT $i$ .

Every VOUT interface consists of:

- 24-bit data bus (data[23:0])
- Horizontal synchronization signal (HSYNC)
- Vertical synchronization signal (VSYNC)
- Data enable (DE)
- Field ID (FID)
- Pixel clock (CLK)

#### NOTE

For more information, see the Display Subsystem chapter of the Device TRM.

#### CAUTION

The I/O Timings provided in this section are valid only if signals within a single IOSET are used. The IOSETs are defined in [Table 5-42](#).

#### CAUTION

The I/O Timings provided in this section are valid only for some DSS usage modes when the corresponding Virtual I/O Timings or Manual I/O Timings are configured as described in the tables found in this section.

#### CAUTION

All pads/balls configured as vout $i$ \_\* signals must be programmed to use slow slew rate by setting the corresponding CTRL\_CORE\_PAD\_\*[SLEWCONTROL] register field to SLOW (0b1).

[Table 5-38](#), [Table 5-39](#) and [Figure 5-22](#) assume testing over the recommended operating conditions and electrical characteristic conditions.

**Table 5-38. DPI Video Output  $i$  ( $i = 2, 3$ ) Default Switching Characteristics<sup>(1)(2)</sup>**

NO.	PARAMETER	DESCRIPTION	MODE	MIN	MAX	UNIT
D1	$t_{c(\text{clk})}$	Cycle time, output pixel clock vout $i$ _clk	DPI2/3	11.76		ns
D2	$t_{w(\text{clkL})}$	Pulse duration, output pixel clock vout $i$ _clk low		$P \times 0.5 - 1$ <sup>(1)</sup>		ns
D3	$t_{w(\text{clkH})}$	Pulse duration, output pixel clock vout $i$ _clk high		$P \times 0.5 - 1$ <sup>(1)</sup>		ns

**Table 5-38. DPI Video Output i (i = 2, 3) Default Switching Characteristics<sup>(1)(2)</sup> (continued)**

NO.	PARAMETER	DESCRIPTION	MODE	MIN	MAX	UNIT
D5	$t_{d(\text{clk-ctIV})}$	Delay time, output pixel clock $vout_i\_clk$ transition to output data $vout_i\_d[23:0]$ valid	DPI2 (vin2a_fld0 clock reference)	-2.5	2.5	ns
D6	$t_{d(\text{clk-dV})}$	Delay time, output pixel clock $vout_i\_clk$ transition to output control signals $vout_i\_vsync$ , $vout_i\_hsync$ , $vout_i\_de$ , and $vout_i\_fld$ valid	DPI2 (vin2a_fld0 clock reference)	-2.5	2.5	ns
D5	$t_{d(\text{clk-ctIV})}$	Delay time, output pixel clock $vout_i\_clk$ transition to output data $vout_i\_d[23:0]$ valid	DPI3	-2.5	2.5	ns
D6	$t_{d(\text{clk-dV})}$	Delay time, output pixel clock $vout_i\_clk$ transition to output control signals $vout_i\_vsync$ , $vout_i\_hsync$ , $vout_i\_de$ , and $vout_i\_fld$ valid	DPI3	-2.5	2.5	ns

(1) P = output  $vout_i\_clk$  period in ns.

(2) All pads/balls configured as  $vout_i\_*$  signals must be programmed to use slow slew rate by setting the corresponding CTRL\_CORE\_PAD\_\*[SLEWCONTROL] register field to SLOW (0b1).

(3) SERDES transceivers may be sensitive to the jitter profile of  $vout_i\_clk$ . See Application Note [Optimizing DRA7xx and TDA2xx Processors for Use With Video Display SerDes](#) for additional guidance.

**Table 5-39. DPI Video Output i (i = 2, 3) Alternate Switching Characteristics<sup>(2)</sup>**

NO.	PARAMETER	DESCRIPTION	MODE	MIN	MAX	UNIT
D1	$t_{c(\text{clk})}$	Cycle time, output pixel clock $vout_i\_clk$	DPI2/3	6.06		ns
D2	$t_{w(\text{clkL})}$	Pulse duration, output pixel clock $vout_i\_clk$ low		$P \times 0.5 - 1$ <sup>(1)</sup>		ns
D3	$t_{w(\text{clkH})}$	Pulse duration, output pixel clock $vout_i\_clk$ high		$P \times 0.5 - 1$ <sup>(1)</sup>		ns
D5	$t_{d(\text{clk-ctIV})}$	Delay time, output pixel clock $vout_i\_clk$ transition to output data $vout_i\_d[23:0]$ valid	DPI2 (vin2a_fld0 clock reference)	1.51	4.55	ns
D6	$t_{d(\text{clk-dV})}$	Delay time, output pixel clock $vout_i\_clk$ transition to output control signals $vout_i\_vsync$ , $vout_i\_hsync$ , $vout_i\_de$ , and $vout_i\_fld$ valid	DPI2 (vin2a_fld0 clock reference)	1.51	4.55	ns
D5	$t_{d(\text{clk-ctIV})}$	Delay time, output pixel clock $vout_i\_clk$ transition to output data $vout_i\_d[23:0]$ valid	DPI3	1.51	4.55	ns
D6	$t_{d(\text{clk-dV})}$	Delay time, output pixel clock $vout_i\_clk$ transition to output control signals $vout_i\_vsync$ , $vout_i\_hsync$ , $vout_i\_de$ , and $vout_i\_fld$ valid	DPI3	1.51	4.55	ns

(1) P = output  $vout_i\_clk$  period in ns.

(2) All pads/balls configured as  $vout_i\_*$  signals must be programmed to use slow slew rate by setting the corresponding CTRL\_CORE\_PAD\_\*[SLEWCONTROL] register field to SLOW (0b1).

(3) SERDES transceivers may be sensitive to the jitter profile of  $vout_i\_clk$ . See Application Note [Optimizing DRA7xx and TDA2xx Processors for Use With Video Display SerDes](#) for additional guidance.

**Table 5-40. DPI Video Output i (i = 2, 3) MANUAL4 Switching Characteristics<sup>(2)</sup>**

NO.	PARAMETER	DESCRIPTION	MODE	MIN	MAX	UNIT
D1	$t_{c(\text{clk})}$	Cycle time, output pixel clock $vout_i\_clk$	DPI2/3	6.06 <sup>(3)</sup>		ns
D2	$t_{w(\text{clkL})}$	Pulse duration, output pixel clock $vout_i\_clk$ low		$P \times 0.5 - 1$ <sup>(1)</sup>		ns
D3	$t_{w(\text{clkH})}$	Pulse duration, output pixel clock $vout_i\_clk$ high		$P \times 0.5 - 1$ <sup>(1)</sup>		ns
D5	$t_{d(\text{clk-ctIV})}$	Delay time, output pixel clock $vout_i\_clk$ transition to output data $vout_i\_d[23:0]$ valid	DPI1	2.85	5.56	ns
D6	$t_{d(\text{clk-dV})}$	Delay time, output pixel clock $vout_i\_clk$ transition to output control signals $vout_i\_vsync$ , $vout_i\_hsync$ , $vout_i\_de$ , and $vout_i\_fld$ valid	DPI1	2.85	5.56	ns
D5	$t_{d(\text{clk-ctIV})}$	Delay time, output pixel clock $vout_i\_clk$ transition to output data $vout_i\_d[23:0]$ valid	DPI2 (vin2a_fld0 clock reference)	2.85	5.56	ns

**Table 5-40. DPI Video Output i (i = 2, 3) MANUAL4 Switching Characteristics <sup>(2)</sup> (continued)**

NO.	PARAMETER	DESCRIPTION	MODE	MIN	MAX	UNIT
D6	$t_{d(\text{clk-dV})}$	Delay time, output pixel clock vouti_clk transition to output control signals vouti_vsync, vouti_hsync, vouti_de, and vouti_fld valid	DPI2 (vin2a_fld0 clock reference)	2.85	5.56	ns
D5	$t_{d(\text{clk-ctlV})}$	Delay time, output pixel clock vouti_clk transition to output data vouti_d[23:0] valid	DPI2 (xref_clk2 clock reference)	2.85	5.56	ns
D6	$t_{d(\text{clk-dV})}$	Delay time, output pixel clock vouti_clk transition to output control signals vouti_vsync, vouti_hsync, vouti_de, and vouti_fld valid	DPI2 (xref_clk2 clock reference)	2.85	5.56	ns
D5	$t_{d(\text{clk-ctlV})}$	Delay time, output pixel clock vouti_clk transition to output data vouti_d[23:0] valid	DPI3	2.85	5.56	ns
D6	$t_{d(\text{clk-dV})}$	Delay time, output pixel clock vouti_clk transition to output control signals vouti_vsync, vouti_hsync, vouti_de, and vouti_fld valid	DPI3	2.85	5.56	ns

(1) P = output vouti\_clk period in ns.

(2) All pads/balls configured as vouti\_\* signals must be programmed to use slow slew rate by setting the corresponding CTRL\_CORE\_PAD\_\*[SLEWCONTROL] register field to SLOW (0b1).

(3) SERDES transceivers may be sensitive to the jitter profile of vouti\_clk. See Application Note [Optimizing DRA7xx and TDA2xx Processors for Use With Video Display SerDes](#) for additional guidance.

**Table 5-41. DPI Video Output i (i = 2, 3) MANUAL5 Switching Characteristics <sup>(2)</sup>**

NO.	PARAMETER	DESCRIPTION	MODE	MIN	MAX	UNIT
D1	$t_{c(\text{clk})}$	Cycle time, output pixel clock vouti_clk	DPI2/3	6.06 <sup>(3)</sup>		ns
D2	$t_{w(\text{clkL})}$	Pulse duration, output pixel clock vouti_clk low		P*0.5-1 <sup>(1)</sup>		ns
D3	$t_{w(\text{clkH})}$	Pulse duration, output pixel clock vouti_clk high		P*0.5-1 <sup>(1)</sup>		ns
D5	$t_{d(\text{clk-ctlV})}$	Delay time, output pixel clock vouti_clk transition to output data vouti_d[23:0] valid	DPI1	3.55	6.61	ns
D6	$t_{d(\text{clk-dV})}$	Delay time, output pixel clock vouti_clk transition to output control signals vouti_vsync, vouti_hsync, vouti_de, and vouti_fld valid	DPI1	3.55	6.61	ns
D5	$t_{d(\text{clk-ctlV})}$	Delay time, output pixel clock vouti_clk transition to output data vouti_d[23:0] valid	DPI2 (vin2a_fld0 clock reference)	3.55	6.61	ns
D6	$t_{d(\text{clk-dV})}$	Delay time, output pixel clock vouti_clk transition to output control signals vouti_vsync, vouti_hsync, vouti_de, and vouti_fld valid	DPI2 (vin2a_fld0 clock reference)	3.55	6.61	ns
D5	$t_{d(\text{clk-ctlV})}$	Delay time, output pixel clock vouti_clk transition to output data vouti_d[23:0] valid	DPI2 (xref_clk2 clock reference)	3.55	6.61	ns
D6	$t_{d(\text{clk-dV})}$	Delay time, output pixel clock vouti_clk transition to output control signals vouti_vsync, vouti_hsync, vouti_de, and vouti_fld valid	DPI2 (xref_clk2 clock reference)	3.55	6.61	ns
D5	$t_{d(\text{clk-ctlV})}$	Delay time, output pixel clock vouti_clk transition to output data vouti_d[23:0] valid	DPI3	3.55	6.61	ns
D6	$t_{d(\text{clk-dV})}$	Delay time, output pixel clock vouti_clk transition to output control signals vouti_vsync, vouti_hsync, vouti_de, and vouti_fld valid	DPI3	3.55	6.61	ns

- (1) P = output vouti\_clk period in ns.
- (2) All pads/balls configured as vouti\_\* signals must be programmed to use slow slew rate by setting the corresponding CTRL\_CORE\_PAD\_\*[SLEWCONTROL] register field to SLOW (0b1).
- (3) SERDES transceivers may be sensitive to the jitter profile of vouti\_clk. See Application Note [Optimizing DRA7xx and TDA2xx Processors for Use With Video Display SerDes](#) for additional guidance.

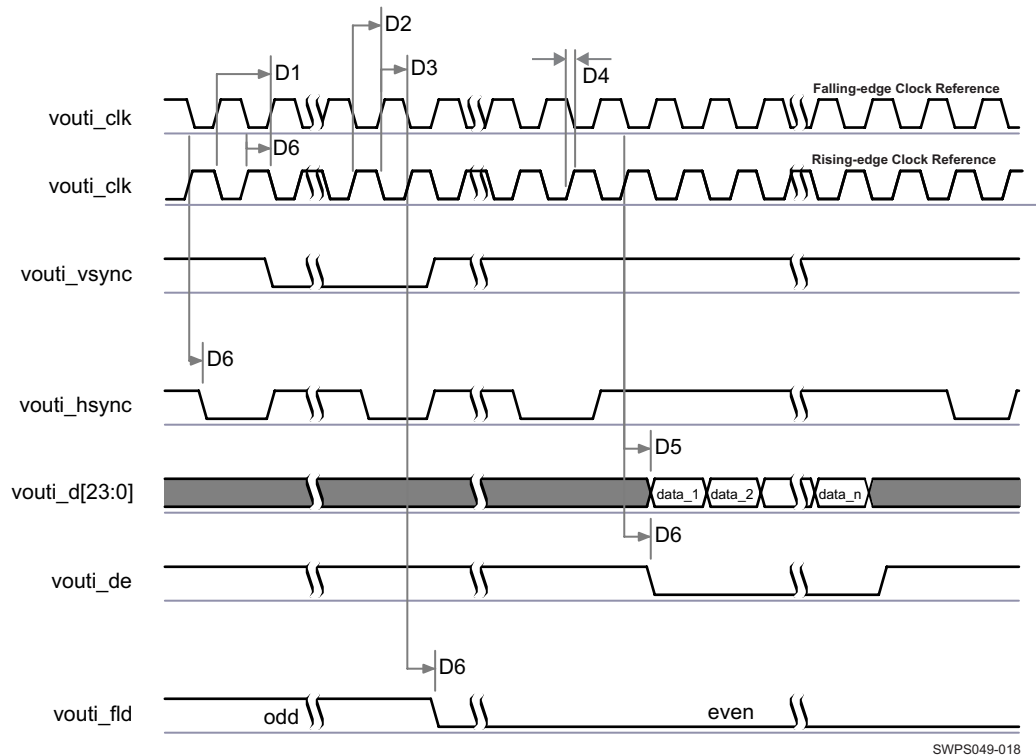

**Figure 5-22. DPI Video Output<sup>(1)(2)(3)</sup>**

- (1) The configuration of assertion of the data can be programmed on the falling or rising edge of the pixel clock.
- (2) The polarity and the pulse width of vouti\_hsync and vouti\_vsync are programmable, refer to the DSS section of the device TRM.
- (3) The vouti\_clk frequency can be configured, refer to the DSS section of the device TRM.

In [Table 5-42](#) are presented the specific groupings of signals (IOSET) for use with VOUT2.

**Table 5-42. VOUT2 IOSETs**

SIGNALS	IOSET1	
	BALL	MUX
vout2_d23	C8	4
vout2_d22	B9	4
vout2_d21	A7	4
vout2_d20	A9	4
vout2_d19	A8	4
vout2_d18	A11	4
vout2_d17	F10	4
vout2_d16	A10	4
vout2_d15	B10	4
vout2_d14	E10	4
vout2_d13	D10	4
vout2_d12	C10	4
vout2_d11	B11	4

**Table 5-42. VOUT2 IOSETs (continued)**

SIGNALS	IOSET1	
	BALL	MUX
vout2_d10	D11	4
vout2_d9	C11	4
vout2_d8	B12	4
vout2_d7	A12	4
vout2_d6	A13	4
vout2_d5	E11	4
vout2_d4	F11	4
vout2_d3	B13	4
vout2_d2	E13	4
vout2_d1	C13	4
vout2_d0	D13	4
vout2_vsync	B8	4
vout2_hsync	E8	4
vout2_clk	C7	4
vout2_fld	D8	4
vout2_de	B7	4

**NOTE**

To configure the desired virtual mode the user must set MODESELECT bit and DELAYMODE bitfield for each corresponding pad control register.

The pad control registers are presented in [Table 4-27](#) and described in Device TRM, *Control Module Chapter*.

Virtual IO Timings Modes must be used to ensure some IO timings for VOUT3. See [Table 5-28 Modes Summary](#) for a list of IO timings requiring the use of Virtual IO Timings Modes. See [Table 5-43 Virtual Functions Mapping for VOUT3](#) for a definition of the Virtual modes.

[Table 5-43](#) presents the values for DELAYMODE bitfield.

**Table 5-43. Virtual Functions Mapping for DSS VOUT3**

BALL	BALL NAME	Delay Mode Value	MUXMODE
		DSS_VIRTUAL1	3
B4	gpmc_ad15	14	vout3_d15
K4	gpmc_a8	15	vout3_hsync
D1	gpmc_ad4	14	vout3_d4
F1	gpmc_ad0	14	vout3_d0
C4	gpmc_ad13	14	vout3_d13
L2	gpmc_a2	15	vout3_d18
E2	gpmc_ad1	14	vout3_d1
K3	gpmc_a4	15	vout3_d20
J1	gpmc_a6	15	vout3_d22
A3	gpmc_ad14	14	vout3_d14
M2	gpmc_a1	15	vout3_d17
G3	gpmc_cs3	15	vout3_clk
H1	gpmc_a9	15	vout3_vsync
B3	gpmc_ad11	14	vout3_d11
B1	gpmc_ad6	14	vout3_d6



**Table 5-43. Virtual Functions Mapping for DSS VOUT3 (continued)**

BALL	BALL NAME	Delay Mode Value	MUXMODE
		DSS_VIRTUAL1	3
E1	gpmc_ad2	14	vout3_d2
C1	gpmc_ad3	14	vout3_d3
K1	gpmc_a7	15	vout3_d23
L1	gpmc_a3	15	vout3_d19
A2	gpmc_ad10	14	vout3_d10
B2	gpmc_ad7	14	vout3_d7
J2	gpmc_a10	15	vout3_de
K2	gpmc_a5	15	vout3_d21
C2	gpmc_ad8	14	vout3_d8
D2	gpmc_ad5	14	vout3_d5
M1	gpmc_a0	15	vout3_d16
C3	gpmc_ad12	14	vout3_d12
L3	gpmc_a11	15	vout3_fld
D3	gpmc_ad9	14	vout3_d9

**NOTE**

To configure the desired Manual IO Timing Mode the user must follow the steps described in section "*Manual IO Timing Modes*" of the Device TRM.

The associated registers to configure are listed in the **CFG REGISTER** column. For more information please see the *Control Module Chapter* in the Device TRM.

Manual IO Timings Modes must be used to ensure some IO timings for VOUT2. See [Table 5-28, Modes Summary](#) for a list of IO timings requiring the use of Manual IO Timings Modes. See [Table 5-44, Manual Functions Mapping for DSS VOUT2 IOSET1](#) for a definition of the Manual modes.

[Table 5-44](#) lists the A\_DELAY and G\_DELAY values needed to calculate the correct values to be set in the CFG\_x registers.

Table 5-44. Manual Functions Mapping for DSS VOUT2 IOSET1

BALL	BALL NAME	VOUT2_IOSET1_MANUAL1		VOUT2_IOSET1_MANUAL2		VOUT2_IOSET1_MANUAL3		VOUT2_IOSET1_MANUAL4		VOUT2_IOSET1_MANUAL5		CFG REGISTER	MUXMODE
		A_DELAY (ps)	G_DELAY (ps)	A_DELAY (ps)	G_DELAY (ps)	A_DELAY (ps)	G_DELAY (ps)	A_DELAY (ps)	G_DELAY (ps)	A_DELAY (ps)	G_DELAY (ps)		4
D8	vin2a_clk0	2571	0	1059	0	1025	0	4110	0	4980	0	CFG_VIN2A_CLK0_OUT	vout2_fld
C8	vin2a_d0	2124	0	589	0	577	0	3613	0	4483	0	CFG_VIN2A_D0_OUT	vout2_d23
B9	vin2a_d1	2103	0	568	0	557	0	3442	0	4312	0	CFG_VIN2A_D1_OUT	vout2_d22
D10	vin2a_d10	2091	0	557	0	545	0	3430	0	4200	0	CFG_VIN2A_D10_OUT	vout2_d13
C10	vin2a_d11	2142	0	608	0	596	0	3481	0	4251	0	CFG_VIN2A_D11_OUT	vout2_d12
B11	vin2a_d12	2920	385	1816	255	1783	276	3943	601	4713	601	CFG_VIN2A_D12_OUT	vout2_d11
D11	vin2a_d13	2776	322	1872	192	1838	213	3799	538	4669	538	CFG_VIN2A_D13_OUT	vout2_d10
C11	vin2a_d14	2904	0	1769	0	1757	0	3869	174	4739	174	CFG_VIN2A_D14_OUT	vout2_d9
B12	vin2a_d15	2670	257	1665	127	1632	148	3792	473	4662	473	CFG_VIN2A_D15_OUT	vout2_d8
A12	vin2a_d16	2814	155	1908	31	1878	43	3837	371	4707	371	CFG_VIN2A_D16_OUT	vout2_d7
A13	vin2a_d17	3002	199	1897	69	1865	89	4024	415	4894	415	CFG_VIN2A_D17_OUT	vout2_d6
E11	vin2a_d18	1893	0	358	0	347	0	3432	0	4302	0	CFG_VIN2A_D18_OUT	vout2_d5
F11	vin2a_d19	1698	0	163	0	151	0	3237	0	4007	0	CFG_VIN2A_D19_OUT	vout2_d4
A7	vin2a_d2	2193	0	658	0	646	0	3531	0	4401	0	CFG_VIN2A_D2_OUT	vout2_d21
B13	vin2a_d20	1736	0	202	0	190	0	3075	0	3945	0	CFG_VIN2A_D20_OUT	vout2_d3
E13	vin2a_d21	1636	0	101	0	89	0	3074	0	3944	0	CFG_VIN2A_D21_OUT	vout2_d2
C13	vin2a_d22	1628	0	93	0	81	0	3266	0	4036	0	CFG_VIN2A_D22_OUT	vout2_d1
D13	vin2a_d23	1538	0	0	0	0	0	2968	0	3838	0	CFG_VIN2A_D23_OUT	vout2_d0
A9	vin2a_d3	1997	0	462	0	450	0	3335	0	4205	0	CFG_VIN2A_D3_OUT	vout2_d20
A8	vin2a_d4	2528	0	993	0	982	0	3867	0	4537	0	CFG_VIN2A_D4_OUT	vout2_d19
A11	vin2a_d5	2038	0	503	0	492	0	3577	0	4347	0	CFG_VIN2A_D5_OUT	vout2_d18
F10	vin2a_d6	1746	0	211	0	200	0	3285	0	4055	0	CFG_VIN2A_D6_OUT	vout2_d17
A10	vin2a_d7	2213	0	678	0	666	0	3552	0	4272	0	CFG_VIN2A_D7_OUT	vout2_d16
B10	vin2a_d8	2268	0	733	0	721	0	3607	0	4277	0	CFG_VIN2A_D8_OUT	vout2_d15
E10	vin2a_d9	2170	0	635	0	623	0	3509	0	4379	0	CFG_VIN2A_D9_OUT	vout2_d14
B7	vin2a_de0	2102	0	568	0	556	0	3841	0	4611	0	CFG_VIN2A_DE0_OUT	vout2_de
C7	vin2a_fld0	0	983	1398	1185	1385	1202	0	994	0	994	CFG_VIN2A_FLD0_OUT	vout2_clk
E8	vin2a_hsync0	2482	0	974	0	936	0	4021	0	4891	0	CFG_VIN2A_HSYNC0_OUT	vout2_hsync
B8	vin2a_vsync0	2296	0	784	0	750	0	3935	0	4805	0	CFG_VIN2A_VSYNC0_OUT	vout2_vsync



Manual IO Timings Modes must be used to ensure some IO timings for VOUT3. See [Table 5-28, Modes Summary](#) for a list of IO timings requiring the use of Manual IO Timings Modes. See [Table 5-45, Manual Functions Mapping for DSS VOUT3](#) for a definition of the Manual modes.

[Table 5-45](#) lists the A\_DELAY and G\_DELAY values needed to calculate the correct values to be set in the CFG\_x registers.

**Table 5-45. Manual Functions Mapping for DSS VOUT3**

BALL	BALL NAME	VOUT3_MANUAL1		VOUT3_MANUAL4		VOUT3_MANUAL5		CFG REGISTER	MUXMODE 3
		A_DELAY (ps)	G_DELAY (ps)	A_DELAY (ps)	G_DELAY (ps)	A_DELAY (ps)	G_DELAY (ps)		
M1	gpmc_a0	2395	0	3909	0	4779	0	CFG_GPMC_A0_OUT	vout3_d16
M2	gpmc_a1	2412	0	3957	0	4827	0	CFG_GPMC_A1_OUT	vout3_d17
J2	gpmc_a10	2473	0	3980	0	4850	0	CFG_GPMC_A10_OUT	vout3_de
L3	gpmc_a11	2906	0	4253	0	5123	0	CFG_GPMC_A11_OUT	vout3_fld
L2	gpmc_a2	2360	0	3873	0	4743	0	CFG_GPMC_A2_OUT	vout3_d18
L1	gpmc_a3	2391	0	4112	0	4982	0	CFG_GPMC_A3_OUT	vout3_d19
K3	gpmc_a4	2626	0	4336	0	5206	0	CFG_GPMC_A4_OUT	vout3_d20
K2	gpmc_a5	2338	0	3840	0	4710	0	CFG_GPMC_A5_OUT	vout3_d21
J1	gpmc_a6	2374	0	3913	0	4783	0	CFG_GPMC_A6_OUT	vout3_d22
K1	gpmc_a7	2432	0	3947	0	4817	0	CFG_GPMC_A7_OUT	vout3_d23
K4	gpmc_a8	3155	0	4309	105	5179	105	CFG_GPMC_A8_OUT	vout3_hsync
H1	gpmc_a9	2309	0	3842	0	4712	0	CFG_GPMC_A9_OUT	vout3_vsync
F1	gpmc_ad0	2360	0	3652	0	4522	0	CFG_GPMC_AD0_OUT	vout3_d0
E2	gpmc_ad1	2420	0	3762	0	4632	0	CFG_GPMC_AD1_OUT	vout3_d1
A2	gpmc_ad10	2235	0	3456	0	4326	0	CFG_GPMC_AD10_OUT	vout3_d10
B3	gpmc_ad11	2253	0	3584	0	4454	0	CFG_GPMC_AD11_OUT	vout3_d11
C3	gpmc_ad12	1949	427	3589	0	4459	0	CFG_GPMC_AD12_OUT	vout3_d12
C4	gpmc_ad13	2318	0	3547	0	4417	0	CFG_GPMC_AD13_OUT	vout3_d13
A3	gpmc_ad14	2123	0	3302	0	4172	0	CFG_GPMC_AD14_OUT	vout3_d14
B4	gpmc_ad15	2195	29	3532	0	4402	0	CFG_GPMC_AD15_OUT	vout3_d15
E1	gpmc_ad2	2617	0	3859	0	4729	0	CFG_GPMC_AD2_OUT	vout3_d2
C1	gpmc_ad3	2350	0	3590	0	4460	0	CFG_GPMC_AD3_OUT	vout3_d3
D1	gpmc_ad4	2324	0	3534	0	4404	0	CFG_GPMC_AD4_OUT	vout3_d4
D2	gpmc_ad5	2371	0	3609	0	4479	0	CFG_GPMC_AD5_OUT	vout3_d5
B1	gpmc_ad6	2231	0	3416	0	4286	0	CFG_GPMC_AD6_OUT	vout3_d6
B2	gpmc_ad7	2440	0	3661	0	4531	0	CFG_GPMC_AD7_OUT	vout3_d7
C2	gpmc_ad8	2479	0	3714	0	4584	0	CFG_GPMC_AD8_OUT	vout3_d8
D3	gpmc_ad9	2355	0	3593	0	4463	0	CFG_GPMC_AD9_OUT	vout3_d9
G3	gpmc_cs3	0	641	0	905	0	905	CFG_GPMC_CS3_OUT	vout3_clk

### 5.10.6.5 HDMI

The High-Definition Multimedia Interface is provided for transmitting digital television audiovisual signals from DVD players, set-top boxes and other audiovisual sources to television sets, projectors and other video displays. The HDMI interface is aligned with the HDMI TMDS single stream standard v1.4a (720p @60Hz to 1080p @24Hz) and the HDMI v1.3 (1080p @60Hz): 3 data channels, plus 1 clock channel is supported (differential).

In are presented the specific groupings of signals (IOSET) for use with HDMI.

**NOTE**

For more information, see the High-Definition Multimedia Interface chapter of the device TRM

### 5.10.6.6 CSI2

**NOTE**

For more information, see the Camera Serial Interface 2 CAL Bridge chapter of the device TRM

The camera adaptation layer (CAL) deals with the processing of the pixel data coming from an external image sensor, data from memory. The CAL is a key component for the following multimedia applications: camera viewfinder, video record, and still image capture. The CAL has one serial camera interface :

- The primary serial interface (CSI2 Port A) is compliant with MIPI CSI-2 protocol with four data lanes.

#### 5.10.6.6.1 CSI-2 MIPI D-PHY

The CSI-2 port A is compliant with the MIPI D-PHY RX specification v1.00.00 and the MIPI CSI-2 specification v1.00, with 2 data differential lanes plus 1 clock differential lane in synchronous mode, double data rate:

- 1.5 Gbps (750 MHz) @OPP\_NOM for each lane.

### 5.10.6.7 EMIF

The device has a dedicated interface to DDR3 and DDR3L SDRAM. It supports JEDEC standard compliant DDR3 and DDR3L SDRAM devices with the following features:

- 16-bit or 32-bit data path to external SDRAM memory
- Memory device capacity: 128Mb, 256Mb, 512Mb, 1Gb, 2Gb, 4Gb and 8Gb devices
- One interface with associated DDR3/DDR3L PHYs

**NOTE**

For more information, see the EMIF Controller section of the Device TRM.

### 5.10.6.8 GPMC

The GPMC is the unified memory controller that interfaces external memory devices such as:

- Asynchronous SRAM-like memories and ASIC devices
- Asynchronous page mode and synchronous burst NOR flash
- NAND flash

**NOTE**

For more information, see the General-Purpose Memory Controller section of the Device TRM.

#### 5.10.6.8.1 GPMC/NOR Flash Interface Synchronous Timing

**CAUTION**

The I/O Timings provided in this section are valid only for some GPMC usage modes when the corresponding Virtual I/O Timings or Manual I/O Timings are configured as described in the tables found in this section.

Table 5-46 and Table 5-47 assume testing over the recommended operating conditions and electrical characteristic conditions below (see Figure 5-23, Figure 5-24, Figure 5-25, Figure 5-26, Figure 5-27 and Figure 5-28).

**Table 5-46. GPMC/NOR Flash Interface Timing Requirements - Synchronous Mode - Default**

NO.	PARAMETER	DESCRIPTION	MIN	MAX	UNIT
F12	$t_{su(dV-clkH)}$	Setup time, read gpmc_ad[15:0] valid before gpmc_clk high	3		ns
F13	$t_{h(clkH-dV)}$	Hold time, read gpmc_ad[15:0] valid after gpmc_clk high	1.1		ns
F21	$t_{su(waitV-clkH)}$	Setup time, gpmc_wait[1:0] valid before gpmc_clk high	2.5		ns
F22	$t_{h(clkH-waitV)}$	Hold Time, gpmc_wait[1:0] valid after gpmc_clk high	1.3		ns

**NOTE**

Wait monitoring support is limited to a WaitMonitoringTime value > 0. For a full description of wait monitoring feature, see the Device TRM.

**Table 5-47. GPMC/NOR Flash Interface Switching Characteristics - Synchronous Mode - Default**

NO.	PARAMETER	DESCRIPTION	MIN	MAX	UNIT
F0	$t_{c(clk)}$	Cycle time, output clock gpmc_clk period	11.3		ns
F2	$t_{d(clkH-nCSV)}$	Delay time, gpmc_clk rising edge to gpmc_cs[7:0] transition	F-1.7 <sup>(7)</sup>	F+4.3 <sup>(7)</sup>	ns
F3	$t_{d(clkH-nCSV)}$	Delay time, gpmc_clk rising edge to gpmc_cs[7:0] invalid	E-1.7 <sup>(6)</sup>	E+4.2 <sup>(6)</sup>	ns
F4	$t_{d(ADDV-clk)}$	Delay time, gpmc_a[27:0] address bus valid to gpmc_clk first edge	B-1.8 <sup>(3)</sup>	B+4.3 <sup>(3)</sup>	ns
F5	$t_{d(clkH-ADDIV)}$	Delay time, gpmc_clk rising edge to gpmc_a[27:0] gpmc address bus invalid	-1.8		ns
F6	$t_{d(nBEV-clk)}$	Delay time, gpmc_ben[1:0] valid to gpmc_clk rising edge	B-4.3 <sup>(3)</sup>	B+1.5 <sup>(3)</sup>	ns
F7	$t_{d(clkH-nBEIV)}$	Delay time, gpmc_clk rising edge to gpmc_ben[1:0] invalid	D-1.5 <sup>(5)</sup>	D+4.3 <sup>(5)</sup>	ns
F8	$t_{d(clkH-nADV)}$	Delay time, gpmc_clk rising edge to gpmc_advn_ale transition	G-1.3 <sup>(8)</sup>	G+4.2 <sup>(8)</sup>	ns
F9	$t_{d(clkH-nADVIV)}$	Delay time, gpmc_clk rising edge to gpmc_advn_ale invalid	D-1.3 <sup>(5)</sup>	G+4.2 <sup>(5)</sup>	ns
F10	$t_{d(clkH-nOE)}$	Delay time, gpmc_clk rising edge to gpmc_oen_ren transition	H-1.0 <sup>(9)</sup>	H+3.2 <sup>(9)</sup>	ns
F11	$t_{d(clkH-nOEIV)}$	Delay time, gpmc_clk rising edge to gpmc_oen_ren invalid	E-1.0 <sup>(6)</sup>	E+3.2 <sup>(6)</sup>	ns
F14	$t_{d(clkH-nWE)}$	Delay time, gpmc_clk rising edge to gpmc_wen transition	I-0.9 <sup>(10)</sup>	I+4.2 <sup>(10)</sup>	ns
F15	$t_{d(clkH-Data)}$	Delay time, gpmc_clk rising edge to gpmc_ad[15:0] data bus transition	J-2.1 <sup>(11)</sup>	J+4.6 <sup>(11)</sup>	ns
F17	$t_{d(clkH-nBE)}$	Delay time, gpmc_clk rising edge to gpmc_ben[1:0] transition	J-1.5 <sup>(11)</sup>	J+4.3 <sup>(11)</sup>	ns
F18	$t_{w(nCSV)}$	Pulse duration, gpmc_cs[7:0] low	A <sup>(2)</sup>		ns
F19	$t_{w(nBEV)}$	Pulse duration, gpmc_ben[1:0] low	C <sup>(4)</sup>		ns
F20	$t_{w(nADV)}$	Pulse duration, gpmc_advn_ale low	K <sup>(12)</sup>		ns
F23	$t_{d(CLK-GPIO)}$	Delay time, gpmc_clk transition to gpio6_16 transition	0.5	7.5	ns

**Table 5-48. GPMC/NOR Flash Interface Timing Requirements - Synchronous Mode - Alternate**

NO.	PARAMETER	DESCRIPTION	MIN	MAX	UNIT
F12	$t_{su(dV-clkH)}$	Setup time, read gpmc_ad[15:0] valid before gpmc_clk high	2.5		ns
F13	$t_{h(clkH-dV)}$	Hold time, read gpmc_ad[15:0] valid after gpmc_clk high	1.9		ns
F21	$t_{su(waitV-clkH)}$	Setup time, gpmc_wait[1:0] valid before gpmc_clk high	2.5		ns
F22	$t_{h(clkH-waitV)}$	Hold Time, gpmc_wait[1:0] valid after gpmc_clk high	1.9		ns

**Table 5-49. GPMC/NOR Flash Interface Switching Characteristics - Synchronous Mode - Alternate**

NO.	PARAMETER	DESCRIPTION	MIN	MAX	UNIT
F0	$t_{c(clk)}$	Cycle time, output clock gpmc_clk period <sup>(13)</sup>	15.04		ns

**Table 5-49. GPMC/NOR Flash Interface Switching Characteristics - Synchronous Mode - Alternate (continued)**

NO.	PARAMETER	DESCRIPTION	MIN	MAX	UNIT
F2	$t_{d(\text{clkH-nCSV})}$	Delay time, gpmc_clk rising edge to gpmc_cs[7:0] transition	F+0.6 <sup>(7)</sup>	F+7.0 <sup>(7)</sup>	ns
F3	$t_{d(\text{clkH-nCSIV})}$	Delay time, gpmc_clk rising edge to gpmc_cs[7:0] invalid	E+0.6 <sup>(6)</sup>	E+7.0 <sup>(6)</sup>	ns
F4	$t_{d(\text{ADV-clk})}$	Delay time, gpmc_a[27:0] address bus valid to gpmc_clk first edge	B-0.7 <sup>(3)</sup>	B+7.0 <sup>(3)</sup>	ns
F5	$t_{d(\text{clkH-ADDIV})}$	Delay time, gpmc_clk rising edge to gpmc_a[27:0] gpmc address bus invalid	-0.7		ns
F6	$t_{d(\text{nBEV-clk})}$	Delay time, gpmc_ben[1:0] valid to gpmc_clk rising edge	B-7.0	B+0.4	ns
F7	$t_{d(\text{clkH-nBEIV})}$	Delay time, gpmc_clk rising edge to gpmc_ben[1:0] invalid	D-0.4	D+7.0	ns
F8	$t_{d(\text{clkH-nADV})}$	Delay time, gpmc_clk rising edge to gpmc_advn_ale transition	G+0.7 <sup>(8)</sup>	G+6.1 <sup>(8)</sup>	ns
F9	$t_{d(\text{clkH-nADVIV})}$	Delay time, gpmc_clk rising edge to gpmc_advn_ale invalid	D+0.7 <sup>(5)</sup>	D+6.1 <sup>(5)</sup>	ns
F10	$t_{d(\text{clkH-nOE})}$	Delay time, gpmc_clk rising edge to gpmc_oen_ren transition	H+0.7 <sup>(9)</sup>	H+5.1 <sup>(9)</sup>	ns
F11	$t_{d(\text{clkH-nOEIV})}$	Delay time, gpmc_clk rising edge to gpmc_oen_ren invalid	E+0.7 <sup>(6)</sup>	E+5.1 <sup>(6)</sup>	ns
F14	$t_{d(\text{clkH-nWE})}$	Delay time, gpmc_clk rising edge to gpmc_wen transition	I+0.7 <sup>(10)</sup>	I+6.1 <sup>(10)</sup>	ns
F15	$t_{d(\text{clkH-Data})}$	Delay time, gpmc_clk rising edge to gpmc_ad[15:0] data bus transition	J-0.4 <sup>(11)</sup>	J+4.9 <sup>(11)</sup>	ns
F17	$t_{d(\text{clkH-nBE})}$	Delay time, gpmc_clk rising edge to gpmc_ben[1:0] transition	J-0.4 <sup>(11)</sup>	J+4.9 <sup>(11)</sup>	ns
F18	$t_{w(\text{nCSV})}$	Pulse duration, gpmc_cs[7:0] low	A <sup>(2)</sup>		ns
F19	$t_{w(\text{nBEV})}$	Pulse duration, gpmc_ben[1:0] low	C <sup>(4)</sup>		ns
F20	$t_{w(\text{nADV})}$	Pulse duration, gpmc_advn_ale low	K <sup>(12)</sup>		ns
F23	$t_{d(\text{CLK-GPIO})}$	Delay time, gpmc_clk transition to gpio6_16.clkout1 transition <sup>(14)</sup>	0.5	7.5	ns

(1) Total GPMC load on any signal at 3.3V must not exceed 10pF.

(2) For single read:  $A = (\text{CSRdOffTime} - \text{CSOnTime}) \times (\text{TimeParaGranularity} + 1) \times \text{GPMC\_FCLK period}$   
For burst read:  $A = (\text{CSRdOffTime} - \text{CSOnTime} + (n - 1) \times \text{PageBurstAccessTime}) \times (\text{TimeParaGranularity} + 1) \times \text{GPMC\_FCLK period}$   
For burst write:  $A = (\text{CSWrOffTime} - \text{CSOnTime} + (n - 1) \times \text{PageBurstAccessTime}) \times (\text{TimeParaGranularity} + 1) \times \text{GPMC\_FCLK period}$   
with n the page burst access number.

(3)  $B = \text{ClkActivationTime} \times \text{GPMC\_FCLK}$

(4) For single read:  $C = \text{RdCycleTime} \times (\text{TimeParaGranularity} + 1) \times \text{GPMC\_FCLK}$   
For burst read:  $C = (\text{RdCycleTime} + (n - 1) \times \text{PageBurstAccessTime}) \times (\text{TimeParaGranularity} + 1) \times \text{GPMC\_FCLK}$   
For Burst write:  $C = (\text{WrCycleTime} + (n - 1) \times \text{PageBurstAccessTime}) \times (\text{TimeParaGranularity} + 1) \times \text{GPMC\_FCLK}$  with n the page burst access number.

(5) For single read:  $D = (\text{RdCycleTime} - \text{AccessTime}) \times (\text{TimeParaGranularity} + 1) \times \text{GPMC\_FCLK}$   
For burst read:  $D = (\text{RdCycleTime} - \text{AccessTime}) \times (\text{TimeParaGranularity} + 1) \times \text{GPMC\_FCLK}$   
For burst write:  $D = (\text{WrCycleTime} - \text{AccessTime}) \times (\text{TimeParaGranularity} + 1) \times \text{GPMC\_FCLK}$

(6) For single read:  $E = (\text{CSRdOffTime} - \text{AccessTime}) \times (\text{TimeParaGranularity} + 1) \times \text{GPMC\_FCLK}$   
For burst read:  $E = (\text{CSRdOffTime} - \text{AccessTime}) \times (\text{TimeParaGranularity} + 1) \times \text{GPMC\_FCLK}$   
For burst write:  $E = (\text{CSWrOffTime} - \text{AccessTime}) \times (\text{TimeParaGranularity} + 1) \times \text{GPMC\_FCLK}$

(7) For nCS falling edge (CS activated):  
Case GpmcFCLKDivider = 0 :  
 $F = 0.5 \times \text{CSExtraDelay} \times \text{GPMC\_FCLK}$  Case GpmcFCLKDivider = 1:  
 $F = 0.5 \times \text{CSExtraDelay} \times \text{GPMC\_FCLK}$  if (ClkActivationTime and CSOnTime are odd) or (ClkActivationTime and CSOnTime are even)  
 $F = (1 + 0.5 \times \text{CSExtraDelay}) \times \text{GPMC\_FCLK}$  otherwise  
Case GpmcFCLKDivider = 2:  
 $F = 0.5 \times \text{CSExtraDelay} \times \text{GPMC\_FCLK}$  if ((CSOnTime - ClkActivationTime) is a multiple of 3)  
 $F = (1 + 0.5 \times \text{CSExtraDelay}) \times \text{GPMC\_FCLK}$  if ((CSOnTime - ClkActivationTime - 1) is a multiple of 3)  
 $F = (2 + 0.5 \times \text{CSExtraDelay}) \times \text{GPMC\_FCLK}$  if ((CSOnTime - ClkActivationTime - 2) is a multiple of 3)  
Case GpmcFCLKDivider = 3:  
 $F = 0.5 \times \text{CSExtraDelay} \times \text{GPMC\_FCLK}$  if ((CSOnTime - ClkActivationTime) is a multiple of 4)  
 $F = (1 + 0.5 \times \text{CSExtraDelay}) \times \text{GPMC\_FCLK}$  if ((CSOnTime - ClkActivationTime - 1) is a multiple of 4)  
 $F = (2 + 0.5 \times \text{CSExtraDelay}) \times \text{GPMC\_FCLK}$  if ((CSOnTime - ClkActivationTime - 2) is a multiple of 4)  
 $F = (3 + 0.5 \times \text{CSExtraDelay}) \times \text{GPMC\_FCLK}$  if ((CSOnTime - ClkActivationTime - 3) is a multiple of 4)

(8) For ADV falling edge (ADV activated):  
Case GpmcFCLKDivider = 0 :  
 $G = 0.5 \times \text{ADVExtraDelay} \times \text{GPMC\_FCLK}$   
Case GpmcFCLKDivider = 1:  
 $G = 0.5 \times \text{ADVExtraDelay} \times \text{GPMC\_FCLK}$  if (ClkActivationTime and ADVOnTime are odd) or (ClkActivationTime and ADVOnTime are even)  
 $G = (1 + 0.5 \times \text{ADVExtraDelay}) \times \text{GPMC\_FCLK}$  otherwise  
Case GpmcFCLKDivider = 2:  
 $G = 0.5 \times \text{ADVExtraDelay} \times \text{GPMC\_FCLK}$  if ((ADVOnTime - ClkActivationTime) is a multiple of 3)  
 $G = (1 + 0.5 \times \text{ADVExtraDelay}) \times \text{GPMC\_FCLK}$  if ((ADVOnTime - ClkActivationTime - 1) is a multiple of 3)

$G = (2 + 0.5 \times \text{ADVExtraDelay}) \times \text{GPMC\_FCLK}$  if  $((\text{ADVOnTime} - \text{ClkActivationTime} - 2)$  is a multiple of 3)

For ADV rising edge (ADV deactivated) in Reading mode:

Case GpmcFCLKDivider = 0:

$G = 0.5 \times \text{ADVExtraDelay} \times \text{GPMC\_FCLK}$

Case GpmcFCLKDivider = 1:

$G = 0.5 \times \text{ADVExtraDelay} \times \text{GPMC\_FCLK}$  if  $(\text{ClkActivationTime}$  and  $\text{ADVRdOffTime}$  are odd) or  $(\text{ClkActivationTime}$  and  $\text{ADVRdOffTime}$  are even)

$G = (1 + 0.5 \times \text{ADVExtraDelay}) \times \text{GPMC\_FCLK}$  otherwise

Case GpmcFCLKDivider = 2:

$G = 0.5 \times \text{ADVExtraDelay} \times \text{GPMC\_FCLK}$  if  $((\text{ADVRdOffTime} - \text{ClkActivationTime})$  is a multiple of 3)

$G = (1 + 0.5 \times \text{ADVExtraDelay}) \times \text{GPMC\_FCLK}$  if  $((\text{ADVRdOffTime} - \text{ClkActivationTime} - 1)$  is a multiple of 3)

$G = (2 + 0.5 \times \text{ADVExtraDelay}) \times \text{GPMC\_FCLK}$  if  $((\text{ADVRdOffTime} - \text{ClkActivationTime} - 2)$  is a multiple of 3)

Case GpmcFCLKDivider = 3:

$G = 0.5 \times \text{ADVExtraDelay} \times \text{GPMC\_FCLK}$  if  $((\text{ADVRdOffTime} - \text{ClkActivationTime})$  is a multiple of 4)

$G = (1 + 0.5 \times \text{ADVExtraDelay}) \times \text{GPMC\_FCLK}$  if  $((\text{ADVRdOffTime} - \text{ClkActivationTime} - 1)$  is a multiple of 4)

$G = (2 + 0.5 \times \text{ADVExtraDelay}) \times \text{GPMC\_FCLK}$  if  $((\text{ADVRdOffTime} - \text{ClkActivationTime} - 2)$  is a multiple of 4)

$G = (3 + 0.5 \times \text{ADVExtraDelay}) \times \text{GPMC\_FCLK}$  if  $((\text{ADVRdOffTime} - \text{ClkActivationTime} - 3)$  is a multiple of 4)

For ADV rising edge (ADV deactivated) in Writing mode:

Case GpmcFCLKDivider = 0:

$G = 0.5 \times \text{ADVExtraDelay} \times \text{GPMC\_FCLK}$

Case GpmcFCLKDivider = 1:

$G = 0.5 \times \text{ADVExtraDelay} \times \text{GPMC\_FCLK}$  if  $(\text{ClkActivationTime}$  and  $\text{ADVWrOffTime}$  are odd) or  $(\text{ClkActivationTime}$  and  $\text{ADVWrOffTime}$  are even)

$G = (1 + 0.5 \times \text{ADVExtraDelay}) \times \text{GPMC\_FCLK}$  otherwise

Case GpmcFCLKDivider = 2:

$G = 0.5 \times \text{ADVExtraDelay} \times \text{GPMC\_FCLK}$  if  $((\text{ADVWrOffTime} - \text{ClkActivationTime})$  is a multiple of 3)

$G = (1 + 0.5 \times \text{ADVExtraDelay}) \times \text{GPMC\_FCLK}$  if  $((\text{ADVWrOffTime} - \text{ClkActivationTime} - 1)$  is a multiple of 3)

$G = (2 + 0.5 \times \text{ADVExtraDelay}) \times \text{GPMC\_FCLK}$  if  $((\text{ADVWrOffTime} - \text{ClkActivationTime} - 2)$  is a multiple of 3)

Case GpmcFCLKDivider = 3:

$G = 0.5 \times \text{ADVExtraDelay} \times \text{GPMC\_FCLK}$  if  $((\text{ADVWrOffTime} - \text{ClkActivationTime})$  is a multiple of 4)

$G = (1 + 0.5 \times \text{ADVExtraDelay}) \times \text{GPMC\_FCLK}$  if  $((\text{ADVWrOffTime} - \text{ClkActivationTime} - 1)$  is a multiple of 4)

$G = (2 + 0.5 \times \text{ADVExtraDelay}) \times \text{GPMC\_FCLK}$  if  $((\text{ADVWrOffTime} - \text{ClkActivationTime} - 2)$  is a multiple of 4)

$G = (3 + 0.5 \times \text{ADVExtraDelay}) \times \text{GPMC\_FCLK}$  if  $((\text{ADVWrOffTime} - \text{ClkActivationTime} - 3)$  is a multiple of 4)

(9) For OE falling edge (OE activated):

Case GpmcFCLKDivider = 0:

$H = 0.5 \times \text{OEEExtraDelay} \times \text{GPMC\_FCLK}$

Case GpmcFCLKDivider = 1:

$H = 0.5 \times \text{OEEExtraDelay} \times \text{GPMC\_FCLK}$  if  $(\text{ClkActivationTime}$  and  $\text{OEOnTime}$  are odd) or  $(\text{ClkActivationTime}$  and  $\text{OEOnTime}$  are even)

$H = (1 + 0.5 \times \text{OEEExtraDelay}) \times \text{GPMC\_FCLK}$  otherwise

Case GpmcFCLKDivider = 2:

$H = 0.5 \times \text{OEEExtraDelay} \times \text{GPMC\_FCLK}$  if  $((\text{OEOnTime} - \text{ClkActivationTime})$  is a multiple of 3)

$H = (1 + 0.5 \times \text{OEEExtraDelay}) \times \text{GPMC\_FCLK}$  if  $((\text{OEOnTime} - \text{ClkActivationTime} - 1)$  is a multiple of 3)

$H = (2 + 0.5 \times \text{OEEExtraDelay}) \times \text{GPMC\_FCLK}$  if  $((\text{OEOnTime} - \text{ClkActivationTime} - 2)$  is a multiple of 3)

Case GpmcFCLKDivider = 3:

$H = 0.5 \times \text{OEEExtraDelay} \times \text{GPMC\_FCLK}$  if  $((\text{OEOnTime} - \text{ClkActivationTime})$  is a multiple of 4)

$H = (1 + 0.5 \times \text{OEEExtraDelay}) \times \text{GPMC\_FCLK}$  if  $((\text{OEOnTime} - \text{ClkActivationTime} - 1)$  is a multiple of 4)

$H = (2 + 0.5 \times \text{OEEExtraDelay}) \times \text{GPMC\_FCLK}$  if  $((\text{OEOnTime} - \text{ClkActivationTime} - 2)$  is a multiple of 4)

$H = (3 + 0.5 \times \text{OEEExtraDelay}) \times \text{GPMC\_FCLK}$  if  $((\text{OEOnTime} - \text{ClkActivationTime} - 3)$  is a multiple of 4)

For OE rising edge (OE deactivated):

Case GpmcFCLKDivider = 0:

$H = 0.5 \times \text{OEEExtraDelay} \times \text{GPMC\_FCLK}$

Case GpmcFCLKDivider = 1:

$H = 0.5 \times \text{OEEExtraDelay} \times \text{GPMC\_FCLK}$  if  $(\text{ClkActivationTime}$  and  $\text{OEOffTime}$  are odd) or  $(\text{ClkActivationTime}$  and  $\text{OEOffTime}$  are even)

$H = (1 + 0.5 \times \text{OEEExtraDelay}) \times \text{GPMC\_FCLK}$  otherwise

Case GpmcFCLKDivider = 2:

$H = 0.5 \times \text{OEEExtraDelay} \times \text{GPMC\_FCLK}$  if  $((\text{OEOffTime} - \text{ClkActivationTime})$  is a multiple of 3)

$H = (1 + 0.5 \times \text{OEEExtraDelay}) \times \text{GPMC\_FCLK}$  if  $((\text{OEOffTime} - \text{ClkActivationTime} - 1)$  is a multiple of 3)

$H = (2 + 0.5 \times \text{OEEExtraDelay}) \times \text{GPMC\_FCLK}$  if  $((\text{OEOffTime} - \text{ClkActivationTime} - 2)$  is a multiple of 3)

Case GpmcFCLKDivider = 3:

$H = 0.5 \times \text{OEEExtraDelay} \times \text{GPMC\_FCLK}$  if  $((\text{OEOffTime} - \text{ClkActivationTime})$  is a multiple of 4)

$H = (1 + 0.5 \times \text{OEEExtraDelay}) \times \text{GPMC\_FCLK}$  if  $((\text{OEOffTime} - \text{ClkActivationTime} - 1)$  is a multiple of 4)

$H = (2 + 0.5 \times \text{OEEExtraDelay}) \times \text{GPMC\_FCLK}$  if  $((\text{OEOffTime} - \text{ClkActivationTime} - 2)$  is a multiple of 4)

$H = (3 + 0.5 \times \text{OEEExtraDelay}) \times \text{GPMC\_FCLK}$  if  $((\text{OEOffTime} - \text{ClkActivationTime} - 3)$  is a multiple of 4)

(10) For WE falling edge (WE activated):

Case GpmcFCLKDivider = 0:

$I = 0.5 \times \text{WEEExtraDelay} \times \text{GPMC\_FCLK}$

Case GpmcFCLKDivider = 1:

$I = 0.5 \times \text{WEEExtraDelay} \times \text{GPMC\_FCLK}$  if  $(\text{ClkActivationTime}$  and  $\text{WEOnTime}$  are odd) or  $(\text{ClkActivationTime}$  and  $\text{WEOnTime}$  are even)

$I = (1 + 0.5 \times \text{WEEExtraDelay}) \times \text{GPMC\_FCLK}$  otherwise



Case GpmcFCLKDivider = 2:

- $l = 0.5 \times WEExtraDelay \times GPMC\_FCLK$  if  $((WEOnTime - ClkActivationTime)$  is a multiple of 3)
- $l = (1 + 0.5 \times WEExtraDelay) \times GPMC\_FCLK$  if  $((WEOnTime - ClkActivationTime - 1)$  is a multiple of 3)
- $l = (2 + 0.5 \times WEExtraDelay) \times GPMC\_FCLK$  if  $((WEOnTime - ClkActivationTime - 2)$  is a multiple of 3)

Case GpmcFCLKDivider = 3:

- $l = 0.5 \times WEExtraDelay \times GPMC\_FCLK$  if  $((WEOnTime - ClkActivationTime)$  is a multiple of 4)
- $l = (1 + 0.5 \times WEExtraDelay) \times GPMC\_FCLK$  if  $((WEOnTime - ClkActivationTime - 1)$  is a multiple of 4)
- $l = (2 + 0.5 \times WEExtraDelay) \times GPMC\_FCLK$  if  $((WEOnTime - ClkActivationTime - 2)$  is a multiple of 4)
- $l = (3 + 0.5 \times WEExtraDelay) \times GPMC\_FCLK$  if  $((WEOnTime - ClkActivationTime - 3)$  is a multiple of 4)

For WE rising edge (WE deactivated):

Case GpmcFCLKDivider = 0:

- $l = 0.5 \times WEExtraDelay \times GPMC\_FCLK$

Case GpmcFCLKDivider = 1:

- $l = 0.5 \times WEExtraDelay \times GPMC\_FCLK$  if (ClkActivationTime and WEOffTime are odd) or (ClkActivationTime and WEOffTime are even)

- $l = (1 + 0.5 \times WEExtraDelay) \times GPMC\_FCLK$  otherwise

Case GpmcFCLKDivider = 2:

- $l = 0.5 \times WEExtraDelay \times GPMC\_FCLK$  if  $((WEOffTime - ClkActivationTime)$  is a multiple of 3)
- $l = (1 + 0.5 \times WEExtraDelay) \times GPMC\_FCLK$  if  $((WEOffTime - ClkActivationTime - 1)$  is a multiple of 3)
- $l = (2 + 0.5 \times WEExtraDelay) \times GPMC\_FCLK$  if  $((WEOffTime - ClkActivationTime - 2)$  is a multiple of 3)

Case GpmcFCLKDivider = 3:

- $l = 0.5 \times WEExtraDelay \times GPMC\_FCLK$  if  $((WEOffTime - ClkActivationTime)$  is a multiple of 4)
- $l = (1 + 0.5 \times WEExtraDelay) \times GPMC\_FCLK$  if  $((WEOffTime - ClkActivationTime - 1)$  is a multiple of 4)
- $l = (2 + 0.5 \times WEExtraDelay) \times GPMC\_FCLK$  if  $((WEOffTime - ClkActivationTime - 2)$  is a multiple of 4)
- $l = (3 + 0.5 \times WEExtraDelay) \times GPMC\_FCLK$  if  $((WEOffTime - ClkActivationTime - 3)$  is a multiple of 4)

- (11)  $J = GPMC\_FCLK$  period, where GPMC\_FCLK is the General Purpose Memory Controller internal functional clock
- (12) For read:  
 $K = (ADVRdOffTime - ADVOnTime) \times (TimeParaGranularity + 1) \times GPMC\_FCLK$   
 For write:  $K = (ADVWrOffTime - ADVOnTime) \times (TimeParaGranularity + 1) \times GPMC\_FCLK$
- (13) The gpmc\_clk output clock maximum and minimum frequency is programmable in the I/F module by setting the GPMC\_CONFIG1\_CSx configuration register bit fields GpmcFCLKDivider
- (14) gpio6\_16 programmed to MUXMODE=9 (clkout1), CM\_CLKSEL\_CLKOUTMUX1 programmed to 7 (CORE\_DPLL\_OUT\_DCLK), CM\_CLKSEL\_CORE\_DPLL\_OUT\_CLK\_CLKOUTMUX programmed to 1.
- (15) CSEXTRADelay = 0, ADVEXTRADelay = 0, WEEXTRADelay = 0, OEEXTRADelay = 0. Extra half-GPMC\_FCLK cycle delay mode is not timed.

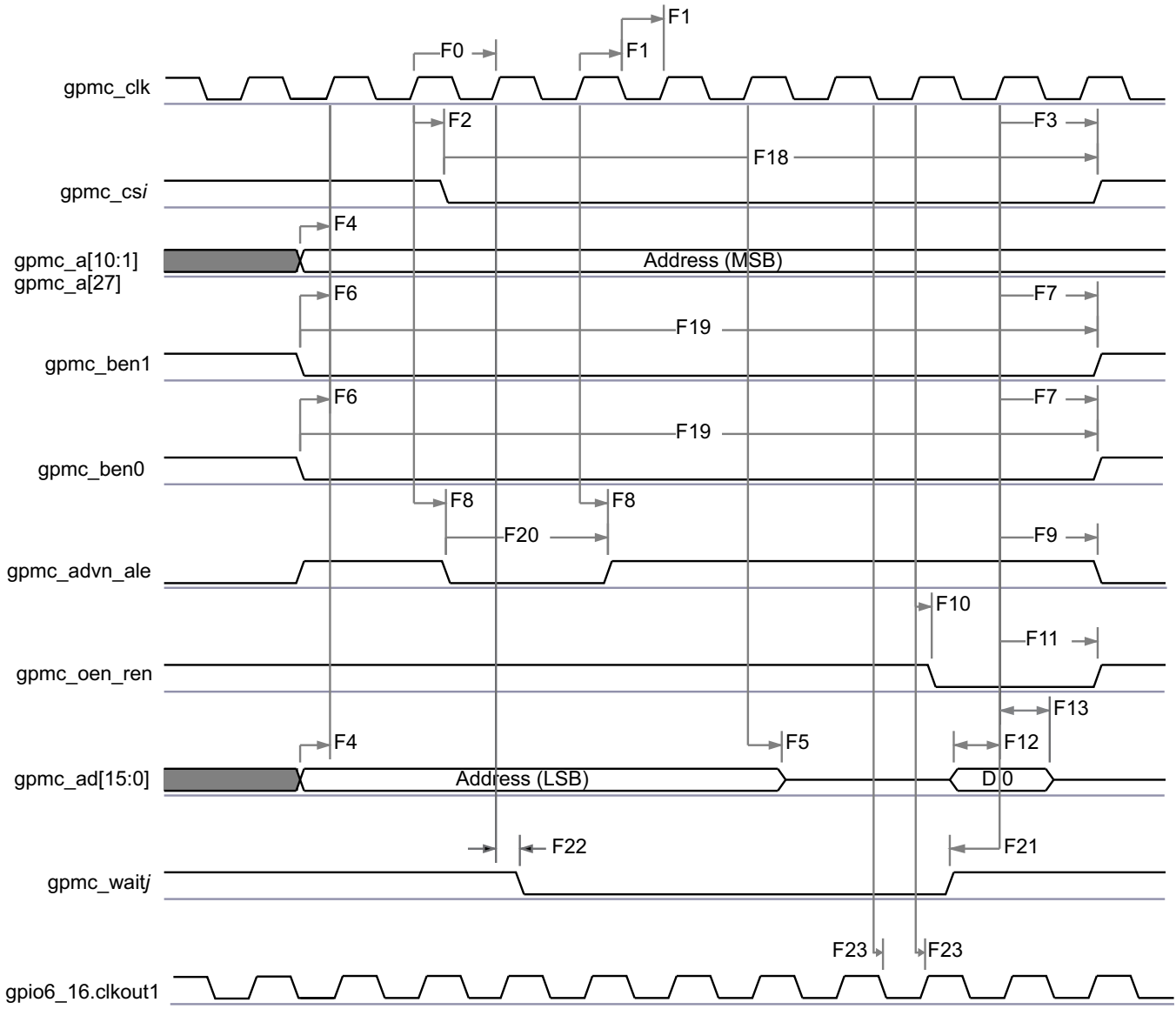

GPMC\_01

**Figure 5-23. GPMC / Multiplexed 16bits NOR Flash - Synchronous Single Read - (GpmcFCLKDivider = 0)<sup>(1)(2)</sup>**

(1) In gpmc\_csi, i = 0 to 7.

(2) In gpmc\_waitj, j = 0 to 1.

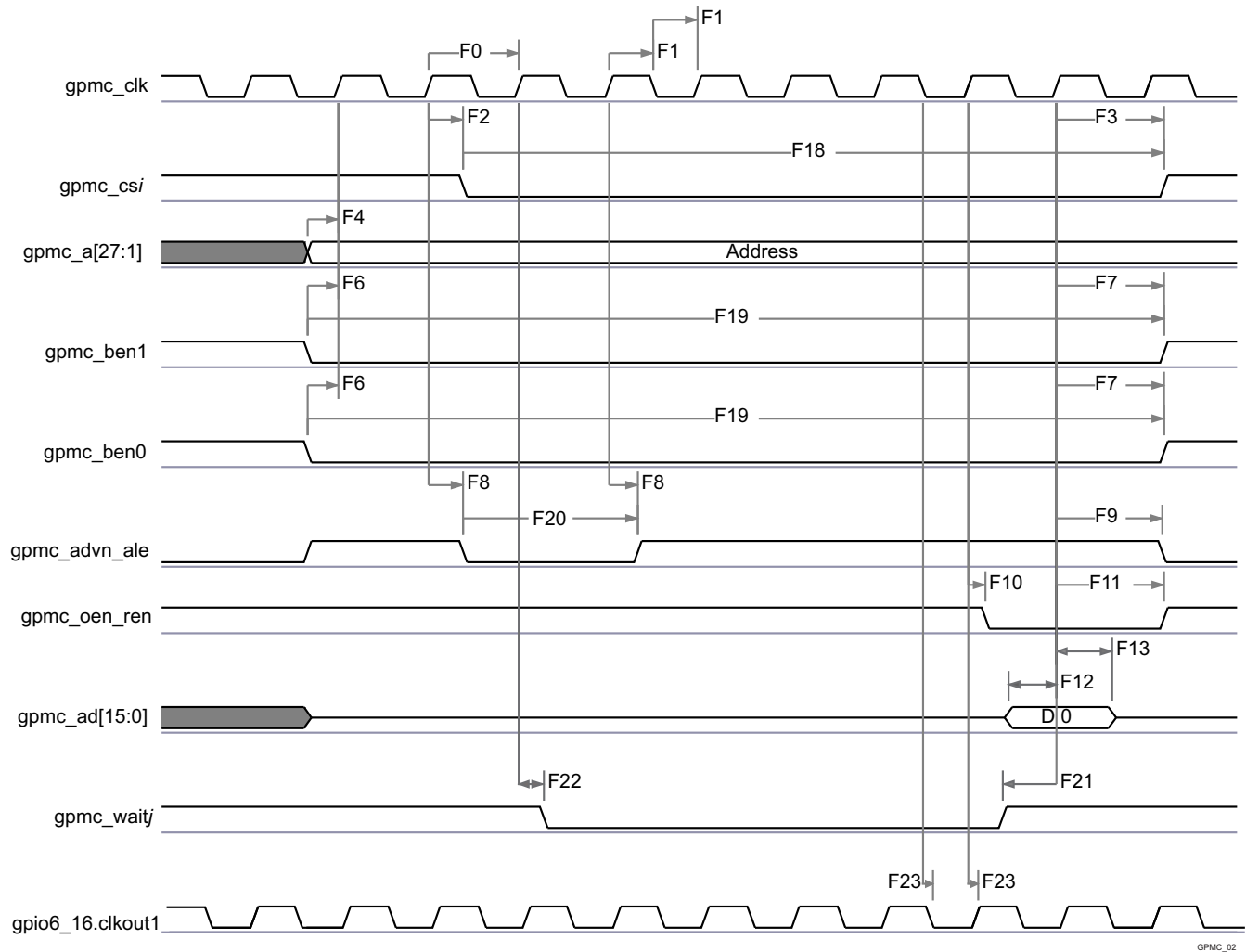
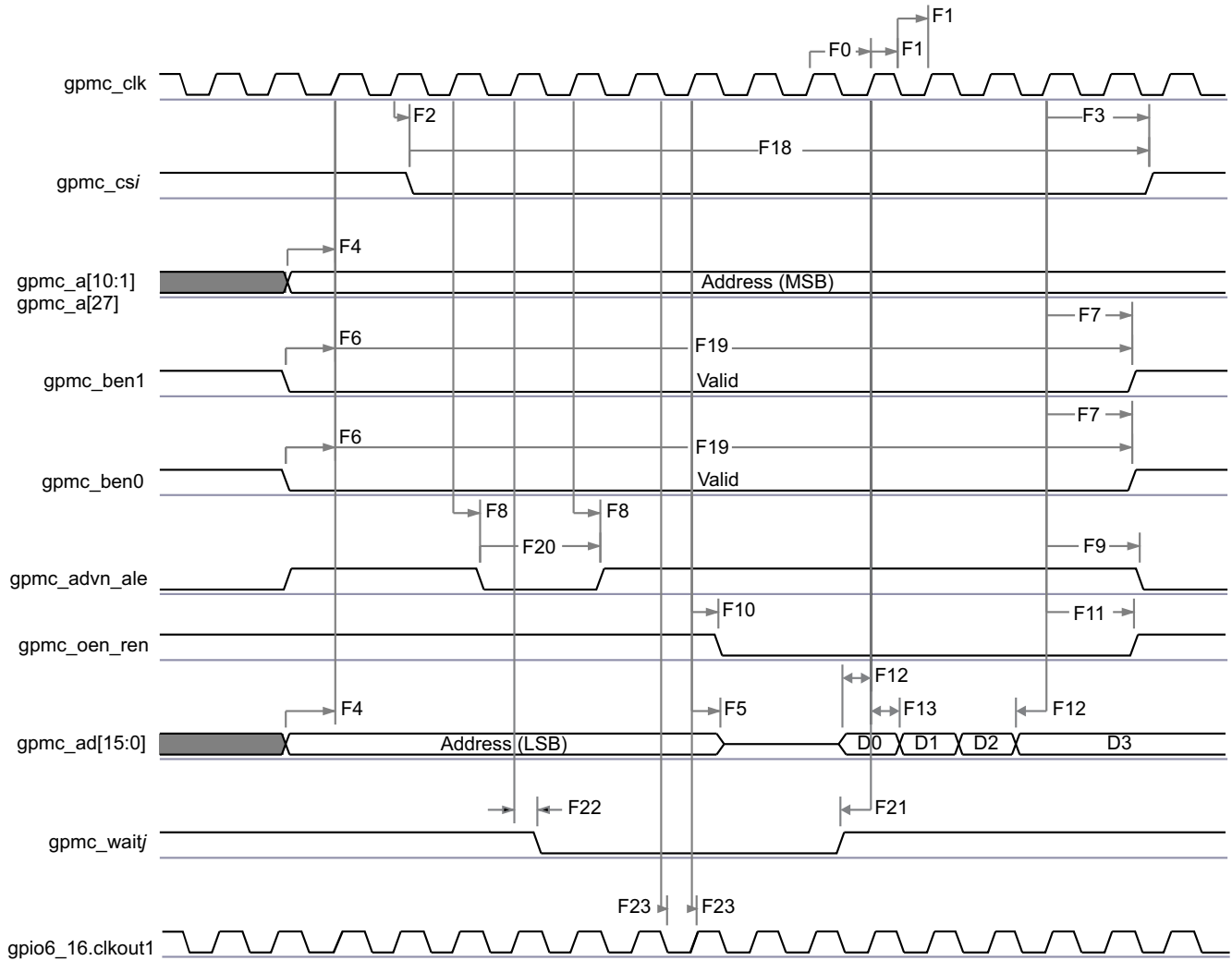

Figure 5-24. GPMC / Nonmultiplexed 16bits NOR Flash - Synchronous Single Read - (GpmcFCLKDivider = 0)<sup>(1)(2)</sup>

- (1) In gpmc\_csi, i = 0 to 7.
- (2) In gpmc\_waitj, j = 0 to 1.



GPMC\_03

**Figure 5-25. GPMC / Multiplexed 16bits NOR Flash - Synchronous Burst Read 4x16 bits - (GpmcFCLKDivider = 0)<sup>(1)(2)</sup>**

- (1) In gpmc\_csi, i= 0 to 7.
- (2) In gpmc\_waitj, j = 0 to 1.

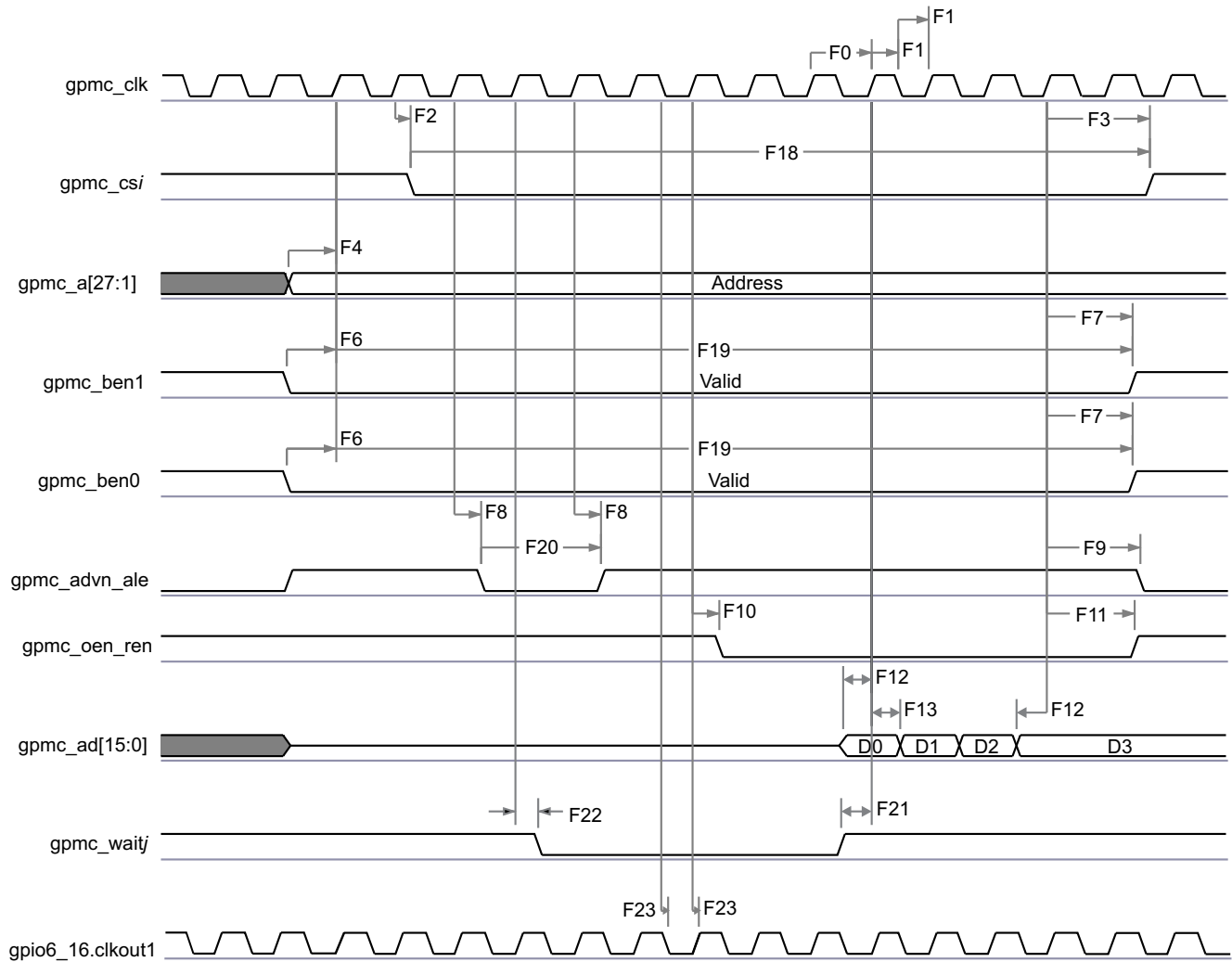

GPMC\_04

**Figure 5-26. GPMC / Nonmultiplexed 16bits NOR Flash - Synchronous Burst Read 4x16 bits - (GpmcFCLKDivider = 0)<sup>(1)(2)</sup>**

- (1) In gpmc\_csi, i = 0 to 7.
- (2) In gpmc\_waitj, j = 0 to 1.

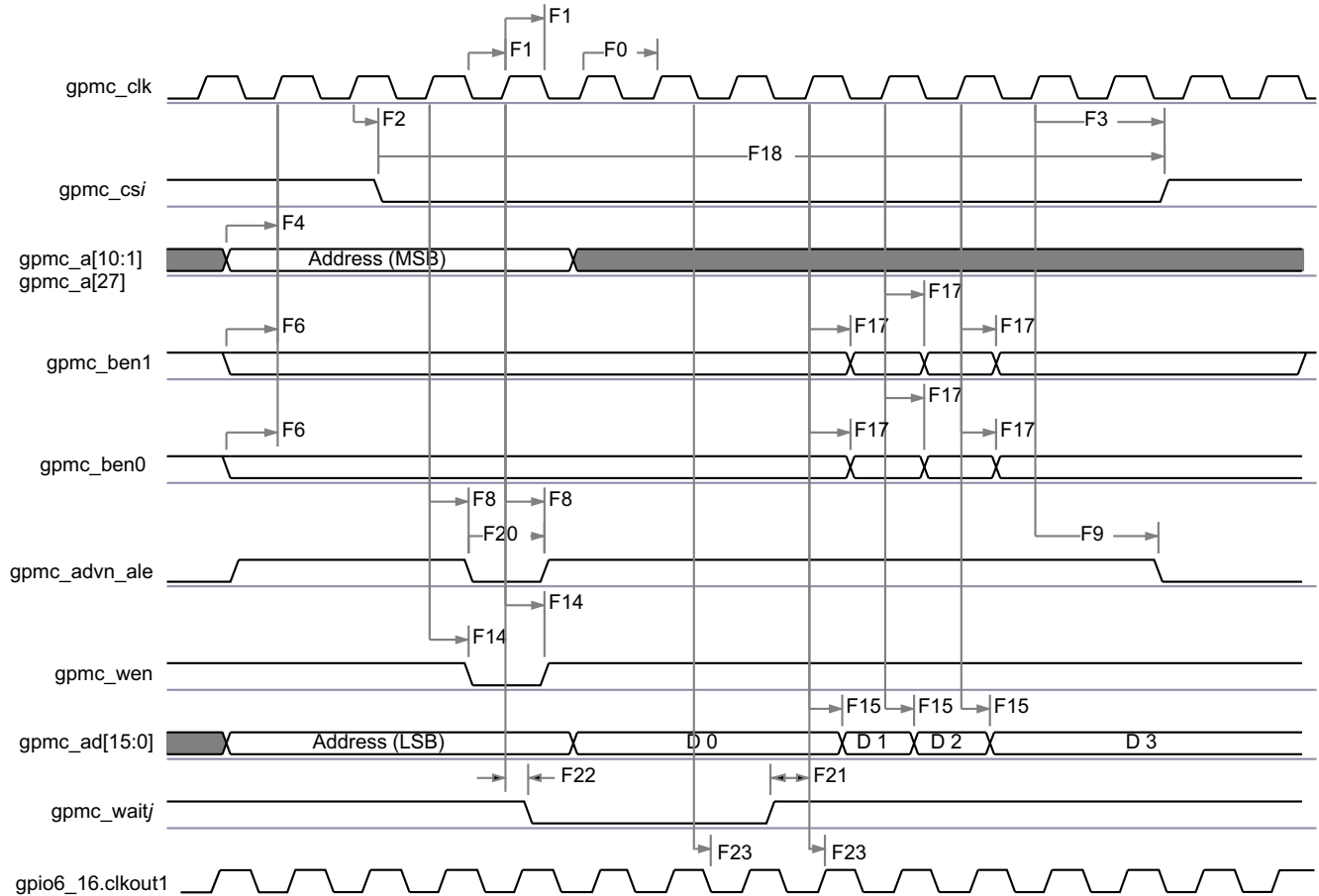

GPMC\_05

**Figure 5-27. GPMC / Multiplexed 16bits NOR Flash - Synchronous Burst Write 4x16bits - (GpmcFCLKDivider = 0)<sup>(1)(2)</sup>**

- (1) In “gpmc\_csi”, i = 0 to 7.
- (2) In “gpmc\_waitj”, j = 0 to 1.

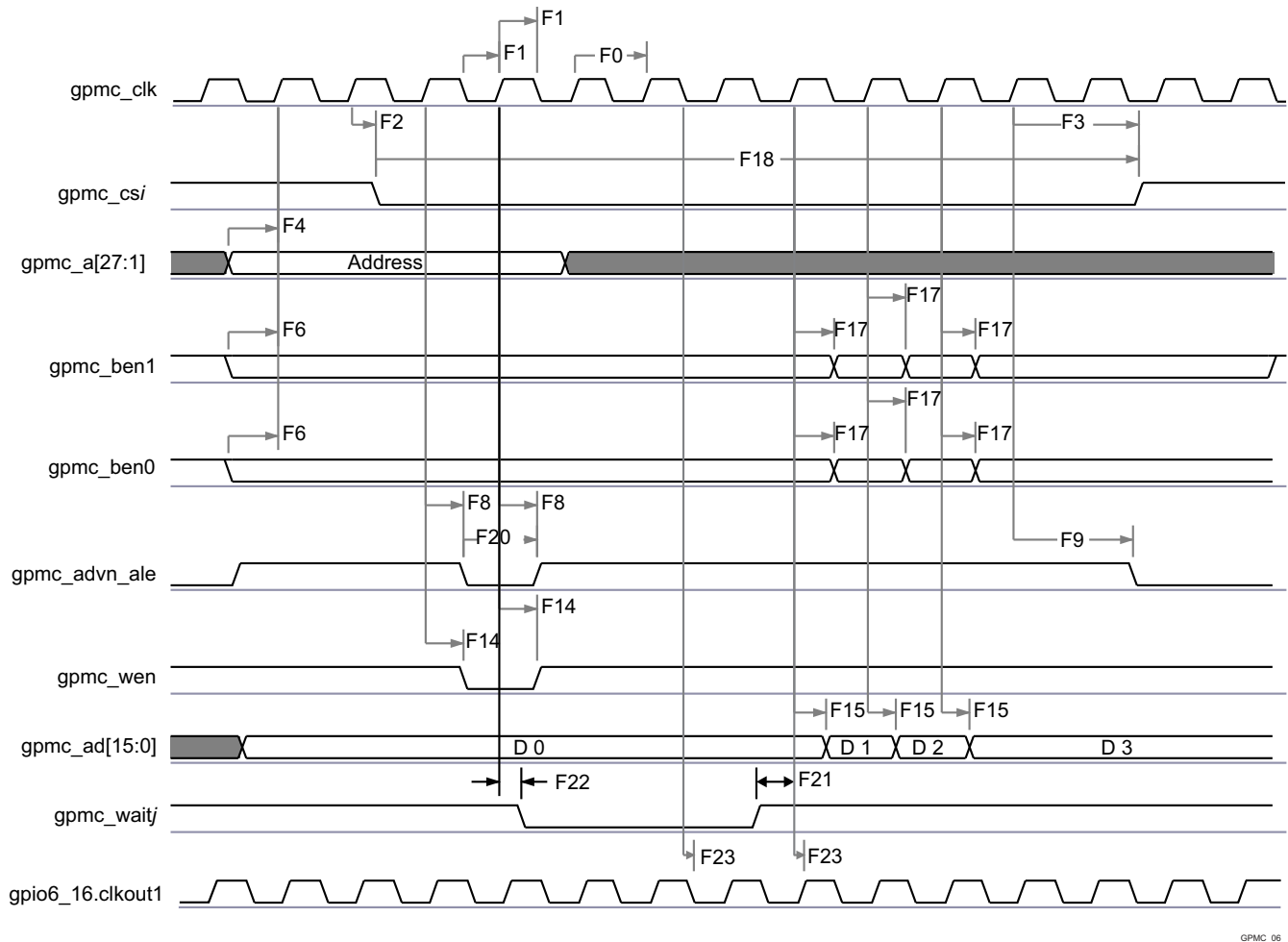

**Figure 5-28. GPMC / Nonmultiplexed 16bits NOR Flash - Synchronous Burst Write 4x16bits - (GpmcFCLKDivider = 0)<sup>(1)(2)</sup>**

- (1) In “gpmc\_csi”, i = 1 to 7.
- (2) In “gpmc\_waitj”, j = 0 to 1.

**5.10.6.8.2 GPMC/NOR Flash Interface Asynchronous Timing**

**CAUTION**

The I/O Timings provided in this section are valid only for some GPMC usage modes when the corresponding Virtual I/O Timings or Manual I/O Timings are configured as described in the tables found in this section.

Table 5-50 and Table 5-51 assume testing over the recommended operating conditions and electrical characteristic conditions below (see Figure 5-29, Figure 5-30, Figure 5-31, Figure 5-32, Figure 5-33 and Figure 5-34).

**Table 5-50. GPMC/NOR Flash Interface Timing Requirements - Asynchronous Mode**

NO.	PARAMETER	DESCRIPTION	MIN	MAX	UNIT
FA5	t <sub>acc(DAT)</sub>	Data Maximum Access Time (GPMC_FCLK cycles)		H <sup>(1)</sup>	cycles

**Table 5-50. GPMC/NOR Flash Interface Timing Requirements - Asynchronous Mode (continued)**

NO.	PARAMETER	DESCRIPTION	MIN	MAX	UNIT
FA20	$t_{acc1-pgmode}(DAT)$	Page Mode Successive Data Maximum Access Time (GPMC_FCLK cycles)		P <sup>(2)</sup>	cycles
FA21	$t_{acc2-pgmode}(DAT)$	Page Mode First Data Maximum Access Time (GPMC_FCLK cycles)		H <sup>(1)</sup>	cycles
-	$t_{su}(DV-OEH)$	Setup time, read gpmc_ad[15:0] valid before gpmc_oen_ren high	1.9		ns
-	$t_h(OEH-DV)$	Hold time, read gpmc_ad[15:0] valid after gpmc_oen_ren high	1		ns

(1) H = Access Time × (TimeParaGranularity + 1)

(2) P = PageBurstAccessTime × (TimeParaGranularity + 1)

**Table 5-51. GPMC/NOR Flash Interface Switching Characteristics - Asynchronous Mode**

NO.	PARAMETER	DESCRIPTION	MIN	MAX	UNIT
-	$t_r(DO)$	Rising time, gpmc_ad[15:0] output data	0.447	4.067	ns
-	$t_f(DO)$	Falling time, gpmc_ad[15:0] output data	0.43	4.463	ns
FA0	$t_w(nBEV)$	Pulse duration, gpmc_ben[1:0] valid time		N <sup>(1)</sup>	ns
FA1	$t_w(nCSV)$	Pulse duration, gpmc_cs[7:0] low		A <sup>(2)</sup>	ns
FA3	$t_d(nCSV-nADVIV)$	Delay time, gpmc_cs[7:0] valid to gpmc_advn_ale invalid	B - 2 <sup>(3)</sup>	B + 4 <sup>(3)</sup>	ns
FA4	$t_d(nCSV-nOEIV)$	Delay time, gpmc_cs[7:0] valid to gpmc_oen_ren invalid (Single read)	C - 2 <sup>(4)</sup>	C + 4 <sup>(4)</sup>	ns
FA9	$t_d(AV-nCSV)$	Delay time, address bus valid to gpmc_cs[7:0] valid	J - 2 <sup>(5)</sup>	J + 4 <sup>(5)</sup>	ns
FA10	$t_d(nBEV-nCSV)$	Delay time, gpmc_ben[1:0] valid to gpmc_cs[7:0] valid	J - 2 <sup>(5)</sup>	J + 4 <sup>(5)</sup>	ns
FA12	$t_d(nCSV-nADVIV)$	Delay time, gpmc_cs[7:0] valid to gpmc_advn_ale valid	K - 2 <sup>(6)</sup>	K + 4 <sup>(6)</sup>	ns
FA13	$t_d(nCSV-nOEIV)$	Delay time, gpmc_cs[7:0] valid to gpmc_oen_ren valid	L - 2 <sup>(7)</sup>	L + 4 <sup>(7)</sup>	ns
FA16	$t_w(AIV)$	Pulse duration, address invalid between 2 successive R/W accesses	G <sup>(8)</sup>		ns
FA18	$t_d(nCSV-nOEIV)$	Delay time, gpmc_cs[7:0] valid to gpmc_oen_ren invalid (Burst read)	I - 2 <sup>(9)</sup>	I + 4 <sup>(9)</sup>	ns
FA20	$t_w(AV)$	Pulse duration, address valid : 2nd, 3rd and 4th accesses	D <sup>(10)</sup>		ns
FA25	$t_d(nCSV-nWEV)$	Delay time, gpmc_cs[7:0] valid to gpmc_wen valid	E - 2 <sup>(11)</sup>	E + 4 <sup>(11)</sup>	ns
FA27	$t_d(nCSV-nWEIV)$	Delay time, gpmc_cs[7:0] valid to gpmc_wen invalid	F - 2 <sup>(12)</sup>	F + 4 <sup>(12)</sup>	ns
FA28	$t_d(nWEV-DV)$	Delay time, gpmc_wen valid to data bus valid		2	ns
FA29	$t_d(DV-nCSV)$	Delay time, data bus valid to gpmc_cs[7:0] valid	J - 2 <sup>(5)</sup>	J + 4 <sup>(5)</sup>	ns
FA37	$t_d(nOEIV-AIV)$	Delay time, gpmc_oen_ren valid to gpmc_ad[15:0] multiplexed address bus phase end		2	ns

(1) For single read: N = RdCycleTime × (TimeParaGranularity + 1) × GPMC\_FCLK

For single write: N = WrCycleTime × (TimeParaGranularity + 1) × GPMC\_FCLK

For burst read: N = (RdCycleTime + (n - 1) × PageBurstAccessTime) × (TimeParaGranularity + 1) × GPMC\_FCLK

For burst write: N = (WrCycleTime + (n - 1) × PageBurstAccessTime) × (TimeParaGranularity + 1) × GPMC\_FCLK

(2) For single read: A = (CSRdOffTime - CSOnTime) × (TimeParaGranularity + 1) × GPMC\_FCLK

For single write: A = (CSWrOffTime - CSOnTime) × (TimeParaGranularity + 1) × GPMC\_FCLK

For burst read: A = (CSRdOffTime - CSOnTime + (n - 1) × PageBurstAccessTime) × (TimeParaGranularity + 1) × GPMC\_FCLK

For burst write: A = (CSWrOffTime - CSOnTime + (n - 1) × PageBurstAccessTime) × (TimeParaGranularity + 1) × GPMC\_FCLK

(3) For reading: B = ((ADVrOffTime - CSOnTime) × (TimeParaGranularity + 1) + 0.5 × (ADVExtraDelay - CSEExtraDelay)) × GPMC\_FCLK

For writing: B = ((ADVWrOffTime - CSOnTime) × (TimeParaGranularity + 1) + 0.5 × (ADVExtraDelay - CSEExtraDelay)) × GPMC\_FCLK

(4) C = ((OEOffTime - CSOnTime) × (TimeParaGranularity + 1) + 0.5 × (OEEExtraDelay - CSEExtraDelay)) × GPMC\_FCLK

(5) J = (CSOnTime × (TimeParaGranularity + 1) + 0.5 × CSEExtraDelay) × GPMC\_FCLK

(6) K = ((ADVOnTime - CSOnTime) × (TimeParaGranularity + 1) + 0.5 × (ADVExtraDelay - CSEExtraDelay)) × GPMC\_FCLK

(7) L = ((OEOnTime - CSOnTime) × (TimeParaGranularity + 1) + 0.5 × (OEEExtraDelay - CSEExtraDelay)) × GPMC\_FCLK

(8) G = Cycle2CycleDelay × GPMC\_FCLK × (TimeParaGranularity + 1)

(9) I = ((OEOffTime + (n - 1) × PageBurstAccessTime - CSOnTime) × (TimeParaGranularity + 1) + 0.5 × (OEEExtraDelay - CSEExtraDelay)) × GPMC\_FCLK

(10) D = PageBurstAccessTime × (TimeParaGranularity + 1) × GPMC\_FCLK

(11) E = ((WEOnTime - CSOnTime) × (TimeParaGranularity + 1) + 0.5 × (WEEExtraDelay - CSEExtraDelay)) × GPMC\_FCLK

(12) F = ((WEOffTime - CSOnTime) × (TimeParaGranularity + 1) + 0.5 × (WEEExtraDelay - CSEExtraDelay)) × GPMC\_FCLK



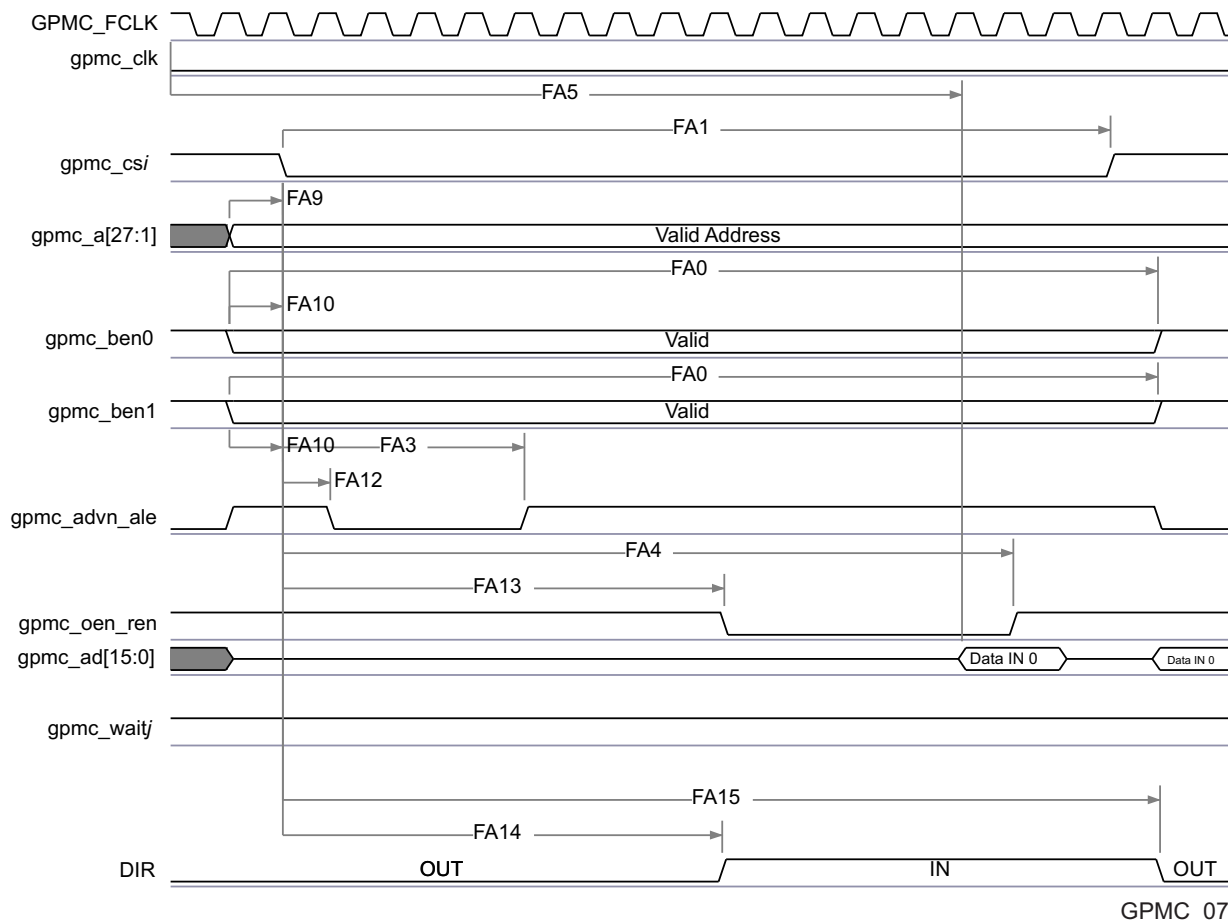

**Figure 5-29. GPMC / NOR Flash - Asynchronous Read - Single Word Timing<sup>(1)(2)(3)</sup>**

- (1) In  $gpmc\_csi$ ,  $i = 0$  to 7. In  $gpmc\_waitj$ ,  $j = 0$  to 1.
- (2) FA5 parameter illustrates amount of time required to internally sample input data. It is expressed in number of GPMC functional clock cycles. From start of read cycle and after FA5 functional clock cycles, input Data will be internally sampled by active functional clock edge. FA5 value must be stored inside AccessTime register bits field.
- (3) GPMC\_FCLK is an internal clock (GPMC functional clock) not provided externally.
- (4) The "DIR" (direction control) output signal is NOT pinned out on any of the device pads. It is an internal signal only representing a signal direction on the GPMC data bus.

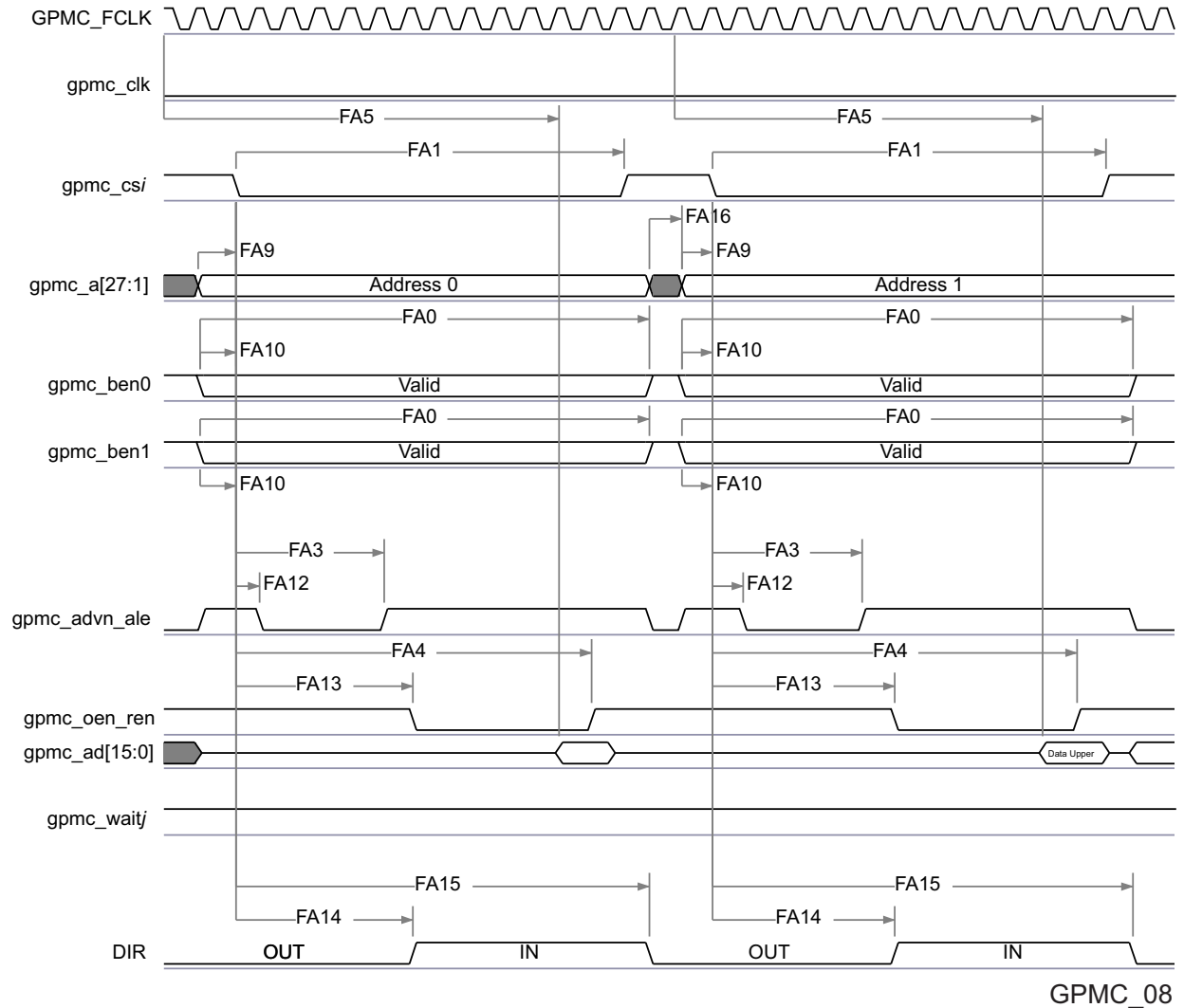

**Figure 5-30. GPMC / NOR Flash - Asynchronous Read - 32-bit Timing<sup>(1)(2)(3)</sup>**

- (1) In "gpmc\_csi",  $i = 0$  to 7. In "gpmc\_waitj",  $j = 0$  to 1.
- (2) FA5 parameter illustrates amount of time required to internally sample input Data. It is expressed in number of GPMC functional clock cycles. From start of read cycle and after FA5 functional clock cycles, input Data will be internally sampled by active functional clock edge. FA5 value should be stored inside AccessTime register bits field
- (3) GPMC\_FCLK is an internal clock (GPMC functional clock) not provided externally
- (4) The "DIR" (direction control) output signal is NOT pinned out on any of the device pads. It is an internal signal only representing a signal direction on the GPMC data bus.

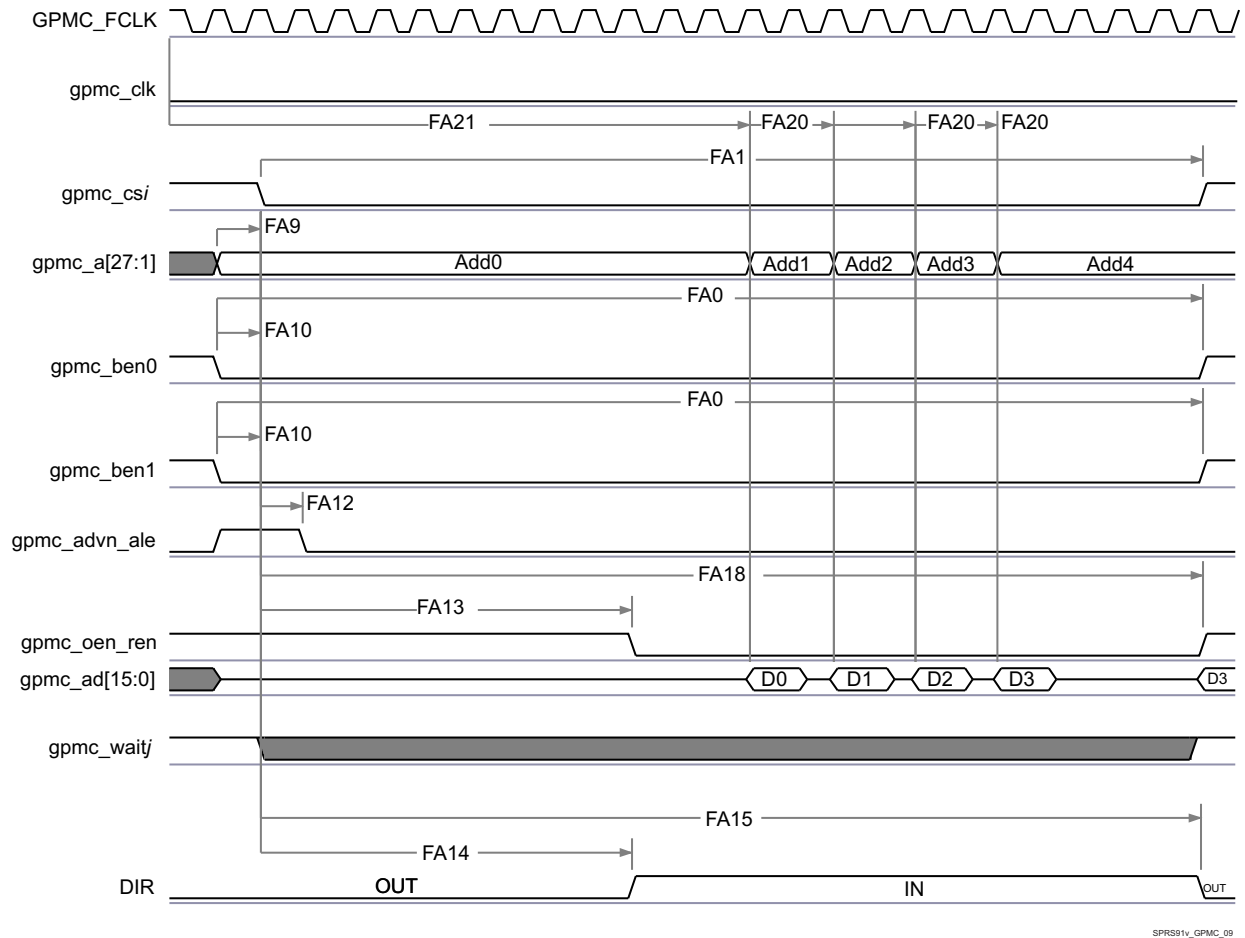

**Figure 5-31. GPMC / NOR Flash - Asynchronous Read - Page Mode 4x16-bit Timing<sup>(1)(2)(3)(4)</sup>**

- (1) In "gpmc\_csi", i = 0 to 7. In "gpmc\_waitj", j = 0 to 1
- (2) FA21 parameter illustrates amount of time required to internally sample first input Page Data. It is expressed in number of GPMC functional clock cycles. From start of read cycle and after FA21 functional clock cycles, First input Page Data will be internally sampled by active functional clock edge. FA21 calculation is detailed in a separated application note and should be stored inside AccessTime register bits field.
- (3) FA20 parameter illustrates amount of time required to internally sample successive input Page Data. It is expressed in number of GPMC functional clock cycles. After each access to input Page Data, next input Page Data will be internally sampled by active functional clock edge after FA20 functional clock cycles. FA20 is also the duration of address phases for successive input Page Data (excluding first input Page Data). FA20 value should be stored in PageBurstAccessTime register bits field.
- (4) GPMC\_FCLK is an internal clock (GPMC functional clock) not provided externally
- (5) The "DIR" (direction control) output signal is NOT pinned out on any of the device pads. It is an internal signal only representing a signal direction on the GPMC data bus.

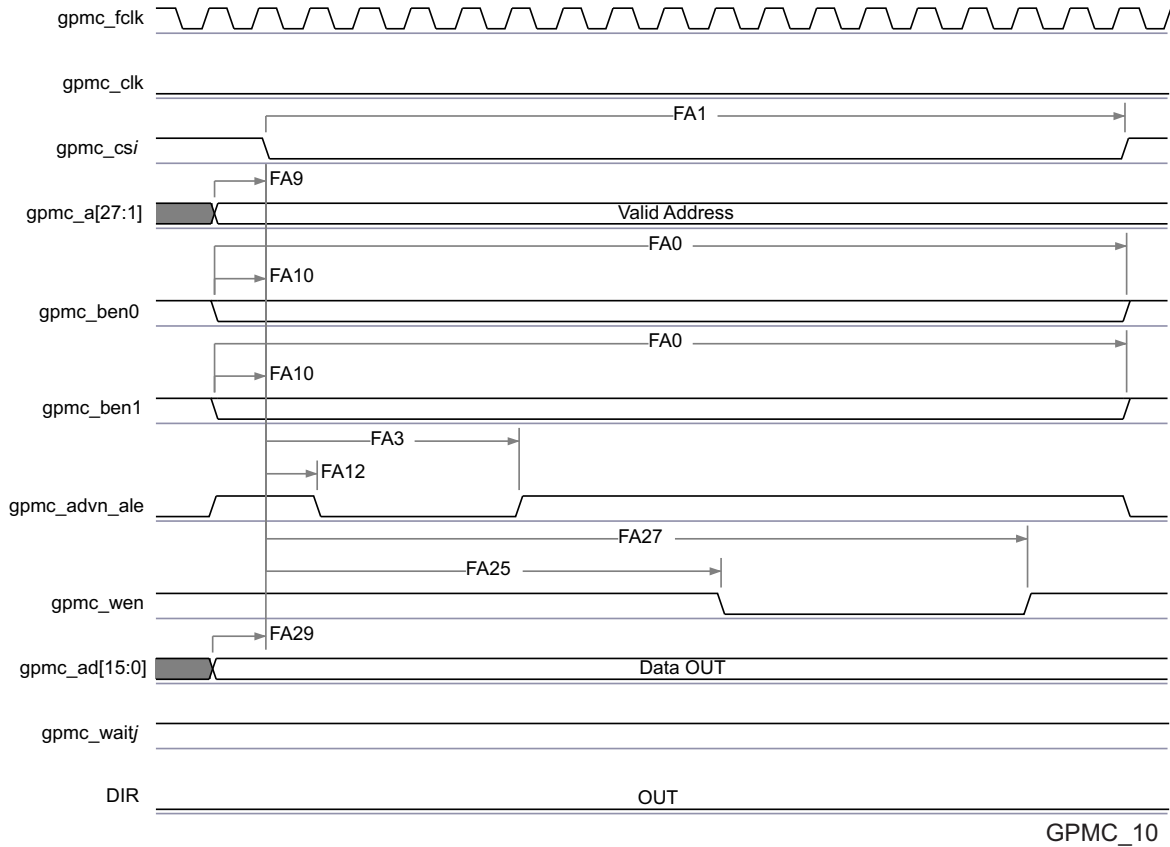

**Figure 5-32. GPMC / NOR Flash - Asynchronous Write - Single Word Timing<sup>(1)</sup>**

- (1) In "gpmc\_csi", i = 0 to 7. In "gpmc\_waitj", j = 0 to 1.
- (2) The "DIR" (direction control) output signal is NOT pinned out on any of the device pads. It is an internal signal only representing a signal direction on the GPMC data bus.

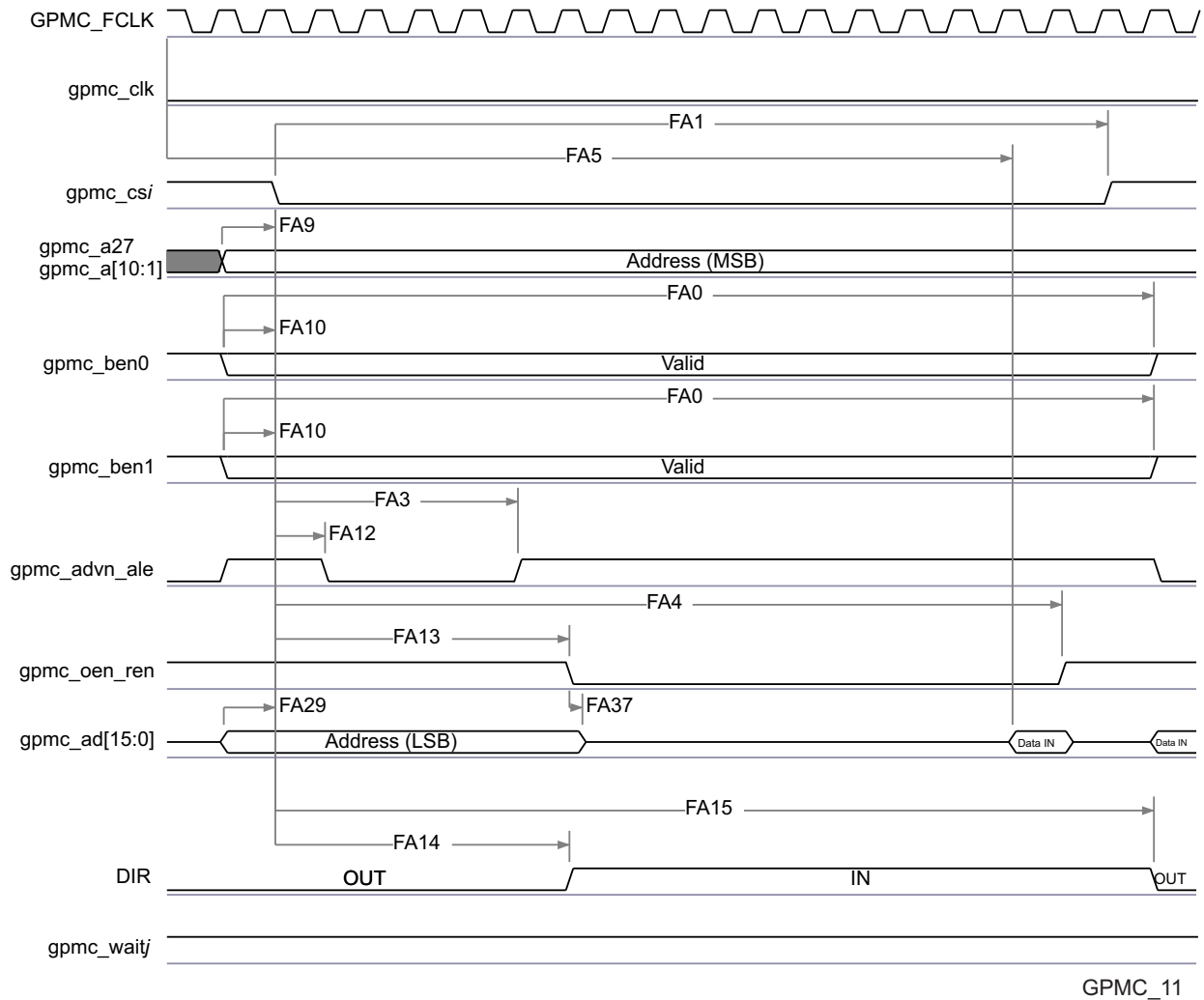

GPMC\_11

**Figure 5-33. GPMC / Multiplexed NOR Flash - Asynchronous Read - Single Word Timing<sup>(1)(2)(3)</sup>**

- (1) In "gpmc\_csi", i = 0 to 7. In "gpmc\_waitj", j = 0 to 1
- (2) FA5 parameter illustrates amount of time required to internally sample input Data. It is expressed in number of GPMC functional clock cycles. From start of read cycle and after FA5 functional clock cycles, input Data will be internally sampled by active functional clock edge. FA5 value should be stored inside AccessTime register bits field.
- (3) GPMC\_FCLK is an internal clock (GPMC functional clock) not provided externally
- (4) The "DIR" (direction control) output signal is NOT pinned out on any of the device pads. It is an internal signal only representing a signal direction on the GPMC data bus.

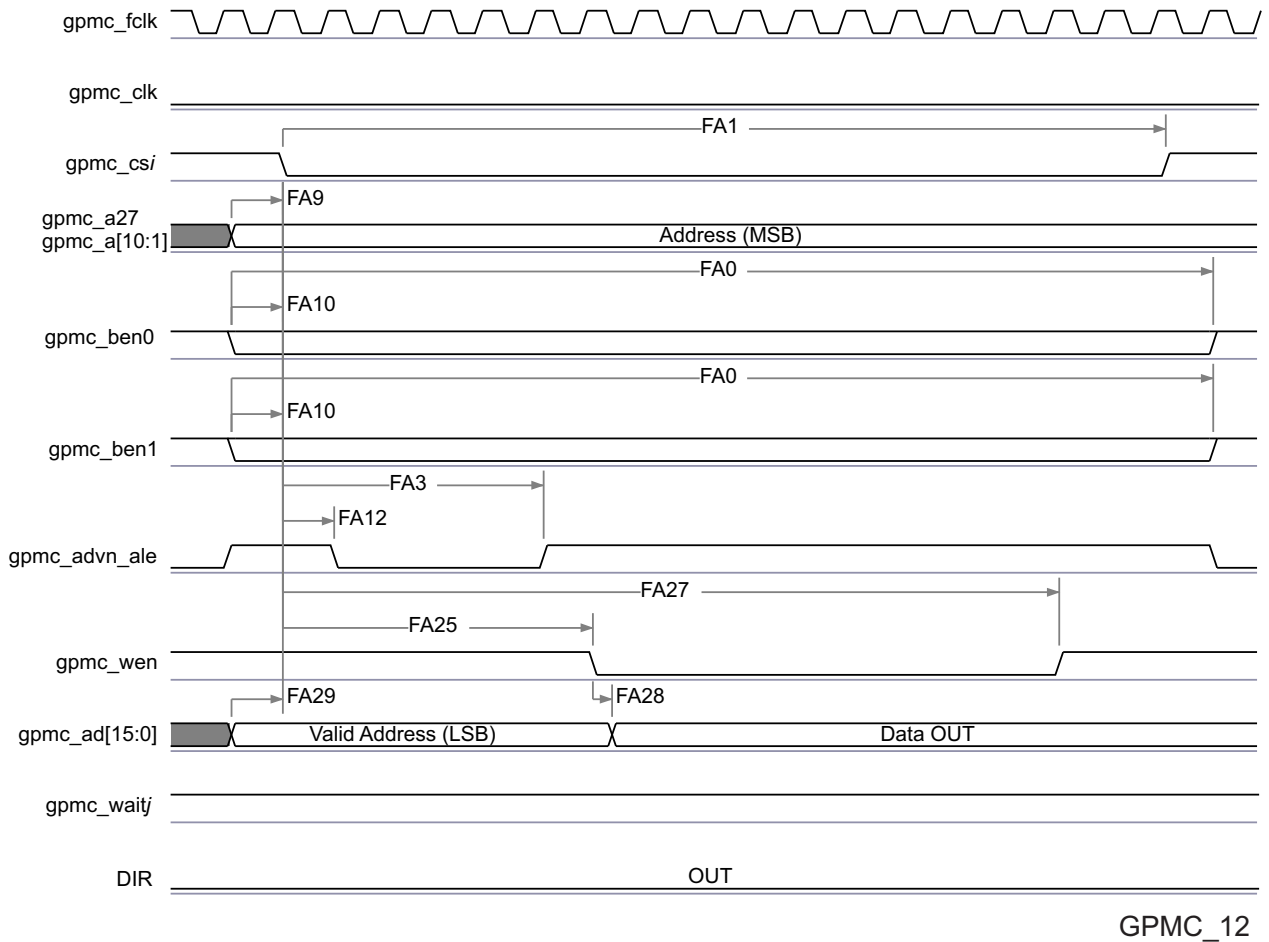

**Figure 5-34. GPMC / Multiplexed NOR Flash - Asynchronous Write - Single Word Timing<sup>(1)</sup>**

- (1) In "gpmc\_csi", i = 0 to 7. In "gpmc\_waitj", j = 0 to 1.
- (2) The "DIR" (direction control) output signal is NOT pinned out on any of the device pads. It is an internal signal only representing a signal direction on the GPMC data bus.

**5.10.6.8.3 GPMC/NAND Flash Interface Asynchronous Timing**

**CAUTION**

The I/O Timings provided in this section are valid only for some GPMC usage modes when the corresponding Virtual I/O Timings or Manual I/O Timings are configured as described in the tables found in this section.

Table 5-52 and Table 5-53 assume testing over the recommended operating conditions and electrical characteristic conditions below (see Figure 5-35, Figure 5-36, Figure 5-37 and Figure 5-38).

**Table 5-52. GPMC/NAND Flash Interface Timing Requirements**

NO.	PARAMETER	DESCRIPTION	MIN	MAX	UNIT
GNF12	t <sub>acc</sub> (DAT)	Data maximum access time (GPMC_FCLK Cycles)		J <sup>(1)</sup>	cycles
-	t <sub>su</sub> (DV-OEH)	Setup time, read gpmc_ad[15:0] valid before gpmc_oen_ren high	1.9		ns
-	t <sub>h</sub> (OEH-DV)	Hold time, read gpmc_ad[15:0] valid after gpmc_oen_ren high	1		ns

$$(1) J = \text{AccessTime} \times (\text{TimeParaGranularity} + 1)$$

**Table 5-53. GPMC/NAND Flash Interface Switching Characteristics**

NO.	PARAMETER	DESCRIPTION	MIN	MAX	UNIT
-	$t_{r(\text{DO})}$	Rising time, gpmc_ad[15:0] output data	0.447	4.067	ns
-	$t_{f(\text{DO})}$	Falling time, gpmc_ad[15:0] output data	0.43	4.463	ns
GNF0	$t_{w(\text{nWEV})}$	Pulse duration, gpmc_wen valid time		A <sup>(1)</sup>	ns
GNF1	$t_{d(\text{nCSV-nWEV})}$	Delay time, gpmc_cs[7:0] valid to gpmc_wen valid	B - 2 <sup>(2)</sup>	B + 4 <sup>(2)</sup>	ns
GNF2	$t_{d(\text{CLEH-nWEV})}$	Delay time, gpmc_ben[1:0] high to gpmc_wen valid	C - 2 <sup>(3)</sup>	C + 4 <sup>(3)</sup>	ns
GNF3	$t_{d(\text{nWEV-DV})}$	Delay time, gpmc_ad[15:0] valid to gpmc_wen valid	D - 2 <sup>(4)</sup>	D + 4 <sup>(4)</sup>	ns
GNF4	$t_{d(\text{nWEIV-DIV})}$	Delay time, gpmc_wen invalid to gpmc_ad[15:0] invalid	E - 2 <sup>(5)</sup>	E + 4 <sup>(5)</sup>	ns
GNF5	$t_{d(\text{nWEIV-CLEIV})}$	Delay time, gpmc_wen invalid to gpmc_ben[1:0] invalid	F - 2 <sup>(6)</sup>	F + 4 <sup>(6)</sup>	ns
GNF6	$t_{d(\text{nWEIV-nCSV})}$	Delay time, gpmc_wen invalid to gpmc_cs[7:0] invalid	G - 2 <sup>(7)</sup>	G + 4 <sup>(7)</sup>	ns
GNF7	$t_{d(\text{ALEH-nWEV})}$	Delay time, gpmc_advn_ale high to gpmc_wen valid	C - 2 <sup>(3)</sup>	C + 4 <sup>(3)</sup>	ns
GNF8	$t_{d(\text{nWEIV-ALEIV})}$	Delay time, gpmc_wen invalid to gpmc_advn_ale invalid	F - 2 <sup>(6)</sup>	F + 4 <sup>(6)</sup>	ns
GNF9	$t_{c(\text{nWE})}$	Cycle time, write cycle time		H <sup>(8)</sup>	ns
GNF10	$t_{d(\text{nCSV-nOEIV})}$	Delay time, gpmc_cs[7:0] valid to gpmc_oen_ren valid	I - 2 <sup>(9)</sup>	I + 4 <sup>(9)</sup>	ns
GNF13	$t_{w(\text{nOEIV})}$	Pulse duration, gpmc_oen_ren valid time		K <sup>(10)</sup>	ns
GNF14	$t_{c(\text{nOE})}$	Cycle time, read cycle time		L <sup>(11)</sup>	ns
GNF15	$t_{d(\text{nOEIV-nCSV})}$	Delay time, gpmc_oen_ren invalid to gpmc_cs[7:0] invalid	M - 2 <sup>(12)</sup>	M + 4 <sup>(12)</sup>	ns

$$(1) A = (\text{WEOffTime} - \text{WEOntime}) \times (\text{TimeParaGranularity} + 1) \times \text{GPMC\_FCLK}$$

$$(2) B = ((\text{WEOntime} - \text{CSOnTime}) \times (\text{TimeParaGranularity} + 1) + 0.5 \times (\text{WEEExtraDelay} - \text{CSEExtraDelay})) \times \text{GPMC\_FCLK}$$

$$(3) C = ((\text{WEOntime} - \text{ADVOnTime}) \times (\text{TimeParaGranularity} + 1) + 0.5 \times (\text{WEEExtraDelay} - \text{ADVEExtraDelay})) \times \text{GPMC\_FCLK}$$

$$(4) D = (\text{WEOntime} \times (\text{TimeParaGranularity} + 1) + 0.5 \times \text{WEEExtraDelay}) \times \text{GPMC\_FCLK}$$

$$(5) E = (\text{WrCycleTime} - \text{WEOffTime} \times (\text{TimeParaGranularity} + 1) - 0.5 \times \text{WEEExtraDelay}) \times \text{GPMC\_FCLK}$$

$$(6) F = (\text{ADVWrOffTime} - \text{WEOffTime} \times (\text{TimeParaGranularity} + 1) + 0.5 \times (\text{ADVEExtraDelay} - \text{WEEExtraDelay})) \times \text{GPMC\_FCLK}$$

$$(7) G = (\text{CSWrOffTime} - \text{WEOffTime} \times (\text{TimeParaGranularity} + 1) + 0.5 \times (\text{CSEExtraDelay} - \text{WEEExtraDelay})) \times \text{GPMC\_FCLK}$$

$$(8) H = \text{WrCycleTime} \times (1 + \text{TimeParaGranularity}) \times \text{GPMC\_FCLK}$$

$$(9) I = ((\text{OEOffTime} + (n - 1) \times \text{PageBurstAccessTime} - \text{CSOnTime}) \times (\text{TimeParaGranularity} + 1) + 0.5 \times (\text{OEEExtraDelay} - \text{CSEExtraDelay})) \times \text{GPMC\_FCLK}$$

$$(10) K = (\text{OEOffTime} - \text{OEOnTime}) \times (1 + \text{TimeParaGranularity}) \times \text{GPMC\_FCLK}$$

$$(11) L = \text{RdCycleTime} \times (1 + \text{TimeParaGranularity}) \times \text{GPMC\_FCLK}$$

$$(12) M = (\text{CSRdOffTime} - \text{OEOffTime} \times (\text{TimeParaGranularity} + 1) + 0.5 \times (\text{CSEExtraDelay} - \text{OEEExtraDelay})) \times \text{GPMC\_FCLK}$$

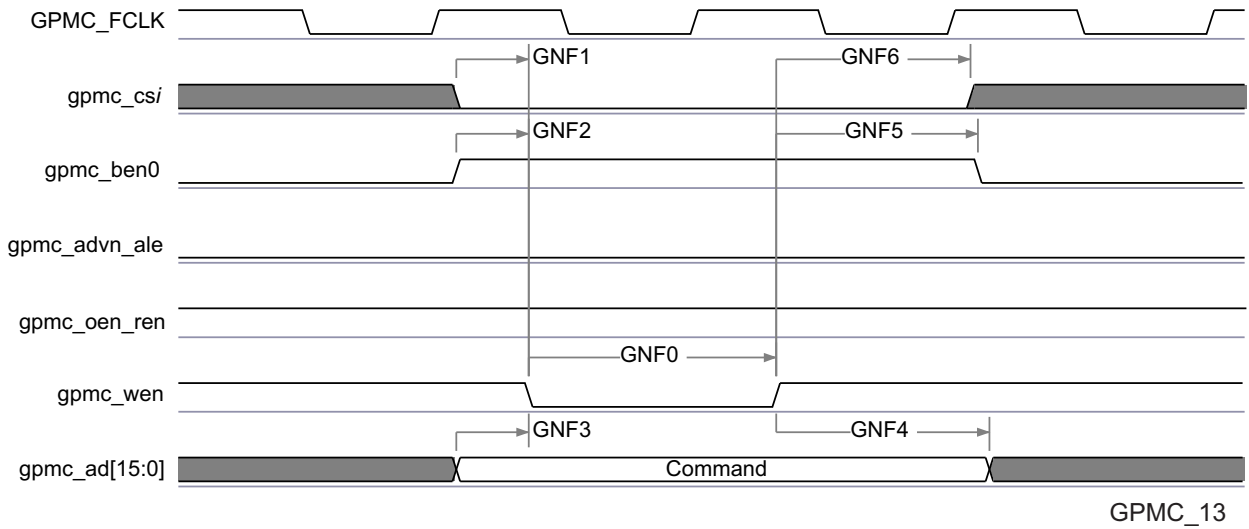

**Figure 5-35. GPMC / NAND Flash - Command Latch Cycle Timing<sup>(1)</sup>**

(1) In gpmc\_csi, i = 0 to 7.

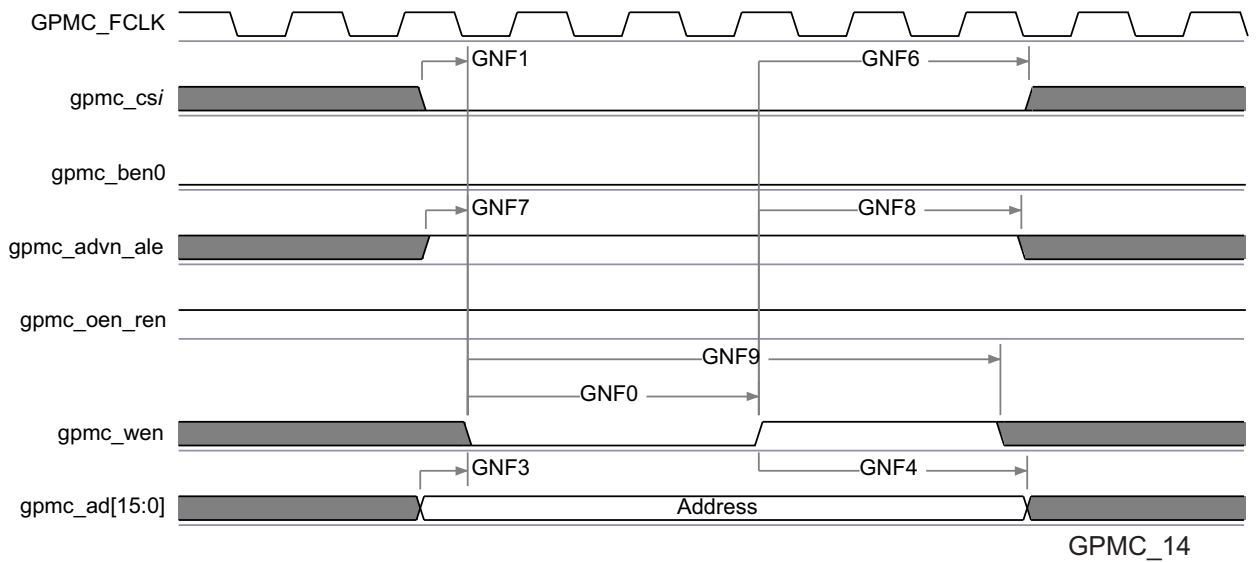

**Figure 5-36. GPMC / NAND Flash - Address Latch Cycle Timing<sup>(1)</sup>**

(1) In gpmc\_csi, i = 0 to 7.



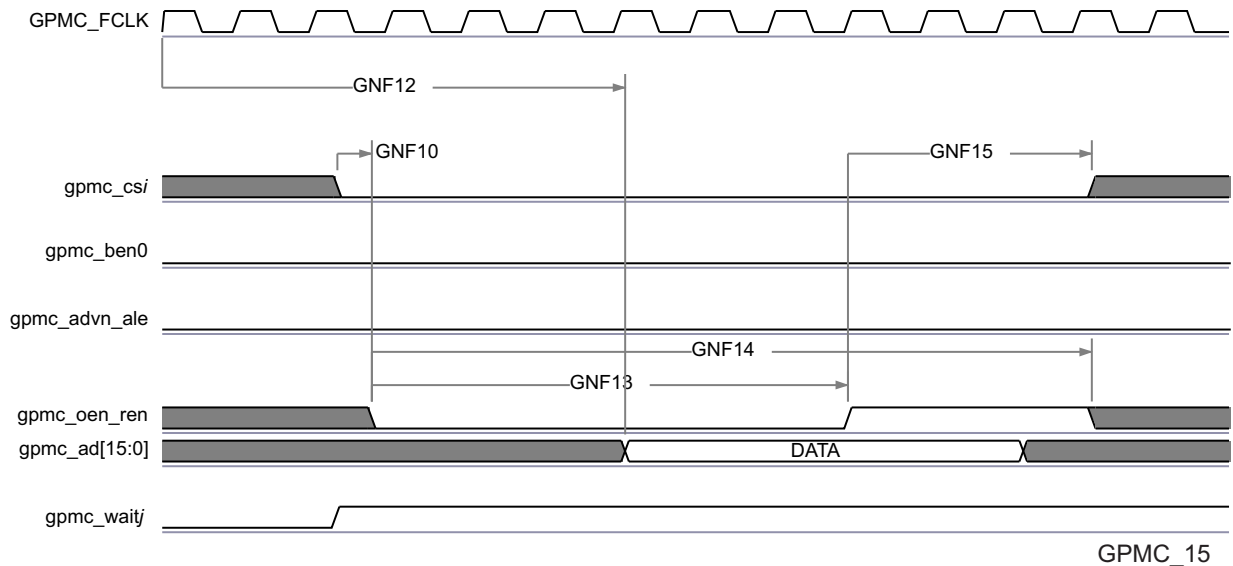

**Figure 5-37. GPMC / NAND Flash - Data Read Cycle Timing<sup>(1)(2)(3)</sup>**

- (1) GNF12 parameter illustrates amount of time required to internally sample input Data. It is expressed in number of GPMC functional clock cycles. From start of read cycle and after GNF12 functional clock cycles, input data will be internally sampled by active functional clock edge. GNF12 value must be stored inside AccessTime register bits field.
- (2) GPMC\_FCLK is an internal clock (GPMC functional clock) not provided externally.
- (3) In gpmc\_csi, i = 0 to 7. In gpmc\_waitj, j = 0 to 1.

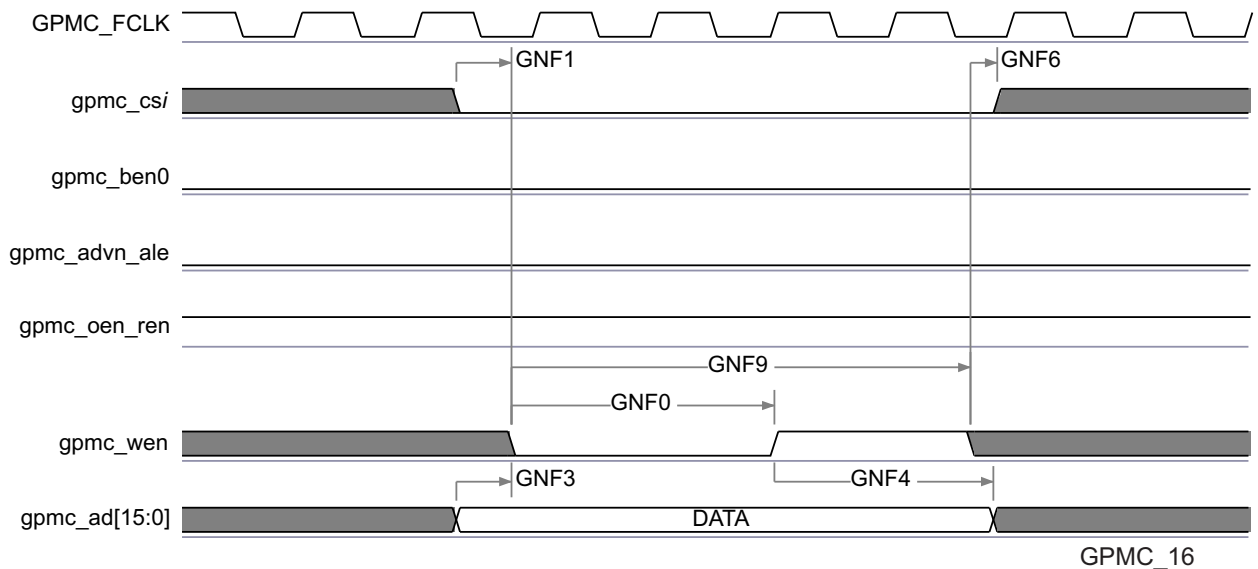

**Figure 5-38. GPMC / NAND Flash - Data Write Cycle Timing<sup>(1)</sup>**

- (1) In gpmc\_csi, i = 0 to 7.

**NOTE**

To configure the desired virtual mode the user must set MODESELECT bit and DELAYMODE bitfield for each corresponding pad control register.

The pad control registers are presented in [Table 4-27](#) and described in Device TRM, *Control Module Chapter*.

Virtual IO Timings Modes must be used to ensure some IO timings for GPMC. See [Table 5-28 Modes Summary](#) for a list of IO timings requiring the use of Virtual IO Timings Modes. See [Table 5-54 Virtual Functions Mapping for GPMC](#) for a definition of the Virtual modes.

[Table 5-54](#) presents the values for DELAYMODE bitfield.

**Table 5-54. Virtual Functions Mapping for GPMC**

BALL	BALL NAME	Delay Mode Value	MUXMODE								
			GPMC_VIRTUAL1	0	1	2	3	5	6	14 <sup>(1)</sup>	14 <sup>(1)</sup>
H5	gpmc_advn_al e	15	gpmc_advn_al e	gpmc_cs6			gpmc_wait1	gpmc_a2	gpmc_a23		
B4	gpmc_ad15	13	gpmc_ad15								
B1	gpmc_ad6	13	gpmc_ad6								
E1	gpmc_ad2	13	gpmc_ad2								
E10	vin2a_d9	9								gpmc_a25	
G6	gpmc_wen	15	gpmc_wen								
A3	gpmc_ad14	13	gpmc_ad14								
H3	gpmc_a13	15	gpmc_a13								
K4	gpmc_a8	14	gpmc_a8								
H4	gpmc_a14	15	gpmc_a14								
D1	gpmc_ad4	13	gpmc_ad4								
A5	gpmc_a26	15	gpmc_a26			gpmc_a20					
F1	gpmc_ad0	13	gpmc_ad0								
F6	gpmc_wait0	15	gpmc_wait0								
C10	vin2a_d11	9								gpmc_a23	
E2	gpmc_ad1	13	gpmc_ad1								
C4	gpmc_ad13	13	gpmc_ad13								
L2	gpmc_a2	14	gpmc_a2								
D2	gpmc_ad5	13	gpmc_ad5								
B10	vin2a_d8	9								gpmc_a26	
F3	gpmc_cs0	15	gpmc_cs0								
E8	vin2a_hsync0	9								gpmc_a27	
K3	gpmc_a4	14	gpmc_a4								
H2	gpmc_ben0	15	gpmc_ben0	gpmc_cs4							
J1	gpmc_a6	14	gpmc_a6								
K6	gpmc_a15	15	gpmc_a15								
B3	gpmc_ad11	13	gpmc_ad11								

**Table 5-54. Virtual Functions Mapping for GPMC (continued)**

BALL	BALL NAME	Delay Mode Value	MUXMODE									
			GPMC_VIRTUAL1	0	1	2	3	5	6	14 <sup>(1)</sup>	14 <sup>(1)</sup>	
K5	gpmc_a16	15	gpmc_a16									
M2	gpmc_a1	14	gpmc_a1									
D7	gpmc_a24	15	gpmc_a24			gpmc_a18						
B5	gpmc_a23	15	gpmc_a23			gpmc_a17						
C2	gpmc_ad8	13	gpmc_ad8									
A2	gpmc_ad10	13	gpmc_ad10									
C3	gpmc_ad12	13	gpmc_ad12									
E7	gpmc_a20	15	gpmc_a20			gpmc_a14						
D10	vin2a_d10	9								gpmc_a24		
G3	gpmc_cs3	14	gpmc_cs3					gpmc_a1				
G5	gpmc_oen_ren	15	gpmc_oen_ren									
H1	gpmc_a9	14	gpmc_a9									
A6	gpmc_cs1	15	gpmc_cs1			gpmc_a22						
C1	gpmc_ad3	13	gpmc_ad3									
B2	gpmc_ad7	13	gpmc_ad7									
K1	gpmc_a7	14	gpmc_a7									
L1	gpmc_a3	14	gpmc_a3									
H6	gpmc_ben1	15	gpmc_ben1	gpmc_cs5				gpmc_a3				
L4	gpmc_clk	15	gpmc_clk	gpmc_cs7			gpmc_wait1					
C5	gpmc_a22	15	gpmc_a22			gpmc_a16						
G4	gpmc_cs2	15	gpmc_cs2									
C7	vin2a_fld0	11								gpmc_a27	gpmc_a18	
J2	gpmc_a10	14	gpmc_a10									
G1	gpmc_a12	15	gpmc_a12					gpmc_a0				
G2	gpmc_a17	15	gpmc_a17									
K2	gpmc_a5	14	gpmc_a5									
D6	gpmc_a21	15	gpmc_a21			gpmc_a15						
B6	gpmc_a27	15	gpmc_a27			gpmc_a21						
D3	gpmc_ad9	13	gpmc_ad9									
A4	gpmc_a19	15	gpmc_a19			gpmc_a13						
C6	gpmc_a25	15	gpmc_a25			gpmc_a19						
M1	gpmc_a0	14	gpmc_a0									

Table 5-54. Virtual Functions Mapping for GPMC (continued)

BALL	BALL NAME	Delay Mode Value	MUXMODE								
			GPMC_VIRTUAL1	0	1	2	3	5	6	14 <sup>(1)</sup>	14 <sup>(1)</sup>
D8	vin2a_clk0	11								gpmc_a27	gpmc_a17
F2	gpmc_a18	15	gpmc_a18								
L3	gpmc_a11	14	gpmc_a11								

- (1) Some signals listed are virtual functions that present alternate multiplexing options. These virtual functions are controlled via CTRL\_CORE\_ALT\_SELECT\_MUX or CTRL\_CORE\_VIP\_MUX\_SELECT registers. For more information on how to use these options, please refer to Device TRM, Chapter Control Module, Section Pad Configuration Registers.
- 

#### 5.10.6.9 Timers

The device has 16 general-purpose (GP) timers (TIMER1 - TIMER16), two watchdog timers, and a 32-kHz synchronized timer (COUNTER\_32K) that have the following features:

- Dedicated input trigger for capture mode and dedicated output trigger/pulse width modulation (PWM) signal
- Interrupts generated on overflow, compare, and capture
- Free-running 32-bit upward counter
- Supported modes:
  - Compare and capture modes
  - Auto-reload mode
  - Start-stop mode
- On-the-fly read/write register (while counting)

The device has two system watchdog timer (WD\_TIMER1 and WD\_TIMER2) that have the following features:

- Free-running 32-bit upward counter
- On-the-fly read/write register (while counting)
- Reset upon occurrence of a timer overflow condition

The device includes one instance of the 32-bit watchdog timer: WD\_TIMER2, also called the MPU watchdog timer.

The watchdog timer is used to provide a recovery mechanism for the device in the event of a fault condition, such as a non-exiting code loop.

In are presented the specific groupings of signals (IOSET) for use with TIMERS.

---

#### NOTE

For additional information on the Timer Module, see the Device TRM.

---

#### 5.10.6.10 I2C

The device includes 6 inter-integrated circuit (I2C) modules which provide an interface to other devices compliant with Philips Semiconductors Inter-IC bus (I2C-bus™) specification version 2.1. External components attached to this 2-wire serial bus can transmit/receive 8-bit data to/from the device through the I2C module.

---

#### NOTE

Note that, on I2C1 and I2C2, due to characteristics of the open drain IO cells, HS mode is not supported.

---



---

#### NOTE

Inter-integrated circuit i (i=1 to 6) module is also referred to as I2Ci.

---

**NOTE**

For more information, see the Multimaster High-Speed I2C Controller section of the Device TRM.

Table 5-55, Table 5-56 and Figure 5-39 assume testing over the recommended operating conditions and electrical characteristic conditions below.

**Table 5-55. Timing Requirements for I2C Input Timings<sup>(1)</sup>**

NO.	PARAMETER	DESCRIPTION	STANDARD MODE		FAST MODE		UNIT
			MIN	MAX	MIN	MAX	
1	$t_{c(SCL)}$	Cycle time, SCL	10		2.5		$\mu$ s
2	$t_{su(SCLH-SDAL)}$	Setup time, SCL high before SDA low (for a repeated START condition)	4.7		0.6		$\mu$ s
3	$t_{h(SDAL-SCLL)}$	Hold time, SCL low after SDA low (for a START and a repeated START condition)	4		0.6		$\mu$ s
4	$t_{w(SCLL)}$	Pulse duration, SCL low	4.7		1.3		$\mu$ s
5	$t_{w(SCLH)}$	Pulse duration, SCL high	4		0.6		$\mu$ s
6	$t_{su(SDAV-SCLH)}$	Setup time, SDA valid before SCL high	250		100 <sup>(2)</sup>		ns
7	$t_{h(SCLL-SDAV)}$	Hold time, SDA valid after SCL low	0 <sup>(3)</sup>	3.45 <sup>(4)</sup>	0 <sup>(3)</sup>	0.9 <sup>(4)</sup>	$\mu$ s
8	$t_{w(SDAH)}$	Pulse duration, SDA high between STOP and START conditions	4.7		1.3		$\mu$ s
9	$t_{r(SDA)}$	Rise time, SDA		1000	$20 + 0.1C_b$ <sup>(5)</sup>	300 <sup>(3)</sup>	ns
10	$t_{r(SCL)}$	Rise time, SCL		1000	$20 + 0.1C_b$ <sup>(5)</sup>	300 <sup>(3)</sup>	ns
11	$t_{f(SDA)}$	Fall time, SDA		300	$20 + 0.1C_b$ <sup>(5)</sup>	300 <sup>(3)</sup>	ns
12	$t_{f(SCL)}$	Fall time, SCL		300	$20 + 0.1C_b$ <sup>(5)</sup>	300 <sup>(3)</sup>	ns
13	$t_{su(SCLH-SDAH)}$	Setup time, SCL high before SDA high (for STOP condition)	4		0.6		$\mu$ s
14	$t_{w(SP)}$	Pulse duration, spike (must be suppressed)			0	50	ns
15	$C_b$ <sup>(5)</sup>	Capacitive load for each bus line		400		400	pF

- (1) The I2C pins SDA and SCL do not feature fail-safe I/O buffers. These pins could potentially draw current when the device is powered down.
- (2) A Fast-mode I<sup>2</sup>C-bus™ device can be used in a Standard-mode I<sup>2</sup>C-bus system, but the requirement  $t_{su(SDA-SCLH)} \geq 250$  ns must then be met. This will automatically be the case if the device does not stretch the LOW period of the SCL signal, it must output the next data bit to the SDA line  $t_r \text{ max} + t_{su(SDA-SCLH)} = 1000 + 250 = 1250$  ns (according to the Standard-mode I<sup>2</sup>C-Bus Specification) before the SCL line is released.
- (3) A device must internally provide a hold time of at least 300 ns for the SDA signal (referred to the  $V_{IHmin}$  of the SCL signal) to bridge the undefined region of the falling edge of SCL.
- (4) The maximum  $t_{h(SDA-SCLL)}$  has only to be met if the device does not stretch the low period [ $t_{w(SCLL)}$ ] of the SCL signal.
- (5)  $C_b$  = total capacitance of one bus line in pF. If mixed with HS-mode devices, faster fall-times are allowed.

**Table 5-56. Timing Requirements for I<sup>2</sup>C HS-Mode (I<sup>2</sup>C3/4/5/6 Only)<sup>(1)</sup>**

NO.	PARAMETER	DESCRIPTION	$C_b = 100$ pF MAX		$C_b = 400$ pF <sup>(2)</sup>		UNIT
			MIN	MAX	MIN	MAX	
1	$t_{c(SCL)}$	Cycle time, SCL	0.294		0.588		$\mu$ s
2	$t_{su(SCLH-SDAL)}$	Set-up time, SCL high before SDA low (for a repeated START condition)	160		160		ns
3	$t_{h(SDAL-SCLL)}$	Hold time, SCL low after SDA low (for a repeated START condition)	160		160		ns
4	$t_{w(SCLL)}$	LOW period of the SCLH clock	160		320		ns

Table 5-56. Timing Requirements for I<sup>2</sup>C HS-Mode (I<sup>2</sup>C3/4/5/6 Only)<sup>(1)</sup> (continued)

NO.	PARAMETER	DESCRIPTION	C <sub>b</sub> = 100 pF MAX		C <sub>b</sub> = 400 pF <sup>(2)</sup>		UNIT
			MIN	MAX	MIN	MAX	
5	t <sub>w(SCLH)</sub>	HIGH period of the SCLH clock	60		120		ns
6	t <sub>su(SDAV-SCLH)</sub>	Setup time, SDA valid before SCL high	10		10		ns
7	t <sub>h(SCLL-SDAV)</sub>	Hold time, SDA valid after SCL low	0 <sup>(3)</sup>	70	0 <sup>(3)</sup>	150	ns
13	t <sub>su(SCLH-SDAH)</sub>	Setup time, SCL high before SDA high (for a STOP condition)	160		160		ns
14	t <sub>w(SP)</sub>	Pulse duration, spike (must be suppressed)	0	10	0	10	ns
15	C <sub>b</sub> <sup>(2)</sup>	Capacitive load for SDAH and SCLH lines		100		400	pF
16	C <sub>b</sub>	Capacitive load for SDAH + SDA line and SCLH + SCL line		400		400	pF

(1) I<sup>2</sup>C HS-Mode is only supported on I<sup>2</sup>C3/4/5/6. I2C HS-Mode is not supported on I<sup>2</sup>C1/2.

(2) For bus line loads C<sub>b</sub> between 100 and 400 pF the timing parameters must be linearly interpolated.

(3) A device must internally provide a Data hold time to bridge the undefined part between V<sub>IH</sub> and V<sub>IL</sub> of the falling edge of the SCLH signal. An input circuit with a threshold as low as possible for the falling edge of the SCLH signal minimizes this hold time.

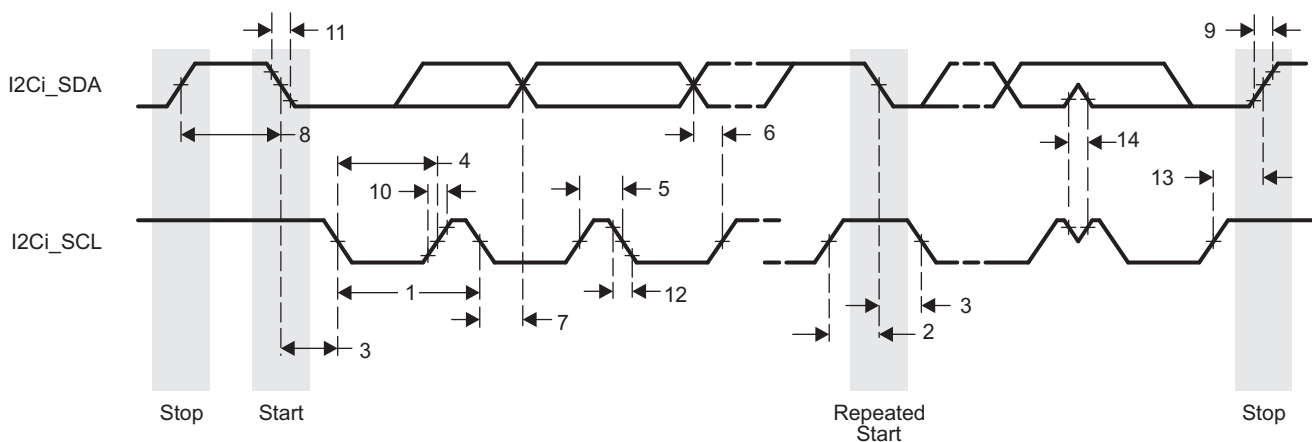

SPRS906\_TIMING\_I2C\_01

Figure 5-39. I2C Receive Timing

Table 5-57 and Figure 5-40 assume testing over the recommended operating conditions and electrical characteristic conditions below.

Table 5-57. Switching Characteristics Over Recommended Operating Conditions for I2C Output Timings<sup>(2)</sup>

NO.	PARAMETER	DESCRIPTION	STANDARD MODE		FAST MODE		UNIT
			MIN	MAX	MIN	MAX	
16	t <sub>c(SCL)</sub>	Cycle time, SCL	10		2.5		μs
17	t <sub>su(SCLH-SDAL)</sub>	Setup time, SCL high before SDA low (for a repeated START condition)	4.7		0.6		μs
18	t <sub>h(SDAL-SCLL)</sub>	Hold time, SCL low after SDA low (for a START and a repeated START condition)	4		0.6		μs
19	t <sub>w(SCLL)</sub>	Pulse duration, SCL low	4.7		1.3		μs
20	t <sub>w(SCLH)</sub>	Pulse duration, SCL high	4		0.6		μs
21	t <sub>su(SDAV-SCLH)</sub>	Setup time, SDA valid before SCL high	250		100		ns
22	t <sub>h(SCLL-SDAV)</sub>	Hold time, SDA valid after SCL low (for I2C bus devices)	0	3.45	0	0.9	μs

**Table 5-57. Switching Characteristics Over Recommended Operating Conditions for I2C Output Timings<sup>(2)</sup> (continued)**

NO.	PARAMETER	DESCRIPTION	STANDARD MODE		FAST MODE		UNIT
			MIN	MAX	MIN	MAX	
23	$t_{w(SDAH)}$	Pulse duration, SDA high between STOP and START conditions	4.7		1.3		$\mu$ s
24	$t_r(SDA)$	Rise time, SDA		1000	$20 + 0.1C_b$ (1) (3)	300 <sup>(3)</sup>	ns
25	$t_r(SCL)$	Rise time, SCL		1000	$20 + 0.1C_b$ (1) (3)	300 <sup>(3)</sup>	ns
26	$t_f(SDA)$	Fall time, SDA		300	$20 + 0.1C_b$ (1) (3)	300 <sup>(3)</sup>	ns
27	$t_f(SCL)$	Fall time, SCL		300	$20 + 0.1C_b$ (1) (3)	300 <sup>(3)</sup>	ns
28	$t_{su}(SCLH-SDAH)$	Setup time, SCL high before SDA high (for STOP condition)	4		0.6		$\mu$ s
29	$C_p$	Capacitance for each I2C pin		10		10	pF

(1)  $C_b$  = total capacitance of one bus line in pF. If mixed with HS-mode devices, faster fall-times are allowed.

(2) Software must properly configure the I2C module registers to achieve the timings shown in this table. See the Device TRM for details.

(3) These timings apply only to I2C1 and I2C2. I2C3, I2C4, I2C5 and I2C6 use standard LVCMOS buffers to emulate open-drain buffers and their rise/fall times should be referenced in the device IBIS model.

#### NOTE

I2C emulation is achieved by configuring the LVCMOS buffers to output Hi-Z instead of driving high when transmitting logic-1.

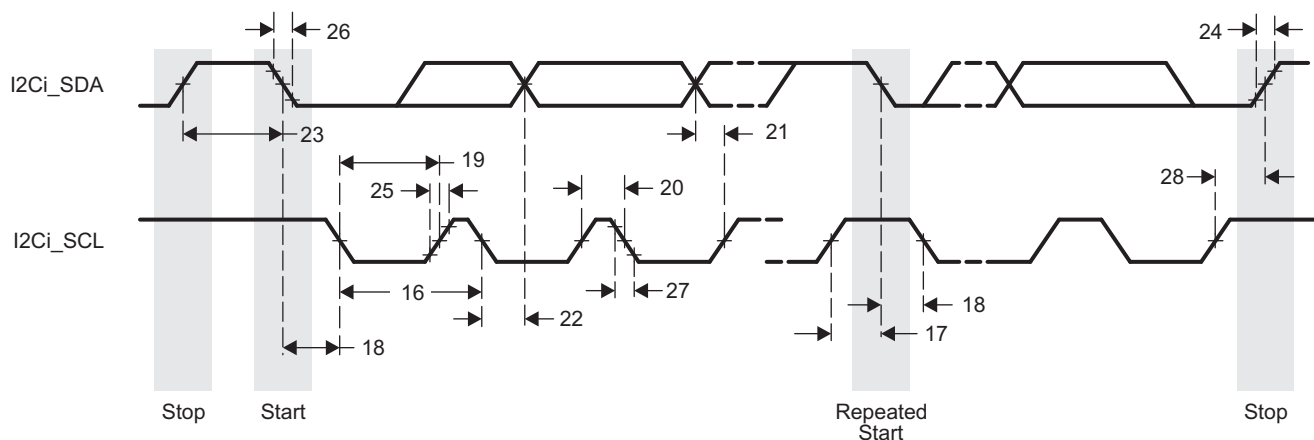

SPRS906\_TIMING\_I2C\_02

**Figure 5-40. I2C Transmit Timing**

In are presented the specific groupings of signals (IOSET) for use with I2C1/2/3/4/5.

#### 5.10.6.11 UART

The UART performs serial-to-parallel conversions on data received from a peripheral device and parallel-to-serial conversion on data received from the CPU. There are 10 UART modules in the device. Only one UART supports IrDA features. Each UART can be used for configuration and data exchange with a number of external peripheral devices or interprocessor communication between devices

The UART<sub>i</sub> (where  $i = 1$  to 10) include the following features:

- 16C750 compatibility



- 64-byte FIFO buffer for receiver and 64-byte FIFO for transmitter
- Baud generation based on programmable divisors N (where N = 1...16 384) operating from a fixed functional clock of 48 MHz or 192 MHz
- Break character detection and generation
- Configurable data format:
  - Data bit: 5, 6, 7, or 8 bits
  - Parity bit: Even, odd, none
  - Stop-bit: 1, 1.5, 2 bit(s)
- Flow control: Hardware (RTS/CTS) or software (XON/XOFF)
- Only UART1 module has extended modem control signals (CD, RI, DTR, DSR)
- Only UART3 supports IrDA

**NOTE**

For more information, see the UART section of the Device TRM.

Table 5-58, Table 5-59 and Figure 5-41 assume testing over the recommended operating conditions and electrical characteristic conditions below.

**Table 5-58. Timing Requirements for UART**

NO.	PARAMETER	DESCRIPTION	MIN	MAX	UNIT
4	$t_{w(RX)}$	Pulse width, receive data bit, 15/30/100pF high or low	$0.96U^{(1)}$	$1.05U^{(1)}$	ns
5	$t_{w(CTS)}$	Pulse width, receive start bit, 15/30/100pF high or low	$0.96U^{(1)}$	$1.05U^{(1)}$	ns
	$t_{d(RTS-TX)}$	Delay time, transmit start bit to transmit data	$P^{(2)}$		ns
	$t_{d(CTS-TX)}$	Delay time, receive start bit to transmit data	$P^{(2)}$		ns

(1) U = UART baud time = 1/programmed baud rate

(2) P = Clock period of the reference clock (FCLK, usually 48 MHz or 192MHz).

**Table 5-59. Switching Characteristics Over Recommended Operating Conditions for UART**

NO.	PARAMETER	DESCRIPTION	MIN	MAX	UNIT
	$f_{(baud)}$	Maximum programmable baud rate			MHz
		15 pF		12	
		30 pF		0.23	
		100 pF		0.115	
2	$t_{w(TX)}$	Pulse width, transmit data bit, 15/30/100 pF high or low	$U - 2^{(1)}$	$U + 2^{(1)}$	ns
3	$t_{w(RTS)}$	Pulse width, transmit start bit, 15/30/100 pF high or low	$U - 2^{(1)}$	$U + 2^{(1)}$	ns

(1) U = UART baud time = 1/programmed baud rate

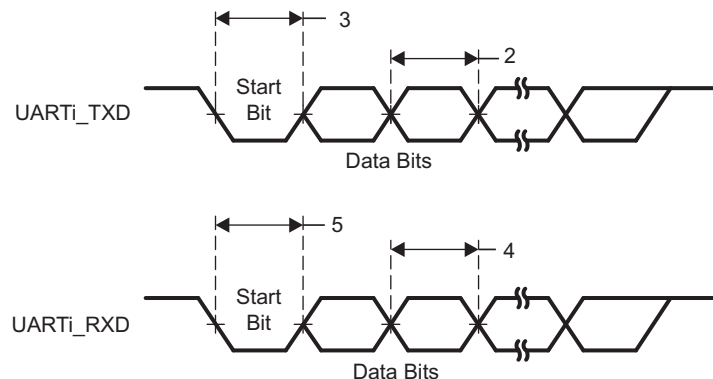

SPRS906\_TIMING\_UART\_01

**Figure 5-41. UART Timing**

In are presented the specific groupings of signals (IOSET) for use with UART.

### 5.10.6.12 McSPI

The McSPI is a master/slave synchronous serial bus. There are four separate McSPI modules (SPI1, SPI2, SPI3, and SPI4) in the device. All these four modules support up to four external devices (four chip selects) and are able to work as both master and slave.

The McSPI modules include the following main features:

- Serial clock with programmable frequency, polarity, and phase for each channel
- Wide selection of SPI word lengths, ranging from 4 to 32 bits
- Up to four master channels, or single channel in slave mode
- Master multichannel mode:
  - Full duplex/half duplex
  - Transmit-only/receive-only/transmit-and-receive modes
  - Flexible input/output (I/O) port controls per channel
  - Programmable clock granularity
  - SPI configuration per channel. This means, clock definition, polarity enabling and word width
- Power management through wake-up capabilities
- Programmable timing control between chip select and external clock generation
- Built-in FIFO available for a single channel.
- Each SPI module supports multiple chip select pins `spim_cs[i]`, where  $i = 1$  to 4.

---

#### NOTE

For more information, see the Serial Communication Interface section of the device TRM.

---

#### NOTE

The McSPIm module ( $m = 1$  to 4) is also referred to as SPIm.

---

#### CAUTION

The I/O timings provided in this section are applicable for all combinations of signals for SPI1 and SPI2. However, the timings are valid only for SPI3 and SPI4 if signals within a single IOSET are used. The IOSETS are defined in [Table 5-62](#).

[Table 5-60](#), [Figure 5-42](#) and [Figure 5-43](#) present Timing Requirements for McSPI - Master Mode.

**Table 5-60. Timing Requirements for SPI - Master Mode <sup>(1)</sup>**

NO.	PARAMETER	DESCRIPTION	MODE	MIN	MAX	UNIT
SM1	$t_c(\text{SPICLK})$	Cycle time, <code>spi_sclk</code> <sup>(1)</sup> <sup>(2)</sup>	SPI1/2/3/ 4	20.8 <sup>(3)</sup>		ns
SM2	$t_w(\text{SPICLK}_L)$	Typical Pulse duration, <code>spi_sclk</code> low <sup>(1)</sup>		$0.5 \times P-1$ <sup>(4)</sup>		ns
SM3	$t_w(\text{SPICLK}_H)$	Typical Pulse duration, <code>spi_sclk</code> high <sup>(1)</sup>		$0.5 \times P-1$ <sup>(4)</sup>		ns
SM4	$t_{su}(\text{MISO-SPICLK})$	Setup time, <code>spi_d[x]</code> valid before <code>spi_sclk</code> active edge <sup>(1)</sup>		3.5		ns
SM5	$t_h(\text{SPICLK-MISO})$	Hold time, <code>spi_d[x]</code> valid after <code>spi_sclk</code> active edge <sup>(1)</sup>		3.7		ns

**Table 5-60. Timing Requirements for SPI - Master Mode <sup>(1)</sup> (continued)**

NO.	PARAMETER	DESCRIPTION	MODE	MIN	MAX	UNIT
SM6	$t_{d(SPICLK-SIMO)}$	Delay time, spi_sclk active edge to spi_d[x] transition <sup>(1)</sup>	SPI1	-3.57	4.1	ns
			SPI2	-3.9	3.6	ns
			SPI3	-4.9	4.7	ns
			SPI4	-4.3	4.5	ns
SM7	$t_{d(CS-SIMO)}$	Delay time, spi_cs[x] active edge to spi_d[x] transition			5	ns
SM8	$t_{d(CS-SPICLK)}$	Delay time, spi_cs[x] active to spi_sclk first edge <sup>(1)</sup>	MASTER_PHA0 <sup>(5)</sup>	B-4.2 <sup>(6)</sup>		ns
			MASTER_PHA1 <sup>(5)</sup>	A-4.2 <sup>(7)</sup>		ns
SM9	$t_{d(SPICLK-CS)}$	Delay time, spi_sclk last edge to spi_cs[x] inactive <sup>(1)</sup>	MASTER_PHA0 <sup>(5)</sup>	A-4.2 <sup>(7)</sup>		ns
			MASTER_PHA1 <sup>(5)</sup>	B-4.2 <sup>(6)</sup>		ns

(1) This timing applies to all configurations regardless of SPI\_CLK polarity and which clock edges are used to drive output data and capture input data.

(2) Related to the SPI\_CLK maximum frequency.

(3) 20.8ns cycle time = 48MHz

(4) P = SPICLK period.

(5) SPI\_CLK phase is programmable with the PHA bit of the SPI\_CH(i)CONF register.

(6)  $B = (TCS + 0.5) \times TSPICLKREF \times Fratio$ , where TCS is a bit field of the SPI\_CH(i)CONF register and Fratio = Even  $\geq 2$ .

(7) When P = 20.8 ns,  $A = (TCS + 1) \times TSPICLKREF$ , where TCS is a bit field of the SPI\_CH(i)CONF register. When P > 20.8 ns,  $A = (TCS + 0.5) \times Fratio \times TSPICLKREF$ , where TCS is a bit field of the SPI\_CH(i)CONF register.

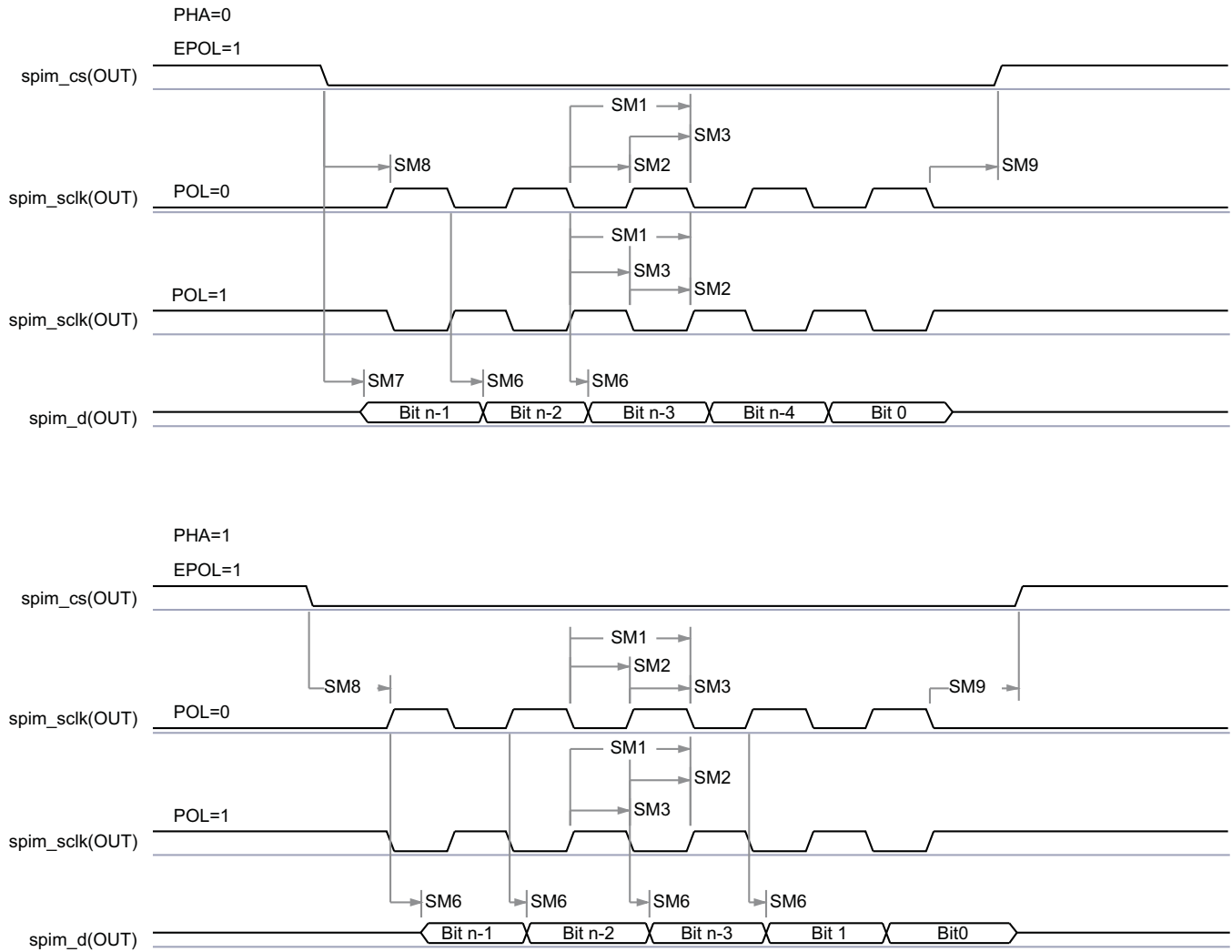

SPRS906\_TIMING\_McSPI\_01

**Figure 5-42. McSPI - Master Mode Transmit**

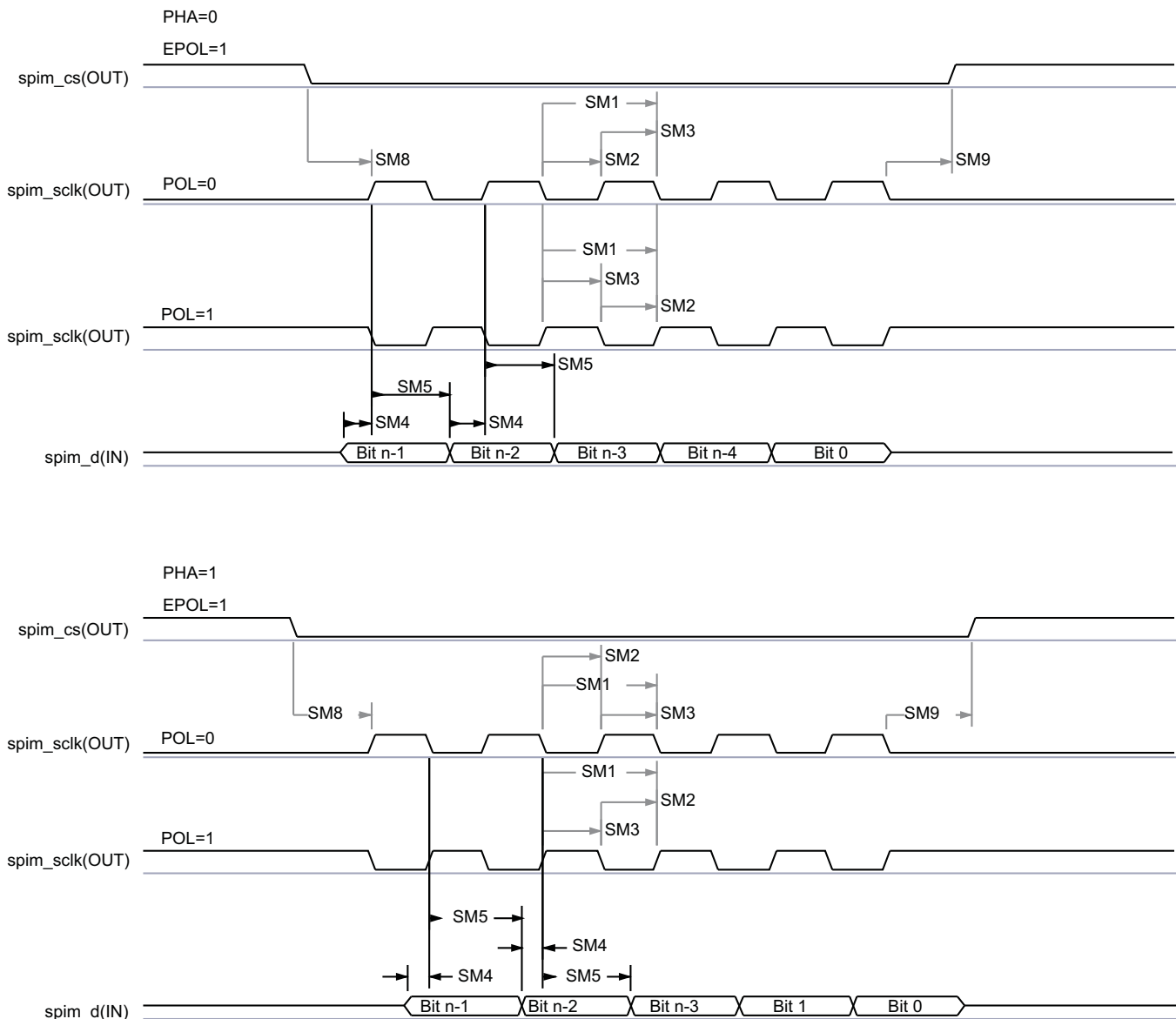

SPRS906\_TIMING\_McSPI\_02

Figure 5-43. McSPI - Master Mode Receive

Table 5-61, Figure 5-44 and Figure 5-45 present Timing Requirements for McSPI - Slave Mode.

Table 5-61. Timing Requirements for SPI - Slave Mode

NO.	PARAMETER	DESCRIPTION	MODE	MIN	MAX	UNIT
SS1 <sup>(1)</sup>	$t_c(\text{SPICLK})$	Cycle time, spi_sclk		62.5 <sup>(2)</sup> <sup>(3)</sup>		ns
SS2 <sup>(1)</sup>	$t_w(\text{SPICLK}_L)$	Typical Pulse duration, spi_sclk low		0.45 × P <sup>(4)</sup>		ns
SS3 <sup>(1)</sup>	$t_w(\text{SPICLK}_H)$	Typical Pulse duration, spi_sclk high		0.45 × P <sup>(4)</sup>		ns
SS4 <sup>(1)</sup>	$t_{su}(\text{SIMO-SPICLK})$	Setup time, spi_d[x] valid before spi_sclk active edge		5		ns
SS5 <sup>(1)</sup>	$t_h(\text{SPICLK-SIMO})$	Hold time, spi_d[x] valid after spi_sclk active edge		5		ns
SS6 <sup>(1)</sup>	$t_d(\text{SPICLK-SOMI})$	Delay time, spi_sclk active edge to mcspi_somi transition	SPI1/2/3	2	26.6	ns
			SPI4	2	20.1	ns

**Table 5-61. Timing Requirements for SPI - Slave Mode (continued)**

NO.	PARAMETER	DESCRIPTION	MODE	MIN	MAX	UNIT
SS7 <sup>(5)</sup>	$t_{d(CS-SOMI)}$	Delay time, spi_cs[x] active edge to mcspi_somi transition			20.95	ns
SS8 <sup>(1)</sup>	$t_{su(CS-SPICLK)}$	Setup time, spi_cs[x] valid before spi_sclk first edge		5		ns
SS9 <sup>(1)</sup>	$t_{h(SPICLK-CS)}$	Hold time, spi_cs[x] valid after spi_sclk last edge	SPI1/2	5		ns
			SPI3	7.5		ns
			SPI4	6		ns

- (1) This timing applies to all configurations regardless of SPI\_CLK polarity and which clock edges are used to drive output data and capture input data.
- (2) When operating the SPI interface in RX-only mode, the minimum Cycle time is 26ns (38.4MHz)
- (3) 62.5ns Cycle time = 16 MHz
- (4) P = SPICLK period.
- (5) PHA = 0; SPI\_CLK phase is programmable with the PHA bit of the SPI\_CH(i)CONF register.

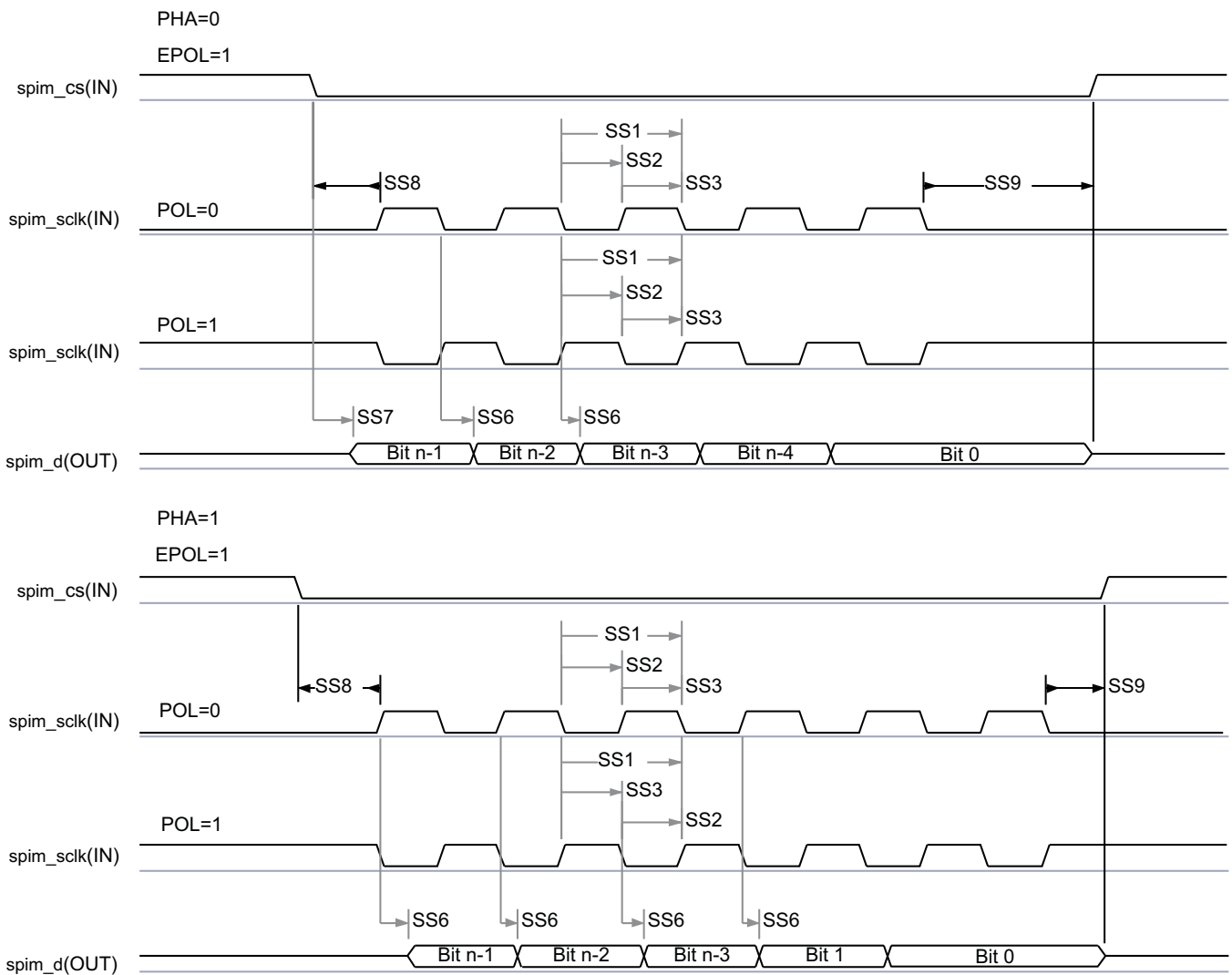

SPRS906\_TIMING\_McSPI\_03

**Figure 5-44. McSPI - Slave Mode Transmit**

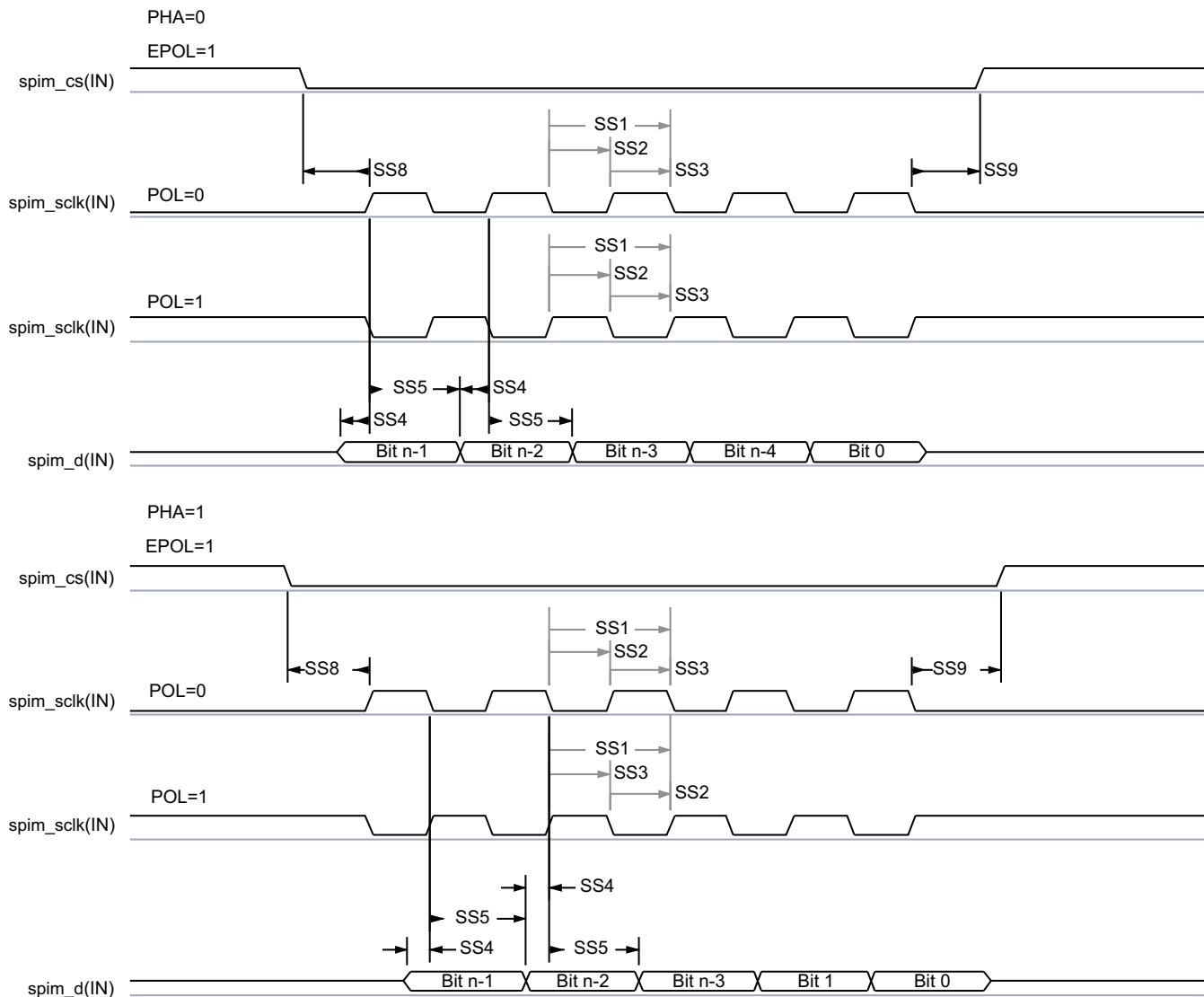

SPRS906\_TIMING\_McSPI\_04

Figure 5-45. McSPI - Slave Mode Receive

In Table 5-62 are presented the specific groupings of signals (IOSET) for use with SPI3 and SPI4.

Table 5-62. McSPI3/4 IOSETs

SIGNALS	IOSET1		IOSET2		IOSET3		IOSET4		IOSET5	
	BALL	MUX	BALL	MUX	BALL	MUX	BALL	MUX	BALL	MUX
<b>McSPI3</b>										
spi3_cs0			T5	7	B18	3	D23	2	AA3	1
spi3_cs1			W2	1	A19	3			W2	1
spi3_d0			T4	7	B16	3	A24	2	AA2	1
spi3_d1			N6	7	B17	3	B25	2	Y4	1
spi3_sclk			N5	7	A18	3	C23	2	Y1	1
<b>McSPI4</b>										
spi4_cs0	L3	8	B9	8	R1	7	AC4	2	AB1	1
spi4_cs1	G1	8	G1	8	N6	8	N6	8	N6	8
spi4_cs2	H3	8	H3	8	T4	8	T4	8	T4	8

**Table 5-62. McSPI3/4 IOSETs (continued)**

SIGNALS	IOSET1		IOSET2		IOSET3		IOSET4		IOSET5	
	BALL	MUX	BALL	MUX	BALL	MUX	BALL	MUX	BALL	MUX
spi4_cs3	H4	8	H4	8	T5	8	T5	8	T5	8
spi4_d0	J2	8	C8	8	R2	7	AA5	2	AA4	1
spi4_d1	H1	8	B8	8	P3	7	U6	2	AA1	1
spi4_sclk	K4	8	E8	8	P4	7	AC3	2	Y3	1

**5.10.6.13 QSPI**

The Quad SPI (QSPI) module is a type of SPI module that allows single, dual or quad read access to external SPI devices. This module has a memory mapped register interface, which provides a direct interface for accessing data from external SPI devices and thus simplifying software requirements. It works as a master only. There is one QSPI module in the device and it is primary intended for fast booting from quad-SPI flash memories.

General SPI features:

- Programmable clock divider
- Six pin interface (DCLK, CS\_N, DOUT, DIN, QDIN1, QDIN2)
- 4 external chip select signals
- Support for 3-, 4- or 6-pin SPI interface
- Programmable CS\_N to DOUT delay from 0 to 3 DCLKs
- Programmable signal polarities
- Programmable active clock edge
- Software controllable interface allowing for any type of SPI transfer

**NOTE**

For more information, see the Quad Serial Peripheral Interface section of the Device TRM.

**CAUTION**

The I/O Timings provided in this section are only valid when all QSPI Chip Selects used in a system are configured to use the same Clock Mode (either Clock Mode 0 or Clock Mode 3).

**CAUTION**

The I/O Timings provided in this section are valid only for some QSPI usage modes when the corresponding Virtual I/O Timings or Manual I/O Timings are configured as described in the tables found in this section.

[Table 5-63](#) and [Table 5-64](#) Present Timing and Switching Characteristics for Quad SPI Interface.

**Table 5-63. Switching Characteristics for QSPI**

NO.	PARAMETER	DESCRIPTION	MODE	MIN	MAX	UNIT
Q1	$t_{c(SCLK)}$	Cycle time, sclk	Default Timing Mode, Clock Mode 0	11.71		ns
			Default Timing Mode, Clock Mode 3	20.8		ns



Table 5-63. Switching Characteristics for QSPI (continued)

NO.	PARAMETER	DESCRIPTION	MODE	MIN	MAX	UNIT
Q2	$t_{w(SCLKL)}$	Pulse duration, sclk low		$Y \times P-1$ <sup>(1)</sup>		ns
Q3	$t_{w(SCLKH)}$	Pulse duration, sclk high		$Y \times P-1$ <sup>(1)</sup>		ns
Q4	$t_d(CS-SCLK)$	Delay time, sclk falling edge to cs active edge, CS3:0	Default Timing Mode	$-M \times P-1.6$ <sup>(2)</sup> <sup>(3)</sup>	$-M \times P+2.6$ <sup>(2)</sup> <sup>(3)</sup>	ns
Q5	$t_d(SCLK-CS)$	Delay time, sclk falling edge to cs inactive edge, CS3:0	Default Timing Mode	$N \times P-1.6$ <sup>(2)</sup> <sup>(3)</sup>	$N \times P+2.6$ <sup>(2)</sup> <sup>(3)</sup>	ns
Q6	$t_d(SCLK-D0)$	Delay time, sclk falling edge to d[0] transition	Default Timing Mode	-1.6	2.6	ns
Q7	$t_{ena}(CS-D0LZ)$	Enable time, cs active edge to d[0] driven (lo-z)		-P-3.5	-P+2.5	ns
Q8	$t_{dis}(CS-D0Z)$	Disable time, cs active edge to d[0] tri-stated (hi-z)		-P-2.5	-P+2.0	ns
Q9	$t_d(SCLK-D0)$	Delay time, sclk first falling edge to first d[0] transition	PHA=0 Only, Default Timing Mode	-1.6- $P$ <sup>(2)</sup>	$2.6-P$ <sup>(2)</sup>	ns

(1) The Y parameter is defined as follows:

If DCLK\_DIV is 0 or ODD then, Y equals 0.5.

If DCLK\_DIV is EVEN then, Y equals  $(DCLK\_DIV/2) / (DCLK\_DIV+1)$ .

For best performance, it is recommended to use a DCLK\_DIV of 0 or ODD to minimize the duty cycle distortion. The HSDIVIDER on CLKOUTX2\_H13 output of DPLL\_PER can be used to achieve the desired clock divider ratio. All required details about clock division factor DCLK\_DIV can be found in the device-specific Technical Reference Manual.

(2) P = SCLK period.

(3) M=QSPI\_SPI\_DC\_REG.DDx + 1 when Clock Mode 0.

M=QSPI\_SPI\_DC\_REG.DDx when Clock Mode 3.

N = 2 when Clock Mode 0.

N = 3 when Clock Mode 3.

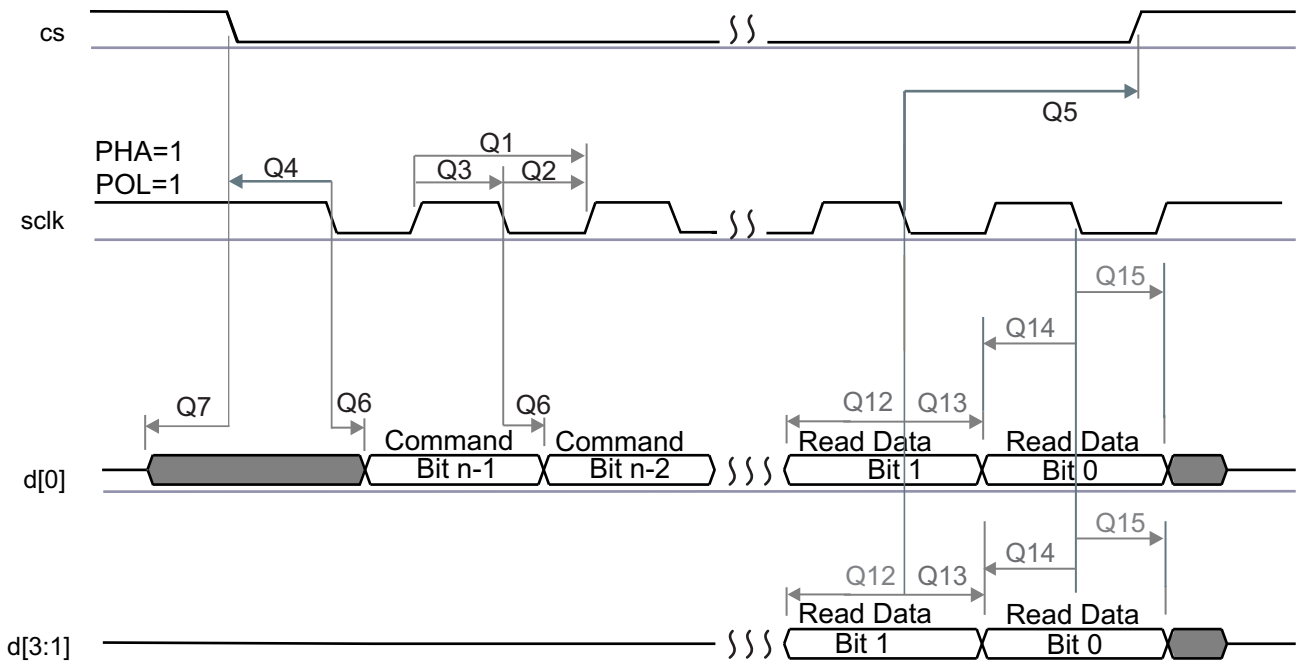

SPRS91V\_QSPI\_01

Figure 5-46. QSPI Read (Clock Mode 3)

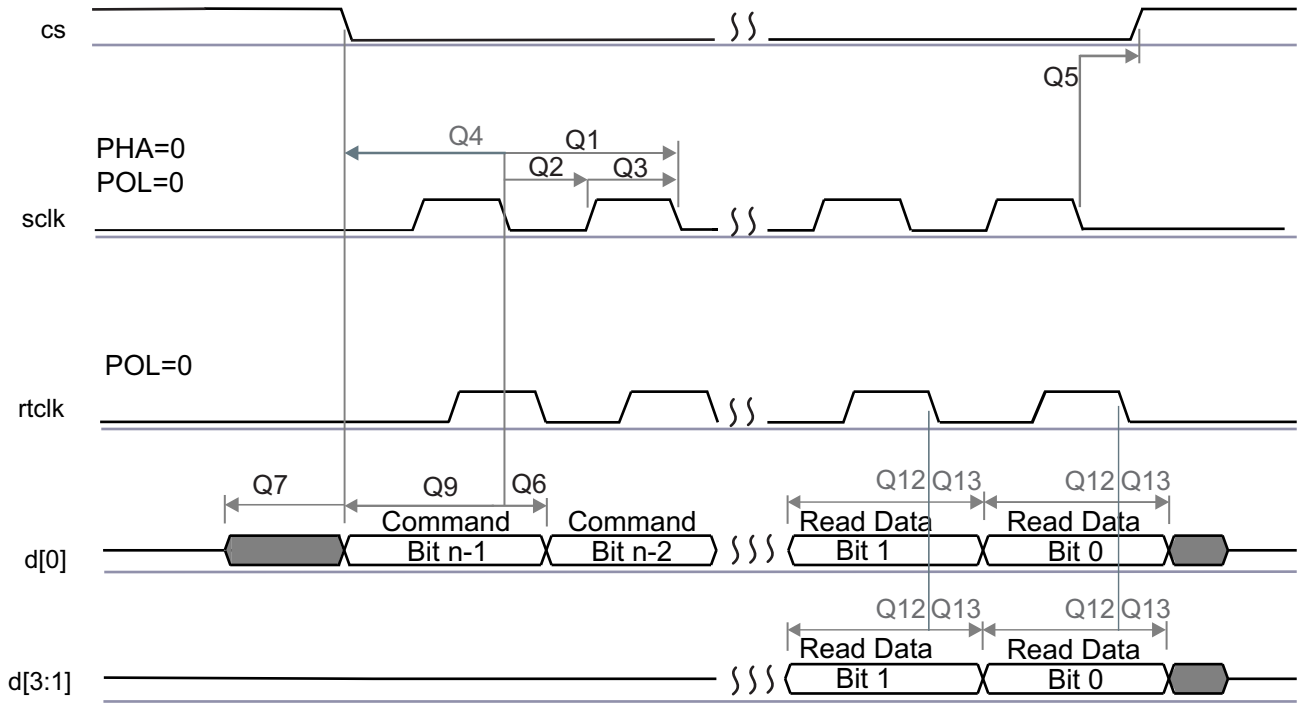

SPRS91v\_QSPI\_02

Figure 5-47. QSPI Read (Clock Mode 0)

**CAUTION**

The I/O Timings provided in this section are valid only for some QSPI usage modes when the corresponding Virtual I/O Timings or Manual I/O Timings are configured as described in the tables found in this section.

Table 5-64. Timing Requirements for QSPI<sup>(3)(2)</sup>

NO.	PARAMETER	DESCRIPTION	MODE	MIN	MAX	UNIT
Q2	$t_{su}(D-RTCLK)$	Setup time, d[3:0] valid before falling rclk edge	Default Timing Mode, Clock Mode 0	4.6		ns
	$t_{su}(D-SCLK)$	Setup time, d[3:0] valid before falling sclk edge	Default Timing Mode, Clock Mode 3	12.3		ns
Q13	$t_h(RTCLK-D)$	Hold time, d[3:0] valid after falling rclk edge	Default Timing Mode, Clock Mode 0	-0.1		ns
	$t_h(SCLK-D)$	Hold time, d[3:0] valid after falling sclk edge	Default Timing Mode, Clock Mode 3	0.1		ns
Q14	$t_{su}(D-SCLK)$	Setup time, final d[3:0] bit valid before final falling sclk edge	Default Timing Mode, Clock Mode 3	12.3-P <sup>(1)</sup>		ns
Q15	$t_h(SCLK-D)$	Hold time, final d[3:0] bit valid after final falling sclk edge	Default Timing Mode, Clock Mode 3	0.1+P <sup>(1)</sup>		ns

- (1) P = SCLK period.
- (2) Clock Modes 1 and 2 are not supported.
- (3) The Device captures data on the falling clock edge in Clock Mode 0 and 3, as opposed to the traditional rising clock edge. Although non-standard, the falling-edge-based setup and hold time timings have been designed to be compatible with standard SPI devices that launch data on the falling edge in Clock Modes 0 and 3.

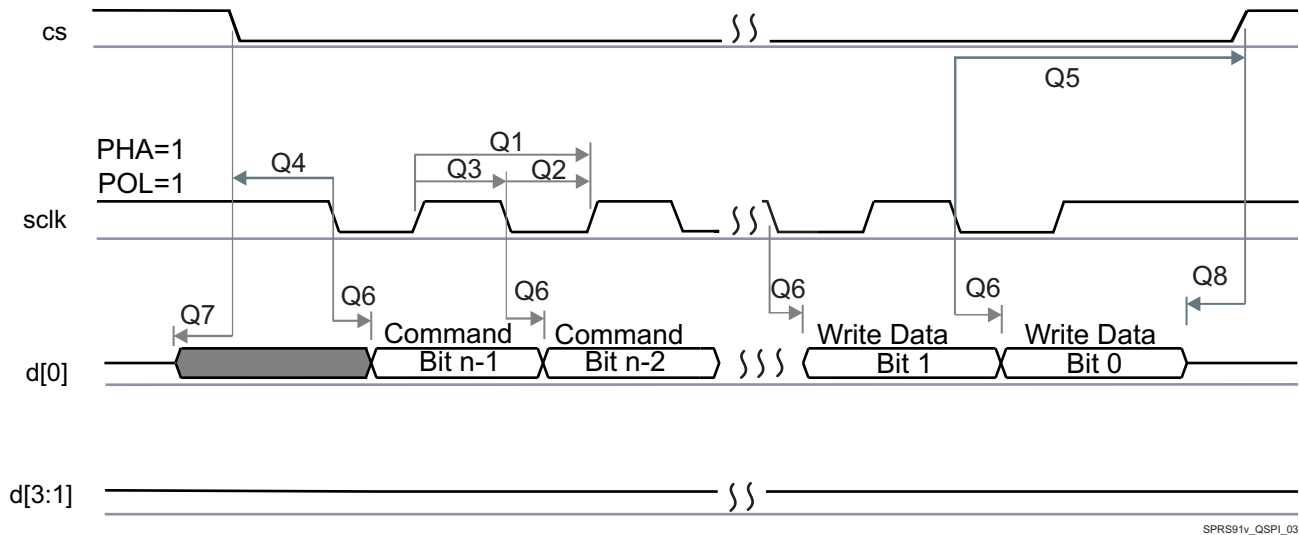

Figure 5-48. QSPI Write (Clock Mode 3)

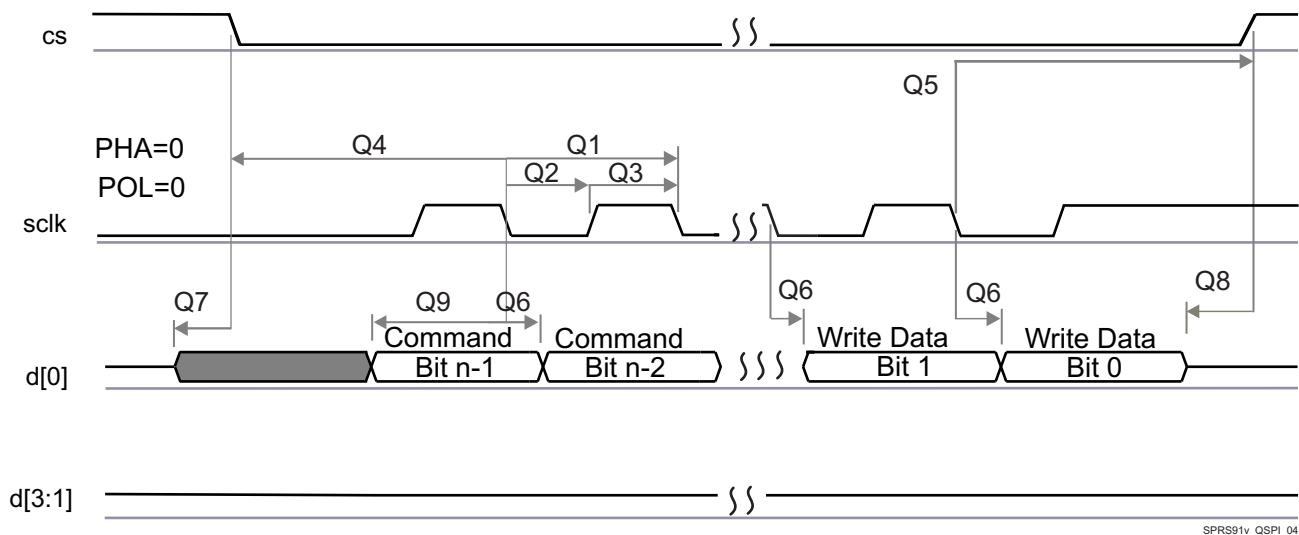

Figure 5-49. QSPI Write (Clock Mode 0)

**CAUTION**

The I/O Timings provided in this section are valid only for some QSPI usage modes when the corresponding Virtual I/O Timings or Manual I/O Timings are configured as described in the tables found in this section.

**NOTE**

To configure the desired Manual IO Timing Mode the user must follow the steps described in section Manual IO Timing Modes of the Device TRM.

The associated registers to configure are listed in the **CFG REGISTER** column. For more information see the Control Module chapter in the Device TRM.

Manual IO Timings Modes must be used to ensure some IO timings for QSPI. See [Table 5-28 Modes Summary](#) for a list of IO timings requiring the use of Manual IO Timings Modes. See [Table 5-65 Manual Functions Mapping for QSPI](#) for a definition of the Manual modes.

[Table 5-65](#) lists the A\_DELAY and G\_DELAY values needed to calculate the correct values to be set in the CFG\_x registers.

**Table 5-65. Manual Functions Mapping for QSPI**

BALL	BALL NAME	QSPI1_MANUAL1		CFG REGISTER	MUXMODE
		A_DELAY (ps)	G_DELAY (ps)		1
L1	gpmc_a3	0	0	CFG_GPMC_A3_OUT	qspi1_cs2
K3	gpmc_a4	0	0	CFG_GPMC_A4_OUT	qspi1_cs3
H3	gpmc_a13	0	0	CFG_GPMC_A13_IN	qspi1_rtclk
H4	gpmc_a14	2247	1186	CFG_GPMC_A14_IN	qspi1_d3
K6	gpmc_a15	2176	1197	CFG_GPMC_A15_IN	qspi1_d2
K5	gpmc_a16	2229	1268	CFG_GPMC_A16_IN	qspi1_d0
K5	gpmc_a16	0	0	CFG_GPMC_A16_OUT	qspi1_d0
G2	gpmc_a17	2251	1217	CFG_GPMC_A17_IN	qspi1_d1
F2	gpmc_a18	0	0	CFG_GPMC_A18_OUT	qspi1_sclk
G4	gpmc_cs2	0	0	CFG_GPMC_CS2_OUT	qspi1_cs0
G3	gpmc_cs3	0	0	CFG_GPMC_CS3_OUT	qspi1_cs1

**5.10.6.14 McASP**

The multichannel audio serial port (McASP) functions as a general-purpose audio serial port optimized for the needs of multichannel audio applications. The McASP is useful for time-division multiplexed (TDM) stream, Inter-Integrated Sound (I2S) protocols, and intercomponent digital audio interface transmission (DIT).

The device have integrated 8 McASP modules (McASP1-McASP8) with:

- McASP1 and McASP2 modules supporting 16 channels with independent TX/RX clock/sync domain
- McASP3 through McASP7 modules supporting 4 channels with independent TX/RX clock/sync domain
- McASP8 module supporting 2 channels with independent TX/RX clock/sync domain

**NOTE**

For more information, see the Serial Communication Interface section of the Device TRM.

**CAUTION**

The I/O Timings provided in this section are valid only for some McASP usage modes when the corresponding Virtual I/O Timings or Manual I/O Timings are configured as described in the tables found in this section.

[Table 5-66](#), [Table 5-67](#), [Table 5-68](#) and [Figure 5-50](#) present Timing Requirements for McASP1 to McASP8

**Table 5-66. Timing Requirements for McASP1<sup>(1)</sup>**

NO.	PARAMETER	DESCRIPTION	MODE	MIN	MAX	UNIT
1	$t_c(\text{AHCLKX})$	Cycle time, AHCLKX		20		ns
2	$t_w(\text{AHCLKX})$	Pulse duration, AHCLKX high or low		0.35P <sup>(2)</sup>		ns
3	$t_c(\text{ACLKR/X})$	Cycle time, ACLKR/X		20		ns
4	$t_w(\text{ACLKR/X})$	Pulse duration, ACLKR/X high or low		0.5R - 3 <sup>(3)</sup>		ns
5	$t_{su}(\text{AFSRX-ACLK})$	Setup time, AFSRX input valid before ACLKR/X	ACLKR/X int	20.5		ns
			ACLKR/X ext in ACLKR/X ext out	4		ns
6	$t_h(\text{ACLK-AFSRX})$	Hold time, AFSRX input valid after ACLKR/X	ACLKR/X int	-1		ns
			ACLKR/X ext in ACLKR/X ext out	1.7		ns
7	$t_{su}(\text{AXR-ACLK})$	Setup time, AXR input valid before ACLKR/X	ACLKR/X int	21.6		ns
			ACLKR/X ext in ACLKR/X ext out	11.5		ns
8	$t_h(\text{ACLK-AXR})$	Hold time, AXR input valid after ACLKR/X	ACLKR/X int	-1		ns
			ACLKR/X ext in ACLKR/X ext out	1.8		ns

(1) ACLKR internal: ACLKRCTL.CLKRM=1, PDIR.ACLKR = 1  
 ACLKR external input: ACLKRCTL.CLKRM=0, PDIR.ACLKR=0  
 ACLKR external output: ACLKRCTL.CLKRM=0, PDIR.ACLKR=1  
 ACLKX internal: ACLKXCTL.CLKXM=1, PDIR.ACLKX = 1  
 ACLKX external input: ACLKXCTL.CLKXM=0, PDIR.ACLKX=0  
 ACLKX external output: ACLKXCTL.CLKXM=0, PDIR.ACLKX=1

(2) P = AHCLKX period in ns.

(3) R = ACLKR/X period in ns.

**Table 5-67. Timing Requirements for McASP2<sup>(1)</sup>**

NO.	PARAMETER	DESCRIPTION	MODE	MIN	MAX	UNIT
1	$t_c(\text{AHCLKX})$	Cycle time, AHCLKX		20		ns
2	$t_w(\text{AHCLKX})$	Pulse duration, AHCLKX high or low		0.35P <sup>(2)</sup>		ns
3	$t_c(\text{ACLKX})$	Cycle time, ACLKX	Any Other Conditions	20		ns
			ACLKX/AFSX (In Sync Mode) and AXR are all inputs "80M" Virtual IO Timing Modes	12.5		ns
4	$t_w(\text{ACLKX})$	Pulse duration, ACLKX high or low	Any Other Conditions	0.5R - 3 <sup>(3)</sup>		ns
			ACLKX/AFSX (In Sync Mode) and AXR are all inputs "80M" Virtual IO Timing Modes	0.38R <sup>(3)</sup>		ns
5	$t_{su}(\text{AFSX-ACLK})$	Setup time, AFSX input valid before ACLKX	ACLKX int	20.3		ns
			ACLKX ext in ACLKX ext out	4.5		ns
			ACLKX ext in ACLKX ext out "80M" Virtual IO Timing Modes	3		ns

**Table 5-67. Timing Requirements for McASP2<sup>(1)</sup> (continued)**

NO.	PARAMETER	DESCRIPTION	MODE	MIN	MAX	UNIT
6	$t_{h(ACLK-AFSX)}$	Hold time, AFSX input valid after ACLKX	ACLKX int	-1		ns
			ACLKX ext in ACLKX ext out	1.8		ns
			ACLKX ext in ACLKX ext out "80M" Virtual IO Timing Modes	3		ns
7	$t_{su(AXR-ACLK)}$	Setup time, AXR input valid before ACLKX	ACLKX int	21.1		ns
			ACLKX ext in ACLKX ext out	4.5		ns
			ACLKX ext in ACLKX ext out "80M" Virtual IO Timing Modes	3		ns
8	$t_{h(ACLK-AXR)}$	Hold time, AXR input valid after ACLKX	ACLKX int	-1		ns
			ACLKX ext in ACLKX ext out	1.8		ns
			ACLKX ext in ACLKX ext out "80M" Virtual IO Timing Modes	3		ns

(1) ACLKX internal: ACLKXCTL.CLKXM=1, PDIR.ACLKX = 1

ACLKX external input: ACLKXCTL.CLKXM=0, PDIR.ACLKX=0

ACLKX external output: ACLKXCTL.CLKXM=0, PDIR.ACLKX=1

(2) P = AHCLKX period in ns.

(3) R = ACLKX period in ns.

**Table 5-68. Timing Requirements for McASP3/4/5/6/7/8<sup>(1)</sup>**

NO.	PARAMETER	DESCRIPTION	MODE	MIN	MAX	UNIT
1	$t_{c(AHCLKX)}$	Cycle time, AHCLKX		20		ns
2	$t_{w(AHCLKX)}$	Pulse duration, AHCLKX high or low		0.35P (2)		ns
3	$t_{c(ACLKR/X)}$	Cycle time, ACLKR/X		20		ns
4	$t_{w(ACLKR/X)}$	Pulse duration, ACLKR/X high or low		0.5R - 3 (3)		ns
5	$t_{su(AFSRX-ACLK)}$	Setup time, AFSRX input valid before ACLKR/X	ACLKR/X int	19.7		ns
			ACLKR/X ext in ACLKR/X ext out	5.6		ns
6	$t_{h(ACLK-AFSRX)}$	Hold time, AFSRX input valid after ACLKR/X	ACLKR/X int	-1.1		ns
			ACLKR/X ext in ACLKR/X ext out	2.5		ns
	$t_{su(AXR-ACLK)}$	Setup time, AXR input valid before ACLKX	ACLKX int (ASYNC=0)	20.3		ns
			ACLKR/X ext in ACLKR/X ext out	5.1		ns
8	$t_{h(ACLK-AXR)}$	Hold time, AXR input valid after ACLKX	ACLKX int (ASYNC=0)	-0.8		ns
			ACLKR/X ext in ACLKR/X ext out	2.5		ns

(1) ACLKR internal: ACLKRCTL.CLKRM=1, PDIR.ACLKR = 1 (NOT SUPPORTED)

ACLKR external input: ACLKRCTL.CLKRM=0, PDIR.ACLKR=0

ACLKR external output: ACLKRCTL.CLKRM=0, PDIR.ACLKR=1

ACLKX internal: ACLKXCTL.CLKXM=1, PDIR.ACLKX = 1

ACLKX external input: ACLKXCTL.CLKXM=0, PDIR.ACLKX=0

ACLKX external output: ACLKXCTL.CLKXM=0, PDIR.ACLKX=1

(2) P = AHCLKX period in ns.

(3) R = ACLKR/X period in ns.

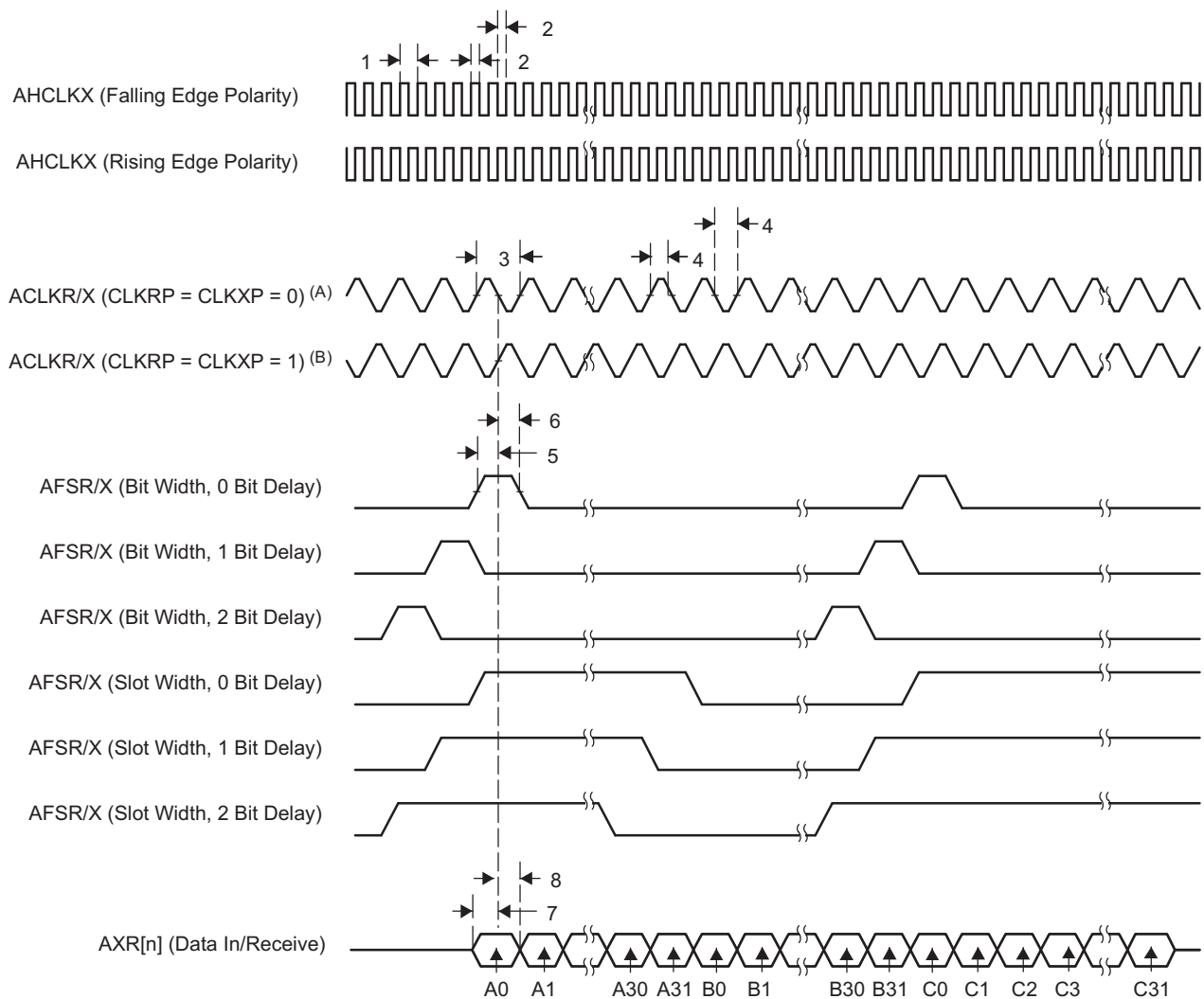

SPRS906\_TIMING\_McASP\_01

- A. For CLKRP = CLKXP = 0, the McASP transmitter is configured for rising edge (to shift data out) and the McASP receiver is configured for falling edge (to shift data in).
- B. For CLKRP = CLKXP = 1, the McASP transmitter is configured for falling edge (to shift data out) and the McASP receiver is configured for rising edge (to shift data in).

**Figure 5-50. McASP Input Timing**

**CAUTION**

The I/O Timings provided in this section are valid only for some McASP usage modes when the corresponding Virtual I/O Timings or Manual I/O Timings are configured as described in the tables found in this section.

Table 5-69, Table 5-70, Table 5-71 and Figure 5-51 present Switching Characteristics Over Recommended Operating Conditions for McASP1 to McASP8.

**Table 5-69. Switching Characteristics Over Recommended Operating Conditions for McASP1<sup>(1)</sup>**

NO.	PARAMETER	DESCRIPTION	MODE	MIN	MAX	UNIT
9	$t_{c(AHCLKX)}$	Cycle time, AHCLKX		20		ns
10	$t_{w(AHCLKX)}$	Pulse duration, AHCLKX high or low		0.5P - 2.5 <sup>(2)</sup>		ns
11	$t_{c(ACLKRX)}$	Cycle time, ACLKR/X		20		ns
12	$t_{w(ACLKRX)}$	Pulse duration, ACLKR/X high or low		0.5P - 2.5 <sup>(3)</sup>		ns
13	$t_{d(ACLK-AFSXR)}$	Delay time, ACLKR/X transmit edge to AFSX/R output valid	ACLKR/X int	-0.9	6	ns
			ACLKR/X ext in ACLKR/X ext out	2	23.1	ns
14	$t_{d(ACLK-AXR)}$	Delay time, ACLKR/X transmit edge to AXR output valid	ACLKR/X int	-1.4	6	ns
			ACLKR/X ext in ACLKR/X ext out	2	24.2	ns

- (1) ACLKR internal: ACLKRCTL.CLKRM=1, PDIR.ACLKR = 1  
 ACLKR external input: ACLKRCTL.CLKRM=0, PDIR.ACLKR=0  
 ACLKR external output: ACLKRCTL.CLKRM=0, PDIR.ACLKR=1  
 ACLKX internal: ACLKXCTL.CLKXM=1, PDIR.ACLKX = 1  
 ACLKX external input: ACLKXCTL.CLKXM=0, PDIR.ACLKX=0  
 ACLKX external output: ACLKXCTL.CLKXM=0, PDIR.ACLKX=1

(2) P = AHCLKX period in ns.

(3) R = ACLKR/X period in ns.

**Table 5-70. Switching Characteristics Over Recommended Operating Conditions for McASP2<sup>(1)</sup>**

NO.	PARAMETER	DESCRIPTION	MODE	MIN	MAX	UNIT
9	$t_{c(AHCLKX)}$	Cycle time, AHCLKX		20		ns
10	$t_{w(AHCLKX)}$	Pulse duration, AHCLKX high or low		0.5P - 2.5 <sup>(2)</sup>		ns
11	$t_{c(ACLKX)}$	Cycle time, ACLKX		20		ns
12	$t_{w(ACLKX)}$	Pulse duration, ACLKX high or low		0.5P - 2.5 <sup>(3)</sup>		ns
13	$t_{d(ACLK-AFSX)}$	Delay time, ACLKX transmit edge to AFSX output valid	ACLKX int	-1	6	ns
			ACLKX ext in ACLKX ext out	2	23.2	ns
14	$t_{d(ACLK-AXR)}$	Delay time, ACLKX transmit edge to AXR output valid	ACLKX int	-1.3	6	ns
			ACLKX ext in ACLKX ext out	2	23.7	ns

- (1) ACLKX internal: ACLKXCTL.CLKXM=1, PDIR.ACLKX = 1  
 ACLKX external input: ACLKXCTL.CLKXM=0, PDIR.ACLKX=0  
 ACLKX external output: ACLKXCTL.CLKXM=0, PDIR.ACLKX=1

(2) P = AHCLKX period in ns.

(3) R = ACLKX period in ns.

**Table 5-71. Switching Characteristics Over Recommended Operating Conditions for McASP3/4/5/6/7/8<sup>(1)</sup>**

NO.	PARAMETER	DESCRIPTION	MODE	MIN	MAX	UNIT
9	$t_{c(AHCLKX)}$	Cycle time, AHCLKX		20		ns
10	$t_{w(AHCLKX)}$	Pulse duration, AHCLKX high or low		0.5P - 2.5 <sup>(2)</sup>		ns
11	$t_{c(ACLKRX)}$	Cycle time, ACLKR/X		20		ns
12	$t_{w(ACLKRX)}$	Pulse duration, ACLKR/X high or low		0.5P - 2.5 <sup>(3)</sup>		ns



**Table 5-71. Switching Characteristics Over Recommended Operating Conditions for  
McASP3/4/5/6/7/8<sup>(1)</sup> (continued)**

NO.	PARAMETER	DESCRIPTION	MODE	MIN	MAX	UNIT
13	$t_{d(ACLK-AFSXR)}$	Delay time, ACLKR/X transmit edge to AFSX/R output valid	ACLKR/X int	-0.5	6	ns
			ACLKR/X ext in ACLKR/X ext out	1.9	24.5	ns
14	$t_{d(ACLK-AXR)}$	Delay time, ACLKR/X transmit edge to AXR output valid	ACLKR/X int	-1.4	7.1	ns
			ACLKR/X ext in ACLKR/X ext out	1.1	24.2	ns

(1) ACLKR internal: ACLKRCTL.CLKRM=1, PDIR.ACLKR = 1  
 ACLKR external input: ACLKRCTL.CLKRM=0, PDIR.ACLKR=0  
 ACLKR external output: ACLKRCTL.CLKRM=0, PDIR.ACLKR=1  
 ACLKX internal: ACLKXCTL.CLKXM=1, PDIR.ACLKX = 1  
 ACLKX external input: ACLKXCTL.CLKXM=0, PDIR.ACLKX=0  
 ACLKX external output: ACLKXCTL.CLKXM=0, PDIR.ACLKX=1

(2) P = AHCLKX period in ns.

(3) R = ACLKR/X period in ns.

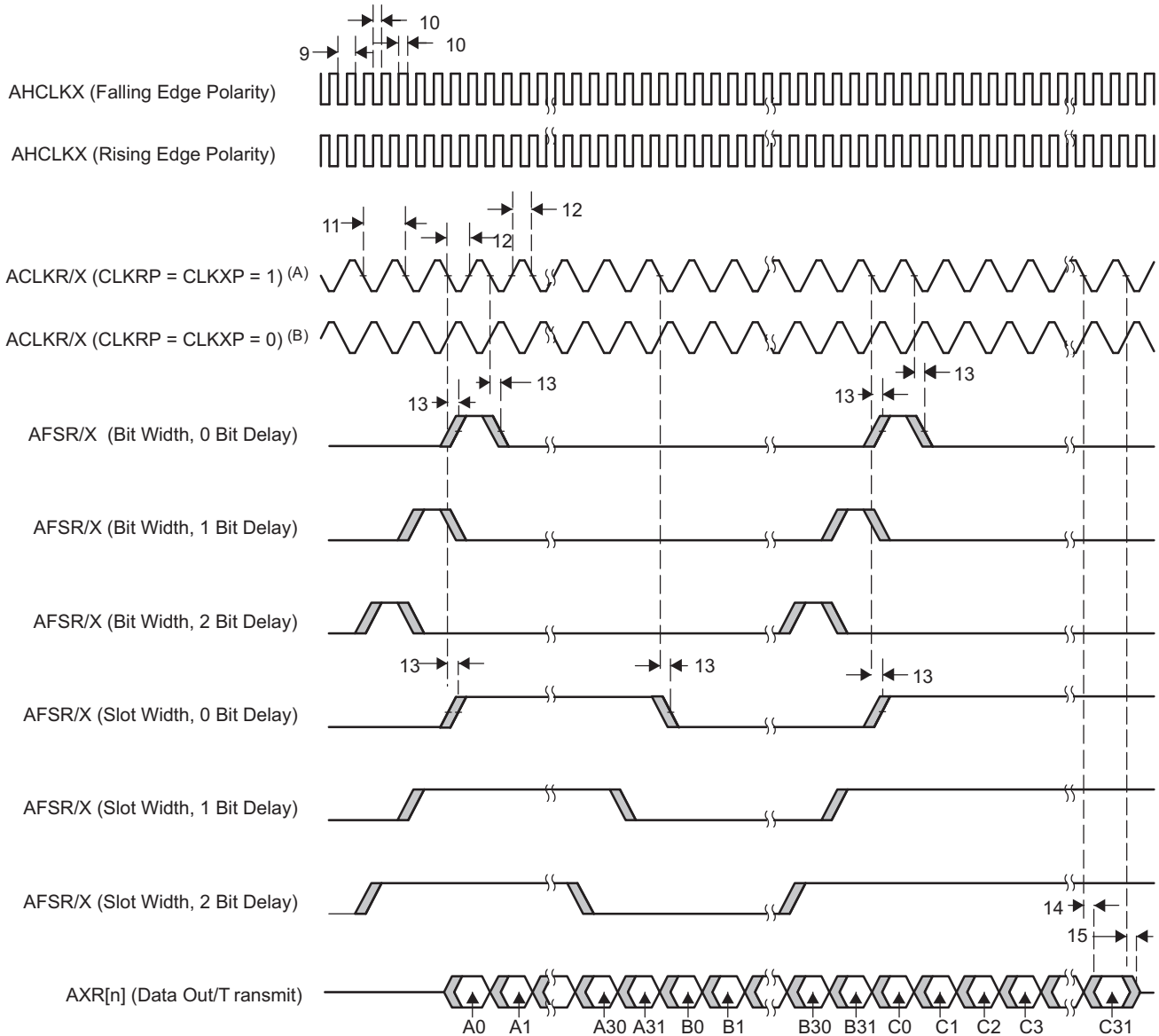

SPRS906\_TIMING\_McASP\_02

- A. For CLKRP = CLKXP = 1, the McASP transmitter is configured for falling edge (to shift data out) and the McASP receiver is configured for rising edge (to shift data in).
- B. For CLKRP = CLKXP = 0, the McASP transmitter is configured for rising edge (to shift data out) and the McASP receiver is configured for falling edge (to shift data in).

**Figure 5-51. McASP Output Timing**

**NOTE**

To configure the desired virtual mode the user must set MODESELECT bit and DELAYMODE bitfield for each corresponding pad control register.

The pad control registers are presented in [Table 4-27](#) and described in Device TRM, *Control Module Chapter*.

[Table 5-72](#) through [Table 5-79](#) explain all cases with Virtual Mode Details for McASP1/2/3/4/5/6/7/8 (see [Figure 5-52](#) through [Figure 5-59](#)).

**Table 5-72. Virtual Mode Case Details for McASP1**

No.	CASE	CASE Description	Virtual Mode Settings		Notes
			Signals	Virtual Mode Value	
<b>IP Mode : ASYNC</b>					
1	COIFOI	CLKX / FSX: Output CLKR / FSR: Input	AXR(Outputs)/CLKX/FSX	Default (No Virtual Mode)	See <a href="#">Figure 5-52</a>
			AXR(Inputs)/CLKR/FSR	MCASP1_VIRTUAL2_ASYNC_RX	
2	COIFIO	CLKX / FSR: Output CLKR / FSX: Input	AXR(Outputs)/CLKX/FSX	Default (No Virtual Mode)	See <a href="#">Figure 5-53</a>
			AXR(Inputs)/CLKR/FSR	MCASP1_VIRTUAL2_ASYNC_RX	
3	CIOFIO	CLKR / FSR: Output CLKX / FSX: Input	AXR(Outputs)/CLKX/FSX	MCASP1_VIRTUAL2_ASYNC_RX	See <a href="#">Figure 5-54</a>
			AXR(Inputs)/CLKR/FSR	Default (No Virtual Mode)	
4	CIOFOI	CLKR / FSX: Output CLKX / FSR: Input	AXR(Outputs)/CLKX/FSX	MCASP1_VIRTUAL2_ASYNC_RX	See <a href="#">Figure 5-55</a>
			AXR(Inputs)/CLKR/FSR	Default (No Virtual Mode)	
<b>IP Mode : SYNC (CLKR / FSR internally generated from CLKX / FSX)</b>					
5	CO-FO-	CLKX / FSX: Output	AXR(Outputs)/CLKX/FSX	Default (No Virtual Mode)	See <a href="#">Figure 5-56</a>
			AXR(Inputs)/CLKX/FSX	Default (No Virtual Mode)	
6	CI-FO-	FSX: Output CLKX: Input	AXR(Outputs)/CLKX/FSX	MCASP1_VIRTUAL1_SYNC_RX	See <a href="#">Figure 5-57</a>
			AXR(Inputs)/CLKX/FSX	MCASP1_VIRTUAL1_SYNC_RX	
7	CI-FI-	CLKX / FSX: Input	AXR(Outputs)/CLKX/FSX	MCASP1_VIRTUAL1_SYNC_RX	See <a href="#">Figure 5-58</a>
			AXR(Inputs)/CLKX/FSX	MCASP1_VIRTUAL1_SYNC_RX	
8	CO-FI-	CLKX: Output FSX: Input	AXR(Outputs)/CLKX/FSX	Default (No Virtual Mode)	See <a href="#">Figure 5-59</a>
			AXR(Inputs)/CLKX/FSX	Default (No Virtual Mode)	

**Table 5-73. Virtual Mode Case Details for McASP2**

No.	CASE	CASE Description	Virtual Mode Settings		Notes
			Signals	Virtual Mode Value	
<b>IP Mode : SYNC (CLKR / FSR internally generated from CLKX / FSX)</b>					
5	CO-FO-	CLKX / FSX: Output	AXR(Outputs)/CLKX/FSX	Default (No Virtual Mode)	See <a href="#">Figure 5-56</a>
			AXR(Inputs)/CLKX/FSX	Default (No Virtual Mode)	
6	CI-FO-	FSX: Output CLKX: Input	AXR(Outputs)/CLKX/FSX	MCASP2_VIRTUAL3_SYNC_RX	See <a href="#">Figure 5-57</a>
			AXR(Inputs)/CLKX/FSX	MCASP2_VIRTUAL3_SYNC_RX	
7	CI-FI-	CLKX / FSX: Input	AXR(Outputs)/CLKX/FSX	MCASP2_VIRTUAL3_SYNC_RX <sup>(1)</sup>	See <a href="#">Figure 5-58</a>
			AXR(Inputs)/CLKX/FSX	MCASP2_VIRTUAL3_SYNC_RX <sup>(1)</sup>	
			AXR(Inputs)/CLKX/FSX	MCASP2_VIRTUAL1_SYNC_RX_80M <sup>(2)</sup>	
8	CO-FI-	CLKX: Output FSX: Input	AXR(Outputs)/CLKX/FSX	Default (No Virtual Mode)	See <a href="#">Figure 5-59</a>
			AXR(Inputs)/CLKX/FSX	Default (No Virtual Mode)	

(1) Used up to 50MHz. Should also be used in a CI-FI- mixed case where AXR operate as both inputs and outputs (that is, AXR are bidirectional).

(2) Used in 80MHz input only mode when AXR, CLKX and FSX are all inputs.

**Table 5-74. Virtual Mode Case Details for McASP3**

No.	CASE	CASE Description	Virtual Mode Settings		Notes
			Signals	Virtual Mode Value	
<b>IP Mode : ASYNC</b>					
1	COIFOI	CLKX / FSX: Output CLKR / FSR: Input	AXR(Outputs)/CLKX/FSX	Default (No Virtual Mode)	See <a href="#">Figure 5-52</a>
			AXR(Inputs)/CLKR/FSR	MCASP3_VIRTUAL2_SYNC_RX	

**Table 5-74. Virtual Mode Case Details for McASP3 (continued)**

No.	CASE	CASE Description	Virtual Mode Settings		Notes
			Signals	Virtual Mode Value	
2	COIFIO	CLKX / FSR: Output CLKR / FSX: Input	AXR(Outputs)/CLKX/FSX	Default (No Virtual Mode)	See <a href="#">Figure 5-53</a>
			AXR(Inputs)/CLKR/FSR	MCASP3_VIRTUAL2_SYNC_RX	
3	CIOFIO	CLKR / FSR: Output CLKX / FSX: Input	AXR(Outputs)/CLKX/FSX	MCASP3_VIRTUAL2_SYNC_RX	See <a href="#">Figure 5-54</a>
			AXR(Inputs)/CLKR/FSR	MCASP3_VIRTUAL2_SYNC_RX	
4	CIOFOI	CLKR / FSX: Output CLKX / FSR: Input	AXR(Outputs)/CLKX/FSX	MCASP3_VIRTUAL2_SYNC_RX	See <a href="#">Figure 5-55</a>
			AXR(Inputs)/CLKR/FSR	MCASP3_VIRTUAL2_SYNC_RX	
<b>IP Mode : SYNC (CLKR / FSR internally generated from CLKX / FSX)</b>					
5	CO-FO-	CLKX / FSX: Output	AXR(Outputs)/CLKX/FSX	Default (No Virtual Mode)	See <a href="#">Figure 5-56</a>
			AXR(Inputs)/CLKX/FSX	Default (No Virtual Mode)	
6	CI-FO-	FSX: Output CLKX: Input	AXR(Outputs)/CLKX/FSX	MCASP3_VIRTUAL2_SYNC_RX	See <a href="#">Figure 5-57</a>
			AXR(Inputs)/CLKX/FSX	MCASP3_VIRTUAL2_SYNC_RX	
7	CI-FI-	CLKX / FSX: Input	AXR(Outputs)/CLKX/FSX	MCASP3_VIRTUAL2_SYNC_RX	See <a href="#">Figure 5-58</a>
			AXR(Inputs)/CLKX/FSX	MCASP3_VIRTUAL2_SYNC_RX	
8	CO-FI-	CLKX: Output FSX: Input	AXR(Outputs)/CLKX/FSX	Default (No Virtual Mode)	See <a href="#">Figure 5-59</a>
			AXR(Inputs)/CLKX/FSX	Default (No Virtual Mode)	

**Table 5-75. Virtual Mode Case Details for McASP4**

No.	CASE	CASE Description	Virtual Mode Settings		Notes
			Signals	Virtual Mode Value	
<b>IP Mode : ASYNC</b>					
1	COIFOI	CLKX / FSX: Output CLKR / FSR: Input	AXR(Outputs)/CLKX/FSX	Default (No Virtual Mode)	See <a href="#">Figure 5-52</a>
			AXR(Inputs)/CLKR/FSR	MCASP4_VIRTUAL1_SYNC_RX	
2	COIFIO	CLKX / FSR: Output CLKR / FSX: Input	AXR(Outputs)/CLKX/FSX	Default (No Virtual Mode)	See <a href="#">Figure 5-53</a>
			AXR(Inputs)/CLKR/FSR	MCASP4_VIRTUAL1_SYNC_RX	
3	CIOFIO	CLKR / FSR: Output CLKX / FSX: Input	AXR(Outputs)/CLKX/FSX	MCASP4_VIRTUAL1_SYNC_RX	See <a href="#">Figure 5-54</a>
			AXR(Inputs)/CLKR/FSR	MCASP4_VIRTUAL1_SYNC_RX	
4	CIOFOI	CLKR / FSX: Output CLKX / FSR: Input	AXR(Outputs)/CLKX/FSX	MCASP4_VIRTUAL1_SYNC_RX	See <a href="#">Figure 5-55</a>
			AXR(Inputs)/CLKR/FSR	MCASP4_VIRTUAL1_SYNC_RX	
<b>IP Mode : SYNC (CLKR / FSR internally generated from CLKX / FSX)</b>					
5	CO-FO-	CLKX / FSX: Output	AXR(Outputs)/CLKX/FSX	Default (No Virtual Mode)	See <a href="#">Figure 5-56</a>
			AXR(Inputs)/CLKX/FSX	Default (No Virtual Mode)	
6	CI-FO-	FSX: Output CLKX: Input	AXR(Outputs)/CLKX/FSX	MCASP4_VIRTUAL1_SYNC_RX	See <a href="#">Figure 5-57</a>
			AXR(Inputs)/CLKX/FSX	MCASP4_VIRTUAL1_SYNC_RX	
7	CI-FI-	CLKX / FSX: Input	AXR(Outputs)/CLKX/FSX	MCASP4_VIRTUAL1_SYNC_RX	See <a href="#">Figure 5-58</a>
			AXR(Inputs)/CLKX/FSX	MCASP4_VIRTUAL1_SYNC_RX	
8	CO-FI-	CLKX: Output FSX: Input	AXR(Outputs)/CLKX/FSX	Default (No Virtual Mode)	See <a href="#">Figure 5-59</a>
			AXR(Inputs)/CLKX/FSX	Default (No Virtual Mode)	

**Table 5-76. Virtual Mode Case Details for McASP5**

No.	CASE	CASE Description	Virtual Mode Settings		Notes
			Signals	Virtual Mode Value	
<b>IP Mode : ASYNC</b>					
1	COIFOI	CLKX / FSX: Output CLKR / FSR: Input	AXR(Outputs)/CLKX/FSX	Default (No Virtual Mode)	See <a href="#">Figure 5-52</a>
			AXR(Inputs)/CLKR/FSR	MCASP5_VIRTUAL1_SYNC_RX	
2	COIFIO	CLKX / FSR: Output CLKR / FSX: Input	AXR(Outputs)/CLKX/FSX	Default (No Virtual Mode)	See <a href="#">Figure 5-53</a>
			AXR(Inputs)/CLKR/FSR	MCASP5_VIRTUAL1_SYNC_RX	
3	CIOFIO	CLKR / FSR: Output CLKX / FSX: Input	AXR(Outputs)/CLKX/FSX	MCASP5_VIRTUAL1_SYNC_RX	See <a href="#">Figure 5-54</a>
			AXR(Inputs)/CLKR/FSR	MCASP5_VIRTUAL1_SYNC_RX	
4	CIOFOI	CLKR / FSX: Output CLKX / FSR: Input	AXR(Outputs)/CLKX/FSX	MCASP5_VIRTUAL1_SYNC_RX	See <a href="#">Figure 5-55</a>
			AXR(Inputs)/CLKR/FSR	MCASP5_VIRTUAL1_SYNC_RX	
<b>IP Mode : SYNC (CLKR / FSR internally generated from CLKX / FSX)</b>					
5	CO-FO-	CLKX / FSX: Output	AXR(Outputs)/CLKX/FSX	Default (No Virtual Mode)	See <a href="#">Figure 5-56</a>
			AXR(Inputs)/CLKX/FSX	Default (No Virtual Mode)	
6	CI-FO-	FSX: Output CLKX: Input	AXR(Outputs)/CLKX/FSX	MCASP5_VIRTUAL1_SYNC_RX	See <a href="#">Figure 5-57</a>
			AXR(Inputs)/CLKX/FSX	MCASP5_VIRTUAL1_SYNC_RX	
7	CI-FI-	CLKX / FSX: Input	AXR(Outputs)/CLKX/FSX	MCASP5_VIRTUAL1_SYNC_RX	See <a href="#">Figure 5-58</a>
			AXR(Inputs)/CLKX/FSX	MCASP5_VIRTUAL1_SYNC_RX	
8	CO-FI-	CLKX: Output FSX: Input	AXR(Outputs)/CLKX/FSX	Default (No Virtual Mode)	See <a href="#">Figure 5-59</a>
			AXR(Inputs)/CLKX/FSX	Default (No Virtual Mode)	

**Table 5-77. Virtual Mode Case Details for McASP6**

No.	CASE	CASE Description	Virtual Mode Settings		Notes
			Signals	Virtual Mode Value	
<b>IP Mode : ASYNC</b>					
1	COIFOI	CLKX / FSX: Output CLKR / FSR: Input	AXR(Outputs)/CLKX/FSX	Default (No Virtual Mode)	See <a href="#">Figure 5-52</a>
			AXR(Inputs)/CLKR/FSR	MCASP6_VIRTUAL1_SYNC_RX	
2	COIFIO	CLKX / FSR: Output CLKR / FSX: Input	AXR(Outputs)/CLKX/FSX	Default (No Virtual Mode)	See <a href="#">Figure 5-53</a>
			AXR(Inputs)/CLKR/FSR	MCASP6_VIRTUAL1_SYNC_RX	
3	CIOFIO	CLKR / FSR: Output CLKX / FSX: Input	AXR(Outputs)/CLKX/FSX	MCASP6_VIRTUAL1_SYNC_RX	See <a href="#">Figure 5-54</a>
			AXR(Inputs)/CLKR/FSR	MCASP6_VIRTUAL1_SYNC_RX	
4	CIOFOI	CLKR / FSX: Output CLKX / FSR: Input	AXR(Outputs)/CLKX/FSX	MCASP6_VIRTUAL1_SYNC_RX	See <a href="#">Figure 5-55</a>
			AXR(Inputs)/CLKR/FSR	MCASP6_VIRTUAL1_SYNC_RX	
<b>IP Mode : SYNC (CLKR / FSR internally generated from CLKX / FSX)</b>					
5	CO-FO-	CLKX / FSX: Output	AXR(Outputs)/CLKX/FSX	Default (No Virtual Mode)	See <a href="#">Figure 5-56</a>
			AXR(Inputs)/CLKX/FSX	Default (No Virtual Mode)	
6	CI-FO-	FSX: Output CLKX: Input	AXR(Outputs)/CLKX/FSX	MCASP6_VIRTUAL1_SYNC_RX	See <a href="#">Figure 5-57</a>
			AXR(Inputs)/CLKX/FSX	MCASP6_VIRTUAL1_SYNC_RX	
7	CI-FI-	CLKX / FSX: Input	AXR(Outputs)/CLKX/FSX	MCASP6_VIRTUAL1_SYNC_RX	See <a href="#">Figure 5-58</a>
			AXR(Inputs)/CLKX/FSX	MCASP6_VIRTUAL1_SYNC_RX	
8	CO-FI-	CLKX: Output FSX: Input	AXR(Outputs)/CLKX/FSX	Default (No Virtual Mode)	See <a href="#">Figure 5-59</a>
			AXR(Inputs)/CLKX/FSX	Default (No Virtual Mode)	

**Table 5-78. Virtual Mode Case Details for McASP7**

No.	CASE	CASE Description	Virtual Mode Settings		Notes
			Signals	Virtual Mode Value	
<b>IP Mode : ASYNC</b>					
1	COIFOI	CLKX / FSX: Output CLKR / FSR: Input	AXR(Outputs)/CLKX/FSX	Default (No Virtual Mode)	See <a href="#">Figure 5-52</a>
			AXR(Inputs)/CLKR/FSR	MCASP7_VIRTUAL2_SYNC_RX	
2	COIFIO	CLKX / FSR: Output CLKR / FSX: Input	AXR(Outputs)/CLKX/FSX	Default (No Virtual Mode)	See <a href="#">Figure 5-53</a>
			AXR(Inputs)/CLKR/FSR	MCASP7_VIRTUAL2_SYNC_RX	
3	CIOFIO	CLKR / FSR: Output CLKX / FSX: Input	AXR(Outputs)/CLKX/FSX	MCASP7_VIRTUAL2_SYNC_RX	See <a href="#">Figure 5-54</a>
			AXR(Inputs)/CLKR/FSR	MCASP7_VIRTUAL2_SYNC_RX	
4	CIOFOI	CLKR / FSX: Output CLKX / FSR: Input	AXR(Outputs)/CLKX/FSX	MCASP7_VIRTUAL2_SYNC_RX	See <a href="#">Figure 5-55</a>
			AXR(Inputs)/CLKR/FSR	MCASP7_VIRTUAL2_SYNC_RX	
<b>IP Mode : SYNC (CLKR / FSR internally generated from CLKX / FSX)</b>					
5	CO-FO-	CLKX / FSX: Output	AXR(Outputs)/CLKX/FSX	Default (No Virtual Mode)	See <a href="#">Figure 5-56</a>
			AXR(Inputs)/CLKX/FSX	Default (No Virtual Mode)	
6	CI-FO-	FSX: Output CLKX: Input	AXR(Outputs)/CLKX/FSX	MCASP7_VIRTUAL2_SYNC_RX	See <a href="#">Figure 5-57</a>
			AXR(Inputs)/CLKX/FSX	MCASP7_VIRTUAL2_SYNC_RX	
7	CI-FI-	CLKX / FSX: Input	AXR(Outputs)/CLKX/FSX	MCASP7_VIRTUAL2_SYNC_RX	See <a href="#">Figure 5-58</a>
			AXR(Inputs)/CLKX/FSX	MCASP7_VIRTUAL2_SYNC_RX	
8	CO-FI-	CLKX: Output FSX: Input	AXR(Outputs)/CLKX/FSX	Default (No Virtual Mode)	See <a href="#">Figure 5-59</a>
			AXR(Inputs)/CLKX/FSX	Default (No Virtual Mode)	

**Table 5-79. Virtual Mode Case Details for McASP8**

No.	CASE	CASE Description	Virtual Mode Settings		Notes
			Signals	Virtual Mode Value	
<b>IP Mode : ASYNC</b>					
1	COIFOI	CLKX / FSX: Output CLKR / FSR: Input	AXR(Outputs)/CLKX/FSX	Default (No Virtual Mode)	See <a href="#">Figure 5-52</a>
			AXR(Inputs)/CLKR/FSR	MCASP8_VIRTUAL1_SYNC_RX	
2	COIFIO	CLKX / FSR: Output CLKR / FSX: Input	AXR(Outputs)/CLKX/FSX	Default (No Virtual Mode)	See <a href="#">Figure 5-53</a>
			AXR(Inputs)/CLKR/FSR	MCASP8_VIRTUAL1_SYNC_RX	
3	CIOFIO	CLKR / FSR: Output CLKX / FSX: Input	AXR(Outputs)/CLKX/FSX	MCASP8_VIRTUAL1_SYNC_RX	See <a href="#">Figure 5-54</a>
			AXR(Inputs)/CLKR/FSR	MCASP8_VIRTUAL1_SYNC_RX	
4	CIOFOI	CLKR / FSX: Output CLKX / FSR: Input	AXR(Outputs)/CLKX/FSX	MCASP8_VIRTUAL1_SYNC_RX	See <a href="#">Figure 5-55</a>
			AXR(Inputs)/CLKR/FSR	MCASP8_VIRTUAL1_SYNC_RX	
<b>IP Mode : SYNC (CLKR / FSR internally generated from CLKX / FSX)</b>					
5	CO-FO-	CLKX / FSX: Output	AXR(Outputs)/CLKX/FSX	Default (No Virtual Mode)	See <a href="#">Figure 5-56</a>
			AXR(Inputs)/CLKX/FSX	Default (No Virtual Mode)	
6	CI-FO-	FSX: Output CLKX: Input	AXR(Outputs)/CLKX/FSX	MCASP8_VIRTUAL1_SYNC_RX	See <a href="#">Figure 5-57</a>
			AXR(Inputs)/CLKX/FSX	MCASP8_VIRTUAL1_SYNC_RX	
7	CI-FI-	CLKX / FSX: Input	AXR(Outputs)/CLKX/FSX	MCASP8_VIRTUAL1_SYNC_RX	See <a href="#">Figure 5-58</a>
			AXR(Inputs)/CLKX/FSX	MCASP8_VIRTUAL1_SYNC_RX	
8	CO-FI-	CLKX: Output FSX: Input	AXR(Outputs)/CLKX/FSX	Default (No Virtual Mode)	See <a href="#">Figure 5-59</a>
			AXR(Inputs)/CLKX/FSX	Default (No Virtual Mode)	

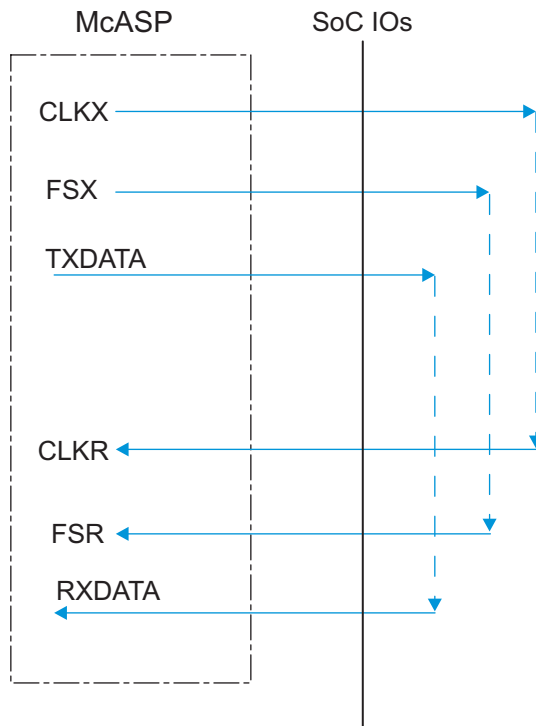

SPRS906\_MCASP\_uc\_01

Figure 5-52. McASP1-8 COIFOI – ASYNC Mode

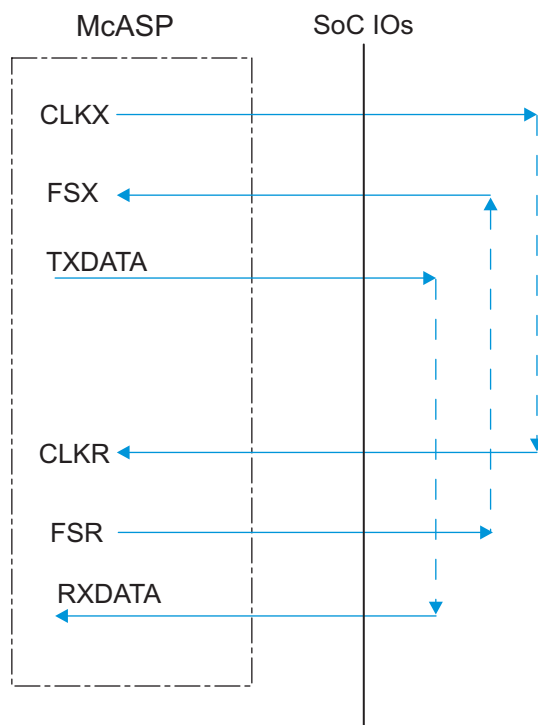

SPRS906\_MCASP\_uc\_02

Figure 5-53. McASP1-8 COIFIO – ASYNC Mode

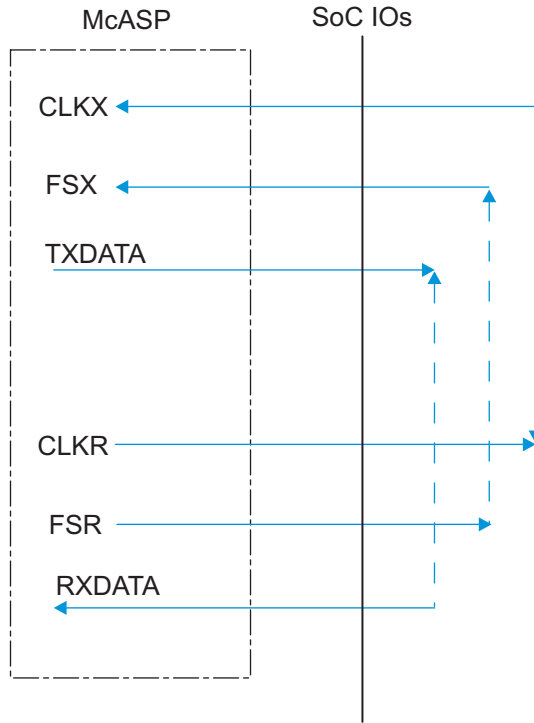

SPRS906\_MCASP\_uc\_03

Figure 5-54. McASP1-8 CIOFIO – ASYNC Mode

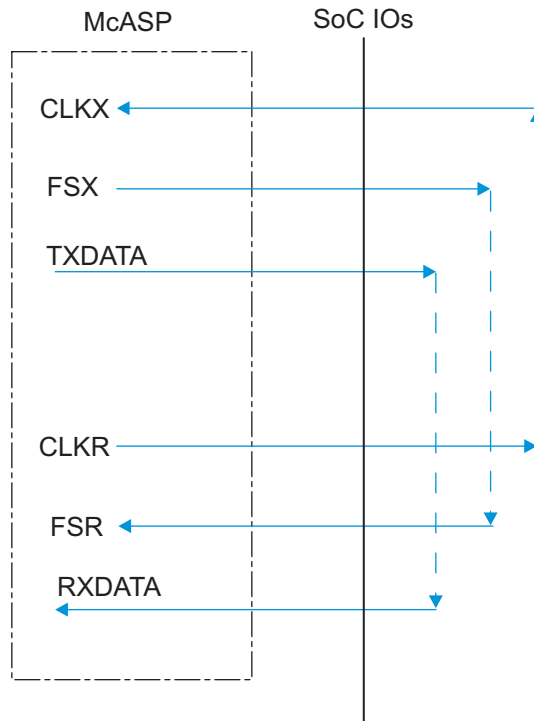

SPRS906\_MCASP\_uc\_04

Figure 5-55. McASP1-8 CIOFOI – ASYNC Mode



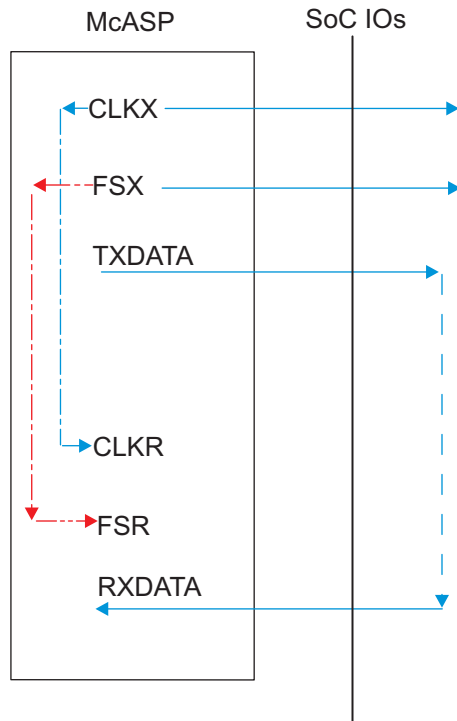

SPRS906\_MCASP\_uc\_05

Figure 5-56. McASP1-8 CO-FO- – SYNC Mode

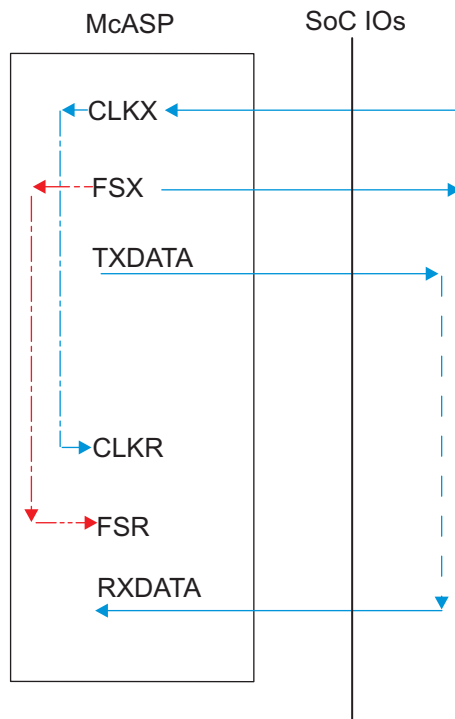

SPRS906\_MCASP\_uc\_06

Figure 5-57. McASP1-8 CI-FO- – SYNC Mode

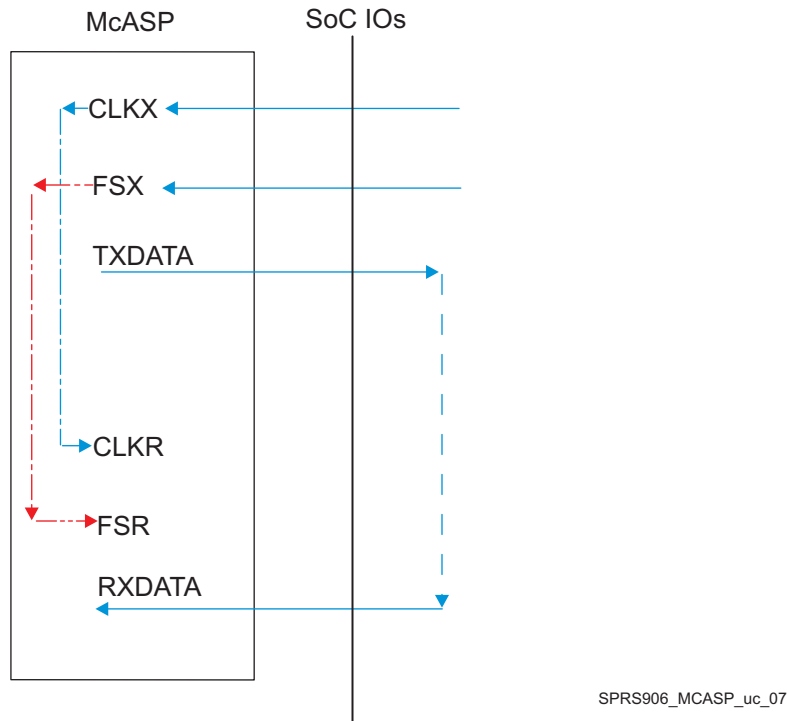

Figure 5-58. McASP1-8 CI-FI – SYNC Mode

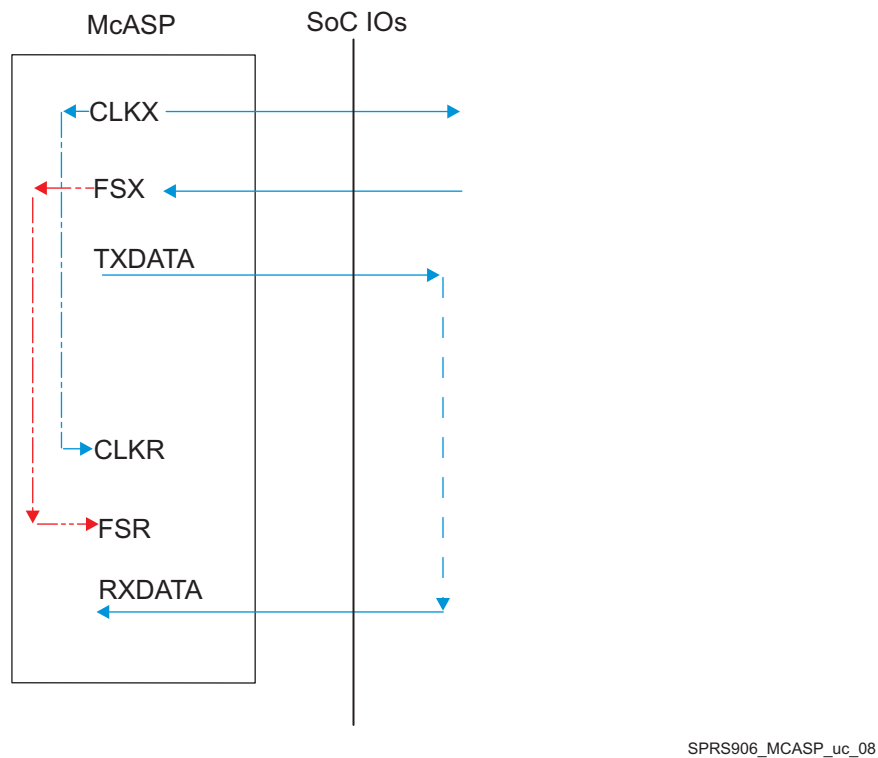

Figure 5-59. McASP1-8 CO-FI – SYNC Mode

Virtual IO Timings Modes must be used to ensure some IO timings for McASP1. See [Table 5-28 Modes Summary](#) for a list of IO timings requiring the use of Virtual IO Timings Modes. See [Table 5-80 Virtual Functions Mapping for McASP1](#) for a definition of the Virtual modes.

[Table 5-80](#) presents the values for DELAYMODE bitfield.

**Table 5-80. Virtual Functions Mapping for McASP1**

BALL	BALL NAME	Delay Mode Value		MUXMODE		
		MCASP1_VIRTUAL1_SYNC_RX	MCASP1_VIRTUAL2_ASYNC_RX	0	1	2
C16	mcasp1_aclkx	15	14	mcasp1_aclkx		
H21	gpio6_14	14	13		mcasp1_axr8	
E17	mcasp1_axr13	15	14	mcasp1_axr13		
A15	mcasp1_axr4	14	13	mcasp1_axr4		
H24	xref_clk2	14	13			mcasp1_axr6
B17	mcasp1_axr9	15	14	mcasp1_axr9		
A16	mcasp1_axr7	14	13	mcasp1_axr7		
A19	mcasp1_axr12	15	14	mcasp1_axr12		
K23	gpio6_16	14	13		mcasp1_axr10	
K22	gpio6_15	14	13		mcasp1_axr9	
H25	xref_clk3	14	13			mcasp1_axr7
A17	mcasp1_axr6	14	13	mcasp1_axr6		
B16	mcasp1_axr10	15	14	mcasp1_axr10		
D17	mcasp1_fsr	N/A	14	mcasp1_fsr		
A18	mcasp1_axr8	15	14	mcasp1_axr8		
B18	mcasp1_axr11	15	14	mcasp1_axr11		
C14	mcasp1_axr2	14	13	mcasp1_axr2		
C17	mcasp1_fsx	15	14	mcasp1_fsx		
E16	mcasp1_axr14	15	14	mcasp1_axr14		
F16	mcasp1_axr15	15	14	mcasp1_axr15		
B14	mcasp1_axr1	15	14	mcasp1_axr1		
D16	mcasp1_aclkr	N/A	14	mcasp1_aclkr		
A14	mcasp1_axr5	14	13	mcasp1_axr5		
J24	xref_clk1	15	14			mcasp1_axr5
D14	mcasp1_axr0	15	14	mcasp1_axr0		
B15	mcasp1_axr3	14	13	mcasp1_axr3		
J25	xref_clk0	15	14			mcasp1_axr4

Virtual IO Timings Modes must be used to ensure some IO timings for McASP2. See [Table 5-28 Modes Summary](#) for a list of IO timings requiring the use of Virtual IO Timings Modes. See [Table 5-81 Virtual Functions Mapping for McASP2](#) for a definition of the Virtual modes.

[Table 5-81](#) presents the values for DELAYMODE bitfield.

**Table 5-81. Virtual Functions Mapping for McASP2**

BALL	BALL NAME	Delay Mode Value				MUXMODE		
		MCASP2_VIRTUAL1_SYNC_RX_80M	MCASP2_VIRTUAL2_ASYNC_RX	MCASP2_VIRTUAL3_SYNC_RX	MCASP2_VIRTUAL4_ASYNC_RX_80M	0	1	2
B22	mcasp3_axr0	15	14	10	9			mcasp2_axr14
D20	mcasp2_axr6	14	13	12	11	mcasp2_axr6		
C19	mcasp2_axr5	14	13	12	11	mcasp2_axr5		
D19	mcasp2_fsx	15	14	10	9	mcasp2_fsx		
H24	xref_clk2	12	11	10	9		mcasp2_axr10	
B21	mcasp2_axr3	15	14	10	9	mcasp2_axr3		
A22	mcasp3_aclkx	15	14	10	9			mcasp2_axr12
E19	mcasp2_aclkx	15	14	10	9	mcasp2_aclkx		
C20	mcasp2_axr7	14	13	12	11	mcasp2_axr7		
H25	xref_clk3	12	11	10	9		mcasp2_axr11	
B23	mcasp3_axr1	15	14	10	8			mcasp2_axr15
A23	mcasp3_fsx	15	14	10	9			mcasp2_axr13
A21	mcasp2_axr2	15	14	10	9	mcasp2_axr2		
B20	mcasp2_axr4	14	13	12	11	mcasp2_axr4		
J24	xref_clk1	10	9	8	6		mcasp2_axr9	
B19	mcasp2_axr1	14	13	12	11	mcasp2_axr1		
A20	mcasp2_axr0	14	13	12	11	mcasp2_axr0		
J25	xref_clk0	10	9	8	6		mcasp2_axr8	

Virtual IO Timings Modes must be used to ensure some IO timings for McASP3/4/5/6/7/8. See [Table 5-28 Modes Summary](#) for a list of IO timings requiring the use of Virtual IO Timings Modes. See [Table 5-82 Virtual Functions Mapping for McASP3/4/5/6/7/8](#) for a definition of the Virtual modes.

[Table 5-82](#) presents the values for DELAYMODE bitfield.

**Table 5-82. Virtual Functions Mapping for McASP3/4/5/6/7/8**

BALL	BALL NAME	Delay Mode Value	MUXMODE		
			0	1	2
<b>MCASP3_VIRTUAL2_SYNC_RX</b>					
B21	mcasp2_axr3	8		mcasp3_axr3	
A22	mcasp3_aclkx	8	mcasp3_aclkx	mcasp3_aclkr	
B22	mcasp3_axr0	8	mcasp3_axr0		
B23	mcasp3_axr1	6	mcasp3_axr1		
A23	mcasp3_fsx	8	mcasp3_fsx	mcasp3_fsr	
A21	mcasp2_axr2	8		mcasp3_axr2	
<b>MCASP4_VIRTUAL1_SYNC_RX</b>					
B25	mcasp4_fsx	14	mcasp4_fsx	mcasp4_fsr	
C23	mcasp4_aclkx	14	mcasp4_aclkx	mcasp4_aclkr	
A24	mcasp4_axr0	14	mcasp4_axr0		
D23	mcasp4_axr1	14	mcasp4_axr1		
A14	mcasp1_axr5	12		mcasp4_axr3	
A15	mcasp1_axr4	12		mcasp4_axr2	
<b>MCASP5_VIRTUAL1_SYNC_RX</b>					
AC3	mcasp5_aclkx	14	mcasp5_aclkx	mcasp5_aclkr	
U6	mcasp5_fsx	14	mcasp5_fsx	mcasp5_fsr	
AC4	mcasp5_axr1	14	mcasp5_axr1		
A17	mcasp1_axr6	12		mcasp5_axr2	
AA5	mcasp5_axr0	14	mcasp5_axr0		
A16	mcasp1_axr7	12		mcasp5_axr3	
<b>MCASP6_VIRTUAL1_SYNC_RX</b>					
C14	mcasp1_axr2	12		mcasp6_axr2	
B15	mcasp1_axr3	12		mcasp6_axr3	
B16	mcasp1_axr10	10		mcasp6_aclkx	mcasp6_aclkr
B17	mcasp1_axr9	10		mcasp6_axr1	
A18	mcasp1_axr8	10		mcasp6_axr0	
B18	mcasp1_axr11	10		mcasp6_fsx	mcasp6_fsr
<b>MCASP7_VIRTUAL2_SYNC_RX</b>					
A19	mcasp1_axr12	10		mcasp7_axr0	
F16	mcasp1_axr15	10		mcasp7_fsx	mcasp7_fsr
E16	mcasp1_axr14	10		mcasp7_aclkx	mcasp7_aclkr

**Table 5-82. Virtual Functions Mapping for McASP3/4/5/6/7/8 (continued)**

BALL	BALL NAME	Delay Mode Value	MUXMODE		
			0	1	2
E17	mcasp1_axr13	10		mcasp7_axr1	
D16	mcasp1_aclkr	13		mcasp7_axr2	
D17	mcasp1_fsr	13		mcasp7_axr3	
<b>MCASP8_VIRTUAL1_SYNC_RX</b>					
B20	mcasp2_axr4	10		mcasp8_axr0	
C20	mcasp2_axr7	10		mcasp8_fsx	mcasp8_fsr
D20	mcasp2_axr6	10		mcasp8_aclkx	mcasp8_aclkr
C19	mcasp2_axr5	10		mcasp8_axr1	

### 5.10.6.15 USB

SuperSpeed USB DRD Subsystem has four instances in the device providing the following functions:

- USB1: SuperSpeed (SS) USB 3.0 Dual-Role-Device (DRD) subsystem with integrated SS (USB3.0) PHY and HS/FS (USB2.0) PHY.
- USB2: High-Speed (HS) USB 2.0 Dual-Role-Device (DRD) subsystem with integrated HS/FS PHY.
- USB3: HS USB 2.0 Dual-Role-Device (DRD) subsystem with ULPI (SDR) interface to external HS/FS PHYs.

#### NOTE

For more information, see the SuperSpeed USB DRD section of the Device TRM.

#### 5.10.6.15.1 USB1 DRD PHY

The USB1 DRD interface supports the following applications:

- USB2.0 High-Speed PHY port (1.8 V and 3.3 V): this asynchronous high-speed interface is compliant with the USB2.0 PHY standard with an internal transceiver (USB2.0 standard v2.0), for a maximum data rate of 480 Mbps.
- USB3.0 Super-Speed PHY port (1.8 V): this asynchronous differential super-speed interface is compliant with the USB3.0 RX/TX PHY standard (USB3.0 standard v1.0) for a maximum data bit rate of 5Gbps.

#### 5.10.6.15.2 USB2 PHY

The USB2 interface supports the following applications:

- USB2.0 High-Speed PHY port (1.8 V and 3.3 V): this asynchronous high-speed interface is compliant with the USB2.0 PHY standard with an internal transceiver (USB2.0 standard v2.0), for a maximum data rate of 480 Mbps.

### 5.10.6.16 USB3 DRD ULPI—SDR—Slave Mode—12-pin Mode

The USB3 DRD interfaces support the following application:

- USB ULPI port: this synchronous interface is compliant with the USB2.0 ULPI SDR standard (UTMI+ v1.22), for alternative off-chip USB2.0 PHY interface; that is, with external transceiver with a maximum frequency of 60 MHz (synchronous slave mode, SDR, 12-pin, 8-data-bit).

#### NOTE

The Universal Serial Bus k ULPI modules are also referred as USBk where k = 3, 4.

Table 5-83, Table 5-84 and Figure 5-60 assume testing over the recommended operating conditions and electrical characteristic conditions.

**Table 5-83. Timing Requirements for ULPI SDR Slave Mode**

NO.	PARAMETER	DESCRIPTION	MIN	MAX	UNIT
US1	$t_{c(\text{clk})}$	Cycle time, usb_ulpi_clk period	16.66		ns
US5	$t_{su(\text{ctrlV-clkH})}$	Setup time, usb_ulpi_dir/usb_ulpi_next valid before usb_ulpi_clk rising edge	6.73		ns
US6	$t_{h(\text{clkH-ctrlV})}$	Hold time, usb_ulpi_dir/usb_ulpi_next valid after usb_ulpi_clk rising edge	-0.41		ns
US7	$t_{su(\text{dV-clkH})}$	Setup time, usb_ulpi_d[7:0] valid before usb_ulpi_clk rising edge	6.73		ns
US8	$t_{h(\text{clkH-dV})}$	Hold time, usb_ulpi_d[7:0] valid after usb_ulpi_clk rising edge	-0.41		ns

**Table 5-84. Switching Characteristics for ULPI SDR Slave Mode**

NO.	PARAMETER	DESCRIPTION	MIN	MAX	UNIT
US4	$t_{d(\text{clkH-stpV})}$	Delay time, usb_ulpi_clk rising edge high to output usb_ulpi_stp valid	0.44	8.35	ns
US9	$t_{d(\text{clkL-dov})}$	Delay time, usb_ulpi_clk rising edge high to output usb_ulpi_d[7:0] valid	0.44	8.35	ns

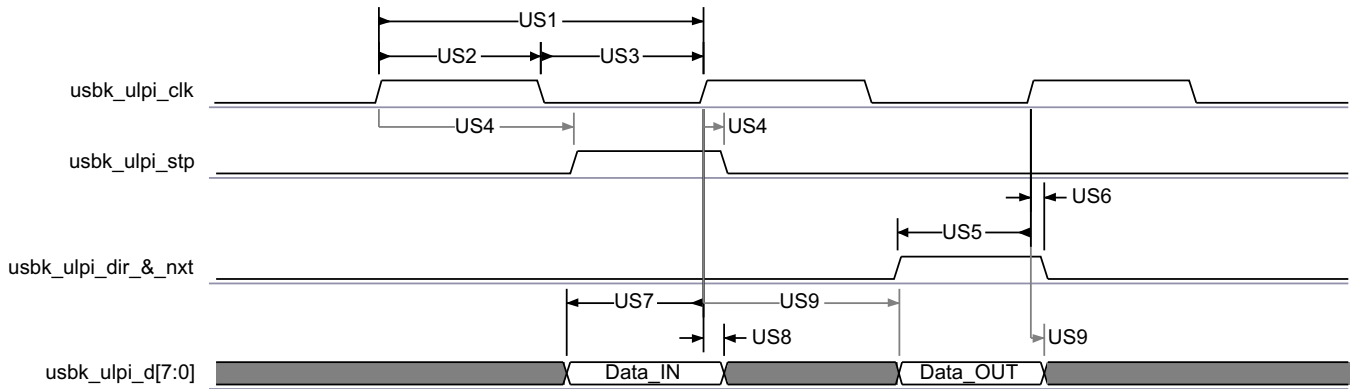

SPRS969\_TIMING\_USB\_01

**Figure 5-60. HS USB3 ULPI —SDR—Slave Mode—12-pin Mode**

In [Table 5-85](#) are presented the specific groupings of signals (IOSET) for use with USB3 signals.

**Table 5-85. USB3 IOSETs**

SIGNALS	IOSET2		IOSET3	
	BALL	MUX	BALL	MUX
usb3_ulpi_d7	Y5	3	N4	6
usb3_ulpi_d6	Y6	3	N3	6
usb3_ulpi_d5	Y2	3	P1	6
usb3_ulpi_d4	Y1	3	N1	6
usb3_ulpi_d3	Y4	3	P2	6
usb3_ulpi_d2	AA2	3	N2	6
usb3_ulpi_d1	AA3	3	R1	6
usb3_ulpi_d0	W2	3	R2	6
usb3_ulpi_nxt	Y3	3	P3	6
usb3_ulpi_dir	AA1	3	P4	6
usb3_ulpi_stp	AA4	3	T5	6
usb3_ulpi_clk	AB1	3	T4	6

**5.10.6.17 PCIe3**

The device supports connections to PCIe-compliant devices via the integrated PCIe master/slave bus interface. The PCIe module is comprised of a dual-mode PCIe core and a SerDes PHY. Each PCIe subsystem controller has support for PCIe Gen-II mode (5.0 Gbps /lane) and Gen-I mode (2.5 Gbps/lane) (Single Lane and Flexible dual lane configuration).

The device PCIe supports the following features:

- 16-bit operation @250 MHz on PIPE interface (per 16-bit lane)
- Supports 2 ports x 1 lane or 1 port x 2 lanes configuration
- Single virtual channel (VC0), single traffic class (TC0)
- Single function in end-point mode



- Automatic width and speed negotiation
- Max payload: 128 byte outbound, 256 byte inbound
- Automatic credit management
- ECRC generation and checking
- Configurable BAR filtering
- Legacy interrupt reception (RC) and generation (EP)
- MSI generation and reception
- PCI Express Active State Power Management (ASPM) state L0s and L1 (with exceptions)
- All PCI Device Power Management D-states with the exception of D3<sub>cold</sub> / L2 state

The PCIe controller on this device conforms to the PCI Express Base 3.0 Specification, revision 1.0 and the PCI Local Bus Specification, revision 3.0.

---

**NOTE**

For more information, see the PCIe Controller section of the Device TRM.

---

#### 5.10.6.18 DCAN

The device provides two DCAN interfaces for supporting distributed realtime control with a high level of security. The DCAN interfaces implement the following features:

- Supports CAN protocol version 2.0 part A, B
- Bit rates up to 1 MBit/s
- 64 message objects
- Individual identifier mask for each message object
- Programmable FIFO mode for message objects
- Programmable loop-back modes for self-test operation
- Suspend mode for debug support
- Software module reset
- Automatic bus on after Bus-Off state by a programmable 32-bit timer
- Direct access to Message RAM during test mode
- CAN Rx/Tx pins are configurable as general-purpose IO pins
- Two interrupt lines (plus additional parity-error interrupts line)
- RAM initialization
- DMA support

---

**NOTE**

For more information, see the DCAN section of the Device TRM.

---



---

**NOTE**

The Controller Area Network Interface x (x = 1 to 2) is also referred to as DCANx.

---



---

**NOTE**

Refer to the CAN Specification for calculations necessary to validate timing compliance. Jitter tolerance calculations must be performed to validate the implementation.

---

[Table 5-86](#) and [Table 5-87](#) present timing and switching characteristics for DCANx Interface.

**Table 5-86. Timing Requirements for DCANx Receive**

NO.	PARAMETER	DESCRIPTION	MIN	NOM	MAX	UNIT
-	$f_{(\text{baud})}$	Maximum programmable baud rate			1	Mbps
-	$t_{d(\text{DCANRX})}$	Delay time, DCANx_RX pin to receive shift register			15	ns

**Table 5-87. Switching Characteristics Over Recommended Operating Conditions for DCANx Transmit**

NO.	PARAMETER	DESCRIPTION	MIN	MAX	UNIT
-	$f_{(\text{baud})}$	Maximum programmable baud rate		1	Mbps
-	$t_{d(\text{DCANTX})}$	Delay time, Transmit shift register to DCANx_TX pin <sup>(1)</sup>		23	ns

(1) These values do not include rise/fall times of the output buffer.

### 5.10.6.19 GMAC\_SW

The three-port gigabit ethernet switch subsystem (GMAC\_SW) provides ethernet packet communication and can be configured as an ethernet switch. It provides the Gigabit Media Independent Interface (G/MII) in MII mode, Reduced Gigabit Media Independent Interface (RGMII), Reduced Media Independent Interface (RMII), and the Management Data Input/Output (MDIO) for physical layer device (PHY) management.

#### NOTE

For more information, see the Ethernet Subsystem section of the Device TRM.

#### NOTE

The Gigabit, Reduced and Media Independent Interface n (n = 0 to 1) are also referred to as MII<sub>n</sub>, RMII<sub>n</sub> and RGMII<sub>n</sub>.

#### CAUTION

The I/O Timings provided in this section are valid only if signals within a single IOSET are used. The IOSETs are defined in [Table 5-92](#), [Table 5-95](#), [Table 5-100](#) and [Table 5-107](#).

#### CAUTION

The I/O Timings provided in this section are valid only for some GMAC usage modes when the corresponding Virtual I/O Timings or Manual I/O Timings are configured as described in the tables found in this section.

#### 5.10.6.19.1 GMAC MII Timings

[Table 5-88](#) and [Figure 5-61](#) present timing requirements for MII<sub>n</sub> in receive operation.

**Table 5-88. Timing Requirements for miin\_rxclk - MII Operation**

NO.	PARAMETER	DESCRIPTION	SPEED	MIN	MAX	UNIT
1	$t_{c(\text{RX\_CLK})}$	Cycle time, miin_rxclk	10 Mbps	400		ns
			100 Mbps	40		ns
2	$t_{w(\text{RX\_CLKH})}$	Pulse duration, miin_rxclk high	10 Mbps	140	260	ns
			100 Mbps	14	26	ns
3	$t_{w(\text{RX\_CLKL})}$	Pulse duration, miin_rxclk low	10 Mbps	140	260	ns
			100 Mbps	14	26	ns

**Table 5-88. Timing Requirements for miin\_rxclk - MII Operation (continued)**

NO.	PARAMETER	DESCRIPTION	SPEED	MIN	MAX	UNIT
4	$t_t(\text{RX\_CLK})$	Transition time, miin_rxclk	10 Mbps		3	ns
			100 Mbps		3	ns

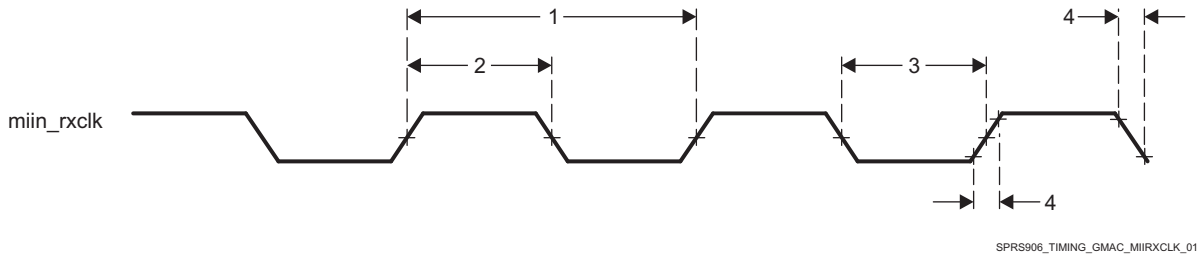
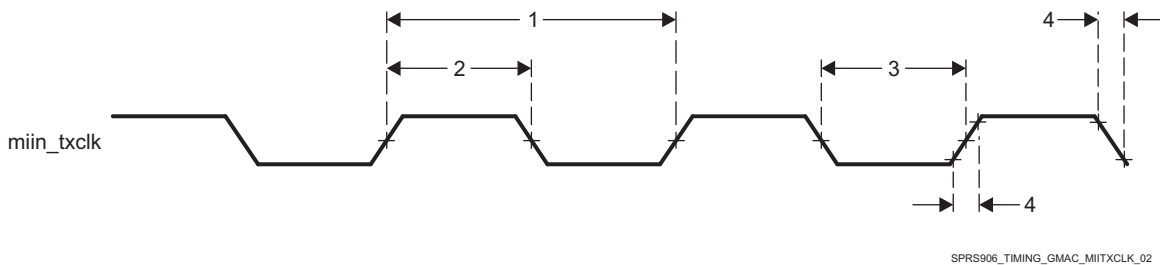

**Figure 5-61. Clock Timing (GMAC Receive) - MII in operation**

Table 5-89 and Figure 5-62 present timing requirements for MII in transmit operation.

**Table 5-89. Timing Requirements for miin\_txclk - MII Operation**

NO.	PARAMETER	DESCRIPTION	SPEED	MIN	MAX	UNIT
1	$t_c(\text{TX\_CLK})$	Cycle time, miin_txclk	10 Mbps	400		ns
			100 Mbps	40		ns
2	$t_w(\text{TX\_CLKH})$	Pulse duration, miin_txclk high	10 Mbps	140	260	ns
			100 Mbps	14	26	ns
3	$t_w(\text{TX\_CLKL})$	Pulse duration, miin_txclk low	10 Mbps	140	260	ns
			100 Mbps	14	26	ns
4	$t_t(\text{TX\_CLK})$	Transition time, miin_txclk	10 Mbps		3	ns
			100 Mbps		3	ns

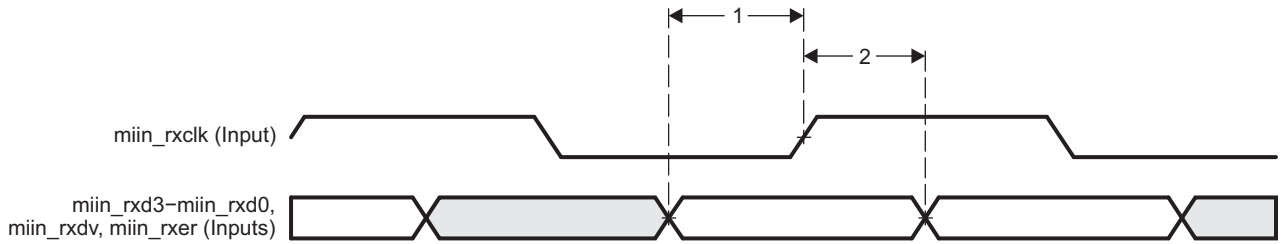

**Figure 5-62. Clock Timing (GMAC Transmit) - MII in operation**

Table 5-90 and Figure 5-63 present timing requirements for GMAC MII in Receive 10/100Mbit/s.

**Table 5-90. Timing Requirements for GMAC MII in Receive 10/100 Mbit/s**

NO.	PARAMETER	DESCRIPTION	MIN	MAX	UNIT
1	$t_{su}(\text{RXD-RX\_CLK})$	Setup time, receive selected signals valid before miin_rxclk	8		ns
	$t_{su}(\text{RX\_DV-RX\_CLK})$				
	$t_{su}(\text{RX\_ER-RX\_CLK})$				
2	$t_h(\text{RX\_CLK-RXD})$	Hold time, receive selected signals valid after miin_rxclk	8		ns
	$t_h(\text{RX\_CLK-RX\_DV})$				
	$t_h(\text{RX\_CLK-RX\_ER})$				



SPRS906\_TIMING\_GMAC\_MIIrcv\_03

**Figure 5-63. GMAC Receive Interface Timing MII operation**

Table 5-91 and Figure 5-64 present timing requirements for GMAC MII Transmit 10/100Mbit/s.

**Table 5-91. Switching Characteristics Over Recommended Operating Conditions for GMAC MII Transmit 10/100 Mbits/s**

NO.	PARAMETER	DESCRIPTION	MIN	MAX	UNIT
1	$t_d(TX\_CLK-TXD)$	Delay time, miin_txclk to transmit selected signals valid	0	25	ns
	$t_d(TX\_CLK-TX\_EN)$				
	$t_d(TX\_CLK-TX\_ER)$				

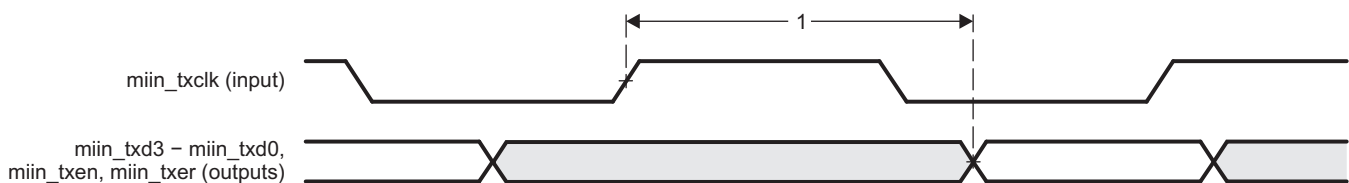

SPRS906\_TIMING\_GMAC\_MIItx\_04

**Figure 5-64. GMAC Transmit Interface Timing MII operation**

In Table 5-92 are presented the specific groupings of signals (IOSET) for use with GMAC MII signals.

**Table 5-92. GMAC MII IOSETs**

SIGNALS	IOSET5		IOSET6	
	BALL	MUX	BALL	MUX
<b>GMAC MII1</b>				
mii1_txd3	E11	8		
mii1_txd2	A13	8		
mii1_txd1	A12	8		
mii1_txd0	B12	8		
mii1_rxd3	B10	8		
mii1_rxd2	A10	8		
mii1_rxd1	F10	8		
mii1_rxd0	E10	8		
mii1_col	E13	8		
mii1_rxer	B13	8		
mii1_txer	F11	8		
mii1_txen	D13	8		
mii1_crs	C13	8		
mii1_rxclk	B11	8		
mii1_txclk	C11	8		
mii1_rxdv	D11	8		

**Table 5-92. GMAC MII IOSETs (continued)**

SIGNALS	IOSET5		IOSET6	
	BALL	MUX	BALL	MUX
<b>GMAC MII0</b>				
mii0_txd3			P2	3
mii0_txd2			N1	3
mii0_txd1			N3	3
mii0_txd0			N4	3
mii0_rxd3			T4	3
mii0_rxd2			T5	3
mii0_rxd1			R2	3
mii0_rxd0			R1	3
mii0_txclk			N2	3
mii0_txer			L6	3
mii0_rxer			P3	3
mii0_rxdv			N5	3
mii0_crs			P4	3
mii0_col			L5	3
mii0_rxclk			N6	3
mii0_txen			P1	3

**5.10.6.19.2 GMAC MDIO Interface Timings**

**CAUTION**

The I/O Timings provided in this section are valid only for some GMAC usage modes when the corresponding Virtual I/O Timings or Manual I/O Timings are configured as described in the tables found in this section.

Table 5-93, Table 5-93 and Figure 5-65 present timing requirements for MDIO.

**Table 5-93. Timing Requirements for MDIO Input**

No	PARAMETER	DESCRIPTION	MIN	MAX	UNIT
MDIO1	$t_{c(MDC)}$	Cycle time, MDC	400		ns
MDIO2	$t_{w(MDCH)}$	Pulse Duration, MDC High	160		ns
MDIO3	$t_{w(MDCL)}$	Pulse Duration, MDC Low	160		ns
MDIO4	$t_{su(MDIO-MDC)}$	Setup time, MDIO valid before MDC High	90		ns
MDIO5	$t_{h(MDIO\_MDC)}$	Hold time, MDIO valid from MDC High	0		ns

**Table 5-94. Switching Characteristics Over Recommended Operating Conditions for MDIO Output**

NO	PARAMETER	DESCRIPTION	MIN	MAX	UNIT
MDIO6	$t_{t(MDC)}$	Transition time, MDC		5	ns
MDIO7	$t_{d(MDC-MDIO)}$	Delay time, MDC low to MDIO valid	-150	150	ns

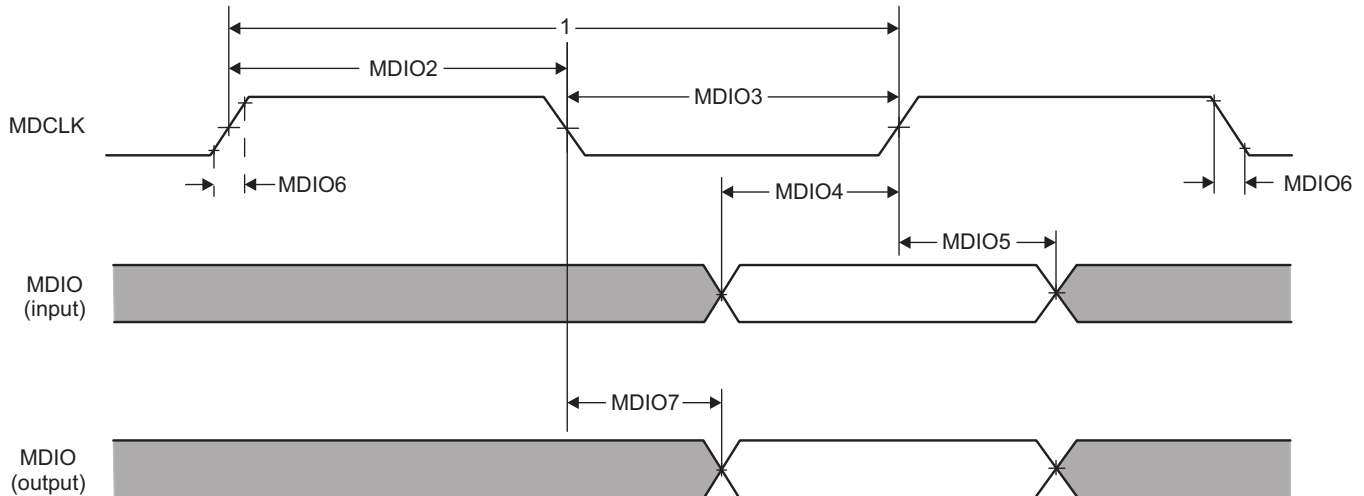

**Figure 5-65. GMAC MDIO diagrams**

In [Table 5-95](#) are presented the specific groupings of signals (IOSET) for use with GMAC MDIO signals.

**Table 5-95. GMAC MDIO IOSETS**

SIGNALS	IOSET7		IOSET8		IOSET9		IOSET10	
	BALL	MUX	BALL	MUX	BALL	MUX	BALL	MUX
mdio_d	C10	3	L6	0	Y6	1	E25	5
mdio_mclk	D10	3	L5	0	Y5	1	E24	5

### 5.10.6.19.3 GMAC RMII Timings

The main reference clock REF\_CLK (RMII\_50MHZ\_CLK) of RMII interface is internally supplied from PRCM. The source of this clock could be either externally sourced from the RMII\_MHZ\_50\_CLK pin of the device or internally generated from DPLL\_GMAC output clock GMAC\_RMII\_HS\_CLK. Please see the PRCM chapter of the device TRM for full details about RMII reference clock.

#### CAUTION

The I/O Timings provided in this section are valid only for some GMAC usage modes when the corresponding Virtual I/O Timings or Manual I/O Timings are configured as described in the tables found in this section.

[Table 5-96](#), [Table 5-97](#) and [Figure 5-66](#) present timing requirements for GMAC RMII Receive.

**Table 5-96. Timing Requirements for GMAC REF\_CLK - RMII Operation**

NO.	PARAMETER	DESCRIPTION	MIN	MAX	UNIT
RMII1	$t_{c(REF\_CLK)}$	Cycle time, REF_CLK	20		ns
RMII2	$t_{w(REF\_CLKH)}$	Pulse duration, REF_CLK high	7	13	ns
RMII3	$t_{w(REF\_CLKL)}$	Pulse duration, REF_CLK low	7	13	ns
RMII4	$t_{tt(REF\_CLK)}$	Transistion time, REF_CLK		3	ns

**Table 5-97. Timing Requirements for GMAC RMIIIn Receive**

NO.	PARAMETER	DESCRIPTION	MIN	MAX	UNIT
RMII5	$t_{su}(RXD-REF\_CLK)$	Setup time, receive selected signals valid before REF_CLK	4		ns
	$t_{su}(CRS\_DV-REF\_CLK)$				
	$t_{su}(RX\_ER-REF\_CLK)$				
RMII6	$t_h(REF\_CLK-RXD)$	Hold time, receive selected signals valid after REF_CLK	2		ns
	$t_h(REF\_CLK-CRS\_DV)$				
	$t_h(REF\_CLK-RX\_ER)$				

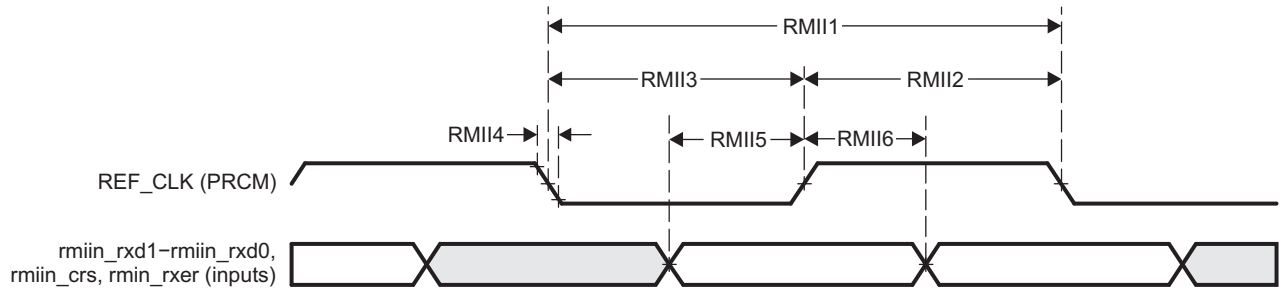

SPRS906\_TIMING\_GMAC\_RMII\_TX\_09

**Figure 5-66. GMAC Receive Interface Timing RMIIIn operation**

Table 5-98, Table 5-98 and Figure 5-67 present switching characteristics for GMAC RMIIIn Transmit 10/100Mbit/s.

**Table 5-98. Switching Characteristics Over Recommended Operating Conditions for GMAC REF\_CLK - RMII Operation**

NO.	PARAMETER	DESCRIPTION	MIN	MAX	UNIT
RMII7	$t_c(REF\_CLK)$	Cycle time, REF_CLK	20		ns
RMII8	$t_w(REF\_CLKH)$	Pulse duration, REF_CLK high	7	13	ns
RMII9	$t_w(REF\_CLKL)$	Pulse duration, REF_CLK low	7	13	ns
RMII10	$t_t(REF\_CLK)$	Transistion time, REF_CLK		3	ns

**Table 5-99. Switching Characteristics Over Recommended Operating Conditions for GMAC RMIIIn Transmit 10/100 Mbits/s**

NO.	PARAMETER	DESCRIPTION	RMIIIn	MIN	MAX	UNIT
RMII11	$t_d(REF\_CLK-TXD)$	Delay time, REF_CLK high to selected transmit signals valid	RMII0	2	13.5	ns
	$t_d(REF\_CLK-TXEN)$					
	$t_d(REF\_CLK-TXD)$		RMII1	2	13.8	ns
	$t_d(REF\_CLK-TXEN)$					

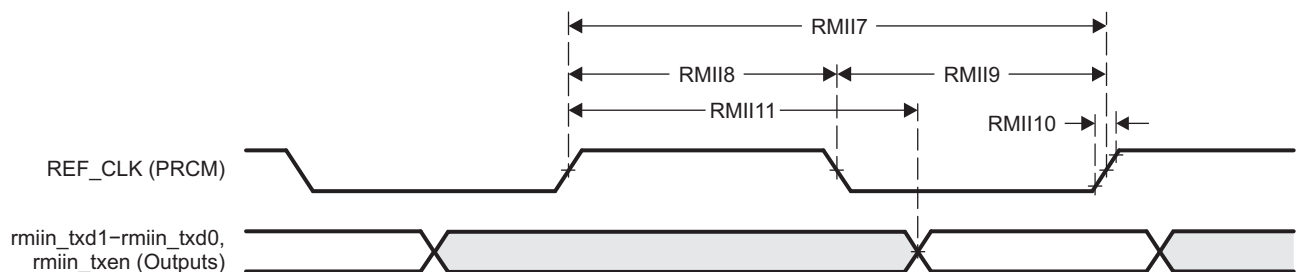

SPRS906\_TIMING\_GMAC\_RMII\_TX\_07

**Figure 5-67. GMAC Transmit Interface Timing RMIIIn Operation**

In [Table 5-100](#) are presented the specific groupings of signals (IOSET) for use with GMAC RMII signals.

**Table 5-100. GMAC RMII IOSETs**

SIGNALS	IOSET1		IOSET2	
	BALL	MUX	BALL	MUX
<b>GMAC RMII1</b>				
RMII_MHZ_50_CLK	P5	0		
rmii1_txd1	P2	2		
rmii1_txd0	N1	2		
rmii1_rxd1	T4	2		
rmii1_rxd0	T5	2		
rmii1_rxer	N6	2		
rmii1_txen	N2	2		
rmii1_crs	N5	2		
<b>GMAC RMII0</b>				
RMII_MHZ_50_CLK			P5	0
rmii0_txd1			N3	1
rmii0_txd0			N4	1
rmii0_rxd1			R2	1
rmii0_rxd0			R1	1
rmii0_txen			P1	1
rmii0_rxer			P3	1
rmii0_crs			P4	1

Manual IO Timings Modes must be used to ensure some IO timings for GMAC. See [Table 5-28 Modes Summary](#) for a list of IO timings requiring the use of Manual IO Timings Modes. See [Table 5-101 Manual Functions Mapping for GMAC RMII0](#) for a definition of the Manual modes.

[Table 5-101](#) lists the A\_DELAY and G\_DELAY values needed to calculate the correct values to be set in the CFG\_x registers.

**Table 5-101. Manual Functions Mapping for GMAC RMII0**

BALL	BALL NAME	GMAC_RMII0_MANUAL1		CFG REGISTER	MUXMODE	
		A_DELAY (ps)	G_DELAY (ps)		0	1
P5	RMII_MHZ_50_CLK	0	0	CFG_RMII_MHZ_50_CLK_IN	RMII_MHZ_50_CLK	
R1	rgmii0_txd0	2444	804	CFG_RGMII0_TXD0_IN		rmii0_rxd0
R2	rgmii0_txd1	2453	981	CFG_RGMII0_TXD1_IN		rmii0_rxd1
P3	rgmii0_txd2	2356	847	CFG_RGMII0_TXD2_IN		rmii0_rxer
P4	rgmii0_txd3	2415	993	CFG_RGMII0_TXD3_IN		rmii0_crs

Manual IO Timings Modes must be used to ensure some IO timings for GMAC. See [Table 5-28 Modes Summary](#) for a list of IO timings requiring the use of Manual IO Timings Modes. See [Table 5-102 Manual Functions Mapping for GMAC RMII1](#) for a definition of the Manual modes.

[Table 5-102](#) list the A\_DELAY and G\_DELAY values needed to calculate the correct values to be set in the CFG\_x registers.



**Table 5-102. Manual Functions Mapping for GMAC RMII1**

BALL	BALL NAME	GMAC_RMII1_MANUAL1		CFG REGISTER	MUXMODE	
		A_DELAY (ps)	G_DELAY (ps)		0	2
P5	RMII_MHZ_50_CLK	0	0	CFG_RMII_MHZ_50_CLK_IN	RMII_MHZ_50_CLK	
T5	rgmii0_txctl	2450	909	CFG_RGMII0_TXCTL_IN		rmii1_rxd0
T4	rgmii0_txc	2327	926	CFG_RGMII0_TXC_IN		rmii1_rxd1
N6	uart3_txd	2553	443	CFG_UART3_TXD_IN		rmii1_rxer
N5	uart3_rxd	1943	1110	CFG_UART3_RXD_IN		rmii1_crs

**5.10.6.19.4 GMAC RGMII Timings**

**CAUTION**

The I/O Timings provided in this section are valid only for some GMAC usage modes when the corresponding Virtual I/O Timings or Manual I/O Timings are configured as described in the tables found in this section.

Table 5-103, Table 5-104 and Figure 5-68 present timing requirements for receive RGMII operation.

**Table 5-103. Timing Requirements for rgmiin\_rxc - RGMII Operation**

NO.	PARAMETER	DESCRIPTION	SPEED	MIN	MAX	UNIT
1	$t_{c(RXC)}$	Cycle time, rgmiin_rxc	10 Mbps	360	440	ns
			100 Mbps	36	44	ns
			1000 Mbps	7.2	8.8	ns
2	$t_{w(RXCH)}$	Pulse duration, rgmiin_rxc high	10 Mbps	160	240	ns
			100 Mbps	16	24	ns
			1000 Mbps	3.6	4.4	ns
3	$t_{w(RXCL)}$	Pulse duration, rgmiin_rxc low	10 Mbps	160	240	ns
			100 Mbps	16	24	ns
			1000 Mbps	3.6	4.4	ns
4	$t_{t(RXC)}$	Transition time, rgmiin_rxc	10 Mbps		0.75	ns
			100 Mbps		0.75	ns
			1000 Mbps		0.75	ns

**Table 5-104. Timing Requirements for GMAC RGMII Input Receive for 10/100/1000 Mbps <sup>(1)</sup>**

NO.	PARAMETER	DESCRIPTION	MODE	MIN	MAX	UNIT
5	$t_{su(RXD-RXCH)}$	Setup time, receive selected signals valid before rgmiin_rxc high/low	RGMII0/1	1		ns
6	$t_{h(RXCH-RXD)}$	Hold time, receive selected signals valid after rgmiin_rxc high/low	RGMII0/1	1		ns

(1) For RGMII, receive selected signals include: rgmiin\_rxd[3:0] and rgmiin\_rxctl.

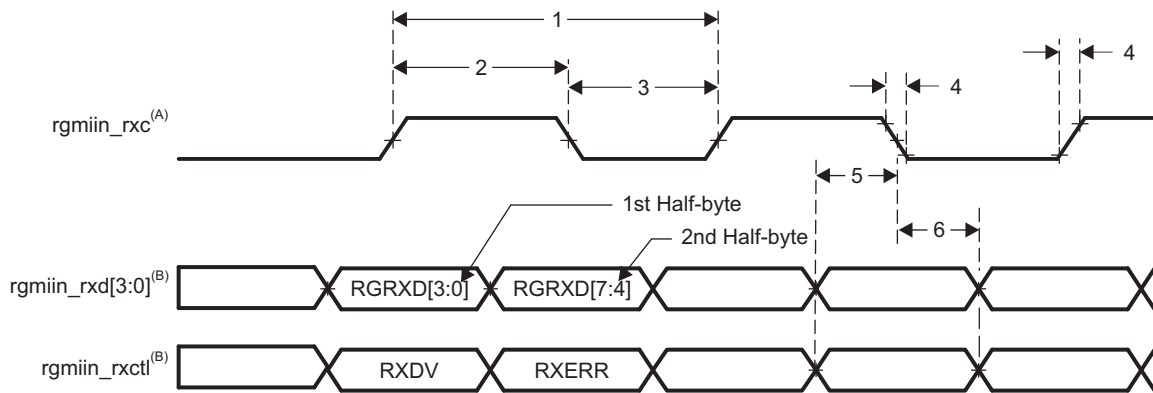

SPRS906\_TIMING\_GMAC\_RGMII\_RX\_08

- A. rgmiin\_rxc must be externally delayed relative to the data and control pins.
- B. Data and control information is received using both edges of the clocks. rgmiin\_rxd[3:0] carries data bits 3-0 on the rising edge of rgmiin\_rxc and data bits 7-4 on the falling edge of rgmiin\_rxc. Similarly, rgmiin\_rxctl carries RXDV on rising edge of rgmiin\_rxc and RXERR on falling edge of rgmiin\_rxc.

**Figure 5-68. GMAC Receive Interface Timing, RGMII operation**

Table 5-105, Table 5-106 and Figure 5-69 present switching characteristics for transmit - RGMII for 10/100/1000Mbit/s.

**Table 5-105. Switching Characteristics Over Recommended Operating Conditions for rgmiin\_txctl - RGMII Operation for 10/100/1000 Mbit/s**

NO.	PARAMETER	DESCRIPTION	SPEED	MIN	MAX	UNIT
1	$t_{c(TXC)}$	Cycle time, rgmiin_txc	10 Mbps	360	440	ns
			100 Mbps	36	44	ns
			1000 Mbps	7.2	8.8	ns
2	$t_w(TXCH)$	Pulse duration, rgmiin_txc high	10 Mbps	160	240	ns
			100 Mbps	16	24	ns
			1000 Mbps	3.6	4.4	ns
3	$t_w(TXCL)$	Pulse duration, rgmiin_txc low	10 Mbps	160	240	ns
			100 Mbps	16	24	ns
			1000 Mbps	3.6	4.4	ns
4	$t_t(TXC)$	Transition time, rgmiin_txc	10 Mbps		0.75	ns
			100 Mbps		0.75	ns
			1000 Mbps		0.75	ns

**Table 5-106. Switching Characteristics for GMAC RGMII Output Transmit for 10/100/1000 Mbps (1)**

NO.	PARAMETER	DESCRIPTION	MODE	MIN	MAX	UNIT
5	$t_{osu(TXD-TXC)}$	Output Setup time, transmit selected signals valid to rgmiin_txc high/low	RGMII0, Internal Delay Enabled, 1000 Mbps	1.05 <sup>(2)</sup>		ns
			RGMII0, Internal Delay Enabled, 10/100 Mbps	1.2		ns
			RGMII1, Internal Delay Enabled, 1000 Mbps	1.05 <sup>(3)</sup>		ns
			RGMII1, Internal Delay Enabled, 10/100 Mbps	1.2		ns

**Table 5-106. Switching Characteristics for GMAC RGMII Output Transmit for 10/100/1000 Mbps (1) (continued)**

NO.	PARAMETER	DESCRIPTION	MODE	MIN	MAX	UNIT
6	t <sub>oh</sub> (TXC-TXD)	Output Hold time, transmit selected signals valid after rgmiiin_txc high/low	RGMII0, Internal Delay Enabled, 1000 Mbps	1.05 (2)		ns
			RGMII0, Internal Delay Enabled, 10/100 Mbps	1.2		ns
			RGMII1, Internal Delay Enabled, 1000 Mbps	1.05 (3)		ns
			RGMII1, Internal Delay Enabled, 10/100 Mbps	1.2		ns

- (1) For RGMII, transmit selected signals include: rgmiiin\_txd[3:0] and rgmiiin\_txctl.
- (2) RGMII0 requires that the 4 data pins rgmii0\_txd[3:0] and rgmii0\_txctl have their board propagation delays matched within 50pS of rgmii0\_txc.
- (3) RGMII1 requires that the 4 data pins rgmii1\_txd[3:0] and rgmii1\_txctl have their board propagation delays matched within 50pS of rgmii1\_txc.

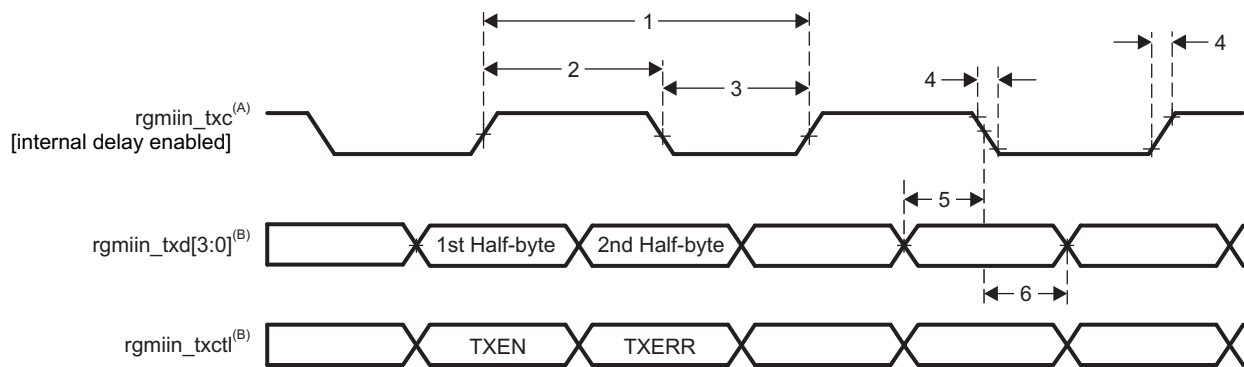

SPRS969G\_TIMING\_GMAC\_RGMII\_TX\_09

- A. TXC is delayed internally before being driven to the rgmiiin\_txc pin. This internal delay is always enabled.
- B. Data and control information is transmitted using both edges of the clocks. rgmiiin\_txd[3:0] carries data bits 3-0 on the rising edge of rgmiiin\_txc and data bits 7-4 on the falling edge of rgmiiin\_txc. Similarly, rgmiiin\_txctl carries TXEN on rising edge of rgmiiin\_txc and TXERR of falling edge of rgmiiin\_txc.

**Figure 5-69. GMAC Transmit Interface Timing RGMII operation**

In [Table 5-107](#) are presented the specific groupings of signals (IOSET) for use with GMAC RGMII signals.

**Table 5-107. GMAC RGMII IOSETs**

SIGNALS	IOSET3		IOSET4	
	BALL	MUX	BALL	MUX
<b>GMAC RGMII1</b>				
rgmii1_txd3	C11	3		
rgmii1_txd2	B12	3		
rgmii1_txd1	A12	3		
rgmii1_txd0	A13	3		
rgmii1_rxd3	B13	3		
rgmii1_rxd2	E13	3		
rgmii1_rxd1	C13	3		
rgmii1_rxd0	D13	3		
rgmii1_rxctl	F11	3		
rgmii1_txc	B11	3		
rgmii1_txctl	D11	3		

**Table 5-107. GMAC RGMII IOSETs (continued)**

SIGNALS	IOSET3		IOSET4	
	BALL	MUX	BALL	MUX
rgmii1_rxc	E11	3		
<b>GMAC RGMII0</b>				
rgmii0_txd3			P4	0
rgmii0_txd2			P3	0
rgmii0_txd1			R2	0
rgmii0_txd0			R1	0
rgmii0_rxd3			N1	0
rgmii0_rxd2			P1	0
rgmii0_rxd1			N3	0
rgmii0_rxd0			N4	0
rgmii0_txc			T4	0
rgmii0_rxctl			P2	0
rgmii0_rxc			N2	0
rgmii0_txctl			T5	0

**NOTE**

To configure the desired Manual IO Timing Mode the user must follow the steps described in section "*Manual IO Timing Modes*" of the Device TRM.

The associated registers to configure are listed in the **CFG REGISTER** column. For more information please see the *Control Module Chapter* in the Device TRM.

Manual IO Timings Modes must be used to ensure some IO timings for GMAC. See [Table 5-28 Modes Summary](#) for a list of IO timings requiring the use of Manual IO Timings Modes. See [Table 5-108 Manual Functions Mapping for GMAC RGMII0](#) for a definition of the Manual modes.

[Table 5-108](#) lists the A\_DELAY and G\_DELAY values needed to calculate the correct values to be set in the CFG\_x registers.

**Table 5-108. Manual Functions Mapping for GMAC RGMII0**

BALL	BALL NAME	GMAC_RGMII0_MANUAL1		CFG REGISTER	MUXMODE
		A_DELAY (ps)	G_DELAY (ps)		0
N2	rgmii0_rxc	413	0	CFG_RGMII0_RXC_IN	rgmii0_rxc
P2	rgmii0_rxctl	27	2296	CFG_RGMII0_RXCTL_IN	rgmii0_rxctl
N4	rgmii0_rxd0	3	1721	CFG_RGMII0_RXD0_IN	rgmii0_rxd0
N3	rgmii0_rxd1	134	1786	CFG_RGMII0_RXD1_IN	rgmii0_rxd1
P1	rgmii0_rxd2	40	1966	CFG_RGMII0_RXD2_IN	rgmii0_rxd2
N1	rgmii0_rxd3	0	2057	CFG_RGMII0_RXD3_IN	rgmii0_rxd3
T4	rgmii0_txc	0	60	CFG_RGMII0_TXC_OUT	rgmii0_txc
T5	rgmii0_txctl	0	60	CFG_RGMII0_TXCTL_OUT	rgmii0_txctl
R1	rgmii0_txd0	0	60	CFG_RGMII0_TXD0_OUT	rgmii0_txd0
R2	rgmii0_txd1	0	0	CFG_RGMII0_TXD1_OUT	rgmii0_txd1
P3	rgmii0_txd2	0	60	CFG_RGMII0_TXD2_OUT	rgmii0_txd2
P4	rgmii0_txd3	0	120	CFG_RGMII0_TXD3_OUT	rgmii0_txd3

Manual IO Timings Modes must be used to ensure some IO timings for GMAC. See [Table 5-28 Modes Summary](#) for a list of IO timings requiring the use of Manual IO Timings Modes. See [Table 5-109 Manual Functions Mapping for GMAC RGMII1](#) for a definition of the Manual modes.

[Table 5-109](#) lists the A\_DELAY and G\_DELAY values needed to calculate the correct values to be set in the CFG\_x registers.

**Table 5-109. Manual Functions Mapping for GMAC RGMII1**

BALL	BALL NAME	GMAC_RGMII1_MANUAL1		CFG REGISTER	MUXMODE
		A_DELAY (ps)	G_DELAY (ps)		3
<a href="#">E11</a>	vin2a_d18	530	0	CFG_VIN2A_D18_IN	rgmii1_rxc
<a href="#">F11</a>	vin2a_d19	71	1099	CFG_VIN2A_D19_IN	rgmii1_rxctl
<a href="#">B13</a>	vin2a_d20	142	1337	CFG_VIN2A_D20_IN	rgmii1_rxd3
<a href="#">E13</a>	vin2a_d21	114	1517	CFG_VIN2A_D21_IN	rgmii1_rxd2
<a href="#">C13</a>	vin2a_d22	171	1331	CFG_VIN2A_D22_IN	rgmii1_rxd1
<a href="#">D13</a>	vin2a_d23	0	1328	CFG_VIN2A_D23_IN	rgmii1_rxd0
<a href="#">B11</a>	vin2a_d12	0	0	CFG_VIN2A_D12_OUT	rgmii1_txc
<a href="#">D11</a>	vin2a_d13	170	0	CFG_VIN2A_D13_OUT	rgmii1_txctl
<a href="#">C11</a>	vin2a_d14	150	0	CFG_VIN2A_D14_OUT	rgmii1_txd3
<a href="#">B12</a>	vin2a_d15	0	0	CFG_VIN2A_D15_OUT	rgmii1_txd2
<a href="#">A12</a>	vin2a_d16	60	0	CFG_VIN2A_D16_OUT	rgmii1_txd1
<a href="#">A13</a>	vin2a_d17	60	0	CFG_VIN2A_D17_OUT	rgmii1_txd0

### 5.10.6.20 eMMC/SD/SDIO

The Device includes the following external memory interfaces 4 MultiMedia Card/Secure Digital/Secure Digital Input Output Interface (MMC/SD/SDIO)

---

#### NOTE

The eMMC/SD/SDIO<sub>i</sub> (i = 1 to 4) controller is also referred to as MMC<sub>i</sub>.

---

#### 5.10.6.20.1 MMC1—SD Card Interface

MMC1 interface is compliant with the SD Standard v3.01 and it supports the following SD Card applications:

- Default speed, 4-bit data, SDR, half-cycle
- High speed, 4-bit data, SDR, half-cycle
- SDR12, 4-bit data, half-cycle
- SDR25, 4-bit data, half-cycle
- UHS-I SDR50, 4-bit data, half-cycle
- UHS-I SDR104, 4-bit data, half-cycle
- UHS-I DDR50, 4-bit data

---

#### NOTE

For more information, see the eMMC/SD/SDIO chapter of the Device TRM.

---

##### 5.10.6.20.1.1 Default speed, 4-bit data, SDR, half-cycle

Table 5-110 and Table 5-111 present Timing requirements and Switching characteristics for MMC1 - Default Speed in receiver and transmitter mode (see Figure 5-70 and Figure 5-71).

**Table 5-110. Timing Requirements for MMC1 - SD Card Default Speed Mode**

NO.	PARAMETER	DESCRIPTION	MIN	MAX	UNIT
DSSD5	$t_{su(cmdV-clkH)}$	Setup time, mmc1_cmd valid before mmc1_clk rising clock edge	5.11		ns
DSSD6	$t_{h(clkH-cmdV)}$	Hold time, mmc1_cmd valid after mmc1_clk rising clock edge	20.46		ns
DSSD7	$t_{su(dV-clkH)}$	Setup time, mmc1_dat[3:0] valid before mmc1_clk rising clock edge	5.11		ns
DSSD8	$t_{h(clkH-dV)}$	Hold time, mmc1_dat[3:0] valid after mmc1_clk rising clock edge	20.46		ns

**Table 5-111. Switching Characteristics for MMC1 - SD Card Default Speed Mode**

NO.	PARAMETER	DESCRIPTION	MIN	MAX	UNIT
DSSD0	fop(clk)	Operating frequency, mmc1_clk		24	MHz
DSSD1	$t_{w(clkH)}$	Pulse duration, mmc1_clk high	0.5 × P-0.185 <sup>(1)</sup>		ns
DSSD2	$t_{w(clkL)}$	Pulse duration, mmc1_clk low	0.5 × P-0.185 <sup>(1)</sup>		ns
DSSD3	$t_{d(clkL-cmdV)}$	Delay time, mmc1_clk falling clock edge to mmc1_cmd transition	-14.93	14.93	ns
DSSD4	$t_{d(clkL-dV)}$	Delay time, mmc1_clk falling clock edge to mmc1_dat[3:0] transition	-14.93	14.93	ns

(1) P = output mmc1\_clk period in ns

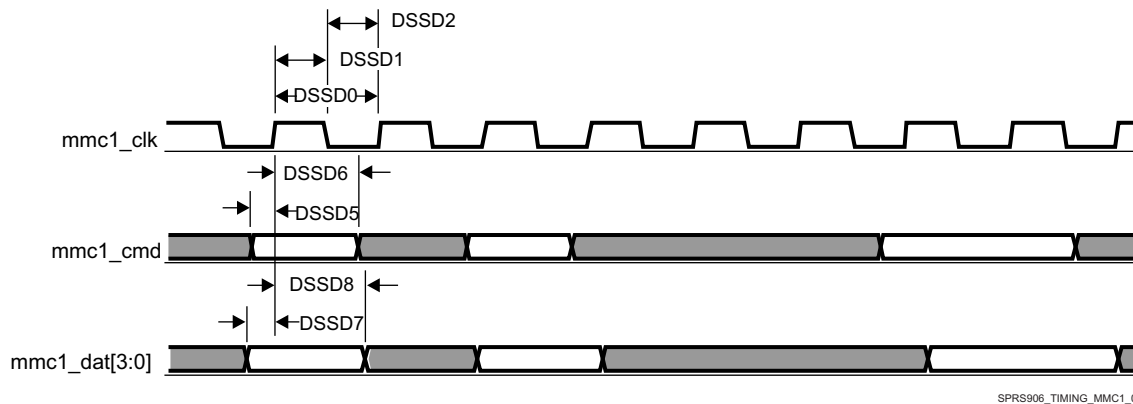

SPRS906\_TIMING\_MMC1\_01

**Figure 5-70. MMC/SD/SDIO in - Default Speed - Receiver Mode**

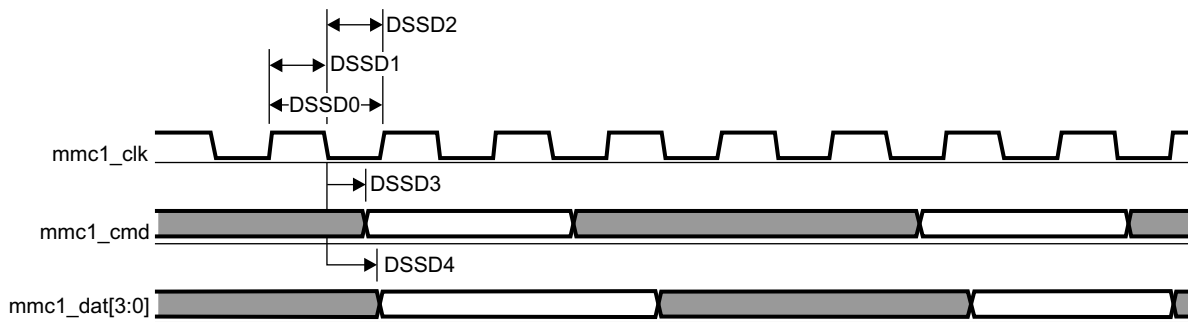

SPRS906\_TIMING\_MMC1\_02

**Figure 5-71. MMC/SD/SDIO in - Default Speed - Transmitter Mode**

#### 5.10.6.20.1.2 High speed, 4-bit data, SDR, half-cycle

Table 5-112 and Table 5-113 present Timing requirements and Switching characteristics for MMC1 - High Speed in receiver and transmitter mode (see Figure 5-72 and Figure 5-73).

**Table 5-112. Timing Requirements for MMC1 - SD Card High Speed**

NO.	PARAMETER	DESCRIPTION	MIN	MAX	UNIT
HSSD3	$t_{su}(cmdV-clkH)$	Setup time, mmc1_cmd valid before mmc1_clk rising clock edge	5.3		ns
HSSD4	$t_h(clkH-cmdV)$	Hold time, mmc1_cmd valid after mmc1_clk rising clock edge	2.6		ns
HSSD7	$t_{su}(dV-clkH)$	Setup time, mmc1_dat[3:0] valid before mmc1_clk rising clock edge	5.3		ns
HSSD8	$t_h(clkH-dV)$	Hold time, mmc1_dat[3:0] valid after mmc1_clk rising clock edge	2.6		ns

**Table 5-113. Switching Characteristics for MMC1 - SD Card High Speed**

NO.	PARAMETER	DESCRIPTION	MIN	MAX	UNIT
HSSD1	fop(clk)	Operating frequency, mmc1_clk		48	MHz
HSSD2H	$t_w(clkH)$	Pulse duration, mmc1_clk high	$0.5 \times P - 0.185$ <sup>(1)</sup>		ns
HSSD2L	$t_w(clkL)$	Pulse duration, mmc1_clk low	$0.5 \times P - 0.185$ <sup>(1)</sup>		ns
HSSD5	$t_d(clkL-cmdV)$	Delay time, mmc1_clk falling clock edge to mmc1_cmd transition	-7.6	3.6	ns
HSSD6	$t_d(clkL-dV)$	Delay time, mmc1_clk falling clock edge to mmc1_dat[3:0] transition	-7.6	3.6	ns



(1) P = output mmc1\_clk period in ns



Figure 5-72. MMC/SD/SDIO in - High Speed - Receiver Mode

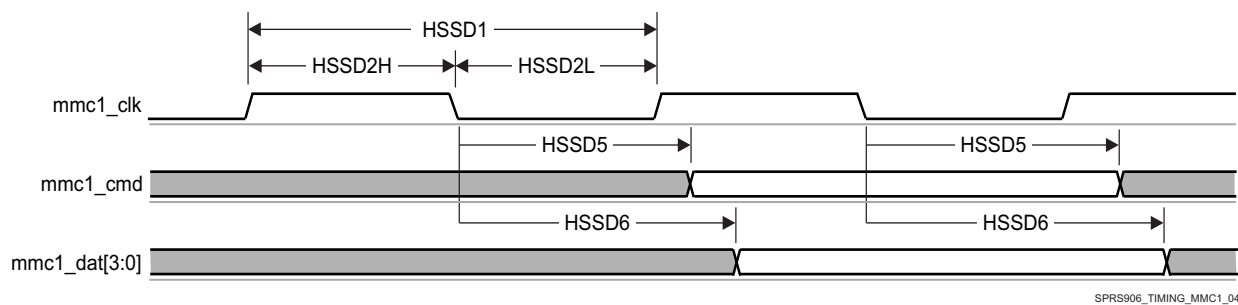

Figure 5-73. MMC/SD/SDIO in - High Speed - Transmitter Mode

5.10.6.20.1.3 SDR12, 4-bit data, half-cycle

Table 5-114 and Table 5-115 present Timing requirements and Switching characteristics for MMC1 - SDR12 in receiver and transmitter mode (see Figure 5-74 and Figure 5-75).

Table 5-114. Timing Requirements for MMC1 - SD Card SDR12 Mode

NO.	PARAMETER	DESCRIPTION	MODE	MIN	MAX	UNIT
SDR12 5	$t_{su(cmdV-clkH)}$	Setup time, mmc1_cmd valid before mmc1_clk rising clock edge		25.99		ns
SDR12 6	$t_h(clkH-cmdV)$	Hold time, mmc1_cmd valid after mmc1_clk rising clock edge	Pad Loopback Clock	1.6		ns
			Internal Loopback Clock	1.6		ns
SDR12 7	$t_{su(dV-clkH)}$	Setup time, mmc1_dat[3:0] valid before mmc1_clk rising clock edge		25.99		ns
SDR12 8	$t_h(clkH-dV)$	Hold time, mmc1_dat[3:0] valid after mmc1_clk rising clock edge	Pad Loopback Clock	1.6		ns
			Internal Loopback Clock	1.6		ns

Table 5-115. Switching Characteristics for MMC1 - SD Card SDR12 Mode

NO.	PARAMETER	DESCRIPTION	MIN	MAX	UNIT
SDR120	fop(clk)	Operating frequency, mmc1_clk		24	MHz
SDR121	$t_w(clkH)$	Pulse duration, mmc1_clk high	$0.5 \times P - 0.185^{(1)}$		ns
SDR122	$t_w(clkL)$	Pulse duration, mmc1_clk low	$0.5 \times P - 0.185^{(1)}$		ns
SDR123	$t_d(clkL-cmdV)$	Delay time, mmc1_clk falling clock edge to mmc1_cmd transition	-19.13	16.93	ns
SDR124	$t_d(clkL-dV)$	Delay time, mmc1_clk falling clock edge to mmc1_dat[3:0] transition	-19.13	16.93	ns

(1) P = output mmc1\_clk period in ns

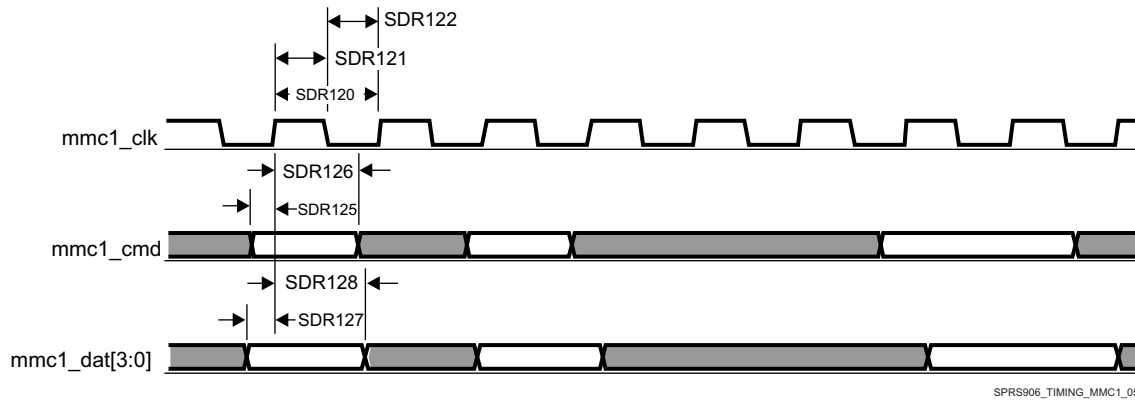

Figure 5-74. MMC/SD/SDIO in - High Speed SDR12 - Receiver Mode

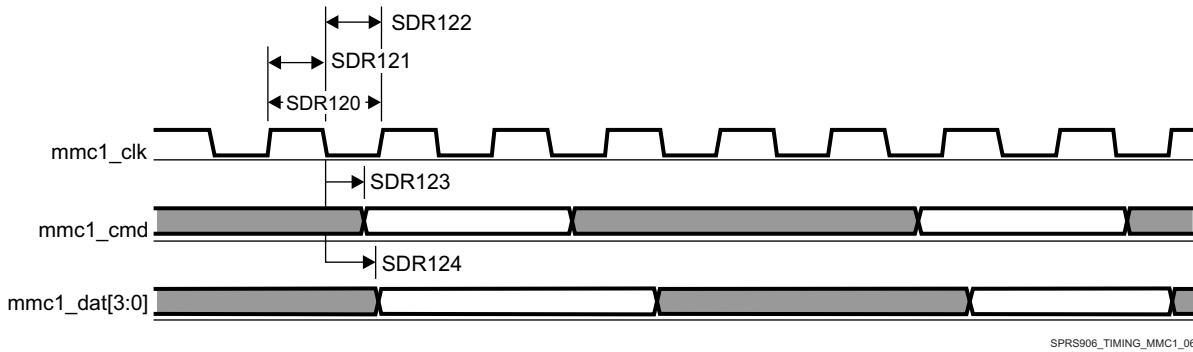

Figure 5-75. MMC/SD/SDIO in - High Speed SDR12 - Transmitter Mode

5.10.6.20.1.4 SDR25, 4-bit data, half-cycle

Table 5-116 and Table 5-117 present Timing requirements and Switching characteristics for MMC1 - SDR25 in receiver and transmitter mode (see Figure 5-76 and Figure 5-77).

Table 5-116. Timing Requirements for MMC1 - SD Card SDR25 Mode

NO.	PARAMETER	DESCRIPTION	MODE	MIN	MAX	UNIT
SDR25 3	$t_{su(cmdV-clkH)}$	Setup time, mmc1_cmd valid before mmc1_clk rising clock edge		5.3		ns
SDR25 4	$t_h(clkH-cmdV)$	Hold time, mmc1_cmd valid after mmc1_clk rising clock edge		1.6		ns
SDR25 7	$t_{su(dV-clkH)}$	Setup time, mmc1_dat[3:0] valid before mmc1_clk rising clock edge		5.3		ns
SDR25 8	$t_h(clkH-dV)$	Hold time, mmc1_dat[3:0] valid after mmc1_clk rising clock edge	Pad Loopback Clock	1.6		ns
			Internal Loopback Clock	1.6		ns

Table 5-117. Switching Characteristics for MMC1 - SD Card SDR25 Mode

NO.	PARAMETER	DESCRIPTION	MIN	MAX	UNIT
SDR251	fop(clk)	Operating frequency, mmc1_clk		48	MHz
SDR252 H	$t_w(clkH)$	Pulse duration, mmc1_clk high	$0.5 \times P - 0.185$ (1)		ns
SDR252L	$t_w(clkL)$	Pulse duration, mmc1_clk low	$0.5 \times P - 0.185$ (1)		ns
SDR255	$t_d(clkL-cmdV)$	Delay time, mmc1_clk falling clock edge to mmc1_cmd transition	-8.8	6.6	ns

**Table 5-117. Switching Characteristics for MMC1 - SD Card SDR25 Mode (continued)**

NO.	PARAMETER	DESCRIPTION	MIN	MAX	UNIT
SDR256	$t_{d(\text{clkL-dV})}$	Delay time, mmc1_clk falling clock edge to mmc1_dat[3:0] transition	-8.8	6.6	ns

(1) P = output mmc1\_clk period in ns

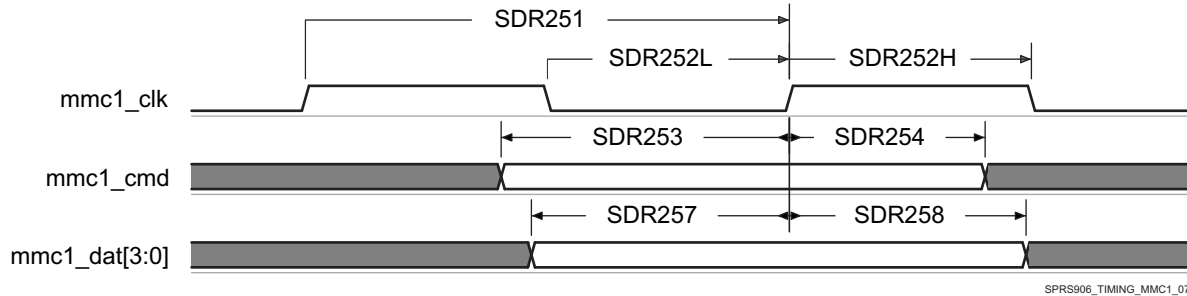

**Figure 5-76. MMC/SD/SDIO in - High Speed SDR25 - Receiver Mode**

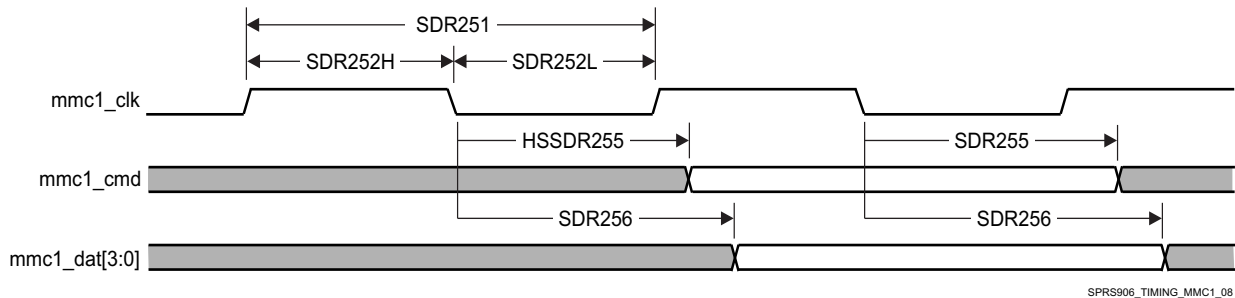

**Figure 5-77. MMC/SD/SDIO in - High Speed SDR25 - Transmitter Mode**

**5.10.6.20.1.5 UHS-I SDR50, 4-bit data, half-cycle**

Table 5-118 and Table 5-119 present Timing requirements and Switching characteristics for MMC1 - SDR50 in receiver and transmitter mode (see Figure 5-78 and Figure 5-79).

**Table 5-118. Timing Requirements for MMC1 - SD Card SDR50 Mode**

NO.	PARAMETER	DESCRIPTION	MODE	MIN	MAX	UNIT
SDR503	$t_{su(\text{cmdV-clkH})}$	Setup time, mmc1_cmd valid before mmc1_clk rising clock edge		1.48		ns
SDR504	$t_{h(\text{clkH-cmdV})}$	Hold time, mmc1_cmd valid after mmc1_clk rising clock edge		1.7		ns
SDR507	$t_{su(\text{dV-clkH})}$	Setup time, mmc1_dat[3:0] valid before mmc1_clk rising clock edge		1.48		ns
SDR508	$t_{h(\text{clkH-dV})}$	Hold time, mmc1_dat[3:0] valid after mmc1_clk rising clock edge	Pad Loopback Clock	1.7		ns
			Internal Loopback Clock	1.6		ns

**Table 5-119. Switching Characteristics for MMC1 - SD Card SDR50 Mode**

NO.	PARAMETER	DESCRIPTION	MIN	MAX	UNIT
SDR501	fop(clk)	Operating frequency, mmc1_clk		96	MHz
SDR502H	$t_{w(\text{clkH})}$	Pulse duration, mmc1_clk high	$0.5 \times P - 0.185$ (1)		ns
SDR502L	$t_{w(\text{clkL})}$	Pulse duration, mmc1_clk low	$0.5 \times P - 0.185$ (1)		ns
SDR505	$t_{d(\text{clkL-cmdV})}$	Delay time, mmc1_clk falling clock edge to mmc1_cmd transition	-8.8	6.6	ns
SDR506	$t_{d(\text{clkL-dV})}$	Delay time, mmc1_clk falling clock edge to mmc1_dat[3:0] transition	-3.66	1.46	ns

(1) P = output mmc1\_clk period in ns

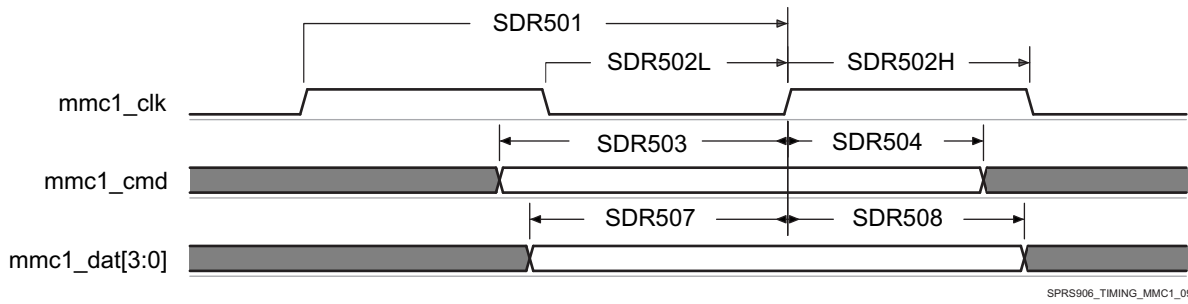

Figure 5-78. MMC/SD/SDIO in - High Speed SDR50 - Receiver Mode

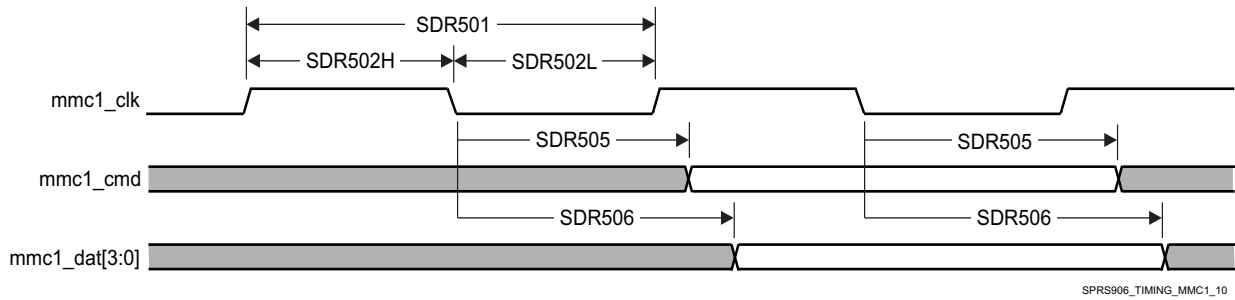

Figure 5-79. MMC/SD/SDIO in - High Speed SDR50 - Transmitter Mode

5.10.6.20.1.6 UHS-I SDR104, 4-bit data, half-cycle

Table 5-120 presents Timing requirements and Switching characteristics for MMC1 - SDR104 in receiver and transmitter mode (see Figure 5-80 and Figure 5-81).

Table 5-120. Switching Characteristics for MMC1 - SD Card SDR104 Mode

NO.	PARAMETER	DESCRIPTION	MIN	MAX	UNIT
SDR1041	fop(clk)	Operating frequency, mmc1_clk		192	MHz
SDR1042 H	t <sub>w</sub> (clkH)	Pulse duration, mmc1_clk high	0.5 × P-0.185 <sup>(1)</sup>		ns
SDR1042 L	t <sub>w</sub> (clkL)	Pulse duration, mmc1_clk low	0.5 × P-0.185 <sup>(1)</sup>		ns
SDR1045	t <sub>d</sub> (clkL-cmdV)	Delay time, mmc1_clk falling clock edge to mmc1_cmd transition	-1.09	0.49	ns
SDR1046	t <sub>d</sub> (clkL-dV)	Delay time, mmc1_clk falling clock edge to mmc1_dat[3:0] transition	-1.09	0.49	ns

(1) P = output mmc1\_clk period in ns

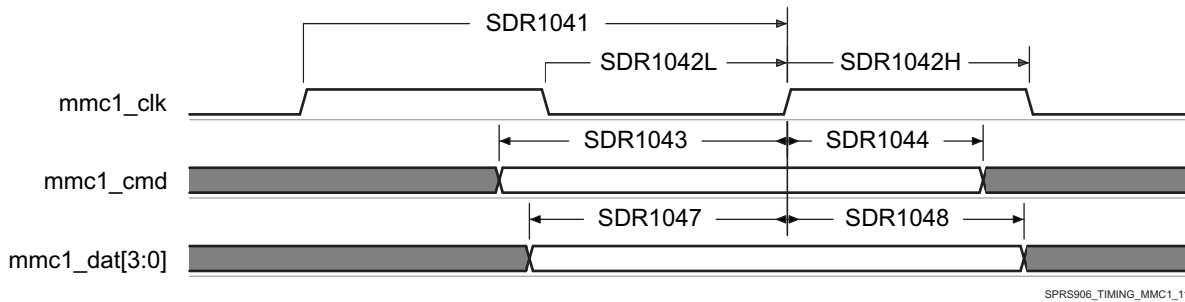

Figure 5-80. MMC/SD/SDIO in - High Speed SDR104 - Receiver Mode

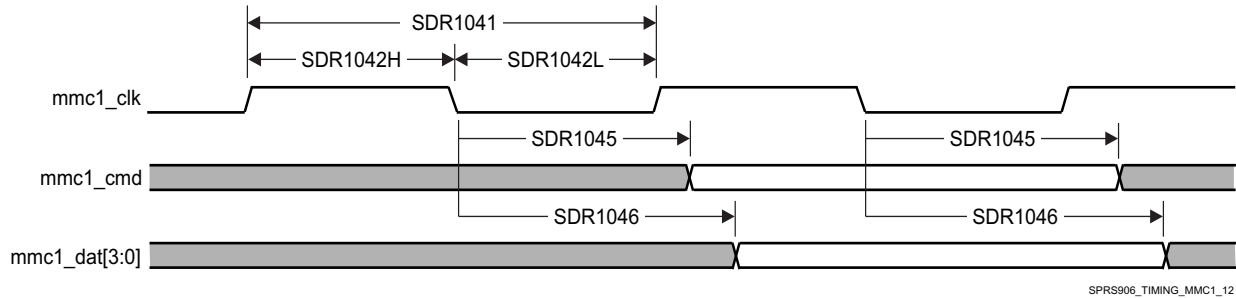

Figure 5-81. MMC/SD/SDIO in - High Speed SDR104 - Transmitter Mode

5.10.6.20.1.7 UHS-I DDR50, 4-bit data

Table 5-121 and Table 5-122 present Timing requirements and Switching characteristics for MMC1 - DDR50 in receiver and transmitter mode (see Figure 5-82 and Figure 5-83).

Table 5-121. Timing Requirements for MMC1 - SD Card DDR50 Mode

NO.	PARAMETER	DESCRIPTION	MODE	MIN	MAX	UNIT
DDR50 5	$t_{su(cmdV-clk)}$	Setup time, mmc1_cmd valid before mmc1_clk transition		1.79		ns
DDR50 6	$t_h(clk-cmdV)$	Hold time, mmc1_cmd valid after mmc1_clk transition		2		ns
DDR50 7	$t_{su(dV-clk)}$	Setup time, mmc1_dat[3:0] valid before mmc1_clk transition	Pad Loopback	1.79		ns
			Internal Loopback	1.79		ns
DDR50 8	$t_h(clk-dV)$	Hold time, mmc1_dat[3:0] valid after mmc1_clk transition	Pad Loopback	2		ns
			Internal Loopback	1.6		ns

Table 5-122. Switching Characteristics for MMC1 - SD Card DDR50 Mode

NO.	PARAMETER	DESCRIPTION	MIN	MAX	UNIT
DDR500	fop(clk)	Operating frequency, mmc1_clk		48	MHz
DDR501	$t_w(clkH)$	Pulse duration, mmc1_clk high	$0.5 \times P - 0.185$ (1)		ns
DDR502	$t_w(clkL)$	Pulse duration, mmc1_clk low	$0.5 \times P - 0.185$ (1)		ns
DDR503	$t_d(clk-cmdV)$	Delay time, mmc1_clk transition to mmc1_cmd transition	1.225	6.6	ns
DDR504	$t_d(clk-dV)$	Delay time, mmc1_clk transition to mmc1_dat[3:0] transition	1.225	6.6	ns

(1) P = output mmc1\_clk period in ns

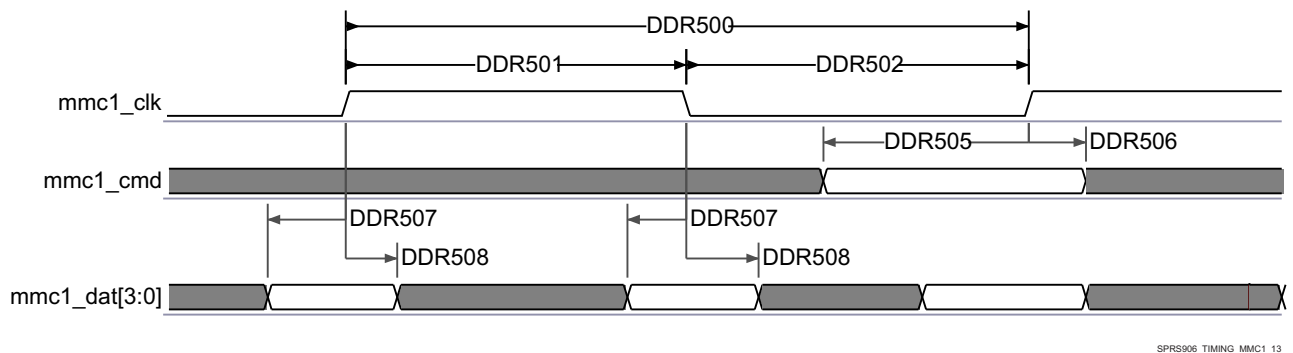
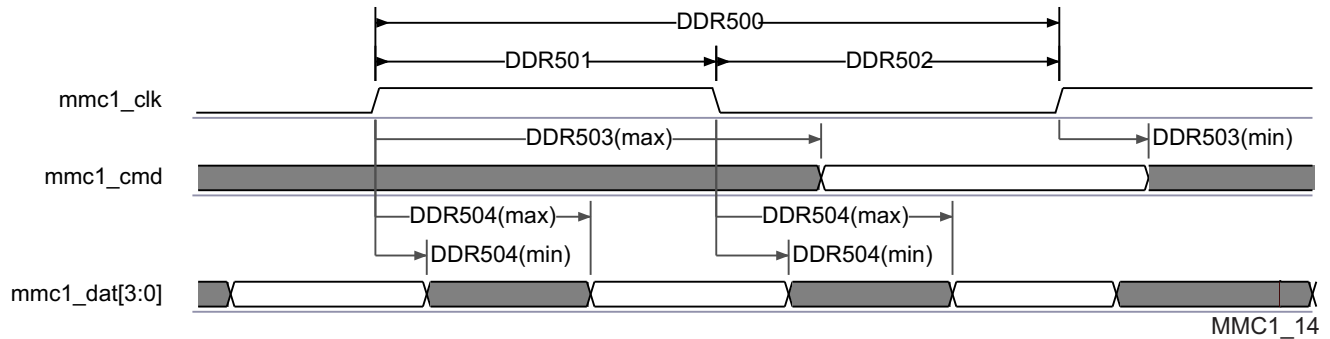

Figure 5-82. SDMMC - High Speed SD - DDR - Data/Command Receive



**Figure 5-83. SDMMC - High Speed SD - DDR - Data/Command Transmit**

**NOTE**

To configure the desired virtual mode the user must set MODESELECT bit and DELAYMODE bitfield for each corresponding pad control register.

The pad control registers are presented in [Table 4-27](#) and described in Device TRM, *Control Module Chapter*.

Virtual IO Timings Modes must be used to ensure some IO timings for MMC1. See [Table 5-28 Modes Summary](#) for a list of IO timings requiring the use of Virtual IO Timings Modes. See [Table 5-123 Virtual Functions Mapping for MMC1](#) for a definition of the Virtual modes.

[Table 5-123](#) presents the values for DELAYMODE bitfield.

**Table 5-123. Virtual Functions Mapping for MMC1**

BALL	BALL NAME	Delay Mode Value				MUXMODE
		MMC1_VIRTUAL1	MMC1_VIRTUAL4	MMC1_VIRTUAL5	MMC1_VIRTUAL6	0
U3	mmc1_clk	15	12	11	10	mmc1_clk
V4	mmc1_cmd	15	12	11	10	mmc1_cmd
V3	mmc1_dat0	15	12	11	10	mmc1_dat0
V2	mmc1_dat1	15	12	11	10	mmc1_dat1
W1	mmc1_dat2	15	12	11	10	mmc1_dat2
V1	mmc1_dat3	15	12	11	10	mmc1_dat3

**NOTE**

To configure the desired Manual IO Timing Mode the user must follow the steps described in section Manual IO Timing Modes of the Device TRM.

The associated registers to configure are listed in the **CFG REGISTER** column. For more information see the Control Module chapter in the Device TRM.

Manual IO Timings Modes must be used to ensure some IO timings for MMC1. See [Table 5-28 Modes Summary](#) for a list of IO timings requiring the use of Manual IO Timings Modes. See [Table 5-124 Manual Functions Mapping for MMC1](#) for a definition of the Manual modes.

[Table 5-124](#) lists the A\_DELAY and G\_DELAY values needed to calculate the correct values to be set in the CFG\_x registers.

**Table 5-124. Manual Functions Mapping for MMC1**

BALL	BALL NAME	MMC1_MANUAL1		MMC1_MANUAL2		CFG REGISTER	MUXMODE
		A_DELAY (ps)	G_DELAY (ps)	A_DELAY (ps)	G_DELAY (ps)		0
U3	mmc1_clk	588	0	-	-	CFG_MMC1_CLK_IN	mmc1_clk
V4	mmc1_cmd	1000	0	-	-	CFG_MMC1_CMD_IN	mmc1_cmd
V3	mmc1_dat0	1375	0	-	-	CFG_MMC1_DAT0_IN	mmc1_dat0
V2	mmc1_dat1	1000	0	-	-	CFG_MMC1_DAT1_IN	mmc1_dat1
W1	mmc1_dat2	1000	0	-	-	CFG_MMC1_DAT2_IN	mmc1_dat2
V1	mmc1_dat3	1000	0	-	-	CFG_MMC1_DAT3_IN	mmc1_dat3
U3	mmc1_clk	1230	0	520	320	CFG_MMC1_CLK_OUT	mmc1_clk
V4	mmc1_cmd	0	0	0	0	CFG_MMC1_CMD_OUT	mmc1_cmd
V3	mmc1_dat0	56	0	40	0	CFG_MMC1_DAT0_OUT	mmc1_dat0
V2	mmc1_dat1	76	0	83	0	CFG_MMC1_DAT1_OUT	mmc1_dat1
W1	mmc1_dat2	91	0	98	0	CFG_MMC1_DAT2_OUT	mmc1_dat2
V1	mmc1_dat3	99	0	106	0	CFG_MMC1_DAT3_OUT	mmc1_dat3
V4	mmc1_cmd	0	0	51	0	CFG_MMC1_CMD_OEN	mmc1_cmd
V3	mmc1_dat0	0	0	0	0	CFG_MMC1_DAT0_OEN	mmc1_dat0
V2	mmc1_dat1	0	0	363	0	CFG_MMC1_DAT1_OEN	mmc1_dat1
W1	mmc1_dat2	0	0	199	0	CFG_MMC1_DAT2_OEN	mmc1_dat2
V1	mmc1_dat3	0	0	273	0	CFG_MMC1_DAT3_OEN	mmc1_dat3

**5.10.6.20.2 MMC2 — eMMC**

MMC2 interface is compliant with the JC64 eMMC Standard v4.5 and it supports the following eMMC applications:

- Standard JC64 SDR, 8-bit data, half cycle
- High-speed JC64 SDR, 8-bit data, half cycle
- High-speed HS200 JEDS84, 8-bit data, half cycle
- High-speed JC64 DDR, 8-bit data

**NOTE**

For more information, see the eMMC/SD/SDIO chapter of the Device TRM.

### 5.10.6.20.2.1 Standard JC64 SDR, 8-bit data, half cycle

Table 5-125 and Table 5-126 present Timing requirements and Switching characteristics for MMC2 - Standard SDR in receiver and transmitter mode (see Figure 5-84 and Figure 5-85).

**Table 5-125. Timing Requirements for MMC2 - JC64 Standard SDR Mode**

NO.	PARAMETER	DESCRIPTION	MIN	MAX	UNIT
SSDR5	$t_{su}(cmdV-clkH)$	Setup time, mmc2_cmd valid before mmc2_clk rising clock edge	13.19		ns
SSDR6	$t_h(clkH-cmdV)$	Hold time, mmc2_cmd valid after mmc2_clk rising clock edge	8.4		ns
SSDR7	$t_{su}(dV-clkH)$	Setup time, mmc2_dat[7:0] valid before mmc2_clk rising clock edge	13.19		ns
SSDR8	$t_h(clkH-dV)$	Hold time, mmc2_dat[7:0] valid after mmc2_clk rising clock edge	8.4		ns



**Table 5-126. Switching Characteristics for MMC2 - JC64 Standard SDR Mode**

NO.	PARAMETER	DESCRIPTION	MIN	MAX	UNIT
SSDR1	fop(clk)	Operating frequency, mmc2_clk		24	MHz
SSDR2H	t <sub>w</sub> (clkH)	Pulse duration, mmc2_clk high	0.5 × P-0.172 <sup>(1)</sup>		ns
SSDR2L	t <sub>w</sub> (clkL)	Pulse duration, mmc2_clk low	0.5 × P-0.172 <sup>(1)</sup>		ns
SSDR3	t <sub>d</sub> (clkL-cmdV)	Delay time, mmc2_clk falling clock edge to mmc2_cmd transition	-16.96	16.96	ns
SSDR4	t <sub>d</sub> (clkL-dV)	Delay time, mmc2_clk falling clock edge to mmc2_dat[7:0] transition	-16.96	16.96	ns

(1) P = output mmc2\_clk period in ns

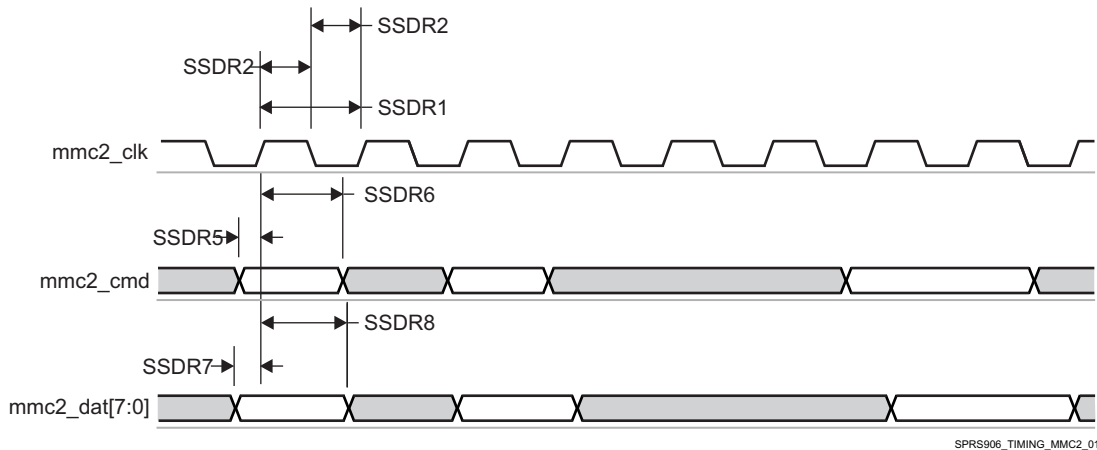

SPRS906\_TIMING\_MMC2\_01

**Figure 5-84. MMC/SD/SDIO in - Standard JC64 - Receiver Mode**

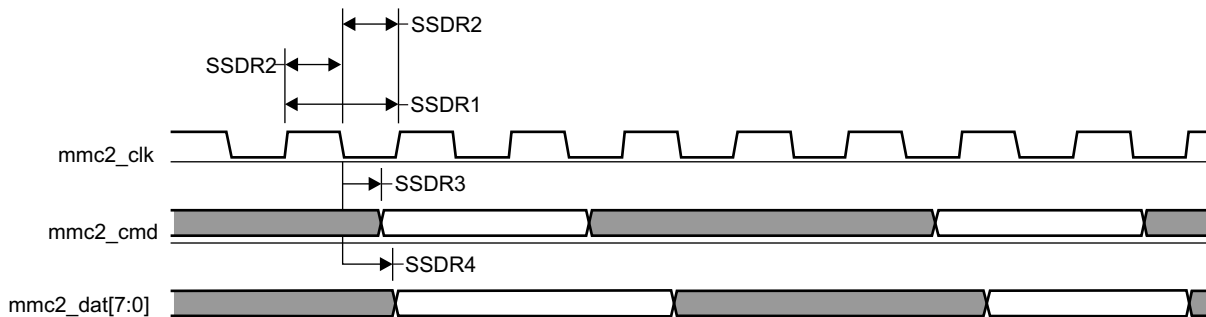

SPRS906\_TIMING\_MMC2\_02

**Figure 5-85. MMC/SD/SDIO in - Standard JC64 - Transmitter Mode**

**5.10.6.20.2 High-speed JC64 SDR, 8-bit data, half cycle**

Table 5-127 and Table 5-128 present Timing requirements and Switching characteristics for MMC2 - High speed SDR in receiver and transmitter mode (see Figure 5-86 and Figure 5-87).

**Table 5-127. Timing Requirements for MMC2 - JC64 High Speed SDR Mode**

NO.	PARAMETER	DESCRIPTION	MIN	MAX	UNIT
JC643	t <sub>su</sub> (cmdV-clkH)	Setup time, mmc2_cmd valid before mmc2_clk rising clock edge	5.6		ns
JC644	t <sub>h</sub> (clkH-cmdV)	Hold time, mmc2_cmd valid after mmc2_clk rising clock edge	2.6		ns
JC647	t <sub>su</sub> (dV-clkH)	Setup time, mmc2_dat[7:0] valid before mmc2_clk rising clock edge	5.6		ns
JC648	t <sub>h</sub> (clkH-dV)	Hold time, mmc2_dat[7:0] valid after mmc2_clk rising clock edge	2.6		ns

**Table 5-128. Switching Characteristics for MMC2 - JC64 High Speed SDR Mode**

NO.	PARAMETER	DESCRIPTION	MIN	MAX	UNIT
JC641	fop(clk)	Operating frequency, mmc2_clk		48	MHz
JC642H	t <sub>w</sub> (clkH)	Pulse duration, mmc2_clk high	0.5 × P-0.172 <sup>(1)</sup>		ns
JC642L	t <sub>w</sub> (clkL)	Pulse duration, mmc2_clk low	0.5 × P-0.172 <sup>(1)</sup>		ns
JC645	t <sub>d</sub> (clkL-cmdV)	Delay time, mmc2_clk falling clock edge to mmc2_cmd transition	-6.64	6.64	ns
JC646	t <sub>d</sub> (clkL-dV)	Delay time, mmc2_clk falling clock edge to mmc2_dat[7:0] transition	-6.64	6.64	ns

(1) P = output mmc2\_clk period in ns

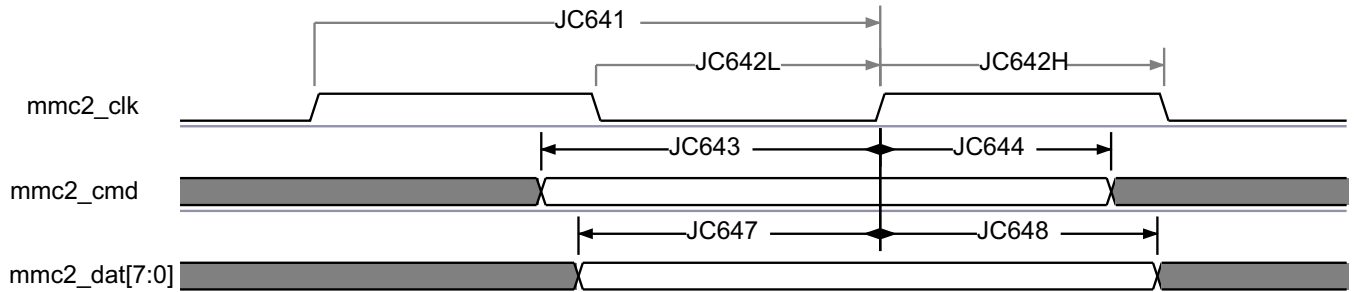

SPRS906\_TIMING\_MMC2\_03

**Figure 5-86. MMC/SD/SDIO in - High Speed JC64 - Receiver Mode**

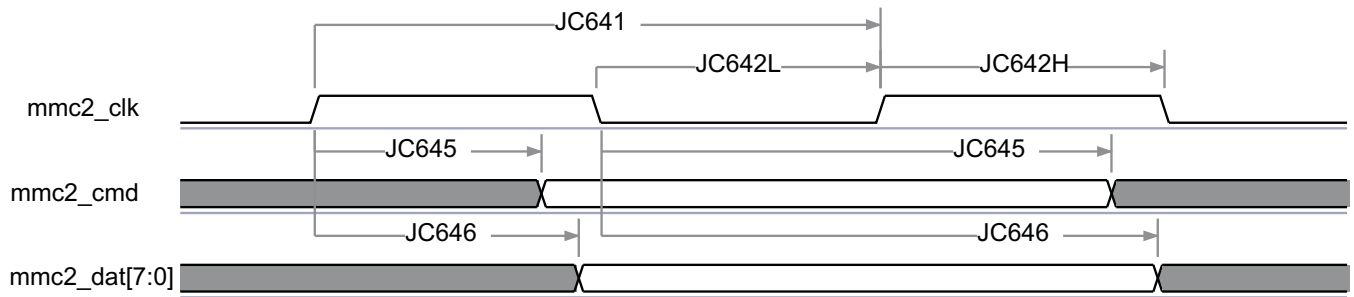

MMC2\_04

**Figure 5-87. MMC/SD/SDIO in - High Speed JC64 - transmitter Mode**

**5.10.6.20.2.3 High-speed HS200 JEDS84 SDR, 8-bit data, half cycle**

Table 5-129 presents Switching characteristics for MMC2 - HS200 in transmitter mode (see Figure 5-88).

**Table 5-129. Switching Characteristics for MMC2 - JEDS84 HS200 Mode**

NO.	PARAMETER	DESCRIPTION	MIN	MAX	UNIT
HS2001	fop(clk)	Operating frequency, mmc2_clk		192	MHz
HS2002H	t <sub>w</sub> (clkH)	Pulse duration, mmc2_clk high	0.5 × P-0.172 <sup>(1)</sup>		ns
HS2002L	t <sub>w</sub> (clkL)	Pulse duration, mmc2_clk low	0.5 × P-0.172 <sup>(1)</sup>		ns
HS2005	t <sub>d</sub> (clkL-cmdV)	Delay time, mmc2_clk falling clock edge to mmc2_cmd transition	-1.136	0.536	ns
HS2006	t <sub>d</sub> (clkL-dV)	Delay time, mmc2_clk falling clock edge to mmc2_dat[7:0] transition	-1.136	0.536	ns

(1) P = output mmc2\_clk period in ns

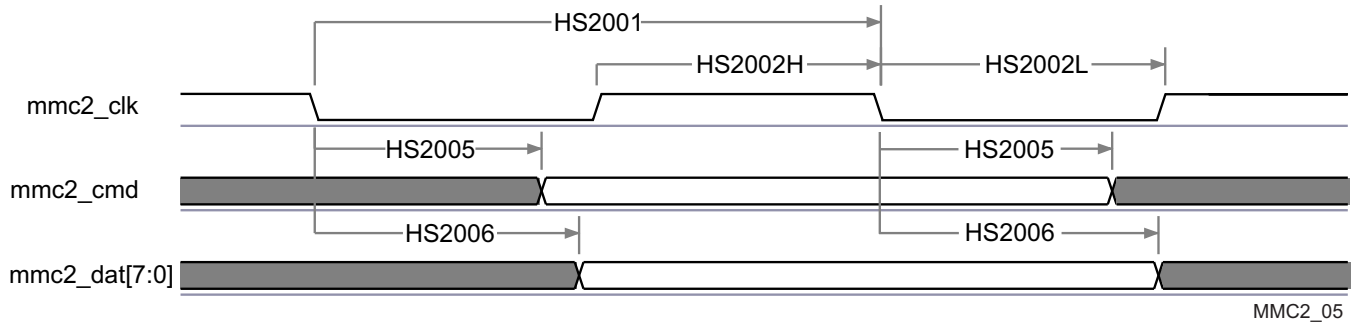

**Figure 5-88. eMMC in - HS200 SDR - Transmitter Mode**

**5.10.6.20.2.4 High-speed JC64 DDR, 8-bit data**

Table 5-130 and Table 5-131 present Timing requirements and Switching characteristics for MMC2 - High speed DDR in receiver and transmitter mode (see Figure 5-89 and Figure 5-90).

**Table 5-130. Timing Requirements for MMC2 - JC64 High Speed DDR Mode**

NO.	PARAMETER	DESCRIPTION	MODE	MIN	MAX	UNIT
DDR3	t <sub>su</sub> (cmdV-clk)	Setup time, mmc2_cmd valid before mmc2_clk transition		1.8		ns
DDR4	t <sub>h</sub> (clk-cmdV)	Hold time, mmc2_cmd valid after mmc2_clk transition		1.6		ns
DDR7	t <sub>su</sub> (dV-clk)	Setup time, mmc2_dat[7:0] valid before mmc2_clk transition		1.8		ns
DDR8	t <sub>h</sub> (clk-dV)	Hold time, mmc2_dat[7:0] valid after mmc2_clk transition	Pad Loopback (1.8V and 3.3V), Boot	1.6		ns
			Internal Loopback (1.8V with MMC2_VIRTUAL2)	1.86		ns
			Internal Loopback (3.3V with MMC2_VIRTUAL2)	1.95		ns
			Internal Loopback (1.8V with MMC2_MANUAL2)			ns
			Internal Loopback (3.3V with MMC2_MANUAL2)	1.6		ns

**Table 5-131. Switching Characteristics for MMC2 - JC64 High Speed DDR Mode**

NO.	PARAMETER	DESCRIPTION	MIN	MAX	UNIT
DDR1	fop(clk)	Operating frequency, mmc2_clk		48	MHz
DDR2H	t <sub>w</sub> (clkH)	Pulse duration, mmc2_clk high	0.5 × P-0.172 <sup>(1)</sup>		ns
DDR2L	t <sub>w</sub> (clkL)	Pulse duration, mmc2_clk low	0.5 × P-0.172 <sup>(1)</sup>		ns

**Table 5-131. Switching Characteristics for MMC2 - JC64 High Speed DDR Mode (continued)**

NO.	PARAMETER	DESCRIPTION	MIN	MAX	UNIT
DDR5	$t_{d(\text{clk-cmdV})}$	Delay time, mmc2_clk transition to mmc2_cmd transition	2.9	7.14	ns
DDR6	$t_{d(\text{clk-dV})}$	Delay time, mmc2_clk transition to mmc2_dat[7:0] transition	2.9	7.14	ns

(1) P = output mmc2\_clk period in ns

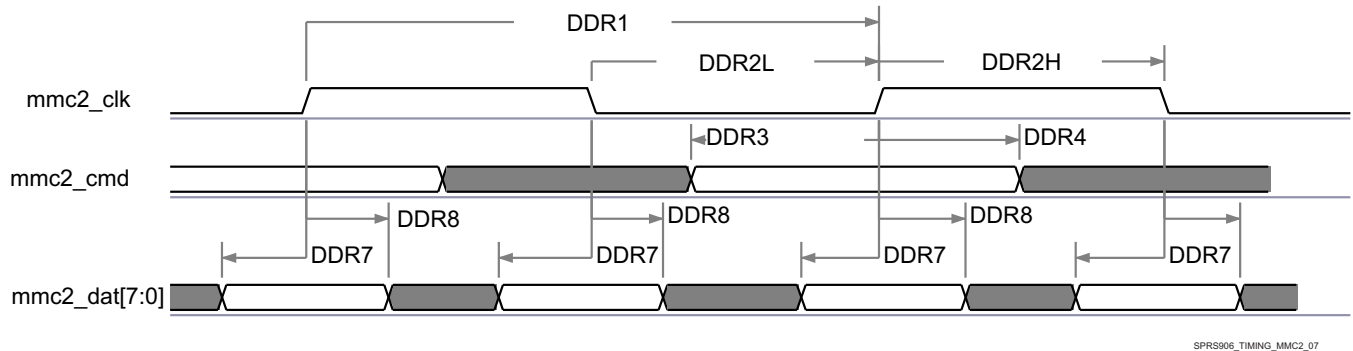

SPRS906\_TIMING\_MMC2\_07

**Figure 5-89. MMC/SD/SDIO in - High Speed DDR JC64 - Receiver Mode**

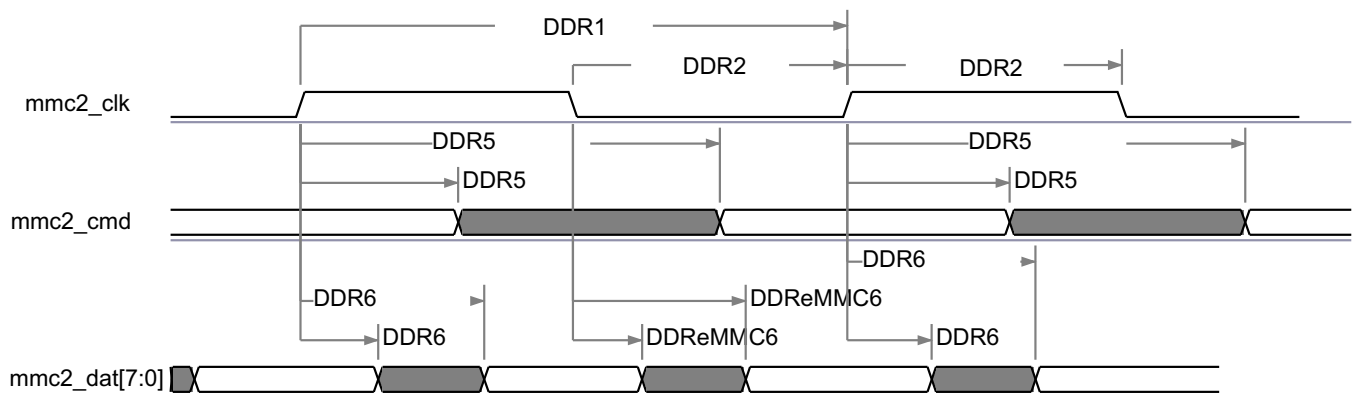

SPRS906\_TIMING\_MMC2\_08

**Figure 5-90. MMC/SD/SDIO in - High Speed DDR JC64 - Transmitter Mode**

**NOTE**

To configure the desired virtual mode the user must set MODESELECT bit and DELAYMODE bitfield for each corresponding pad control register.

The pad control registers are presented in [Table 4-27](#) and described in Device TRM, *Control Module Chapter*.

Virtual IO Timings Modes must be used to ensure some IO timings for MMC2. See [Table 5-28 Modes Summary](#) for a list of IO timings requiring the use of Virtual IO Timings Modes. See [Table 5-132 Virtual Functions Mapping for MMC2](#) for a definition of the Virtual modes.

[Table 5-132](#) presents the values for DELAYMODE bitfield.

**Table 5-132. Virtual Functions Mapping for MMC2**

BALL	BALL NAME	Delay Mode Value	MUXMODE
		MMC2_VIRTUAL2	1
A6	gpmc_cs1	13	mmc2_cmd
A4	gpmc_a19	13	mmc2_dat4

**Table 5-132. Virtual Functions Mapping for MMC2 (continued)**

BALL	BALL NAME	Delay Mode Value	MUXMODE
		MMC2_VIRTUAL2	1
E7	gpmc_a20	13	mmc2_dat5
D6	gpmc_a21	13	mmc2_dat6
C5	gpmc_a22	13	mmc2_dat7
B5	gpmc_a23	13	mmc2_clk
D7	gpmc_a24	13	mmc2_dat0
C6	gpmc_a25	13	mmc2_dat1
A5	gpmc_a26	13	mmc2_dat2
B6	gpmc_a27	13	mmc2_dat3

**NOTE**

To configure the desired Manual IO Timing Mode the user must follow the steps described in section Manual IO Timing Modes of the Device TRM.

The associated registers to configure are listed in the **CFG REGISTER** column. For more information see the Control Module chapter in the Device TRM.

Manual IO Timings Modes must be used to ensure some IO timings for MMC2. See [Table 5-28 Modes Summary](#) for a list of IO timings requiring the use of Manual IO Timings Modes. See [Table 5-133 Manual Functions Mapping for MMC2](#) for a definition of the Manual modes.

[Table 5-133](#) lists the A\_DELAY and G\_DELAY values needed to calculate the correct values to be set in the CFG\_x registers.

**Table 5-133. Manual Functions Mapping for MMC2**

BALL	BALL NAME	MMC2_MANUAL1		MMC2_MANUAL2		MMC2_MANUAL3		CFG REGISTER	MUXMODE
		A_DELAY (ps)	G_DELAY (ps)	A_DELAY (ps)	G_DELAY (ps)	A_DELAY (ps)	G_DELAY (ps)		1
A4	gpmc_a19	0	0	0	14	-	-	CFG_GPMC_A19_IN	mmc2_dat4
E7	gpmc_a20	119	0	127	0	-	-	CFG_GPMC_A20_IN	mmc2_dat5
D6	gpmc_a21	0	0	22	0	-	-	CFG_GPMC_A21_IN	mmc2_dat6
C5	gpmc_a22	18	0	72	0	-	-	CFG_GPMC_A22_IN	mmc2_dat7
B5	gpmc_a23	894	0	410	4000	-	-	CFG_GPMC_A23_IN	mmc2_clk
D7	gpmc_a24	30	0	82	0	-	-	CFG_GPMC_A24_IN	mmc2_dat0
C6	gpmc_a25	0	0	0	0	-	-	CFG_GPMC_A25_IN	mmc2_dat1
A5	gpmc_a26	23	0	77	0	-	-	CFG_GPMC_A26_IN	mmc2_dat2
B6	gpmc_a27	0	0	0	0	-	-	CFG_GPMC_A27_IN	mmc2_dat3
A6	gpmc_cs1	0	0	0	0	-	-	CFG_GPMC_CS1_IN	mmc2_cmd
A4	gpmc_a19	152	0	152	0	285	0	CFG_GPMC_A19_OUT	mmc2_dat4
E7	gpmc_a20	206	0	206	0	189	0	CFG_GPMC_A20_OUT	mmc2_dat5
D6	gpmc_a21	78	0	78	0	0	120	CFG_GPMC_A21_OUT	mmc2_dat6
C5	gpmc_a22	2	0	2	0	0	70	CFG_GPMC_A22_OUT	mmc2_dat7
B5	gpmc_a23	266	0	266	0	730	360	CFG_GPMC_A23_OUT	mmc2_clk
D7	gpmc_a24	0	0	0	0	0	0	CFG_GPMC_A24_OUT	mmc2_dat0
C6	gpmc_a25	0	0	0	0	0	0	CFG_GPMC_A25_OUT	mmc2_dat1
A5	gpmc_a26	43	0	43	0	70	0	CFG_GPMC_A26_OUT	mmc2_dat2
B6	gpmc_a27	0	0	0	0	0	0	CFG_GPMC_A27_OUT	mmc2_dat3
A6	gpmc_cs1	0	0	0	0	0	120	CFG_GPMC_CS1_OUT	mmc2_cmd
A4	gpmc_a19	0	0	0	0	0	0	CFG_GPMC_A19_OEN	mmc2_dat4

**Table 5-133. Manual Functions Mapping for MMC2 (continued)**

BALL	BALL NAME	MMC2_MANUAL1		MMC2_MANUAL2		MMC2_MANUAL3		CFG REGISTER	MUXMODE
		A_DELAY (ps)	G_DELAY (ps)	A_DELAY (ps)	G_DELAY (ps)	A_DELAY (ps)	G_DELAY (ps)		1
E7	gpmc_a20	0	0	0	0	231	0	CFG_GPMC_A20_OEN	mmc2_dat5
D6	gpmc_a21	0	0	0	0	39	0	CFG_GPMC_A21_OEN	mmc2_dat6
C5	gpmc_a22	0	0	0	0	91	0	CFG_GPMC_A22_OEN	mmc2_dat7
D7	gpmc_a24	0	0	0	0	176	0	CFG_GPMC_A24_OEN	mmc2_dat0
C6	gpmc_a25	0	0	0	0	0	0	CFG_GPMC_A25_OEN	mmc2_dat1
A5	gpmc_a26	0	0	0	0	101	0	CFG_GPMC_A26_OEN	mmc2_dat2
B6	gpmc_a27	0	0	0	0	0	0	CFG_GPMC_A27_OEN	mmc2_dat3
A6	gpmc_cs1	0	0	0	0	360	0	CFG_GPMC_CS1_OEN	mmc2_cmd

**5.10.6.20.3 MMC3 and MMC4—SDIO/SD**

MMC3 and MMC4 interfaces are compliant with the SDIO3.0 standard v1.0, SD Part E1 and for generic SDIO devices, it supports the following applications:

- MMC3 8-bit data and MMC4 4-bit data, SD Default speed, SDR
- MMC3 8-bit data and MMC4 4-bit data, SD High speed, SDR
- MMC3 8-bit data and MMC4 4-bit data, UHS-1 SDR12 (SD Standard v3.01), 4-bit data, SDR, half cycle
- MMC3 8-bit data and MMC4 4-bit data, UHS-I SDR25 (SD Standard v3.01), 4-bit data, SDR, half cycle
- MMC3 8-bit data, UHS-I SDR50

**NOTE**

The eMMC/SD/SDIO<sub>j</sub> (j = 3 to 4) controller is also referred to as MMC<sub>j</sub>.

**NOTE**

For more information, see the MMC/SDIO chapter of the Device TRM.

**5.10.6.20.3.1 MMC3 and MMC4, SD Default Speed**

Figure 5-91, Figure 5-92, and Table 5-134 through Table 5-137 present Timing requirements and Switching characteristics for MMC3 and MMC4 - SD Default speed in receiver and transmitter mode.

**Table 5-134. Timing Requirements for MMC3 - Default Speed Mode <sup>(1)</sup>**

NO.	PARAMETER	DESCRIPTION	MIN	MAX	UNIT
DS5	t <sub>su(cmdV-clkH)</sub>	Setup time, mmc3_cmd valid before mmc3_clk rising clock edge	5.11		ns
DS6	t <sub>h(clkH-cmdV)</sub>	Hold time, mmc3_cmd valid after mmc3_clk rising clock edge	20.46		ns
DS7	t <sub>su(dV-clkH)</sub>	Setup time, mmc3_dat[i:0] valid before mmc3_clk rising clock edge	5.11		ns
DS8	t <sub>h(clkH-dV)</sub>	Hold time, mmc3_dat[i:0] valid after mmc3_clk rising clock edge	20.46		ns

(1) i in [i:0] = 7

**Table 5-135. Switching Characteristics for MMC3 - SD/SDIO Default Speed Mode <sup>(2)</sup>**

NO.	PARAMETER	DESCRIPTION	MIN	MAX	UNIT
DS0	fop(clk)	Operating frequency, mmc3_clk		24	MHz
DS1	t <sub>w(clkH)</sub>	Pulse duration, mmc3_clk high	0.5 × P-0.270 <sup>(1)</sup>		ns

**Table 5-135. Switching Characteristics for MMC3 - SD/SDIO Default Speed Mode <sup>(2)</sup> (continued)**

NO.	PARAMETER	DESCRIPTION	MIN	MAX	UNIT
DS2	$t_{w(\text{clkL})}$	Pulse duration, mmc3_clk low	$0.5 \times P - 0.270$ <sup>(1)</sup>		ns
DS3	$t_{d(\text{clkL-cmdV})}$	Delay time, mmc3_clk falling clock edge to mmc3_cmd transition	-14.93	14.93	ns
DS4	$t_{d(\text{clkL-dV})}$	Delay time, mmc3_clk falling clock edge to mmc3_dat[i:0] transition	-14.93	14.93	ns

(1) P = output mmc3\_clk period in ns

(2) i in [i:0] = 7

**Table 5-136. Timing Requirements for MMC4 - Default Speed Mode <sup>(1)</sup>**

NO.	PARAMETER	DESCRIPTION	MIN	MAX	UNIT
DS5	$t_{su(\text{cmdV-clkH})}$	Setup time, mmc4_cmd valid before mmc4_clk rising clock edge	5.11		ns
DS6	$t_{h(\text{clkH-cmdV})}$	Hold time, mmc4_cmd valid after mmc4_clk rising clock edge	20.46		ns
DS7	$t_{su(\text{dV-clkH})}$	Setup time, mmc4_dat[i:0] valid before mmc4_clk rising clock edge	5.11		ns
DS8	$t_{h(\text{clkH-dV})}$	Hold time, mmc4_dat[i:0] valid after mmc4_clk rising clock edge	20.46		ns

(1) i in [i:0] = 3

**Table 5-137. Switching Characteristics for MMC4 - Default Speed Mode <sup>(2)</sup>**

NO.	PARAMETER	DESCRIPTION	MIN	MAX	UNIT
DS0	fop(clk)	Operating frequency, mmc4_clk		24	MHz
DS1	$t_{w(\text{clkH})}$	Pulse duration, mmc4_clk high	$0.5 \times P - 0.270$ <sup>(1)</sup>		ns
DS2	$t_{w(\text{clkL})}$	Pulse duration, mmc4_clk low	$0.5 \times P - 0.270$ <sup>(1)</sup>		ns
DS3	$t_{d(\text{clkL-cmdV})}$	Delay time, mmc4_clk falling clock edge to mmc4_cmd transition	-14.93	14.93	ns
DS4	$t_{d(\text{clkL-dV})}$	Delay time, mmc4_clk falling clock edge to mmc4_dat[i:0] transition	-14.93	14.93	ns

(1) P = output mmc4\_clk period in ns

(2) i in [i:0] = 3

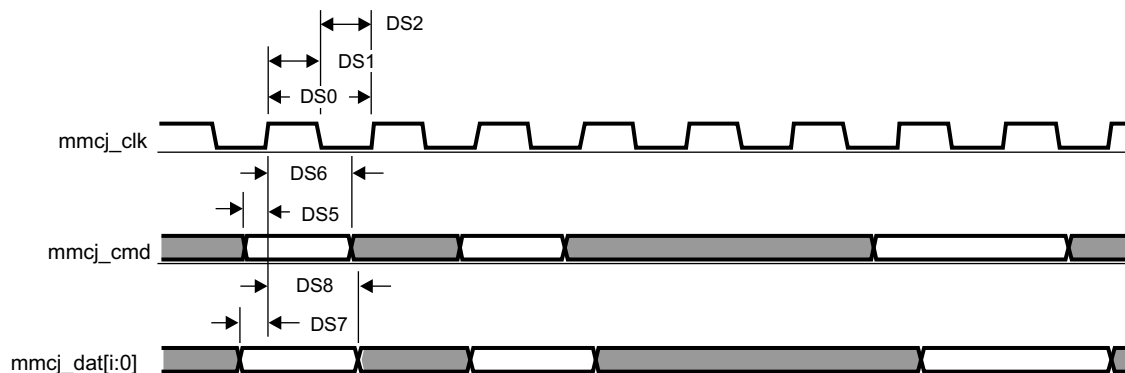

SPRS906\_TIMING\_MMC3\_07

**Figure 5-91. MMC/SD/SDIOj in - Default Speed - Receiver Mode**

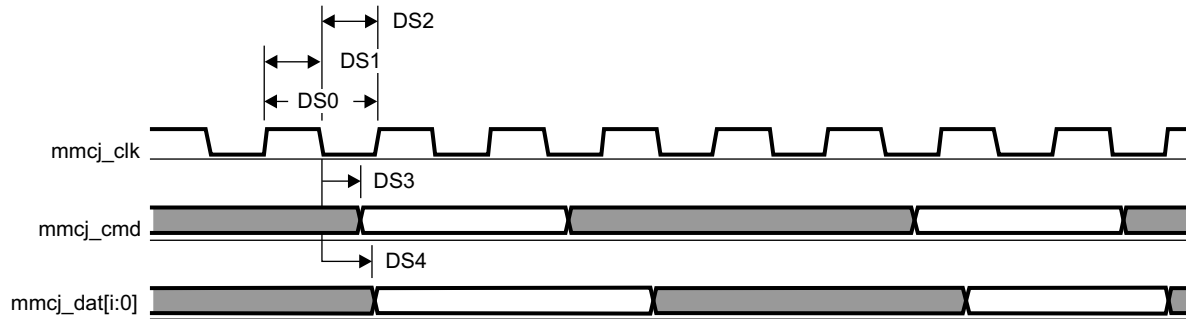

SPRS906\_TIMING\_MMC3\_08

**Figure 5-92. MMC/SD/SDIOj in - Default Speed - Transmitter Mode**

### 5.10.6.20.3.2 MMC3 and MMC4, SD High Speed

Figure 5-93, Figure 5-94, and Table 5-138 through Table 5-141 present Timing requirements and Switching characteristics for MMC3 and MMC4 - SD and SDIO High speed in receiver and transmitter mode.

**Table 5-138. Timing Requirements for MMC3 - SD/SDIO High Speed Mode <sup>(1)</sup>**

NO.	PARAMETER	DESCRIPTION	MIN	MAX	UNIT
HS3	$t_{su(cmdV-clkH)}$	Setup time, mmc3_cmd valid before mmc3_clk rising clock edge	5.3		ns
HS4	$t_{h(clkH-cmdV)}$	Hold time, mmc3_cmd valid after mmc3_clk rising clock edge	2.6		ns
HS7	$t_{su(dV-clkH)}$	Setup time, mmc3_dat[i:0] valid before mmc3_clk rising clock edge	5.3		ns
HS8	$t_{h(clkH-dV)}$	Hold time, mmc3_dat[i:0] valid after mmc3_clk rising clock edge	2.6		ns

(1) i in [i:0] = 7

**Table 5-139. Switching Characteristics for MMC3 - SD/SDIO High Speed Mode <sup>(2)</sup>**

NO.	PARAMETER	DESCRIPTION	MIN	MAX	UNIT
HS1	fop(clk)	Operating frequency, mmc3_clk		48	MHz
HS2H	$t_w(clkH)$	Pulse duration, mmc3_clk high	$0.5 \times P - 0.270$ <sup>(1)</sup>		ns
HS2L	$t_w(clkL)$	Pulse duration, mmc3_clk low	$0.5 \times P - 0.270$ <sup>(1)</sup>		ns
HS5	$t_d(clkL-cmdV)$	Delay time, mmc3_clk falling clock edge to mmc3_cmd transition	-7.6	3.6	ns
HS6	$t_d(clkL-dV)$	Delay time, mmc3_clk falling clock edge to mmc3_dat[i:0] transition	-7.6	3.6	ns

(1) P = output mmc3\_clk period in ns

(2) i in [i:0] = 7

**Table 5-140. Timing Requirements for MMC4 - High Speed Mode <sup>(1)</sup>**

NO.	PARAMETER	DESCRIPTION	MIN	MAX	UNIT
HS3	$t_{su(cmdV-clkH)}$	Setup time, mmc4_cmd valid before mmc4_clk rising clock edge	5.3		ns
HS4	$t_{h(clkH-cmdV)}$	Hold time, mmc4_cmd valid after mmc4_clk rising clock edge	1.6		ns
HS7	$t_{su(dV-clkH)}$	Setup time, mmc4_dat[i:0] valid before mmc4_clk rising clock edge	5.3		ns
HS8	$t_{h(clkH-dV)}$	Hold time, mmc4_dat[i:0] valid after mmc4_clk rising clock edge	1.6		ns

(1) i in [i:0] = 3

**Table 5-141. Switching Characteristics for MMC4 - High Speed Mode <sup>(2)</sup>**

NO.	PARAMETER	DESCRIPTION	MIN	MAX	UNIT
HS1	fop(clk)	Operating frequency, mmc4_clk		48	MHz
HS2H	$t_w(clkH)$	Pulse duration, mmc4_clk high	$0.5 \times P - 0.270$ <sup>(1)</sup>		ns

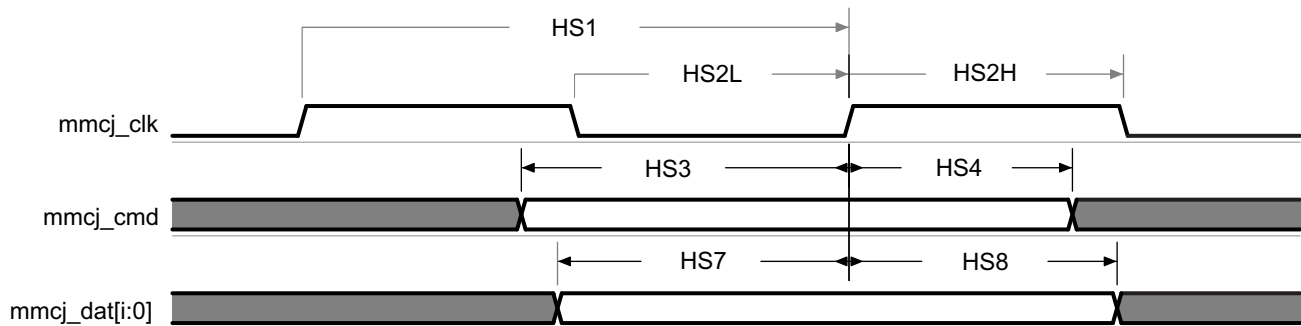

**Table 5-141. Switching Characteristics for MMC4 - High Speed Mode <sup>(2)</sup> (continued)**

NO.	PARAMETER	DESCRIPTION	MIN	MAX	UNIT
HS2L	$t_{w(\text{clkL})}$	Pulse duration, mmc4_clk low	$0.5 \times P - 0.270$ <sup>(1)</sup>		ns
HS5	$t_{d(\text{clkL-cmdV})}$	Delay time, mmc4_clk falling clock edge to mmc4_cmd transition	-8.8	6.6	ns
HS6	$t_{d(\text{clkL-dV})}$	Delay time, mmc4_clk falling clock edge to mmc4_dat[i:0] transition	-8.8	6.6	ns

(1) P = output mmc4\_clk period in ns

(2) i in [i:0] = 3



SPRS906\_TIMING\_MMC3\_09

**Figure 5-93. MMC/SD/SDIOj in - High Speed 3.3V Signaling - Receiver Mode**

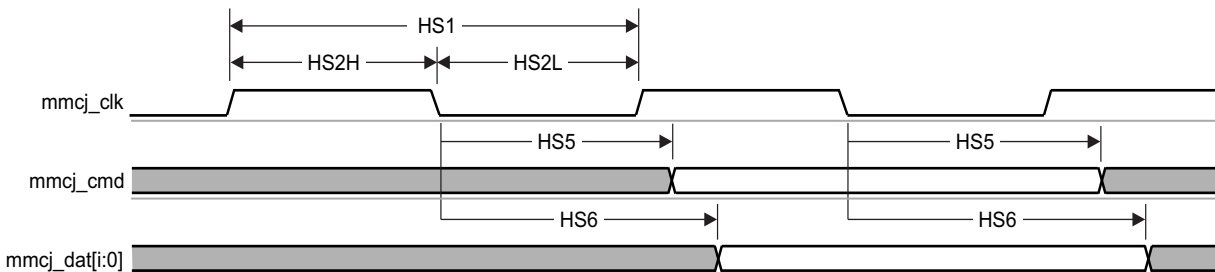

SPRS906\_TIMING\_MMC3\_10

**Figure 5-94. MMC/SD/SDIOj in - High Speed 3.3V Signaling - Transmitter Mode**

**5.10.6.20.3.3 MMC3 and MMC4, SD and SDIO SDR12 Mode**

Figure 5-95, Figure 5-96, and Table 5-142, through Table 5-145 present Timing requirements and Switching characteristics for MMC3 and MMC4 - SD and SDIO SDR12 in receiver and transmitter mode.

**Table 5-142. Timing Requirements for MMC3 - SDR12 Mode <sup>(1)</sup>**

NO.	PARAMETER	DESCRIPTION	MIN	MAX	UNIT
SDR125	$t_{su(\text{cmdV-clkH})}$	Setup time, mmc3_cmd valid before mmc3_clk rising clock edge	25.99		ns
SDR126	$t_{h(\text{clkH-cmdV})}$	Hold time, mmc3_cmd valid after mmc3_clk rising clock edge	1.6		ns
SDR127	$t_{su(\text{dV-clkH})}$	Setup time, mmc3_dat[i:0] valid before mmc3_clk rising clock edge	25.99		ns
SDR128	$t_{h(\text{clkH-dV})}$	Hold time, mmc3_dat[i:0] valid after mmc3_clk rising clock edge	1.6		ns

(1) i in [i:0] = 7

**Table 5-143. Switching Characteristics for MMC3 - SDR12 Mode <sup>(2)</sup>**

NO.	PARAMETER	DESCRIPTION	MIN	MAX	UNIT
SDR120	fop(clk)	Operating frequency, mmc3_clk		24	MHz
SDR121	$t_{w(\text{clkH})}$	Pulse duration, mmc3_clk high	$0.5 \times P - 0.270$ <sup>(1)</sup>		ns

**Table 5-143. Switching Characteristics for MMC3 - SDR12 Mode <sup>(2)</sup> (continued)**

NO.	PARAMETER	DESCRIPTION	MIN	MAX	UNIT
SDR122	$t_{w(\text{clkL})}$	Pulse duration, mmc3_clk low	$0.5 \times P - 0.270$ <sup>(1)</sup>		ns
SDR123	$t_{d(\text{clkL-cmdV})}$	Delay time, mmc3_clk falling clock edge to mmc3_cmd transition	-19.13	16.93	ns
SDR124	$t_{d(\text{clkL-dV})}$	Delay time, mmc3_clk falling clock edge to mmc3_dat[i:0] transition	-19.13	16.93	ns

(1) P = output mmc3\_clk period in ns

(2) i in [i:0] = 7

**Table 5-144. Timing Requirements for MMC4 - SDR12 Mode <sup>(1)</sup>**

NO.	PARAMETER	DESCRIPTION	MIN	MAX	UNIT
SDR125	$t_{su(\text{cmdV-clkH})}$	Setup time, mmc4_cmd valid before mmc4_clk rising clock edge	25.99		ns
SDR126	$t_{h(\text{clkH-cmdV})}$	Hold time, mmc4_cmd valid after mmc4_clk rising clock edge	1.6		ns
SDR127	$t_{su(\text{dV-clkH})}$	Setup time, mmc4_dat[i:0] valid before mmc4_clk rising clock edge	25.99		ns
SDR128	$t_{h(\text{clkH-dV})}$	Hold time, mmc4_dat[i:0] valid after mmc4_clk rising clock edge	1.6		ns

(1) j in [i:0] = 3

**Table 5-145. Switching Characteristics for MMC4 - SDR12 Mode <sup>(2)</sup>**

NO.	PARAMETER	DESCRIPTION	MIN	MAX	UNIT
SDR120	fop(clk)	Operating frequency, mmc4_clk		24	MHz
SDR121	$t_{w(\text{clkH})}$	Pulse duration, mmc4_clk high	$0.5 \times P - 0.270$ <sup>(1)</sup>		ns
SDR122	$t_{w(\text{clkL})}$	Pulse duration, mmc4_clk low	$0.5 \times P - 0.270$ <sup>(1)</sup>		ns
SDR125	$t_{d(\text{clkL-cmdV})}$	Delay time, mmc4_clk falling clock edge to mmc4_cmd transition	-19.13	16.93	ns
SDR126	$t_{d(\text{clkL-dV})}$	Delay time, mmc4_clk falling clock edge to mmc4_dat[i:0] transition	-19.13	16.93	ns

(1) P = output mmc4\_clk period in ns

(2) j in [i:0] = 3

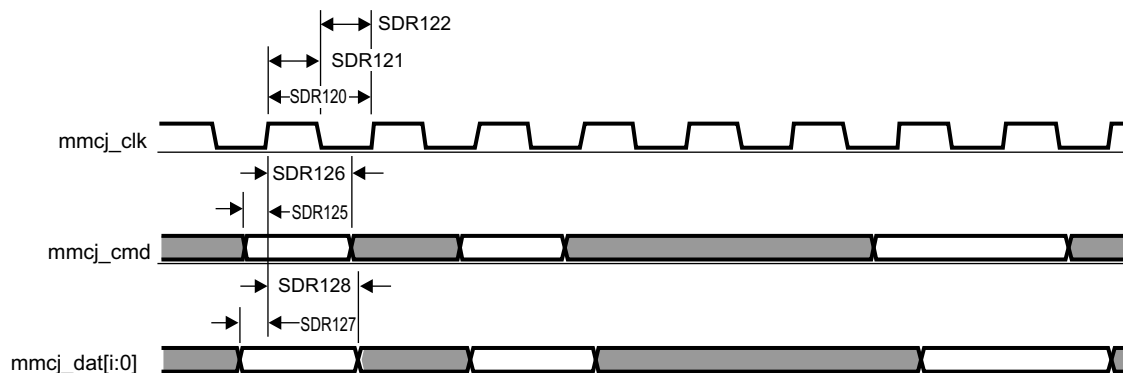

SPRS906\_TIMING\_MMC3\_11

**Figure 5-95. MMC/SD/SDIOj in - SDR12 - Receiver Mode**

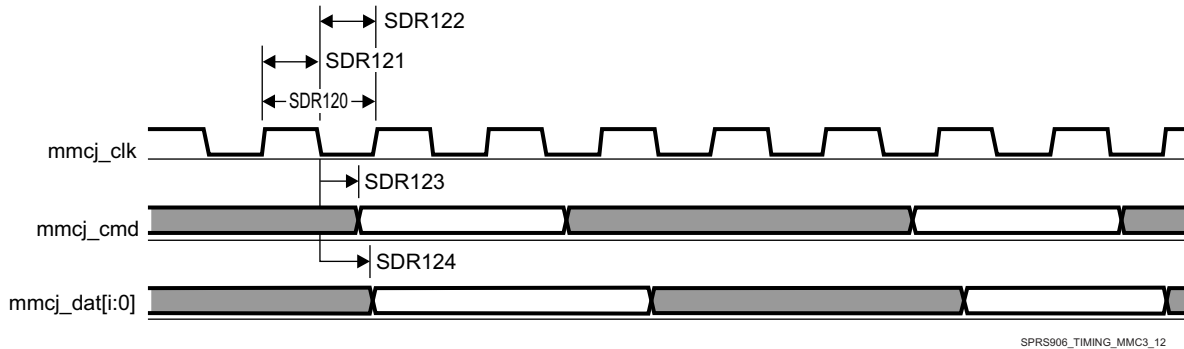

Figure 5-96. MMC/SD/SDIOj in - SDR12 - Transmitter Mode

5.10.6.20.3.4 MMC3 and MMC4, SD SDR25 Mode

Figure 5-97, Figure 5-98, and Table 5-146, through Table 5-149 present Timing requirements and Switching characteristics for MMC3 and MMC4 - SD and SDIO SDR25 in receiver and transmitter mode.

Table 5-146. Timing Requirements for MMC3 - SDR25 Mode <sup>(1)</sup>

NO.	PARAMETER	DESCRIPTION	MIN	MAX	UNIT
SDR253	$t_{su}(cmdV-clkH)$	Setup time, mmc3_cmd valid before mmc3_clk rising clock edge	5.3		ns
SDR254	$t_h(clkH-cmdV)$	Hold time, mmc3_cmd valid after mmc3_clk rising clock edge	1.6		ns
SDR257	$t_{su}(dV-clkH)$	Setup time, mmc3_dat[i:0] valid before mmc3_clk rising clock edge	5.3		ns
SDR258	$t_h(clkH-dV)$	Hold time, mmc3_dat[i:0] valid after mmc3_clk rising clock edge	1.6		ns

(1) i in [i:0] = 7

Table 5-147. Switching Characteristics for MMC3 - SDR25 Mode <sup>(2)</sup>

NO.	PARAMETER	DESCRIPTION	MIN	MAX	UNIT
SDR251	fop(clk)	Operating frequency, mmc3_clk		48	MHz
SDR252 H	$t_w(clkH)$	Pulse duration, mmc3_clk high	0.5 × P-0.270 <sup>(1)</sup>		ns
SDR252L	$t_w(clkL)$	Pulse duration, mmc3_clk low	0.5 × P-0.270 <sup>(1)</sup>		ns
SDR255	$t_d(clkL-cmdV)$	Delay time, mmc3_clk falling clock edge to mmc3_cmd transition	-8.8	6.6	ns
SDR256	$t_d(clkL-dV)$	Delay time, mmc3_clk falling clock edge to mmc3_dat[i:0] transition	-8.8	6.6	ns

(1) P = output mmc3\_clk period in ns

(2) i in [i:0] = 7

Table 5-148. Timing Requirements for MMC4 - SDR25 Mode <sup>(1)</sup>

NO.	PARAMETER	DESCRIPTION	MIN	MAX	UNIT
SDR255	$t_{su}(cmdV-clkH)$	Setup time, mmc4_cmd valid before mmc4_clk rising clock edge	5.3		ns
SDR256	$t_h(clkH-cmdV)$	Hold time, mmc4_cmd valid after mmc4_clk rising clock edge	1.6		ns
SDR257	$t_{su}(dV-clkH)$	Setup time, mmc4_dat[i:0] valid before mmc4_clk rising clock edge	5.3		ns
SDR258	$t_h(clkH-dV)$	Hold time, mmc4_dat[i:0] valid after mmc4_clk rising clock edge	1.6		ns

(1) i in [i:0] = 3

Table 5-149. Switching Characteristics for MMC4 - SDR25 Mode <sup>(2)</sup>

NO.	PARAMETER	DESCRIPTION	MIN	MAX	UNIT
SDR251	fop(clk)	Operating frequency, mmc4_clk		48	MHz
SDR252 H	$t_w(clkH)$	Pulse duration, mmc4_clk high	0.5 × P-0.270 <sup>(1)</sup>		ns

Table 5-149. Switching Characteristics for MMC4 - SDR25 Mode <sup>(2)</sup> (continued)

NO.	PARAMETER	DESCRIPTION	MIN	MAX	UNIT
SDR252L	$t_{w(\text{clkL})}$	Pulse duration, mmc4_clk low	$0.5 \times P - 0.270$ <sup>(1)</sup>		ns
SDR255	$t_{d(\text{clkL-cmdV})}$	Delay time, mmc4_clk falling clock edge to mmc4_cmd transition	-8.8	6.6	ns
SDR256	$t_{d(\text{clkL-dV})}$	Delay time, mmc4_clk falling clock edge to mmc4_dat[i:0] transition	-8.8	6.6	ns

(1) P = output mmc4\_clk period in ns

(2) i in [i:0] = 3

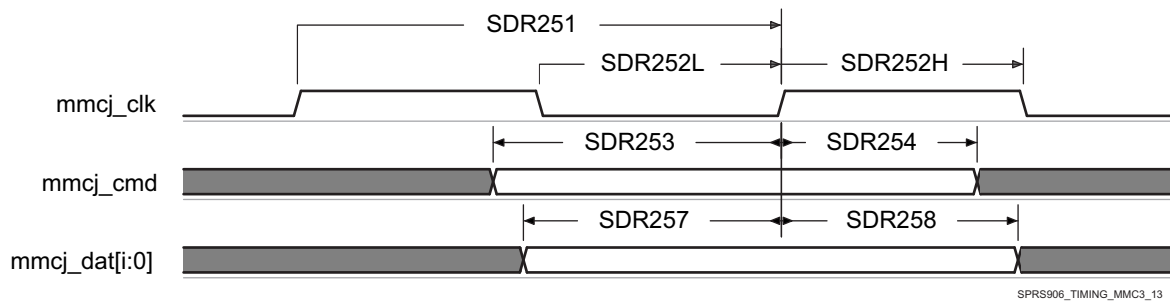

Figure 5-97. MMC/SD/SDIOj in - SDR25 - Receiver Mode

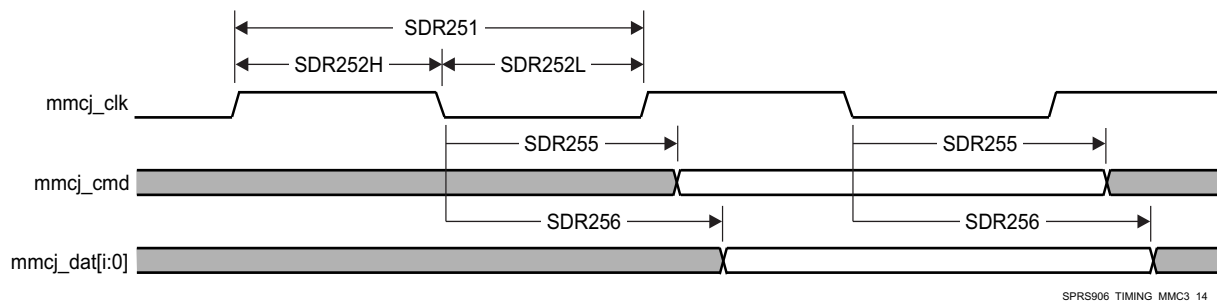

Figure 5-98. MMC/SD/SDIOj in - SDR25 - Transmitter Mode

### 5.10.6.20.3.5 MMC3 SDIO High-Speed UHS-I SDR50 Mode, Half Cycle

Figure 5-99, Figure 5-100, Table 5-150, and Table 5-151 present Timing requirements and Switching characteristics for MMC3 - SDIO High speed SDR50 in receiver and transmitter mode.

Table 5-150. Timing Requirements for MMC3 - SDR50 Mode <sup>(1)</sup>

NO.	PARAMETER	DESCRIPTION	MIN	MAX	UNIT
SDR503	$t_{su(\text{cmdV-clkH})}$	Setup time, mmc3_cmd valid before mmc3_clk rising clock edge	1.48		ns
SDR504	$t_{h(\text{clkH-cmdV})}$	Hold time, mmc3_cmd valid after mmc3_clk rising clock edge	1.6		ns
SDR507	$t_{su(\text{dV-clkH})}$	Setup time, mmc3_dat[i:0] valid before mmc3_clk rising clock edge	1.48		ns
SDR508	$t_{h(\text{clkH-dV})}$	Hold time, mmc3_dat[i:0] valid after mmc3_clk rising clock edge	1.6		ns

(1) i in [i:0] = 7

Table 5-151. Switching Characteristics for MMC3 - SDR50 Mode <sup>(2)</sup>

NO.	PARAMETER	DESCRIPTION	MIN	MAX	UNIT
SDR501	fop(clk)	Operating frequency, mmc3_clk		64	MHz
SDR502H	$t_{w(\text{clkH})}$	Pulse duration, mmc3_clk high	$0.5 \times P - 0.270$ <sup>(1)</sup>		ns
SDR502L	$t_{w(\text{clkL})}$	Pulse duration, mmc3_clk low	$0.5 \times P - 0.270$ <sup>(1)</sup>		ns

**Table 5-151. Switching Characteristics for MMC3 - SDR50 Mode <sup>(2)</sup> (continued)**

NO.	PARAMETER	DESCRIPTION	MIN	MAX	UNIT
SDR505	$t_{d(\text{clkL-cmdV})}$	Delay time, mmc3_clk falling clock edge to mmc3_cmd transition	-3.66	1.46	ns
SDR506	$t_{d(\text{clkL-dV})}$	Delay time, mmc3_clk falling clock edge to mmc3_dat[i:0] transition	-3.66	1.46	ns

(1) P = output mmc3\_clk period in ns

(2) i in [i:0] = 7

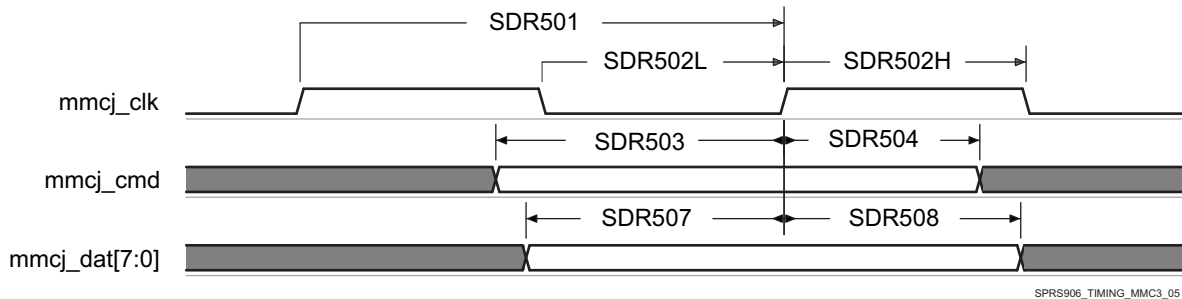

**Figure 5-99. MMC/SD/SDIOj in - High Speed SDR50 - Receiver Mode**

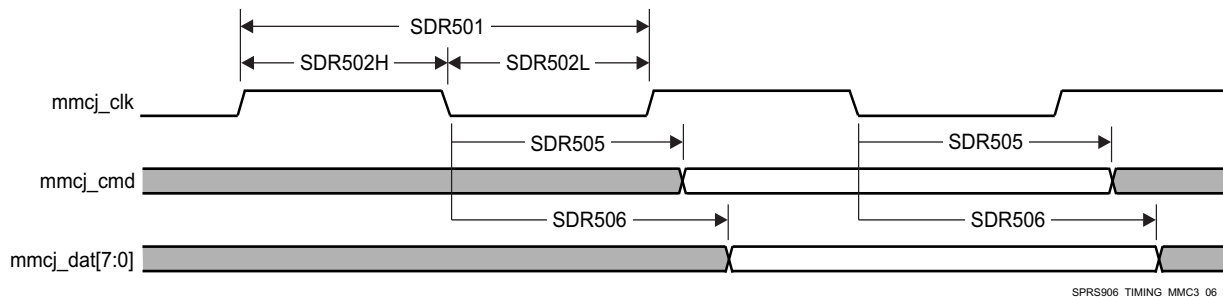

**Figure 5-100. MMC/SD/SDIOj in - High Speed SDR50 - Transmitter Mode**

**NOTE**

To configure the desired Manual IO Timing Mode the user must follow the steps described in section Manual IO Timing Modes of the Device TRM.

The associated registers to configure are listed in the **CFG REGISTER** column. For more information see the Control Module chapter in the Device TRM.

Manual IO Timings Modes must be used to ensure some IO timings for MMC3. See [Table 5-28 Modes Summary](#) for a list of IO timings requiring the use of Manual IO Timings Modes. See [Table 5-152 Manual Functions Mapping for MMC3](#) for a definition of the Manual modes.

[Table 5-152](#) lists the A\_DELAY and G\_DELAY values needed to calculate the correct values to be set in the CFG\_x registers.

**Table 5-152. Manual Functions Mapping for MMC3**

BALL	BALL NAME	MMC3_MANUAL1		CFG REGISTER	MUXMODE
		A_DELAY (ps)	G_DELAY (ps)		0
Y2	mmc3_clk	1085	21	CFG_MMC3_CLK_IN	mmc3_clk
Y2	mmc3_clk	1269	0	CFG_MMC3_CLK_OUT	mmc3_clk
Y1	mmc3_cmd	0	0	CFG_MMC3_CMD_IN	mmc3_cmd
Y1	mmc3_cmd	128	0	CFG_MMC3_CMD_OEN	mmc3_cmd
Y1	mmc3_cmd	98	0	CFG_MMC3_CMD_OUT	mmc3_cmd
Y4	mmc3_dat0	0	0	CFG_MMC3_DAT0_IN	mmc3_dat0

**Table 5-152. Manual Functions Mapping for MMC3 (continued)**

BALL	BALL NAME	MMC3_MANUAL1		CFG REGISTER	MUXMODE
		A_DELAY (ps)	G_DELAY (ps)		0
Y4	mmc3_dat0	362	0	CFG_MMC3_DAT0_OEN	mmc3_dat0
Y4	mmc3_dat0	0	0	CFG_MMC3_DAT0_OUT	mmc3_dat0
AA2	mmc3_dat1	7	0	CFG_MMC3_DAT1_IN	mmc3_dat1
AA2	mmc3_dat1	333	0	CFG_MMC3_DAT1_OEN	mmc3_dat1
AA2	mmc3_dat1	0	0	CFG_MMC3_DAT1_OUT	mmc3_dat1
AA3	mmc3_dat2	0	0	CFG_MMC3_DAT2_IN	mmc3_dat2
AA3	mmc3_dat2	402	0	CFG_MMC3_DAT2_OEN	mmc3_dat2
AA3	mmc3_dat2	0	0	CFG_MMC3_DAT2_OUT	mmc3_dat2
W2	mmc3_dat3	203	0	CFG_MMC3_DAT3_IN	mmc3_dat3
W2	mmc3_dat3	549	0	CFG_MMC3_DAT3_OEN	mmc3_dat3
W2	mmc3_dat3	1	0	CFG_MMC3_DAT3_OUT	mmc3_dat3
Y3	mmc3_dat4	121	0	CFG_MMC3_DAT4_IN	mmc3_dat4
Y3	mmc3_dat4	440	0	CFG_MMC3_DAT4_OEN	mmc3_dat4
Y3	mmc3_dat4	206	0	CFG_MMC3_DAT4_OUT	mmc3_dat4
AA1	mmc3_dat5	336	0	CFG_MMC3_DAT5_IN	mmc3_dat5
AA1	mmc3_dat5	283	0	CFG_MMC3_DAT5_OEN	mmc3_dat5
AA1	mmc3_dat5	174	0	CFG_MMC3_DAT5_OUT	mmc3_dat5
AA4	mmc3_dat6	320	0	CFG_MMC3_DAT6_IN	mmc3_dat6
AA4	mmc3_dat6	443	0	CFG_MMC3_DAT6_OEN	mmc3_dat6
AA4	mmc3_dat6	0	0	CFG_MMC3_DAT6_OUT	mmc3_dat6
AB1	mmc3_dat7	2	0	CFG_MMC3_DAT7_IN	mmc3_dat7
AB1	mmc3_dat7	344	0	CFG_MMC3_DAT7_OEN	mmc3_dat7
AB1	mmc3_dat7	0	0	CFG_MMC3_DAT7_OUT	mmc3_dat7

#### 5.10.6.21 GPIO

The general-purpose interface combines eight general-purpose input/output (GPIO) banks. Each GPIO module provides up to 32 dedicated general-purpose pins with input and output capabilities; thus, the general-purpose interface supports up to 186 pins.

These pins can be configured for the following applications:

- Data input (capture)/output (drive)
- Keyboard interface with a debounce cell
- Interrupt generation in active mode upon the detection of external events. Detected events are processed by two parallel independent interrupt-generation submodules to support biprocessor operations
- Wake-up request generation in idle mode upon the detection of external events

---

#### NOTE

For more information, see the General-Purpose Interface chapter of the Device TRM.

---



---

#### NOTE

The general-purpose input/output *i* (*i* = 1 to 8) bank is also referred to as GPIO<sub>*i*</sub>.

---

#### 5.10.6.22 System and Miscellaneous interfaces

The Device includes the following System and Miscellaneous interfaces:

- Sysboot Interface
- System DMA Interface
- Interrupt Controllers (INTC) Interface

### 5.10.7 Emulation and Debug Subsystem

The Device includes the following Test interfaces:

- IEEE 1149.1 Standard-Test-Access Port (JTAG)
- Trace Port Interface Unit (TPIU)

#### 5.10.7.1 IEEE 1149.1 Standard-Test-Access Port (JTAG)

The JTAG (IEEE Standard 1149.1-1990 Standard-Test-Access Port and Boundary Scan Architecture) interface is used for BSDL testing and emulation of the device. The *trstn* pin only needs to be released when it is necessary to use a JTAG controller to debug the device or exercise the device's boundary scan functionality. For maximum reliability, the device includes an internal Pulldown (IPD) on the *trstn* pin to ensure that *trstn* is always asserted upon power up and the device's internal emulation logic is always properly initialized. JTAG controllers from Texas Instruments actively drive *trstn* high. However, some third-party JTAG controllers may not drive *trstn* high but expect the use of a Pullup resistor on *trstn*. When using this type of JTAG controller, assert *trstn* to initialize the device after powerup and externally drive *trstn* high before attempting any emulation or boundary-scan operations.

The main JTAG features include:

- 32KB embedded trace buffer (ETB)
- 5-pin system trace interface for debug
- Supports Advanced Event Triggering (AET)
- All processors can be emulated via JTAG ports
- All functions on EMU pins of the device:
  - EMU[1:0] - cross-triggering, boot mode (WIR), STM trace
  - EMU[4:2] - STM trace only (single direction)

##### 5.10.7.1.1 JTAG Electrical Data/Timing

Table 5-153, Table 5-154 and Figure 5-101 assume testing over the recommended operating conditions and electrical characteristic conditions below.

**Table 5-153. Timing Requirements for IEEE 1149.1 JTAG**

NO.	PARAMETER	DESCRIPTION	MIN	MAX	UNIT
1	$t_c(\text{TCK})$	Cycle time, TCK	62.29		ns
1a	$t_w(\text{TCKH})$	Pulse duration, TCK high (40% of $t_c$ )	24.92		ns
1b	$t_w(\text{TCKL})$	Pulse duration, TCK low (40% of $t_c$ )	24.92		ns
3	$t_{su}(\text{TDI-TCK})$	Input setup time, TDI valid to TCK high	6.23		ns
	$t_{su}(\text{TMS-TCK})$	Input setup time, TMS valid to TCK high	6.23		ns
4	$t_h(\text{TCK-TDI})$	Input hold time, TDI valid from TCK high	31.15		ns
	$t_h(\text{TCK-TMS})$	Input hold time, TMS valid from TCK high	31.15		ns

**Table 5-154. Switching Characteristics Over Recommended Operating Conditions for IEEE 1149.1 JTAG**

NO.	PARAMETER	DESCRIPTION	MIN	MAX	UNIT
2	$t_d(\text{TCKL-TDOV})$	Delay time, TCK low to TDO valid	0	30.5	ns

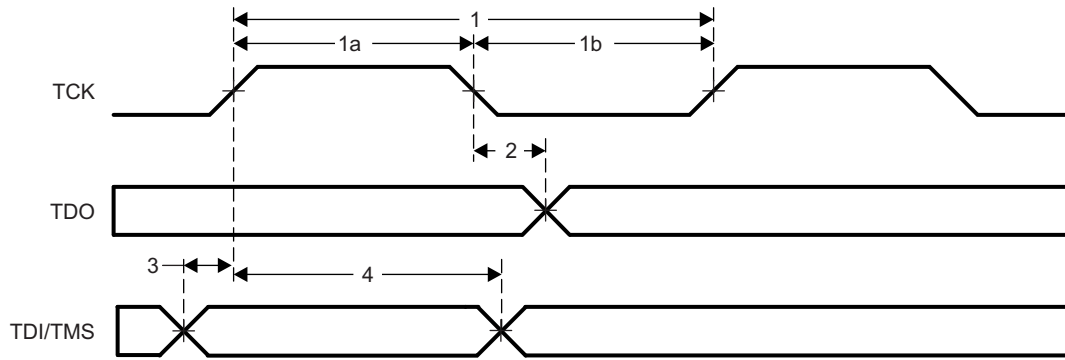

SPRS906\_TIMING\_JTAG\_01

Figure 5-101. JTAG Timing

Table 5-155, Table 5-156 and Figure 5-102 assume testing over the recommended operating conditions and electrical characteristic conditions below.

Table 5-155. Timing Requirements for IEEE 1149.1 JTAG With RTCK

NO.	PARAMETER	DESCRIPTION	MIN	MAX	UNIT
1	$t_c(\text{TCK})$	Cycle time, TCK	62.29		ns
1a	$t_w(\text{TCKH})$	Pulse duration, TCK high (40% of $t_c$ )	24.92		ns
1b	$t_w(\text{TCKL})$	Pulse duration, TCK low (40% of $t_c$ )	24.92		ns
3	$t_{su}(\text{TDI-TCK})$	Input setup time, TDI valid to TCK high	6.23		ns
	$t_{su}(\text{TMS-TCK})$	Input setup time, TMS valid to TCK high	6.23		ns
4	$t_h(\text{TCK-TDI})$	Input hold time, TDI valid from TCK high	31.15		ns
	$t_h(\text{TCK-TMS})$	Input hold time, TMS valid from TCK high	31.15		ns

Table 5-156. Switching Characteristics Over Recommended Operating Conditions for IEEE 1149.1 JTAG With RTCK

NO.	PARAMETER	DESCRIPTION	MIN	MAX	UNIT
5	$t_d(\text{TCK-RTCK})$	Delay time, TCK to RTCK with no selected subpaths (i.e. ICEPick is the only tap selected - when the Arm is in the scan chain, the delay time is a function of the Arm functional clock).	0	27	ns
6	$t_c(\text{RTCK})$	Cycle time, RTCK	62.29		ns
7	$t_w(\text{RTCKH})$	Pulse duration, RTCK high (40% of $t_c$ )	24.92		ns
8	$t_w(\text{RTCKL})$	Pulse duration, RTCK low (40% of $t_c$ )	24.92		ns

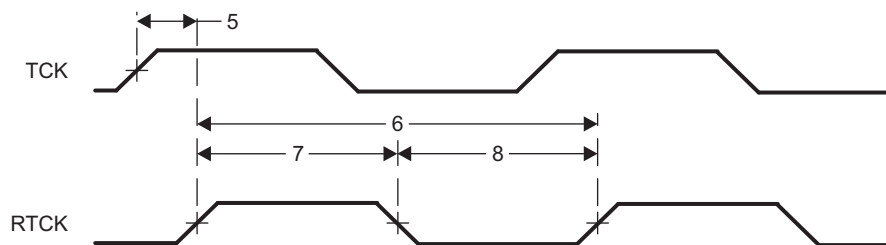

SPRS906\_TIMING\_JTAG\_02

Figure 5-102. JTAG With RTCK Timing



5.10.7.2 Trace Port Interface Unit (TPIU)

**CAUTION**

The I/O timings provided in this section are valid only if signals within a single IOSET are used. The IOSETs are defined in [Table 5-158](#).

5.10.7.2.1 TPIU PLL DDR Mode

[Table 5-157](#) and [Figure 5-103](#) assume testing over the recommended operating conditions and electrical characteristic conditions below.

**Table 5-157. Switching Characteristics for TPIU**

NO.	PARAMETER	DESCRIPTION	MIN	MAX	UNIT
TPIU1	$t_{c(\text{clk})}$	Cycle time, TRACECLK period	5.56		ns
TPIU4	$t_{d(\text{clk-cltV})}$	Skew time, TRACECLK transition to TRACECTL transition	-1.61	1.98	ns
TPIU5	$t_{d(\text{clk-dataV})}$	Skew time, TRACECLK transition to TRACEDATA[17:0]	-1.61	1.98	ns

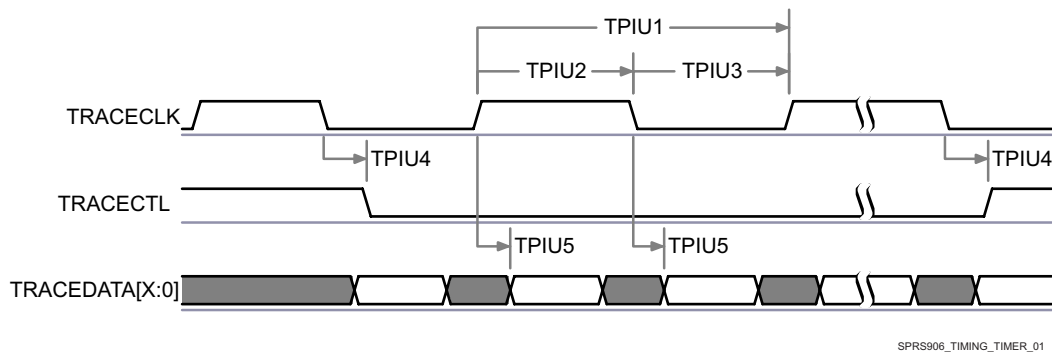

**Figure 5-103. TPIU—PLL DDR Transmit Mode<sup>(1)</sup>**

(1) In d[X:0], X is equal to 15 or 17.

In [Table 5-158](#) are presented the specific groupings of signals (IOSET) for use with TPIU signals.

**Table 5-158. TPIU IOSETs**

SIGNALS	IOSET1		IOSET2	
	BALL	MUX	BALL	MUX
emu19	E10	5		
emu18	B10	5		
emu17	A10	5		
emu16	F10	5		
emu15	A11	5		
emu14	A8	5		
emu13	A9	5		
emu12	A7	5		
emu11	B9	5		
emu10	C8	5		
emu9	B8	5		
emu8	E8	5		
emu7	C7	5		
emu6	B7	5		

Table 5-158. TPIU IOSETs (continued)

SIGNALS	IOSET1		IOSET2	
	BALL	MUX	BALL	MUX
emu5	D8	5		
emu1	C22	0	C22	0
emu0	C21	0	C21	0

## 6 Detailed Description

### 6.1 Description

TI's new TDA2Ex System-on-Chip (SoC) is a highly optimized and scalable family of devices designed to meet the requirements of leading Advanced Driver Assistance Systems (ADAS). The TDA2Ex family enables broad ADAS applications in today's automobile by integrating an optimal mix of performance, low power, and ADAS vision analytics processing that aims to facilitate a more autonomous and collision-free driving experience.

The TDA2Ex SoC enables sophisticated embedded vision technology in today's automobile by enabling a board range of ADAS applications including park assist, surround view and sensor fusion on a single architecture.

The TDA2Ex SoC incorporates a heterogeneous, scalable architecture that includes a mix of TI's fixed and floating-point TMS320C66x digital signal processor (DSP) generation core, Arm Cortex-A15 MPCore and dual-Cortex-M4 processors. The integration of a video accelerator for decoding multiple video streams over an Ethernet AVB network, along with graphics accelerator for rendering virtual views, enable a 3D viewing experience. The TDA2Ex SoC also integrates a host of peripherals including multicamera interfaces (both parallel and serial, including CSI-2) to enable Ethernet or LVDS-based surround view systems, displays and GigB Ethernet AVB.

Additionally, TI provides a complete set of development tools for the Arm and DSP, including C compilers, a DSP assembly optimizer to simplify programming and scheduling, and a debugging interface for visibility into source code execution.

Cryptographic acceleration is available in all devices. All other supported security features, including support for secure boot, debug security and support for trusted execution environment are available on High-Security (HS) devices. For more information about HS devices, contact your TI representative.

The TDA2Ex ADAS processor is qualified according to the AEC-Q100 standard.

### 6.2 Functional Block Diagram

[Figure 6-1](#) is functional block diagram for the device.

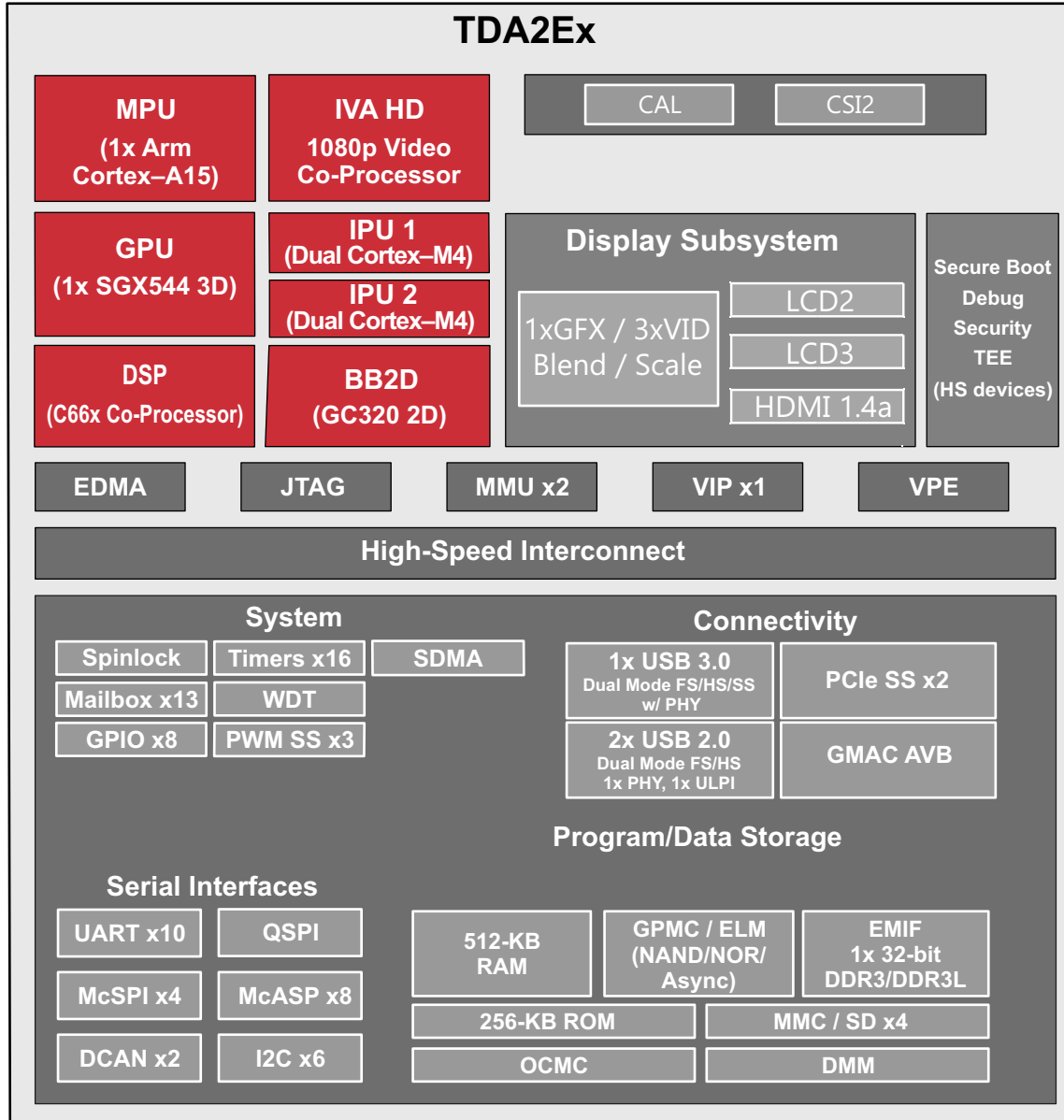

intro-001

Figure 6-1. TDA2Ex Block Diagram

### 6.3 MPU

The Cortex®-A15 microprocessor unit (MPU) subsystem serves the applications processing role by running the high-level operating system (HLOS) and application code.

The MPU subsystem incorporates one Cortex-A15 MPU core (MPU\_C0), individual level 1 (L1) caches, level 2 (L2) cache (MPU\_L2CACHE) shared between them, and various other shared peripherals. To aid software development, the processor core can be kept cache-coherent with the L2 cache.

The MPU subsystem provides a high-performance computing platform with high peak-computing performance and low memory latency.

The Arm subsystem supports the following key features:

- Arm® Cortex-A15 MP Core (MPU\_CLUSTER)
  - One Cortex-A15 MPU core (revision r2p2) which has the following features:
    - Superscalar, dynamic multi-issue technology
      - Out-of-order (OoO) instruction dispatch and completion
      - Dynamic branch prediction with branch target buffer (BTB), global history buffer (GHB), and 48-entry return stack
      - Continuous fetch and decoding of three instructions per clock cycle
      - Dispatch of up to four instructions and completion of eight instructions per clock cycle
      - Provides optimal performance from binaries compiled for previous Arm processors
      - Five execution units handle simple instructions, branch instructions, Neon and floating point instructions, multiply instructions, and load and store instructions.
      - Simple instructions take two cycles from dispatch, while complex instructions take up to 11 cycles.
      - Can issue two simple instructions in a cycle
      - Can issue a load and a store instruction in the same cycle
    - Integrated Neon processing engine to include the Arm Neon Advanced SIMD (single instruction, multiple data) support for accelerated media and signal processing computation
    - Includes VFPv4-compatible hardware to support single- and double-precision add, subtract, divide, multiply and accumulate, and square root operations
    - Extensive support to accelerate virtualization using a hypervisor
    - 32-KiB L1 instruction (L1I) and 32-KiB L1 data (L1D) cache:
      - 64-byte line size
      - 2-way set associative
    - Memory management unit (MMU):
      - Two-level translation lookaside buffer (TLB) organization
        - First level is an 32-entry, fully associative micro-TLB implemented for each of instruction fetch, load, and store.
        - Second level is a unified, 4-way associative, 512-entry main TLB
      - Supports hardware TLB table-walk for backward-compatible and new 64-bit entry page table formats
      - New page table format can produce 40-bit physical addresses
      - Two-stage translation where first stage is HLOS-controlled and the second level may be controlled by a hypervisor. Second stage always uses the new page table format
  - Integrated L2 cache (MPU\_L2CACHE) and snoop control unit (SCU):
    - 1-MiB of unified (instructions and data) cache organized as 16 ways of 1024 sets of 64-byte lines
    - Redundant L1 data (cache) tags to perform snoop filtering (L1 instruction cache tags are not duplicated)
    - Operates at Cortex-A15 MPU core clock rate
    - Integrated L2 cache controller (MPU\_L2CACHE\_CTRL):
      - Sixteen 64-byte line buffers that handle evictions, line fills and snoop transfers
      - One 128-bit AMBA4 Coherent Bus (AXI4-ACE) port
      - Auto-prefetch buffer for up to 16 streams and detecting forward and backward strides
  - Generalized interrupt controller (GIC, also referred to as MPU\_INTIC): An interrupt controller supplied by Arm. The single GIC in the MPU\_CLUSTER routes interrupts to the MPU core. The GIC supports:
    - Number of shared peripheral interrupts (SPI): 160
    - Number of software generated interrupts (SGI): 16
    - Number of CPU interfaces: 1

- Virtual CPU interface for virtualization support. This allows the majority of guest operating system (OS) interactions with the GIC to be handled in hardware, but with physical interrupts still requiring hypervisor intervention to assign them to the appropriate virtual machine.
- Integrated timer counter and one timer block
- Arm CoreSight debug and trace modules. For more information, see chapter *On-Chip Debug Support* of the Device TRM..
- MPU\_AXI2OCP bridge (local interconnect):
  - Connected to Memory Adapter (MPU\_MA), which routes the non-EMIF address space transactions to MPU\_AXI2OCP
  - Single request multiple data (SRMD) protocol on L3\_MAIN port
  - Multiple targets:
    - 64-bit port to the L3\_MAIN interconnect. Interface frequency is 1/4 or 1/8 of core frequency
    - MPU\_ROM
    - Internal MPU subsystem peripheral targets, including Memory Adapter LISA Section Manager (MA\_LSM), wake-up generator (MPU\_WUGEN), watchdog timer (MPU\_WD\_TIMER), and local PRCM module (MPU\_PRCM) configuration
    - Internal AXI target, CoreSight System Trace Module (CS\_STM)
- Memory adapter (MPU\_MA): Helps decrease the latency of accesses between the MPU\_L2CACHE and the external memory interface (EMIF1) by providing a direct path between the MPU subsystem and EMIF1:
  - Connected to 128-bit AMBA4 interface of MPU\_CLUSTER
  - Direct 128-bit interface to EMIF1
  - Interface speed between MPU\_CLUSTER and MPU\_MA is at half-speed of the MPU core frequency
  - Quarter-speed interface to EMIF
  - Uses firewall logic to check access rights of incoming addresses
- Local PRCM (MPU\_PRCM):
  - Handles MPU\_C0 power domain
  - Supports SR3-APG (SmartReflex3 Automatic Power Gating) power management technology inside the MPU\_CLUSTER
  - MPU subsystem has five power domains
- Wake-up generator (MPU\_WUGEN)
  - Responsible for waking up the MPU core
- Standby controller: Handles the power transitions inside the MPU subsystem
- Realtime (master) counter (COUNTER\_REALTIME): Produces the count used by the private timer peripheral in the MPU\_CLUSTER
- Watchdog timer (MPU\_WD\_TIMER): Used to generate a chip-level watchdog reset request to global PRCM
- On-chip boot ROM (MPU\_ROM): The MPU\_ROM size is 48-KiB, and the address range is from 0x4003 8000 to 0x4004 3FFF. For more information about booting from this memory, see chapter *Initialization* of the Device TRM..

- Interfaces:
  - 128-bit interface to EMIF1
  - 64-bit master port to the L3\_MAIN interconnect
  - 32-bit slave port from the L4\_CFG\_EMU interconnect (debug subsystem) for configuration of the MPU subsystem debug modules
  - 32-bit slave port from the L4\_CFG interconnect for memory adapter firewall (MPU\_MA\_NTTP\_FW) configuration
  - 32-bit ATB output for transmitting debug and trace data
  - 160 peripheral interrupt inputs

For more information, see section *Arm Cortex-A15 Subsystem* in chapter *Processors and Accelerators* of the device TRM.

## 6.4 DSP Subsystem

The device includes a single instance (DSP1) of a digital signal processor (DSP) subsystem, based on the TI's standard TMS320C66x DSP CorePac core.

The TMS320C66x DSP core enhances the TMS320C674x™ core, which merges the C674x™ floating point and the C64x+™ fixed-point instruction set architectures. The C66x DSP is object-code compatible with the C64x+/C674x DSPs.

For more information on the TMS320C66x core CPU, see the *TMS320C66x DSP CPU and Instruction Set Reference Guide*, ([SPRUGH7](#)).

The DSP subsystem integrated in the device includes the following components:

- A TMS320C66x CorePac DSP core that encompasses:
  - L1 program-dedicated (L1P) cacheable memory
  - L1 data-dedicated (L1D) cacheable memory
  - L2 (program and data) cacheable memory
  - Extended Memory Controller (XMC)
  - External Memory Controller (EMC)
  - DSP CorePac located interrupt controller (INTC)
  - DSP CorePac located power-down controller (PDC)
- Dedicated enhanced data memory access engine - EDMA, to transfer data from/to memories and peripherals external to the DSP subsystem and to local DSP memory (most commonly L2 SRAM). The external DMA requests are passed through DSP system level (SYS) wakeup logic, and collected from the DSP1 dedicated outputs of the device DMA Events Crossbar for the subsystem.
- A level 2 (L2) interconnect network (DSP NoC) to allow connectivity between different modules of the subsystem or the remainder of the device via the device L3\_MAIN interconnect.
- Two memory management units (on EDMA L2 interconnect and DSP MDMA paths) for accessing the device L3\_MAIN interconnect address space
- Dedicated system control logic (DSP\_SYSTEM) responsible for power management, clock generation, and connection to the device power, reset, and clock management (PRCM) module

The TMS320C66x Instruction Set Architecture (ISA) is the latest for the C6000 family. As with its predecessors (C64x, C64x+ and C674x), the C66x is an advanced VLIW architecture with 8 functional units (two multiplier units and six arithmetic logic units) that operate in parallel. The C66x CPU has a total of 64 general-purpose 32-bit registers.

Some features of the DSP C6000 family devices are:

- Advanced VLIW CPU with eight functional units (two multipliers and six ALUs) which:
  - Executes up to eight instructions per cycle for up to ten times the performance of typical DSPs
  - Allows designers to develop highly effective RISC-like code for fast development time



- Instruction packing
  - Gives code size equivalence for eight instructions executed serially or in parallel
  - Reduces code size, program fetches, and power consumption
- Conditional execution of most instructions
  - Reduces costly branching
  - Increases parallelism for higher sustained performance
- Efficient code execution on independent functional units
  - Industry's most efficient C compiler on DSP benchmark suite
  - Industry's first assembly optimizer for fast development and improved parallelization
- 8-/16-/32-bit/64-bit data support, providing efficient memory support for a variety of applications
- 40-bit arithmetic options which add extra precision for vocoders and other computationally intensive applications
- Saturation and normalization to provide support for key arithmetic operations
- Field manipulation and instruction extract, set, clear, and bit counting support common operation found in control and data manipulation applications.

The C66x CPU has the following additional features:

- Each multiplier can perform two 16 × 16-bit or four 8 × 8 bit multiplies every clock cycle.
- Quad 8-bit and dual 16-bit instruction set extensions with data flow support
- Support for non-aligned 32-bit (word) and 64-bit (double word) memory accesses
- Special communication-specific instructions have been added to address common operations in error-correcting codes.
- Bit count and rotate hardware extends support for bit-level algorithms.
- Compact instructions: Common instructions (AND, ADD, LD, MPY) have 16-bit versions to reduce code size.
- Protected mode operation: A two-level system of privileged program execution to support higher-capability operating systems and system features such as memory protection.
- Exceptions support for error detection and program redirection to provide robust code execution
- Hardware support for modulo loop operation to reduce code size and allow interrupts during fully-pipelined code
- Each multiplier can perform 32 × 32 bit multiplies
- Additional instructions to support complex multiplies allowing up to eight 16-bit multiply/add/subtracts per clock cycle

The TMS320C66x has the following key improvements to the ISA:

- 4x Multiply Accumulate improvement for both fixed and floating point
- Improvement of the floating point arithmetic
- Enhancement of the vector processing capability for fixed and floating point
- Addition of domain-specific instructions for complex arithmetic and matrix operations

**On the C66x ISA, the vector processing capability is improved by extending the width of the SIMD instructions.** The C674x DSP supports 2-way SIMD operations for 16-bit data and 4-way SIMD operations for 8-bit data. C66x enhances this capabilities with the addition of SIMD instructions for 32-bit data allowing operation on 128-bit vectors. For example the QMPY32 instruction is able to perform the element to element multiplication between two vectors of four 32-bit data each.

C66x ISA includes a set of specific instructions to handle complex arithmetic and matrix operations.

- **TMS320C66x DSP CorePac memory components:**
  - A 32-KiB L1 program memory (L1P) configurable as cache and/or SRAM:
    - When configured as a cache, the L1P is a 1-way set-associative cache with a 32-byte cache line
    - The DSP CorePac L1P memory controller provides bandwidth management, memory protection, and power-down functions
    - The L1P is capable of cache block and global coherence operations
    - The L1P controller has an Error Detection (ED) mechanism, including necessary SRAM
    - The L1P memory can be fully configured as a cache or SRAM
    - Page size for L1P memory is 2KB
  - A 32-KiB L1 data memory (L1D) configurable as cache and / or SRAM:
    - When configured as a cache, the L1D is a 2-way set-associative cache with a 64-byte cache line
    - The DSP CorePac L1D memory controller provides bandwidth management, memory protection, and power-down functions
    - The L1D memory can be fully configured as a cache or SRAM
    - No support for error correction or detection
    - Page size for L1D memory is 2KB
  - A 288-KiB (program and data) L2 memory, only part of which is cacheable:
    - When configured as a cache, the L2 memory is a 4-way set associative cache with a 128-byte cache line
    - Only 256 KiB of L2 memory can be configured as cache or SRAM
    - 32 KiB of the L2 memory is always mapped as SRAM
    - The L2 memory controller has an Error Correction Code (ECC) and ED mechanism, including necessary SRAM
    - The L2 memory controller supports hardware prefetching and also provides bandwidth management, memory protection, and power-down functions.
    - Page size for L2 memory is 16KB
- The **External Memory Controller (EMC)** is a bridge from the C66x CorePac to the rest of the DSP subsystem and device. It has :
  - a 32-bit configuration port (CFG) providing access to local subsystem resources (like DSP\_EDMA, DSP\_SYSTEM, and so forth) or to L3\_MAIN resources accessible via the CFG address range.
  - a 128-bit slave-DMA port (SDMA) which provides accesses of system masters outside the DSP subsystem to resources inside the DSP subsystem or C66x DSP CorePac memories, i.e. when the DSP subsystem is the slave in a transaction.
- The **Extended Memory Controller (XMC)** processes requests from the L2 Cache Controller (which are a result of CPU instruction fetches, load/store commands, cache operations) to device resources via the C66x DSP CorePac 128-bit master DMA (MDMA) port:
  - Memory protection for addresses outside C66x DSP CorePac generated over device L3\_MAIN on the MDMA port
  - Prefetch, multi-in-flight requests
- A DSP local **Interrupt Controller (INTC)** in the DSP C66x CorePac, interfaces the system events to the DSP C66x core CPU interrupt and exceptions inputs. The DSP subsystem C66x CorePac interrupt controller supports up to 128 system events of which 64 interrupts are external to DSP subsystem, collected from the DSP1 dedicated outputs of the device Interrupt Crossbar.

- **Local Enhanced Direct Memory Access (EDMA) controller features:**
  - Channel controller (CC) : 64-channel, 128 PaRAM, 2 Queues
  - 2 x Third-party Transfer Controllers (TPTC0 and TPTC1):
    - Each TC has a 128-bit read port and a 128-bit write port
    - 2KiB FIFOs on each TPTC
  - 1-dimensional/2-dimensional (1D/2D) addressing
  - Chaining capability
- **DSP subsystem integrated MMUs:**
  - Two MMUs are integrated:
    - The MMU0 is located between DSP MDMA master port and the device L3\_MAIN interconnect and can be optionally bypassed
    - The MMU1 is located between the EDMA master port and the device L3\_MAIN interconnect
- A DSP local **Power-Down Controller (PDC)** is responsible to power-down various parts of the DSP C66x CorePac, or the entire DSP C66x CorePac.
- The DSP subsystem **System Control logic** provides:
  - Slave idle and master standby protocols with device PRCM for powerdown
  - OCP Disconnect handshake for init and target busses
  - Asynchronous reset
  - Power-down modes:
    - "Clockstop" mode featuring wake-up on interrupt event. The DMA event wake-up is managed in software.
- The device DSP subsystem is supplied by a PRCM DPLL, but DSP1 **has integrated its own PLL module** outside the C66x CorePac for clock gating and division.
- **The device DSP subsystem has following port instances** to connect to remaining part of the device. See also :
  - A 128-bit initiator (DSP MDMA master) port for MDMA/Cache requests
  - A 128-bit initiator (DSP EDMA master) port for EDMA requests
  - A 32-bit initiator (DSP CFG master) port for configuration requests
  - A 128-bit target (DSP slave) port for requests to DSP memories and various peripherals
- **C66x DSP subsystem (DSPSS) safety aspects:**
  - Above mentioned memory ECC/ED mechanisms
  - MMUs enable mapping of only the necessary application space to the processor
  - Memory Protection Units internal to the DSPSS (in L1P, L1D and L2 memory controllers) and external to DSPSS (firewalls) to help define legal accesses and raise exceptions on illegal accesses
  - Exceptions: Memory errors, various DSP errors, MMU errors and some system errors are detected and cause exceptions. The exceptions could be handled by the DSP or by a designated safety processor at the chip level. Note that it may not be possible for the safety processor to completely handle some exceptions

#### Unsupported features on the C66x DSP core for the device are:

- The Extended Memory Controller MPAX (memory protection and address extension) 36-bit addressing is NOT supported

#### Known DSP subsystem powermode restrictions for the device are:

- "Full logic / RAM retention" mode featuring wake-up on both interrupt or DMA event (logic in "always on" domain). Only OFF mode is supported by DSP subsystem, **requiring full boot.**

For more information about:

- C66x debug/trace support, see chapter *On-Chip Debug* of the device TRM.

## 6.5 IVA

The IVA supports resolutions up to 1080 p/i with full performance of 60 fps (or 120 fields), achievable for encode or decode only (not for simultaneous encode and decode).

The IVA subsystem is composed of:

- A primary sequencer, including its memories and an imaging controller: ICONT1
- A video direct memory access (VDMA) processor, which can be used as a secondary sequencer: ICONT2
- A VDMA engine: DMA\_IVA
- An entropy codec: ECD3
- A motion compensation engine: MC3
- A transform and quantization calculation engine: CALC3
- A loop filter acceleration engine: ILF3
- A motion estimation acceleration engine: IME3
- An intraprediction estimation engine: IPE3
- Shared level 2 (L2) interface and memory
- Local interconnect (L4\_IVA)
- A message interface for communication between SYNCBOXes
- Mailbox
- A debug module for trace event and software instrumentation: SMSET

---

### NOTE

The IVA allows execution of compliant codecs through the software development kit (SDK). Refer to the SDK documentation for details.

---

For more information, see chapter *IVA Subsystem* of the device TRM.

## 6.6 IPU

The device instantiates two dual Cortex®-M4 image processor unit (IPU) subsystems:

- IPU1 subsystem is available for general purpose usage
- IPU2 subsystem is dedicated to IVA support and is not available for other processing

---

### NOTE

The two IPU subsystems are identical from functional point of view. Thus, a unified name **IPUx** shall be used throughout the chapter for simplification.

---

Each IPU subsystem contains two Arm® Cortex-M4 processors (IPUx\_C0 and IPUx\_C1) that share a common level 1 (L1) cache (called unicache [IPUx\_UNICACHE]). The two Cortex-M4 cores are completely homogeneous to one another. Any task possible using one Cortex-M4 core is also possible using the other Cortex-M4 core. It is software responsibility to distribute the various tasks between each Cortex-M4 core for optimal performance.

The integrated interrupt handling of the IPUx subsystem allows it to function as an efficient control unit.

Each IPU subsystem integrates the following:

- Two Arm Cortex-M4 microprocessors (IPUx\_C0 and IPUx\_C1):
  - Armv7-M and Thumb<sup>®</sup>-2 instruction set architecture (ISA)
  - Armv6 SIMD and digital signal processor (DSP) extensions
  - Single-cycle MAC
  - Integrated nested vector interrupt controller (NVIC) (also called IPUx\_Cx\_INTC, where x = 0, 1)
  - Integrated bus matrix
  - Registers:
    - Thirteen general-purpose 32-bit registers
    - Link register (LR)
    - Program counter (PC)
    - Program status register, xPSR
    - Two banked SP registers
  - Integrated power management
  - Extensive debug capabilities
- Unicache interface:
  - Instruction and data interface
  - Supports paralleled accesses
- Level 2 (L2) master interface (MIF) splitter for access to memory or configuration port
- Configuration port: Used for unicache maintenance and unicache memory management unit (IPUx\_UNICACHE\_MMU) configuration
- Unicache:
  - 32 KiB divided into 16 banks
  - 4-way
  - Cache configuration lock/freeze/preload
  - Internal MMU:
    - 16-entry region-based address translation
    - Read/write control and access type control
    - Execute Never (XN) MMU protection policy
    - Little-endian format
- Subsystem counter timer module (IPUx\_UNICACHE\_SCTM, or just SCTM)
- On-chip ROM (IPUx\_ROM) and banked RAM (IPUx\_RAM) memory
- Emulation/debug: Emulation feature embedded in Cortex-M4
- L2 MMU (IPUx\_MMU): 32 entries with table walking logic
- Wake-up generator (IPUx\_WUGEN): Generates wake-up request from external interrupts
- Power management:
  - Local power-management control: Configurable through the IPUx\_WUGEN registers.
  - Three sleep modes supported, controlled by the local power-management module.
  - IPUx is clock-gated in all sleep modes.
  - IPUx\_Cx\_INTC interrupt interface stays awake.

For more information, see chapter *Dual Cortex-M4 IPU Subsystem* of the device TRM.

## 6.7 GPU

The 3D graphics processing unit (GPU) accelerates 2-dimensional (2D) and 3-dimensional (3D) graphics and compute applications. It is based on the POWERVR SGX544-MP subsystem from Imagination Technologies.

SGX is a new generation of programmable POWERVR graphics and video processing subsystems. The POWERVR SGX is a scalable architecture which efficiently processes a number of differing multimedia data types concurrently:

- Pixel Data
- Vertex Data
- General Purpose Processing
- API support for industry standards:
  - OpenCL™-EP 1.1
  - Direct3D® Feature Level 9.3
- Single-core GPU architecture:
  - 1 × SGX544 core
  - System level cache of 64 KiB
- Tile-based deferred rendering architecture:
  - Reduces external bandwidth to SDRAM
- Universal Scalable Shader Engine (USSE™):
  - Multithreaded engine incorporating vertex and pixel shader functionality
  - Automatic load balancing of vertex and pixel processing tasks
- Present and texture load accelerator (PTLA):
  - Enables to move, rotate, twiddle, and scale texture surfaces
  - Supports RGB, ARGB, YUV4:2:2, and YUV4:2:0 surface formats
  - Supports bilinear upscale
  - Supports source color key
- Fully virtualized memory addressing for operating system (OS) in a unified memory architecture:
  - Memory management unit (MMU)
  - Up to 4-GiB virtual address space

The 3D-GPU subsystem generates a single (aggregate) interrupt connected to the device Interrupt Crossbar. This allows for this interrupt to be programmatically mapped to multiple device host interrupt controllers.

- Texture support:
  - Cube map
  - Projected textures
  - Non-square textures
- Texture formats:
  - RGBA 8888, 565, 1555, and 1565
  - Monochromatic 8, 16, 16f, 32f, and 32int
  - Dual channel, 8:8, 16:16, and 16f:16f
  - Compressed textures:
    - PVRTC-i 2 bpp
    - PVRTC-i 4 bpp
    - PVRTC-ii 2 bpp
    - PVRTC-ii 4 bpp
    - ETC1
    - DXT 1-5 and BC 4-5
  - Programmable support for YUV formats:
    - Programmable matrix in hardware, coefficients on 12 bits
    - YUV4:2:2, YUV4:2:0, two planes (NV12 or NV21); YUV4:2:0, three planes

- Resolution support:
  - Frame buffer maximum = 4096 × 4096
  - Texture maximum size = 4096 × 4096
- Texture filtering:
  - Bilinear, trilinear
  - Independent minimum and mag control
- Anti-aliasing:
  - 4x multisampling
  - Programmable sample positions

For more information, see chapter *3D Graphics Accelerator* of the device TRM.

## 6.8 BB2D

The 2D graphics accelerator subsystem accelerates 2D graphics applications. The 2D graphics accelerator subsystem is based on the GC320 2D GPU core from Vivante Corporation. The hardware acceleration is brought to numerous 2D applications, including on-screen display and touch screen user interfaces, graphical user interfaces (GUIs) and menu displays, flash animation, and gaming.

- API support:
  - OpenWF™, DirectFB
  - GDI/DirectDraw™
  - Flash
- **BB2D architecture:**
  - BitBlit and StretchBlit
  - DirectFB hardware acceleration
  - ROP2, ROP3, ROP4 full alpha blending and transparency
  - Clipping rectangle support
  - Alpha blending includes Java® 2 Porter-Duff compositing rules
  - 90-, 180-, 270-degree rotation on every primitive
  - YUV-to-RGB color space conversion
  - Programmable display format conversion with 14 source and 7 destination formats
  - High-quality 9-tap, 32-phase filter for image and video scaling at 1080p
  - Monochrome expansion for text rendering
  - 32 K × 32 K coordinate system
- **Hardware acceleration for DirectFB:**
  - High-speed video scaler
  - ROP2/3/4
  - Rectangle filling and drawing
  - Line drawing
  - Simple blitting
  - Stretch blitting
  - Blending with alpha channel (per-pixel alpha)
  - Blending with alpha factor (alpha modulation)
  - Nine source and destination blending functions
  - Porter-Duff rules support
  - Premultiplied alpha support
  - Colorized blitting (color modulation)
  - Source color keying
  - Destination color keying

The device BB2D generates a single (aggregate) interrupt request connected to the device Interrupt Crossbar. This allows for this interrupt to be programmatically mapped to multiple device host interrupt controllers.

For more information, see chapter *2D Graphics Accelerator* of the device TRM.



## 6.9 Memory Subsystem

### 6.9.1 EMIF

The EMIF module provides connectivity between DDR memory types and manages data bus read/write accesses between external memory and device subsystems which have master access to the L3\_MAIN interconnect and DMA capability.

The EMIF module has the following capabilities:

- Supports JEDEC standard-compliant DDR3/DDR3L-SDRAM memory types
- 2-GiB SDRAM address range over one chip-select. This range is configurable through the dynamic memory manager (DMM) module
- Supports SDRAM devices with one, two, four or eight internal banks
- Supports SDRAM devices with single or dual die packages
- Data bus widths:
  - 128-bit L3\_MAIN (system) interconnect data bus width
  - 128-bit port for direct connection with MPU subsystem
  - 32-bit SDRAM data bus width
  - 16-bit SDRAM data bus width used in narrow mode
- Supported CAS latencies:
  - DDR3: 5, 6, 7, 8, 9, 10 and 11
- Supports 256-, 512-, 1024-, and 2048-word page sizes
- Supported burst length: 8
- Supports sequential burst type
- SDRAM auto initialization from reset or configuration change
- Supports self refresh and power-down modes for low power
- Partial array self-refresh mode for low power.
- Output impedance (ZQ) calibration for DDR3
- Supports on-die termination (ODT) DDR3
- Supports prioritized refresh
- Programmable SDRAM refresh rate and backlog counter
- Programmable SDRAM timing parameters
- Write and read leveling/calibration and data eye training for DDR3.

The EMIF module does not support:

- Burst chop for DDR3
- Interleave burst type
- Auto precharge because of better Bank Interleaving performance
- DLL disabling from EMIF side
- SDRAM devices with more than one die, or topologies which require more than one chip select on a single EMIF channel

For more information, see section *DDR External Memory Interface (EMIF)* in chapter *Memory Subsystem* of the device TRM.

### 6.9.2 GPMC

The General Purpose Memory Controller (GPMC) is an external memory controller of the device. Its data access engine provides a flexible programming model for communication with all standard memories.

The GPMC supports the following various access types:

- Asynchronous read/write access

- Asynchronous read page access (4, 8, and 16 Word16)
- Synchronous read/write access
- Synchronous read/write burst access without wrap capability (4, 8 and 16 Word16)
- Synchronous read/write burst access with wrap capability (4, 8 and 16 Word16)
- Address-data-multiplexed (AD) access
- Address-address-data (AAD) multiplexed access
- Little- and big-endian access

The GPMC can communicate with a wide range of external devices:

- External asynchronous or synchronous 8-bit wide memory or device (non burst device)
- External asynchronous or synchronous 16-bit wide memory or device
- External 16-bit non-multiplexed NOR flash device
- External 16-bit address and data multiplexed NOR Flash device
- External 8-bit and 16-bit NAND flash device
- External 16-bit pseudo-SRAM (pSRAM) device

The main features of the GPMC are:

- 8- or 16-bit-wide data path to external memory device
- Supports up to eight CS regions of programmable size and programmable base addresses in a total address space of 1 GiB
- Supports transactions controlled by a firewall
- On-the-fly error code detection using the Bose-Chaudhuri-Hocquenghem (BCH) ( $t = 4, 8, \text{ or } 16$ ) or Hamming code to improve the reliability of NAND with a minimum effect on software (NAND flash with 512-byte page size or greater)
- Fully pipelined operation for optimal memory bandwidth use
- The clock to the external memory is provided from GPMC functional clock divided by 1, 2, 3, or 4
- Supports programmable autoclock gating when no access is detected
- Independent and programmable control signal timing parameters for setup and hold time on a per-chip basis. Parameters are set according to the memory device timing parameters, with a timing granularity of one GPMC functional clock cycle.
- Flexible internal access time control (WAIT state) and flexible handshake mode using external WAIT pin monitoring
- Support bus keeping
- Support bus turnaround
- Prefetch and write posting engine associated with to achieve full performance from the NAND device with minimum effect on NOR/SRAM concurrent access

For more information, see section *General-Purpose Memory Controller (GPMC)* in chapter *Memory Subsystem* of the device TRM.

### 6.9.3 ELM

In the case of NAND modules with no internal correction capability, sometimes referred to as bare NAND, the correction process can be delegated to the error location module (ELM) used in conjunction with the GPMC.

The ELM supports the following features:

- 4, 8, and 16 bits per 512-byte block error location based on BCH algorithm
- Eight simultaneous processing contexts
- Page-based and continuous modes

- Interrupt generation when error location process completes:
  - When the full page has been processed in page mode
  - For each syndrome polynomial (checksum-like information) in continuous mode

For more information, see section *Error Location Module (ELM)* in chapter *Memory Subsystem* of the device TRM.

#### 6.9.4 OCMC

There is one on-chip memory controller (OCMC) in the device.

The OCM Controller supports the following features:

- L3\_MAIN data interface:
  - Used for maximum throughput performance
  - 128-bit data bus width
  - Burst supported
- L4 interface (OCMC\_RAM only):
  - Used for access to configuration registers
  - 32-bit data bus width
  - Only single accesses supported
  - The L4 associated OCMC clock is two times lower than the L3 associated OCMC clock
- Error correction and detection:
  - Single error correction and dual error detection
  - 9-bit Hamming error correction code (ECC) calculated on 128-bit data word which is concatenated with memory address bits
  - Hamming distance of 4
  - Enable/Disable mode control through a dedicated register
  - Single bit error correction on a read transaction
  - Exclusion of repeated addresses from correctable error address trace history
  - ECC valid for all write transactions to an enabled region
  - Sub-128-bit writes supported via read modify write
- ECC Error Status Reporting:
  - Trace history buffer (FIFO) with depth of 4 for corrected error address
  - Trace history buffer with depth of 4 for non correctable error address and also including double error detection
  - Interrupt generation for correctable and uncorrectable detected errors
- ECC Diagnostics Configuration:
  - Counters for single error correction (SEC), double error detection (DED) and address error events (AEE)
  - Programmable threshold registers for exceptions associated with SEC, DED and AEE counters
  - Register control for enabling and disabling of diagnostics
  - Configuration registers and ECC status accessible through L4 interconnect
- Circular buffer for sliced based VIP frame transfers:
  - Up to 12 programmable circular buffers mapped with unique virtual frame addresses
  - On the fly (with no additional latency) address translation from virtual to OCMC circular buffer memory space
  - Virtual frame size up to 8 MiB and circular buffer size up to 1 MiB
  - Error handling and reporting of illegal CBUF addressing
  - Underflow and Overflow status reporting and error handling
  - Last access read/write address history

- Two Interrupt outputs configured independently to service either ECC or CBUF interrupt events

The OCM controller does not have a memory protection logic and does not support endianness conversion.

For more information, see section *On-Chip Memory (OCM)* in chapter *Memory Subsystem* of the device TRM.

## 6.10 Interprocessor Communication

### 6.10.1 MailBox

Communication between the on-chip processors of the device uses a queued mailbox-interrupt mechanism.

The queued mailbox-interrupt mechanism allows the software to establish a communication channel between two processors through a set of registers and associated interrupt signals by sending and receiving messages (mailboxes).

The device implements the following mailbox types:

- System mailbox:
  - Number of instances: 13
  - Used for communication between: MPU, DSP1, IPU1, and IPU2 subsystems
  - Reference name: MAILBOX(1..13)
- IVA mailbox:
  - Number of instances: 1
  - Used for communication between: IVA local user (ICONT1, or ICONT2) and three external users (selected among MPU, DSP1, IPU1, and IPU2 subsystems)
  - Reference name: IVA\_MBOX

Each mailbox module supports the following features:

- Parameters configurable at design time
  - Number of users
  - Number of mailbox message queues
  - Number of messages (FIFO depth) for each message queue
- 32-bit message width
- Message reception and queue-not-full notification using interrupts
- Support of 16-/32-bit addressing scheme
- Power management support

For more information, see chapter *MailBox* of the device TRM.

### 6.10.2 Spinlock

The Spinlock module provides hardware assistance for synchronizing the processes running on multiple processors in the device:

- Cortex®-A15 microprocessor unit (MPU) subsystem
- Digital signal processor (DSP) subsystem – DSP1
- Dual Cortex-M4 image processing unit (IPU) subsystems – IPU1 and IPU2

The Spinlock module implements 256 spinlocks (or hardware semaphores), which provide an efficient way to perform a lock operation of a device resource using a single read-access, avoiding the need of a readmodify- write bus transfer that the programmable cores are not capable of.

For more information, see chapter *Spinlock Module* of the device TRM.

## 6.11 Interrupt Controller

The device has a large number of interrupts to service the needs of its many peripherals and subsystems. The MPU, DSP, and IPU (x2) subsystems are capable of servicing these interrupts via their integrated interrupt controllers. In addition, each processor's interrupt controller is preceded by an Interrupt Controller Crossbar (IRQ\_CROSSBAR) that provides flexibility in mapping the device interrupts to processor interrupt inputs. For more information about IRQ crossbar, see chapter *Control Module* of the Device TRM.

### **Cortex®-A15 MPU Subsystem Interrupt Controller (MPU\_INTC)**

The MPU\_INTC module (also called Generalized Interrupt Controller [GIC]) is a single functional unit that is integrated in the Arm Cortex-A15 multiprocessor core (MPCore) alongside Cortex-A15 processor. It provides:

- 160 hardware interrupt inputs
- Generation of interrupts by software
- Prioritization of interrupts
- Masking of any interrupts
- Distribution of the interrupts to the target Cortex-A15 processor(s)
- Tracking the status of interrupts

The Cortex-A15 processor supports three main groups of interrupt sources, with each interrupt source having a unique ID:

- *Software Generated Interrupts (SGIs)*: SGIs are generated by writing to the Cortex-A15 Software Generated Interrupt Register (GICD\_SGIR). A maximum of 16 SGIs (ID0–ID15) can be generated for the CPU interface. An SGI has edge-triggered properties. The software triggering of the interrupt is equivalent to the edge transition of the interrupt signal on a peripheral input.
- *Private Peripheral Interrupts (PPIs)*: A PPI is an interrupt generated by a peripheral that is specific to the processor. Although interrupts ID16–ID31 are dedicated to PPIs in general, only seven PPIs are actually used for the CPU interface (ID25–ID31). Interrupts ID16–ID24 are reserved (not used).
- *Shared Peripheral Interrupts (SPIs)*: SPIs are triggered by events generated on associated interrupt input lines. In this device, the GIC is configured to support 160 SPIs corresponding to its external IRQS[159:0] signals.

For detailed information about this module and description of SGIs and PPIs, see the *Arm Cortex-A15 MPCore Technical Reference Manual* (available at [infocenter.arm.com/help/index.jsp](http://infocenter.arm.com/help/index.jsp)).

### **C66x DSP Subsystem Interrupt Controller (DSP1\_INTC)**

The DSP1 subsystem integrates an interrupt controller - DSP1\_INTC, which interfaces the system events to the C66x core interrupt and exceptions inputs. It combines up to 128 interrupts into 12 prioritized interrupts presented to the C66x CPU.

For detailed information about this module, see chapter *DSP Subsystem* of the Device TRM.

### **Dual Cortex-M4 IPU Subsystem Interrupt Controller (IPUx\_Cx\_INTC, where x = 1, 2)**

There are two Image Processing Unit (IPU) subsystems in the device - IPU1, and IPU2. Each IPU subsystem integrates two Arm Cortex-M4 cores.

A Nested Vectored Interrupt Controller (NVIC) is integrated within each Cortex-M4. The interrupt mapping is the same (per IPU) for the two cores to facilitate parallel processing. The NVIC supports:

- 64 external interrupts (in addition to 16 Cortex-M4 internal interrupts), which are dynamically prioritized with 16 levels of priority defined for each core
- Low-latency exception and interrupt handling
- Prioritization and handling of exceptions
- Control of the local power management
- Debug accesses to the processor core

For detailed information about this module, refer to *Arm Cortex-M4 Technical Reference Manual* (available at [infocenter.arm.com/help/index.jsp](http://infocenter.arm.com/help/index.jsp)).

## 6.12 EDMA

The primary purpose of the Enhanced Direct Memory Access (EDMA) controller is to service user-programmed data transfers between two memory-mapped slave endpoints on the device.

Typical usage of the EDMA controller includes:

- Servicing software-driven paging transfers (for example, data movement between external memory [such as SDRAM] and internal memory [such as DSP L2 SRAM])
- Servicing event-driven peripherals, such as a serial port
- Performing sorting or sub-frame extraction of various data structures
- Offloading data transfers from the main device CPUs, such as the C66x DSP CorePac or the Arm CorePac

The EDMA controller consists of two major principle blocks:

- EDMA Channel Controller
- EDMA Transfer Controller(s)

The EDMA Channel Controller (EDMACC) serves as the user interface for the EDMA controller. The EDMACC includes parameter RAM (PaRAM), channel control registers, and interrupt control registers. The EDMACC serves to prioritize incoming software requests or events from peripherals and submits transfer requests (TR) to the EDMA transfer controller.

The EDMA Transfer Controller (EDMATC) is responsible for data movement. The transfer request packets (TRP) submitted by the EDMACC contain the transfer context, based on which the transfer controller issues read/write commands to the source and destination addresses programmed for a given transfer.

There are two EDMA controllers present on this device:

- EDMA\_0, integrating:
  - 1 Channel Controller, referenced as: EDMACC\_0
  - 2 Transfer Controllers, referenced as: EDMACC\_0\_TC\_0 (or EDMATC\_0) and EDMACC\_0\_TC\_1 (or EDMATC\_1)
- EDMA\_1, integrating:
  - 1 Channel Controller, referenced as: EDMACC\_1
  - 2 Transfer Controllers, referenced as: EDMACC\_1\_TC\_0 (or EDMATC\_2) and EDMACC\_1\_TC\_1 (or EDMATC\_3)

The two EDMA channel controllers (EDMACC\_0 and EDMACC\_1) are functionally identical. For simplification, the unified name EDMACC shall be regularly used throughout this chapter when referring to EDMA Channel Controllers functionality and features.

The four EDMA transfer controllers (EDMACC\_0\_TC\_0, EDMACC\_0\_TC\_1, EDMACC\_1\_TC\_0 and EDMACC\_1\_TC\_1) are functionally identical. For simplification, the unified name EDMATC shall be regularly used throughout this chapter when referring to EDMA Transfer Controllers functionality and features.

Each EDMACC has the following features:

- Fully orthogonal transfer description
  - 3 transfer dimensions:
    - Array (multiple bytes)
    - Frame (multiple arrays)
    - Block (multiple frames)
  - Single event can trigger transfer of array, frame, or entire block
  - Independent indexes on source and destination

- Flexible transfer definition
  - Increment or constant addressing modes
  - Linking mechanism allows automatic PaRAM set update
  - Chaining allows multiple transfers to execute with one event
- 64 DMA channels
  - Channels triggered by either:
    - Event synchronization
    - Manual synchronization (CPU write to event set register)
    - Chain synchronization (completion of one transfer triggers another transfer)
  - Support for programmable DMA Channel to PaRAM mapping
- 8 Quick DMA (QDMA) channels
  - QDMA channels are triggered automatically upon writing to PaRAM set entry
  - Support for programmable QDMA channel to PaRAM mapping
- 512 PaRAM sets
  - Each PaRAM set can be used for a DMA channel, QDMA channel, or link set
- 2 transfer controllers/event queues
  - 16 event entries per event queue
- Interrupt generation based on:
  - Transfer completion
  - Error conditions
- Debug visibility
  - Queue water marking/threshold
  - Error and status recording to facilitate debug
- Memory protection support
  - Proxied memory protection for TR submission
  - Active memory protection for accesses to PaRAM and registers

Each EDMATC has the following features:

- Supports 2-dimensional (2D) transfers with independent indexes on source and destination (EDMACC manages the 3rd dimension)
- Up to 4 in-flight transfer requests (TR)
- Programmable priority levels
- Support for increment or constant addressing mode transfers
- Interrupt and error support
- Supports only little-endian operation in this device
- Memory mapped register (MMR) bit fields are fixed position in 32-bit MMR

For more information chapter *EDMA Controller* of the device TRM.

## 6.13 Peripherals

### 6.13.1 VIP

The VIP module provides video capture functions for the device. VIP incorporates a multi-channel raw video parser, various video processing blocks, and a flexible Video Port Direct Memory Access (VPDMA) engine to store incoming video in various formats. The device uses a single instantiation of the VIP module giving the ability of capturing up to two video streams.

A VIP module includes the following main features:

- Two independently configurable external video input capture slices (Slice 0 and Slice 1) each of which has two video input ports, Port A and Port B, where Port A can be configured as a 24/16/8-bit port, and Port B is a fixed 8-bit port.
- Each video Port A can be operated as a port with clock independent input channels (with interleaved or separated Y/C data input). Embedded sync and external sync modes are supported for all input configurations.
- Support for a single external asynchronous pixel clock, up to 165MHz per port.
- Pixel Clock Input Domain Port A supports up to one 24-bit input data bus, including BT.1120 style embedded sync for 16-bit and 24-bit data.
- Embedded Sync data interface mode supports single or multiplexed sources
- Discrete Sync data interface mode supports only single source input
- 24-bit data input plus discrete syncs can be configured to include:
  - 8-bit YUV422 (Y and U/V time interleaved)
  - 16-bit YUV422 (CbY and CrY time interleaved)
  - 24-bit YUV444
  - 16-bit RGB565
  - 24-bit RGB888
  - 12/16-bit RAW Capture
  - 24-bit RAW capture
- Discrete sync modes include:
  - VSYNC + HSYNC (FID determined by FID signal pin or HSYNC/VSYNC skew)
  - VSYNC + ACTVID + FID
  - VBLANK + ACTVID (ACTVID toggles in VBLANK) + FID
  - VBLANK + ACTVID (no ACTVID toggles in VBLANK) + FID
- Multichannel parser (embedded syncs only)
  - Embedded syncs only
  - Pixel (2x or 4x) or Line multiplexed modes supported
  - Performs demultiplexing and basic error checking
  - Supports maximum of 9 channels in Line Mux (8 normal + 1 split line)
- Ancillary data capture support
  - For 16-bit or 24-bit input, ancillary data may be extracted from any single channel
  - For 8-bit time interleaved input, ancillary data can be chosen from the Luma channel, the Chroma channel, or both channels
  - Horizontal blanking interval data capture only supported when using discrete syncs (VSYNC + HSYNC or VSYNC + HBLANK)
  - Ancillary data extraction supported on multichannel capture as well as single source streams



- Format conversion and scaling
  - Programmable color space conversion
  - YUV422 to YUV444 conversion
  - YUV444 to YUV422 conversion
  - YUV422 to YUV420 conversion
  - YUV444 Source: YUV444 to YUV444, YUV444 to RGB888, YUV444 to YUV422, YUV444 to YUV420
  - RGB888 Source: RGB888 to RGB888, RGB888 to YUV444, RGB888 to YUV422, RGB888 to YUV420
  - YUV422 Source: YUV422 to YUV422, YUV422 to YUV420, YUV422 to YUV444, YUV422 to RGB888
  - Supports RAW to RAW (no processing)
  - Scaling and format conversions do not work for multiplexed input
- Supports up to 2047 pixels wide input - when scaling is engaged
- Supports up to 3840 pixels wide input - when only chroma up/down sampling is engaged, without scaling
- Supports up to 4095 pixels wide input - without scaling and chroma up/down sampling
- The maximum supported input resolution is further limited by:
  - Pixel clock and feature-dependent constraints
  - For RGB24-bit format (RAW data), the maximum frame width is limited to 2730 pixels

For more information, see chapter *Video Input Port* of the device TRM

### 6.13.2 DSS

Display Port Interfaces (DPI) is available in DSS named DPI Video Output (VOUT).

VOUT interface consists of:

- 24-bit data bus (data[23:0])
- Horizontal synchronization signal (HSYNC)
- Vertical synchronization signal (VSYNC)
- Data enable (DE)
- Field ID (FID)
- Pixel clock (CLK)

For more information, see section *Display Subsystem (DSS)* of the device TRM.

### 6.13.3 Timers

The device includes several types of timers used by the system software, including 16 general-purpose (GP) timers, one watchdog timer, and a 32-kHz synchronized timer (COUNTER\_32K).

#### 6.13.3.1 General-Purpose Timers

The device has 16 GP timers: TIMER1 through TIMER16.

- TIMER1(1ms tick): has its event capture pin tied to 32KHz clock and can be used to gauge the system clock input and detects its frequency among 19.2, 20, or 27 MHz. It includes a specific functions to generate accurate tick interrupts to the operating system and it belongs to the PD\_WKUPAON domain
- TIMER2 and TIMER10: (1ms tick timers): they include a specific functions to generate accurate tick interrupts to the operating system, TIMER2 and TIMER10 belong to the PD\_L4PER domain
- TIMER3/4/9/11/13/14/15/16: they belongs to the PD\_L4PER domain
- TIMER12 belongs to the PD\_WKUPAON power domain
- TIMER5 trough TIMER8: belong to the PD\_IPU module

Each timer (except TIMER12) can be clocked from the system clock (19.2, 20, or 27 MHz) or the 32-kHz clock. The selection of clock source is made at the power, reset, and clock management (PRCM) module level. TIMER12 can be clocked only from the internal oscillator (on-die oscillator)

The following are the main features of the GP timer controllers:

- Level 4 (L4) slave interface support:
  - 32-bit data bus width
  - 32-/16-bit access supported
  - 8-bit access not supported
  - 10-bit address bus width
  - Burst mode not supported
  - Write nonposted transaction mode supported
- Interrupts generated on overflow, compare, and capture
- Free-running 32-bit upward counter
- Compare and capture modes
- Autoreload mode
- Start/stop mode
- Programmable divider clock source ( $2^n$ , where  $n = [0:8]$ )
- Dedicated input trigger for capture mode and dedicated output trigger/PWM signal
- Dedicated GP output signal for using the `TIMERi_GPO_CFG` signal
- On-the-fly read/write register (while counting)
- 1-ms tick with 32.768-Hz functional clock generated (only TIMER1, TIMER2, and TIMER10)

For more information, see section *Timers* of the device TRM.

### 6.13.3.2 32-kHz Synchronized Timer (COUNTER\_32K)

The 32-kHz synchronized timer (COUNTER\_32K) is a 32-bit counter clocked by the falling edge of the 32-kHz system clock.

The main features of the 32-kHz synchronized timer controller are:

- L4 slave interface (OCP) support:
  - 32-bit data bus width
  - 32-/16-bit access supported
  - 8-bit access not supported
  - 16-bit address bus width
  - Burst mode not supported
  - Write nonposted transaction mode not supported
- Only read operations are supported on the module registers; no write operation is supported (no error/no action on write).
- Free-running 32-bit upward counter
- Start and keep counting after power-on reset
- Automatic roll over to 0; highest value reached: 0xFFFF FFFF
- On-the-fly read (while counting)

For more information, see section *Timers* of the device TRM.

### 6.13.3.3 Watchdog Timer

The device includes one instance of the 32-bit watchdog timer: `WD_TIMER2`.

The watchdog timer is an upward counter capable of generating a pulse on the reset pin and an interrupt to the device system modules following an overflow condition. The WD\_TIMER2 timer serves resets to the PRCM module (its interrupt outputs are unused).

WD\_TIMER2 is located in the PD\_WKUPAON power domain, and can run when the device is in lowest power state (all power domains are off except always-on (AON) and WKUP).

The watchdog timer can be accessed, loaded, and cleared by registers through the L4\_WKUP interface. The watchdog timer has the 32-kHz clock for its timer clock input. WD\_TIMER2 directly generates a warm reset condition on overflow.

WD\_TIMER2 connects to a single target agent port on the L4\_WKUP interconnect.

The main features of the watchdog timer controllers are:

- L4 slave interface support:
  - 32-bit data bus width
  - 32-/16-bit access supported
  - 8-bit access not supported
  - 11-bit address bus width
  - Burst mode not supported
  - Write nonposted mode supported
- Free-running 32-bit upward counter
- Programmable divider clock source ( $2^n$  where  $n = [0:7]$ )
- On-the-fly read/write register (while counting)
- Subset programming model of the GP timer
- The watchdog timer is reset either on power on or after a warm reset before it starts counting.
- Reset or interrupt actions when a timer overflow condition occurs
- The watchdog timer generates a reset or an interrupt in its hardware integration.

For more information, see section *Timers* of the device TRM.

#### 6.13.4 I2C

The device contains five multimaster high-speed (HS) inter-integrated circuit (I<sup>2</sup>C) controllers (I2C<sub>i</sub> modules, where  $i = 1, 2, 3, 4, 5, 6$ ) each of which provides an interface between a local host (LH), such as a digital signal processor (DSP), and any I<sup>2</sup>C-bus-compatible device that connects through the I<sup>2</sup>C serial bus. External components attached to the I<sup>2</sup>C bus can serially transmit and receive up to 8 bits of data to and from the LH device through the 2-wire I<sup>2</sup>C interface.

Each multimaster HS I<sup>2</sup>C controller can be configured to act like a slave or master I<sup>2</sup>C-compatible device.

I<sup>2</sup>C1 and I<sup>2</sup>C2 controllers have dedicated I<sup>2</sup>C compliant open drain buffers, and support Fast mode (up to 400Kbps). I<sup>2</sup>C3, I<sup>2</sup>C4, I<sup>2</sup>C5 and I<sup>2</sup>C6 controllers are multiplexed with standard LVCMOS IO and connected to emulate open drain. I<sup>2</sup>C emulation is achieved by configuring the LVCMOS buffers to output Hi-Z instead of driving high when transmitting logic 1. These controllers support HS mode (up to 3.4Mbps).

For more information, see section *Multimaster High-Speed I2C Controller (I2C)* in chapter *Serial Communication Interfaces* of the device TRM.

#### 6.13.5 UART

The UART is a simple L4 slave peripheral that utilizes the DMA\_SYSTEM or EDMA for data transfer or IRQ polling via CPU. There are 10 UART modules in the device. Only one UART supports IrDA features. Each UART can be used for configuration and data exchange with a number of external peripheral devices or interprocessor communication between devices.

### 6.13.5.1 UART Features

The UART<sub>i</sub> (where  $i = 1$  to 10) include the following features:

- 16C750 compatibility
- 64-byte FIFO buffer for receiver and 64-byte FIFO for transmitter
- Programmable interrupt trigger levels for FIFOs
- Baud generation based on programmable divisors  $N$  (where  $N = 1 \dots 16,384$ ) operating from a fixed functional clock of 48 MHz or 192 MHz

Oversampling is programmed by software as 16 or 13. Thus, the baud rate computation is one of two options:

- Baud rate = (functional clock / 16) /  $N$
- Baud rate = (functional clock / 13) /  $N$
- This software programming mode enables higher baud rates with the same error amount without changing the clock source
- Break character detection and generation
- Configurable data format:
  - Data bit: 5, 6, 7, or 8 bits
  - Parity bit: Even, odd, none
  - Stop-bit: 1, 1.5, 2 bit(s)
- Flow control: Hardware (RTS/CTS) or software (XON/XOFF)
- The 48 MHz functional clock option allows baud rates up to 3.6Mbps
- The 192 MHz functional clock option allows baud rates up to 12Mbps
- UART1 module has extended modem control signals (DCD, RI, DTR, DSR)
- UART3 supports IrDA

### 6.13.5.2 IrDA Features

UART3 supports the following IrDA key features:

- Support of IrDA 1.4 slow infrared (SIR), medium infrared (MIR), and fast infrared (FIR) communications:
  - Frame formatting: Addition of variable beginning-of-frame (xBOF) characters and end-of-frame (EOF) characters
  - Uplink/downlink cyclic redundancy check (CRC) generation/detection
  - Asynchronous transparency (automatic insertion of break character)
  - Eight-entry status FIFO (with selectable trigger levels) to monitor frame length and frame errors
  - Framing error, CRC error, illegal symbol (FIR), and abort pattern (SIR, MIR) detection

### 6.13.5.3 CIR Features

The CIR mode uses a variable pulse-width modulation (PWM) technique (based on multiples of a programmable  $t$  period) to encompass the various formats of infrared encoding for remote-control applications. The CIR logic transmits data packets based on a user-definable frame structure and packet content.

The CIR (UART3 only) includes the following features to provide CIR support for remote-control applications:

- Transmit mode only (receive mode is not supported)
- Free data format (supports any remote-control private standards)
- Selectable bit rate
- Configurable carrier frequency
- 1/2, 5/12, 1/3, or 1/4 carrier duty cycle

For more information, see section *Universal Asynchronous Receiver/Transmitter (UART)* in chapter *Serial Communication Interfaces* of the device TRM.

### 6.13.6 **McSPI**

The McSPI is a master/slave synchronous serial bus. There are four separate McSPI modules (McSPI1, McSPI2, McSPI3, and McSPI4) in the device. All these four modules support up to four external devices (four chip selects) and are able to work as both master and slave.

The McSPI modules include the following main features:

- Serial clock with programmable frequency, polarity, and phase for each channel
- Wide selection of McSPI word lengths, ranging from 4 to 32 bits
- Up to four master channels, or single channel in slave mode
- Master multichannel mode:
  - Full duplex/half duplex
  - Transmit-only/receive-only/transmit-and-receive modes
  - Flexible input/output (I/O) port controls per channel
  - Programmable clock granularity
  - McSPI configuration per channel. This means, clock definition, polarity enabling and word width
- Single interrupt line for multiple interrupt source events
- Power management through wake-up capabilities
- Enable the addition of a programmable start-bit for McSPI transfer per channel (start-bit mode)
- Supports start-bit write command
- Supports start-bit pause and break sequence
- Programmable timing control between chip select and external clock generation
- Built-in FIFO available for a single channel

For more information, see section *Serial Peripheral Interface (McSPI)* in chapter *Serial Communication Interfaces* of the device TRM.

### 6.13.7 QSPI

The quad serial peripheral interface (QSPI™) module is a kind of SPI module that allows single, dual, or quad read access to external SPI devices. This module has a memory mapped register interface, which provides a direct interface for accessing data from external SPI devices and thus simplifying software requirements. The QSPI works as a master only.

The QSPI supports the following features:

- General SPI features:
  - Programmable clock divider
  - Six pin interface
  - Programmable length (from 1 to 128 bits) of the words transferred
  - Programmable number (from 1 to 4096) of the words transferred
  - 4 external chip-select signals
  - Support for 3-, 4-, or 6-pin SPI interface
  - Optional interrupt generation on word or frame (number of words) completion
  - Programmable delay between chip select activation and output data from 0 to 3 QSPI clock cycles
  - Programmable signal polarities
  - Programmable active clock edge
  - Software-controllable interface allowing for any type of SPI transfer
  - Control through L3\_MAIN configuration port
- Serial flash interface (SFI) features:
  - Serial flash read/write interface
  - Additional registers for defining read and write commands to the external serial flash device
  - 1 to 4 address bytes
  - Fast read support, where fast read requires dummy bytes after address bytes; 0 to 3 dummy bytes can be configured.
  - Dual read support
  - Quad read support
  - Little-endian support only
  - Linear increment addressing mode only

The QSPI supports only dual and quad reads. Dual or quad writes are not supported. In addition, there is no "pass through" mode supported where the data present on the QSPI input is sent to its output.

For more information, see section *Quad Serial Peripheral Interface (QSPI)* in chapter *Serial Communication Interfaces* of the device TRM.

### 6.13.8 McASP

The McASP functions as a general-purpose audio serial port optimized to the requirements of various audio applications. The McASP module can operate in both transmit and receive modes. The McASP is useful for time-division multiplexed (TDM) stream, Inter-IC Sound (I2S) protocols reception and transmission as well as for an intercomponent digital audio interface transmission (DIT). The McASP has the flexibility to gluelessly connect to a Sony/Philips digital interface (S/PDIF) transmit physical layer component.

Although intercomponent digital audio interface reception (DIR) mode (i.e. S/PDIF stream receiving) is not natively supported by the McASP module, a specific TDM mode implementation for the McASP receivers allows an easy connection to external DIR components (for example, S/PDIF to I2S format converters).

The device have integrated 8 McASP modules (McASP1-McASP8) with:

- McASP1 and McASP2 supporting 16 channels with independent TX/RX clock/sync domain
- McASP3 through McASP8 modules supporting 4 channels with independent TX/RX clock/sync domain

For more information, see section *Multi-channel Audio Serial Port (McASP)* in chapter *Serial Communication Interfaces* of the device TRM.

### 6.13.9 USB

SuperSpeed USB DRD Subsystem has three instances in the device providing the following functions:

- USB1: SuperSpeed (SS) USB 3.0 Dual-Role-Device (DRD) subsystem with integrated SS (USB3.0) PHY and HS/FS (USB2.0) PHY
- USB2: High-Speed (HS) USB 2.0 Dual-Role-Device (DRD) subsystem with integrated HS/FS PHY
- USB3: HS USB 2.0 Dual-Role-Device (DRD) subsystem with ULPI (SDR) interface to external HS/FS PHYs

SuperSpeed USB DRD Subsystem has the following features:

- Dual-role-device (DRD) capability:
  - Supports USB Peripheral (or Device) mode at speeds SS (5Gbps)(USB1 only), HS (480 Mbps), and FS (12 Mbps)
  - Supports USB Host mode at speeds SS (5Gbps)(USB1 only), HS (480 Mbps), FS (12 Mbps), and LS (1.5 Mbps)
  - USB static peripheral operation
  - USB static host operation
  - Flexible stream allocation
  - Stream priority
  - External Buffer Control
- Each instance contains single xHCI controller with the following features:
  - Internal DMA controller
  - Descriptor caching and data prefetching
  - Interrupt moderation and blocking
  - Power management USB3.0 states for U0, U1, U2, and U3
  - Dynamic FIFO memory allocation for all endpoints
  - Supports all modes of transfers (control, bulk, interrupt, and isochronous)
  - Supports high bandwidth ISO mode
- Connects to an external charge pump for VBUS 5 V generation
- USB-HS PHY (USB2PHY1 and USB2PHY2 for USB1 and USB2, respectively): contain the USB functions, drivers, receivers, and pads for correct D+/D– signalling
- USB3PHY. The USB3PHY is embedded in the USB1 subsystem and contains:
  - USB3RX\_PHY deserializer to receive data at SuperSpeed mode
  - USB3TX\_PHY serializer to transmit data at SuperSpeed mode
  - Power sequencer that contains a power control state machine, generating the sequences to power up/down the USB3RX\_PHY/USB3TX\_PHY
  - Dedicated DPLL (DPLL\_USB\_OTG\_SS)

For more information, see section *SuperSpeed USB DRD (USB)* in chapter *Serial Communication Interfaces* of the device TRM.

### 6.13.10 PCIe

The Peripheral Component Interconnect Express (PCIe) module is a multi-lane I/O interconnect that provides low pin-count, high reliability, and high-speed data transfer at rates of up to 5.0 Gbps per lane, per direction, for serial links on backplanes and printed wiring boards. It is a 3-rd Generation I/O Interconnect technology succeeding PCI and ISA bus that is designed to be used as a general-purpose serial I/O interconnect. It is also used as a bridge to other interconnects like USB2/3.0, GbE MAC, and so forth.

The PCI Express standard predecessor - PCI, is a parallel bus architecture that is increasingly difficult to scale-up in bandwidth, which is usually performed by increasing the number of data signal lines. The PCIe architecture was developed to help minimize I/O bus bottlenecks within systems and to provide the necessary bandwidth for high-speed, chip-to-chip, and board-to-board communications within a system. It is designed to replace the PCI-based shared, parallel bus signaling technology that is approaching its practical performance limits while simplifying the interface design.

The device instantiates two PCIe subsystems (PCIe\_SS1 and PCIe\_SS2). The PCIe controller is capable to operate either in Root Complex (RC) or in End Point (EP) PCIe mode. The device PCIe\_SS1 controller supports up to two 16-bit data lanes on its PIPE port. The device PCIe\_SS2 controller supports only one 16-bit data lane on its PIPE port.

When the PCIe\_SS1 controller PIPE port is configured to operate in a single-lane mode, it operates on a single pair of PCIe PHY serializer and deserializer - PCIe1\_PHY\_TX/PCIe1\_PHY\_RX. When PCIe\_SS1 PIPE is configured to operate in dual-lane mode, it operates on two pairs of PCIe PHY serializer and deserializer - PCIe1\_PHY\_TX/PCIe1\_PHY\_RX and PCIe2\_PHY\_TX/PCIe2\_PHY\_RX, respectively. The single-lane PCIe\_SS2 controller PIPE port (if enabled) can operate only on the PCIe2\_PHY\_TX/PCIe2\_PHY\_RX pair. Hereby, if PCIe\_SS2 controller is used, the PCIe\_SS1 can operate only in a single-lane mode on the PCIe1\_PHY\_TX/PCIe1\_PHY\_RX. In addition, PCIe PHY subsystem encompasses a PCIe PCS (physical coding sublayer), a PCIe power management logic, APLL, a DPLL reference clock generator and an APLL clock low-jitter buffer.

- The PCIe Controller implements the transport and link layers of the PCIe interface protocol.
- PCIe PCS (a physical coding sublayer component) converts a 8-bit portion of parallel data over a PCIe lane to a 10-bit parallel data to adapt the process of serialization and deserialization in the TX/RX PHYs to various requirements. At the same time it transforms the transmission rate to maintain the PCIe Gen2 bandwidth (5 Gbps) on both sides (PCIe controller and PHY).
- A multiplexer logic which adds flexibility to connect a PCIe controller hardware mapped PCS logic output to a single (for the single-lane PCIe\_SS2 controller) or to a couple (for the 2-lane PCIe\_SS1 controller) of PHY ports at a time
- Physical layer (PHY) serializer/deserializer components with associated power control logic, building the so called PMA (physical media attachment) part of the PCIe\_PHY transceiver, as follows:
  - PCIe physical port 0 associated serializer (TX) - PCIe1\_PHY\_TX and deserializer (RX) - PCIe1\_PHY\_RX
  - PCIe physical port 1 associated serializer (TX) - PCIe2\_PHY\_TX and deserializer (RX) - PCIe2\_PHY\_RX
- DPLL\_PCIe\_REF is a DPLL clock source, controlled from the device PRCM, that provides a 100-MHz clock to the PCIe PHY serializer/deserializer components reference clock inputs.
- Both the PCIe\_SS1 and PCIe\_SS2 share the same APLL (APLLPCIe) which by default multiplies the DPLL\_PCIe\_REF (typically 100 MHz or 20 MHz) clock to 2.5 GHz.
- The APLLPCIe low-jitter buffer (ACSPCIE) and additional logic takes care to provide the PCIe APLL reference input clock.

PCIe module supports the following features:

- PCI Local Bus Specification revision 3.0
- PCI Express Base 3.0 Specification, revision 1.0.

**At system level the device supports PCI express interface in the following configurations:**

- Each PCIe subsystem controller has support for PCIe Gen2 mode (5.0 Gbps per lane) and Gen1 mode (2.5 Gbps per lane).
- One PCIe (PCIe\_SS1) operates as Gen2 2-lanes supporting in either root-complex (RC) or end-point EP.
- Two PCIe (PCIe\_SS1 and PCIe\_SS2) operates Gen2 1-lane supporting either RC or EP with the possibility of one operating in Gen1 and one in Gen2.



- PCIe\_SS1 can be configured to operate in either 2-Lane (dual lane) or 1-Lane (single lane) mode, as follows:
  - Single Lane - lane 0 mapped to the PCIe port 0 of the device
  - Flexible dual lane configuration - lanes 0 and 1 can be swapped on the two PCIe ports
- PCIe\_SS2 can only operate in 1-Lane mode, as follows:
  - Single Lane - lane 0 mapped to the device PCIe port 1
 When PCIe\_SS1 is configured to operate in dual-lane mode, PCIe\_SS2 is in-operable as both PCIe1\_PHY\_RX/TX and PCIe2\_PHY\_RX/TX are assigned to PCIe\_SS1, and thereby NOT available to PCIe\_SS2.

**The main features of a device PCIe controller are:**

- 16-bit operation at 250 MHz on PIPE interface (per 16-bit lane)
- One master port on the L3\_MAIN supporting 32-bit address and 64-bit data bus.
- PCIe\_SS1 master port dedicated MMU (device MMU2) on L3\_MAIN path, to which PCIe traffic can be optionally mapped.
- One slave port on the L3\_MAIN supporting 29-bit address and 64-bit data bus.
- Maximum outbound payload size of 64 Bytes (the L3 Interconnect PCIe1/2 target ports split bursts of size >64 Bytes to the into multiple 64 Byte bursts)
- Maximum inbound payload size of 256 Bytes (internally converted to 128 Byte - bursts)
- No remote read request size limit: implicit support for 4 KiB-size and greater
- Support of EP legacy mode
- Support of inbound I/O accesses in EP legacy mode
- PIPE interface features fixed-width (16-bit data per lane) and dynamic frequency to switch between PCIe Gen1 and Gen2.
- Ultra-low transmit and receive latency
- Automatic Lane reversal as specified in the PCI Express Base 3.0 Specification, revision 1.0 (transmit and receive)
- Polarity inversion on receive
- Single Virtual Channel (VC0) and Single Traffic Class (TC0)
- Single Function in End point mode
- Automatic credit management
- ECRC generation and checking
- All PCI Device Power Management D-states with the exception of D3<sub>cold</sub>/L2 state
- PCI Express Active State Power Management (ASPM) state L0s and L1 (with exceptions)
- PCI Express Link Power Management states except for L2 state
- PCI Express Advanced Error Reporting (AER)
- PCI Express messages for both transmit and receive
- Filtering for Posted, Non-Posted, and Completion traffic
- Configurable BAR filtering, I/O filtering, configuration filtering and completion lookup/timeout
- Access to configuration space registers and external application memory mapped registers through ECAM mechanism.
- Legacy PCI Interrupts reception (RC) and generation (EP)
- 2 x hardware interrupts per PCIe\_SS1 and PCIe\_SS2 controller mapped via the device Interrupt Crossbar (IRQ\_CROSSBAR) to multiple device host (MPU, DSP, and so forth) interrupt controllers in the device
- MSIs generation and reception
- PCIe\_PHY Loopback in RC mode

For more information, see section *PCIe Controller* in chapter *Serial Communication Interfaces* of the device TRM.

### 6.13.11 DCAN

The Controller Area Network (CAN) is a serial communications protocol which efficiently supports distributed real-time applications. CAN has high immunity to electrical interference and the ability to self-diagnose and repair data errors. In a CAN network, many short messages are broadcast to the entire network, which provides for data consistency in every node of the system.

The device provides two DCAN interfaces for supporting distributed realtime control with a high level of security. The DCAN interfaces implement the following features:

- Supports CAN protocol version 2.0 part A, B
- Bit rates up to 1 MBit/s
- 64 message objects
- Individual identifier mask for each message object
- Programmable FIFO mode for message objects
- Programmable loop-back modes for self-test operation
- Suspend mode for debug support
- Software module reset
- Automatic bus on after Bus-Off state by a programmable 32-bit timer
- Direct access to Message RAM during test mode
- CAN Rx/Tx pins are configurable as general-purpose IO pins
- Two interrupt lines (plus additional parity-error interrupts line)
- RAM initialization
- DMA support

For more information, see section *Controller Area Network Interface (DCAN)* in chapter *Serial Communication Interfaces* of the device TRM.

### 6.13.12 GMAC\_SW

The three-port gigabit ethernet switch subsystem (GMAC\_SW) provides ethernet packet communication and can be configured as an ethernet switch. It provides the gigabit media independent interface (G/MII) in MII mode, reduced gigabit media independent interface (RGMII), reduced media independent interface (RMII), and the management data input output (MDIO) for physical layer device (PHY) management.

The GMAC\_SW subsystem provides the following features:

- Two Ethernet ports (port 1 and port 2) with selectable RGMII, RMII, and G/MII (in MII mode only) interfaces plus internal Communications Port Programming Interface (CPPI 3.1) on port 0
- Synchronous 10/100/1000 Mbit operation
- Wire rate switching (802.1d)
- Non-blocking switch fabric
- Flexible logical FIFO-based packet buffer structure
- Four priority level Quality Of Service (QOS) support (802.1p)
- CPPI 3.1 compliant DMA controllers
- Support for Audio/Video Bridging (P802.1Qav/D6.0)
- Support for IEEE 1588 Clock Synchronization (2008 Annex D and Annex F)
  - Timing FIFO and time stamping logic embedded in the subsystem
- Device Level Ring (DLR) Support
- Energy Efficient Ethernet (EEE) support (802.3az)
- Flow Control Support (802.3x)

- Address Lookup Engine (ALE)
  - 1024 total address entries plus VLANs
  - Wire rate lookup
  - Host controlled time-based aging
  - Multiple spanning tree support (spanning tree per VLAN)
  - L2 address lock and L2 filtering support
  - MAC authentication (802.1x)
  - Receive-based or destination-based multicast and broadcast rate limits
  - MAC address blocking
  - Source port locking
  - OUI (Vendor ID) host accept/deny feature
  - Remapping of priority level of VLAN or ports
- VLAN support
  - 802.1Q compliant
    - Auto add port VLAN for untagged frames on ingress
    - Auto VLAN removal on egress and auto pad to minimum frame size
- Ethernet Statistics:
  - EtherStats and 802.3Stats Remote network Monitoring (RMON) statistics gathering (shared)
  - Programmable statistics interrupt mask when a statistic is above one half its 32-bit value
- Flow Control Support (802.3x)
- Digital loopback and FIFO loopback modes supported
- Maximum frame size 2016 bytes (2020 with VLAN)
- 8k (2048 × 32) internal CPPI buffer descriptor memory
- Management Data Input/Output (MDIO) module for PHY Management
- Programmable interrupt control with selected interrupt pacing
- Emulation support
- Programmable Transmit Inter Packet Gap (IPG)
- Reset isolation (switch function remains active even in case of all device resets except for POR pin reset and ICEPICK cold reset)
- Full duplex mode supported in 10/100/1000 Mbps. Half-duplex mode supported only in 10/100 Mbps.
- IEEE 802.3 gigabit Ethernet conformant

For more information, see section *Gigabit Ethernet Switch (GMAC\_SW)* in chapter *Serial Communication Interfaces* of the device TRM.

### 6.13.13 eMMC/SD/SDIO

The eMMC/SD/SDIO host controller provides an interface between a local host (LH) such as a microprocessor unit (MPU) or digital signal processor (DSP) and either eMMC, SD® memory cards, or SDIO cards and handles eMMC/SD/SDIO transactions with minimal LH intervention.

Optionally, the controller is connected to the L3\_MAIN interconnect to have a direct access to system memory. It also supports two direct memory access (DMA) slave channels or a DMA master access (in this case, slave DMA channels are deactivated) depending on its integration.

The eMMC/SD/SDIO host controller deals with eMMC/SD/SDIO protocol at transmission level, data packing, adding cyclic redundancy checks (CRCs), start/end bit, and checking for syntactical correctness.

The application interface can send every eMMC/SD/SDIO command and poll for the status of the adapter or wait for an interrupt request, which is sent back in case of exceptions or to warn of end of operation.

The application interface can read card responses or flag registers. It can also mask individual interrupt sources. All these operations can be performed by reading and writing control registers. The eMMC/SD/SDIO host controller also supports two DMA channels.

There are four eMMC/SD/SDIO host controllers inside the device. gives an overview of the eMMC/SD/SDIO<sub>i</sub> (i = 1 to 4) controllers.

Each controller has the following data width:

- eMMC/SD/SDIO1 - 4-bit wide data bus
- eMMC/SD/SDIO2 - 8-bit wide data bus
- eMMC/SD/SDIO3 - 4-bit wide data bus
- eMMC/SD/SDIO4 - 4-bit wide data bus

The eMMC/SD/SDIO<sub>i</sub> controller is also referred to as MMC<sub>i</sub>.

Compliance with standards:

- Full compliance with MMC/eMMC command/response sets as defined in the JC64 MMC/eMMC standard specification, v4.5.
- Full compliance with SD command/response sets as defined in the SD Physical Layer specification v3.01
- Full compliance with SDIO command/response sets and interrupt/read-wait suspend-resume operations as defined in the SD part E1 specification v3.00
- Full compliance with SD Host Controller Standard Specification sets as defined in the SD card specification Part A2 v3.00

Main features of the eMMC/SD/SDIO host controllers:

- Flexible architecture allowing support for new command structure
- 32-bit wide access bus to maximize bus throughput
- Designed for low power
- Programmable clock generation
- Dedicated DLL to support SDR104 mode (MMC1 only)
- Dedicated DLL to support HS200 mode (MMC2 only)
- Card insertion/removal detection and write protect detection
- L4 slave interface supports:
  - 32-bit data bus width
  - 8/16/32 bit access supported
  - 9-bit address bus width
  - Streaming burst supported only with burst length up to 7
  - WNP supported
- L3 initiator interface Supports:
  - 32-bit data bus width
  - 8/16/32 bit access supported
  - 32-bit address bus width
  - Burst supported
- Built-in 1024-byte buffer for read or write
- Two DMA channels, one interrupt line
- Support JC 64 v4.4.1 boot mode operations
- Support SDA 3.00 Part A2 programming model
- Support SDA 3.00 Part A2 DMA feature (ADMA2)

- Supported data transfer rates:
  - MMCi supports the following SD v3.0 data transfer rates:
    - DS mode (3.3V IOs): up to 12 MBps (24 MHz clock)
    - HS mode (3.3V IOs): up to 24 MBps (48 MHz clock)
    - SDR12 (1.8V IOs): up to 12 MBps (24 MHz clock)
    - SDR25 (1.8V IOs): up to 24 MBps (48 MHz clock)
    - SDR50 (1.8V IOs): up to 48 MBps (96 MHz clock) - MMC1 and MMC3 only
    - DDR50 (1.8V IOs): up to 48 MBps (48 MHz clock) - MMC1 only
    - SDR104 (1.8V IOs) cards can be supported up to 192 MHz clock (96 MBps max) - MMC1 only
  - MMCi supports the Default SD mode 1-bit data transfer up to 24Mbps (3MBps)
  - Only MMC2 supports also the following JC64 v4.5 data transfer rates:
    - Up to 192 MBps in eMMC mode, 8-bit SDR mode (192 MHz clock frequency)
    - Up to 96 MBps in eMMC mode, 8-bit DDR mode (48 MHz clock frequency)
- All eMMC/SD/SDIO controllers are connected to 1,8V/3.3V compatible I/Os to support 1,8V/3.3V signaling

---

**NOTE**

eMMC functionality is supported fully by MMC2 only. The other MMC modules are capable of eMMC functionality, but are not timing-optimized for eMMC.

---

The differences between the eMMC/SD/SDIO host controllers and a standard SD host controller defined by the *SD Card Specification, Part A2, SD Host Controller Standard Specification, v3.00* are:

- The clock divider in the eMMC/SD/SDIO host controller supports a wider range of frequency than specified in the *SD Memory Card Specifications, v3.0*. The eMMC/SD/SDIO host controller supports odd and even clock ratio.
- The eMMC/SD/SDIO host controller supports configurable busy time-out.
- ADMA2 64-bit mode is not supported.
- There is no external LED control.

---

**NOTE**

Only even ratios are supported in DDR mode.

---

For more information, see chapter *eMMC/SD/SDIO* of the device TRM.

### 6.13.14 GPIO

The general-purpose interface combines eight general-purpose input/output (GPIO) banks.

Each GPIO module provides 32 dedicated general-purpose pins with input and output capabilities; thus, the general-purpose interface supports up to 186 pins.

These pins can be configured for the following applications:

- Data input (capture)/output (drive)
- Keyboard interface with a debounce cell
- Interrupt generation in active mode upon the detection of external events. Detected events are processed by two parallel independent interrupt-generation submodules to support biprocessor operations.
- Wake-up request generation in idle mode upon the detection of external events

For more information, see section *General-Purpose Interface (GPIO)* of the device TRM.

### 6.13.15 ePWM

An effective PWM peripheral must be able to generate complex pulse width waveforms with minimal CPU overhead or intervention. It needs to be highly programmable and very flexible while being easy to understand and use. The ePWM unit described here addresses these requirements by allocating all needed timing and control resources on a per PWM channel basis. Cross coupling or sharing of resources has been avoided; instead, the ePWM is built up from smaller single channel modules with separate resources and that can operate together as required to form a system. This modular approach results in an orthogonal architecture and provides a more transparent view of the peripheral structure, helping users to understand its operation quickly.

Each ePWM module supports the following features:

- **Dedicated 16-bit time-base counter with period and frequency control**
- **Two PWM outputs (EPWMxA and EPWMxB) that can be used in the following configurations:**
  - Two independent PWM outputs with single-edge operation
  - Two independent PWM outputs with dual-edge symmetric operation
  - One independent PWM output with dual-edge asymmetric operation
- **Asynchronous override control of PWM signals through software.**
- **Programmable phase-control support for lag or lead operation relative to other ePWM modules.**
- **Hardware-locked (synchronized) phase relationship on a cycle-by-cycle basis.**
- **Dead-band generation with independent rising and falling edge delay control.**
- **Programmable trip zone allocation of both cycle-by-cycle trip and one-shot trip on fault conditions.**
- **A trip condition can force either high, low, or high-impedance state logic levels at PWM outputs.**
- **Programmable event prescaling minimizes CPU overhead on interrupts.**
- **PWM chopping by high-frequency carrier signal, useful for pulse transformer gate drives.**

For more information, see section *Enhanced PWM (ePWM) Module* in chapter *Pulse-Width Modulation Subsystem* of the device TRM.

### 6.13.16 eCAP

Uses for eCAP include:

- Sample rate measurements of audio inputs
- Speed measurements of rotating machinery (for example, toothed sprockets sensed via Hall sensors)
- Elapsed time measurements between position sensor pulses
- 4 stage sequencer (Mod4 counter) which is synchronized to external events (ECAPx pin edges)

- Period and duty cycle measurements of pulse train signals
- Decoding current or voltage amplitude derived from duty cycle encoded current/voltage sensors

The eCAP module includes the following features:

- 32-bit time base counter
- 4-event time-stamp registers (each 32 bits)
- Edge polarity selection for up to four sequenced time-stamp capture events
- Interrupt on either of the four events
- Single shot capture of up to four event time-stamps
- Continuous mode capture of time-stamps in a four-deep circular buffer
- Absolute time-stamp capture
- Difference (Delta) mode time-stamp capture
- All above resources dedicated to a single input pin
- When not used in capture mode, the ECAP module can be configured as a single channel PWM output

For more information, see section *Enhanced Capture (eCAP) Module* in chapter *Pulse-Width Modulation Subsystem* of the device TRM.

### 6.13.17 eQEP

A single track of slots patterns the periphery of an incremental encoder disk, as shown in [Figure 6-2](#). These slots create an alternating pattern of dark and light lines. The disk count is defined as the number of dark/light line pairs that occur per revolution (lines per revolution). As a rule, a second track is added to generate a signal that occurs once per revolution (index signal: QEPI), which can be used to indicate an absolute position. Encoder manufacturers identify the index pulse using different terms such as index, marker, home position, and zero reference.

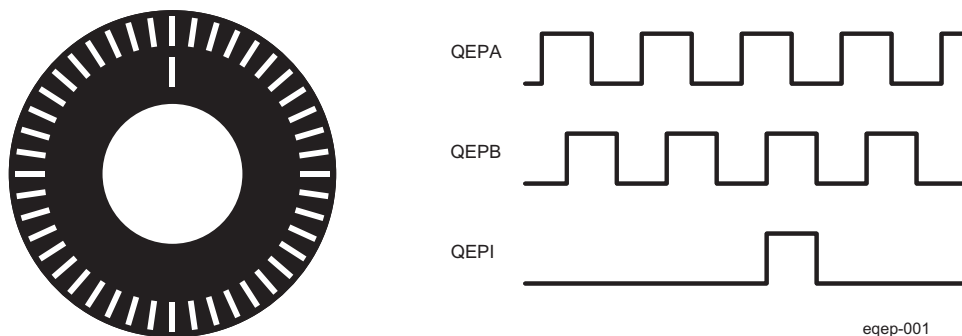

**Figure 6-2. Optical Encoder Disk**

To derive direction information, the lines on the disk are read out by two different photo-elements that "look" at the disk pattern with a mechanical shift of 1/4 the pitch of a line pair between them. This shift is realized with a reticle or mask that restricts the view of the photo-element to the desired part of the disk lines. As the disk rotates, the two photo-elements generate signals that are shifted 90 degrees out of phase from each other. These are commonly called the quadrature QEPA and QEPB signals. The clockwise direction for most encoders is defined as the QEPA channel going positive before the QEPB channel.

The encoder wheel typically makes one revolution for every revolution of the motor or the wheel may be at a geared rotation ratio with respect to the motor. Therefore, the frequency of the digital signal coming from the QEPA and QEPB outputs varies proportionally with the velocity of the motor. For example, a 2000-line encoder directly coupled to a motor running at 5000 revolutions per minute (rpm) results in a frequency of 166.6 KHz, so by measuring the frequency of either the QEPA or QEPB output, the processor can determine the velocity of the motor.

For more information, see section *Enhanced Quadrature Encoder Pulse (eQEP) Module* in chapter *Pulse-Width Modulation Subsystem* of the device TRM.

## 6.14 On-chip Debug

Debugging a system that contains an embedded processor involves an environment that connects high-level debugging software running on a host computer to a low-level debug interface supported by the target device. Between these levels, a debug and trace controller (DTC) facilitates communication between the host debugger and the debug support logic on the target chip.

The DTC is a combination of hardware and software that connects the host debugger to the target system. The DTC uses one or more hardware interfaces and/or protocols to convert actions dictated by the debugger user to JTAG<sup>®</sup> commands and scans that execute the core hardware.

The debug software and hardware components let the user control multiple central processing unit (CPU) cores embedded in the device in a global or local manner. This environment provides:

- Synchronized global starting and stopping of multiple processors
- Starting and stopping of an individual processor
- Each processor can generate triggers that can be used to alter the execution flow of other processors

System topics include but are not limited to:

- System clocking and power-down issues
- Interconnection of multiple devices
- Trigger channels

For more information, see chapter *On-chip Debug* of the device TRM.

The device deploys Texas Instrument's CTools debug technology for on-chip debug and trace support. It provides the following features:

- External debug interfaces:
  - Primary debug interface - IEEE1149.1 (JTAG) or IEEE1149.7 (complementary superset of JTAG)
    - Used for debugger connection
    - Default mode is IEEE1149.1 but debugger can switch to IEEE1149.7 via an IEEE1149.7 adapter module
    - Controls ICEPick (generic test access port [TAP] for dynamic TAP insertion) to allow the debugger to access several debug resources through its secondary (output) JTAG ports (for more information, see *ICEPick Secondary TAPs* section of the Device TRM).
  - Debug (trace) port
    - Can be used to export processor or system trace off-chip (to an external trace receiver)
    - Can be used for cross-triggering with an external device
    - Configured through debug resources manager (DRM) module instantiated in the debug subsystem
    - For more information about debug (trace) port, see *Debug (Trace) Port* and *Concurrent Debug Modes* sections of the Device TRM.
- JTAG based processor debug on:
  - Cortex-A15 in MPU
  - C66x in DSP1
  - Cortex-M4 (x2) in IPU1, IPU2
  - Arm968 (x2) in IVA
- Dynamic TAP insertion
  - Controlled by ICEPick
  - For more information, see , *Dynamic TAP Insertion*.



- Power and clock management
  - Debugger can get the status of the power domain associated to each TAP.
  - Debugger may prevent the application software switching off the power domain.
  - Application power management behavior can be preserved during debug across power transitions.
  - For more information, see *Power and Clock Management* section of the Device TRM.
- Reset management
  - Debugger can configure ICEPick to assert, block, or extend the reset of a given subsystem.
  - For more information, see *Reset Management* section of the Device TRM.
- Cross-triggering
  - Provides a way to propagate debug (trigger) events from one processor, subsystem, or module to another:
    - Subsystem A can be programmed to generate a debug event, which can then be exported as a global trigger across the device.
    - Subsystem B can be programmed to be sensitive to the trigger line input and to generate an action on trigger detection.
  - Two global trigger lines are implemented
  - Device-level cross-triggering is handled by the XTRIG (TI cross-trigger) module implemented in the debug subsystem
  - Various Arm® CoreSight™ cross-trigger modules implemented to provide support for CoreSight triggers distribution
    - CoreSight Cross-Trigger Interface (CS\_CTI) modules
    - CoreSight Cross-Trigger Matrix (CS\_CTM) modules
  - For more information about cross-triggering, see *Cross-Triggering* section of the Device TRM.
- Suspend
  - Provides a way to stop a closely coupled hardware process running on a peripheral module when the host processor enters debug state
  - For more information about suspend, see *Suspend* section of the Device TRM.
- MPU watchpoint
  - Embedded in MPU subsystem
  - Provides visibility on MPU to EMIF direct paths
  - For more information, see *MPU Memory Adaptor (MPU\_MA) Watchpoint* section of the Device TRM.
- Processor trace
  - Cortex-A15 (MPU) and C66x (DSP) processor trace is supported
  - Program trace only for MPU (no data trace)
  - MPU trace supported by a CoreSight Program Trace Macrocell (CS\_PTM) module
  - Three exclusive trace sinks:
    - CoreSight Trace Port Interface Unit (CS\_TPIU) – trace export to an external trace receiver
    - CTools Trace Buffer Router (CT\_TBR) in system bridge mode – trace export through USB
    - CT\_TBR in buffer mode – trace history store into on-chip trace buffer
  - For more information, see *Processor Trace* section of the Device TRM.

- System instrumentation (trace)
  - Supported by a CTools System Trace Module (CT\_STM), implementing MIPI System Trace Protocol (STP) (rev 2.0)
  - Real-time software trace
    - MPU software instrumentation through CoreSight STM (CS\_STM) (STP2.0)
    - System-on-chip (SoC) software instrumentation through CT\_STM (STP2.0)
  - OCP watchpoint (OCP\_WP\_NOC)
    - OCP target traffic monitoring: OCP\_WP\_NOC can be configured to generate a trigger upon watchpoint match (that is, when target transaction attributes match the user-defined attributes).
    - SoC events trace
    - DMA transfer profiling
  - Statistics collector (performance probes)
    - Computes traffic statistics within a user-defined window and periodically reports to the user through the CT\_STM interface
    - Embedded in the L3\_MAIN interconnect
    - 10 instances:
      - 1 instance dedicated to target (SDRAM) load monitoring
      - 9 instances dedicated to master latency monitoring
  - IVA instrumentation (hardware accelerator [HWA] profiling)
    - Supported through a software message and system trace event (SMSET) module embedded in the IVA subsystem
  - Power-management events profiling (PM instrumentation [PMI])
    - Monitoring major power-management events. The PM state changes are handled as generic events and encapsulated in STP messages.
  - Clock-management events profiling (CM instrumentation [CMI])
    - Monitoring major clock management events. The CM state changes are handled as generic events and encapsulated in STP messages.
    - Two instances, one per CM
      - CM1 Instrumentation (CMI1) module mapped in the PD\_CORE\_AON power domain
      - CM2 Instrumentation (CMI2) module mapped in the PD\_CORE power domain
  - For more information, see *System Instrumentation* section of the Device TRM.
- Performance monitoring
  - Supported by subsystem counter timer module (SCTM) for IPU
  - Supported by performance monitoring unit (PMU) for MPU subsystem

For more information, see chapter *On-Chip Debug Support* of the device TRM.

## 7 Applications, Implementation, and Layout

---

### NOTE

Information in the following Applications section is not part of the TI component specification, and TI does not warrant its accuracy or completeness. TI's customers are responsible for determining suitability of components for their purposes. Customers should validate and test their design implementation to confirm system functionality.

---

### 7.1 Introduction

This chapter is intended to communicate, guide and illustrate a PCB design strategy resulting in a PCB that can support TI's latest Application Processor. This Processor is a high-performance processor designed for automotive Infotainment based on enhanced OMAP™ architecture integrated on a 28-nm CMOS process technology.

These guidelines first focus on designing a robust Power Delivery Network (PDN) which is essential to achieve the desirable high performance processing available on Device. The general principles and step-by-step approach for implementing good power integrity (PI) with specific requirements will be described for the key Device power domains.

TI strongly believes that simulating a PCB's proposed PDN is required for first pass PCB design success. Key Device processor high-current power domains need to be evaluated for Power Rail IR Drop, Decoupling Capacitor Loop-Inductance and Power Rail Target Impedance. Only then can a PCB's PDN performance be truly accessed by comparing these model PI parameters vs. TI's recommended values. Ultimately for any high-volume product, TI recommends conducting a "Processor PDN Validation" test on prototype PCBs across processor "split lots" to verify PDN robustness meets desired performance goals for each customer's worst-case scenario. Please contact your TI representative to receive guidance on PDN PI modeling and validation testing.

Likewise, the methodology and requirements needed to route Device high-speed, differential interfaces (i.e. USB2.0, USB3.0, HDMI, PCI), single-ended interfaces (i.e. DDR3, QSPI) and general purpose interfaces using LVCMOS drivers that meet timing requirements while minimizing signal integrity (SI) distortions on the PCB's signaling traces. Signal trace lengths and flight times are aligned with FR-4 standard specification for PCBs.

Several different PCB layout stack-up examples have been presented to illustrate a typical number of layers, signal assignments and controlled impedance requirements. Different Device interface signals demand more or less complexity for routing and controlled impedance stack-ups. Optimizing the PCB's PDN stack-up needs with all of these different types of signal interfaces will ultimately determine the final layer count and layer assignments in each customer's PCB design.

This guideline must be used as a supplement in complement to TI's Application Processor, Power Management IC (PMIC) and Audio Companion components along with other TI component technical documentation (i.e. Technical Reference Manual, Data Manual, Data Sheets, Silicon Errata, Pin-Out Spreadsheet, Application Notes, etc.).

### NOTE

Notwithstanding any provision to the contrary, TI makes no warranty expressed, implied, or statutory, including any implied warranty of merchantability of fitness for a specific purpose, for customer boards. The data described in this appendix are intended as guidelines only.

---

### NOTE

These PCB guidelines are in a draft maturity and consequently, are subject to change depending on design verification testing conducted during IC development and validation.

---

### 7.1.1 Initial Requirements and Guidelines

Unless otherwise specified, the characteristic impedance for single-ended interfaces is recommended to be between 35  $\Omega$  and 65  $\Omega$  to minimize the overshoot or undershoot on far-end loads.

Characteristic impedance for differential interfaces must be routed as differential traces on the same layer. The trace width and spacing must be chosen to yield the recommended differential impedance. For more information see [Section 7.5.1](#).

The PDN must be optimized for low trace resistance and low trace inductance for all high-current power nets from PMIC to the device.

An external interface using a connector must be protected following the IEC61000-4-2 level 4 system ESD.

## 7.2 Power Optimizations

This section describes the necessary steps for designing a robust Power Distribution Network (PDN):

- [Section 7.2.1, Step 1](#): PCB Stack-up
- [Section 7.2.2, Step 2](#): Physical Placement
- [Section 7.2.3, Step 3](#): Static Analysis
- [Section 7.2.4, Step 4](#): Frequency Analysis

### 7.2.1 Step 1: PCB Stack-up

The PCB stack-up (layer assignment) is an important factor in determining the optimal performance of the power distribution system. An optimized PCB stack-up for higher power integrity performance can be achieved by following these recommendations:

- Power and ground plane pairs must be closely coupled together. The capacitance formed between the planes can decouple the power supply at high frequencies. Whenever possible, the power and ground planes must be solid to provide continuous return path for return current.
- Use a thin dielectric between the power and ground plane pair. Capacitance is inversely proportional to the separation of the plane pair. Minimizing the separation distance (the dielectric thickness) maximizes the capacitance.
- Optimize the power and ground plane pair carrying high current supplies to key component power domains as close as possible to the same surface where these components are placed (see [Figure 7-1](#)). This will help to minimize “loop inductance” encountered between supply decoupling capacitors and component supply inputs and between power and ground plane pairs.

---

#### NOTE

1-2oz Cu weight for power / ground plane is preferred to enable better PCB heat spreading, helping to reduce Processor junction temperatures. In addition, it is preferable to have the power / ground planes be adjacent to the PCB surface on which the Processor is mounted.

---

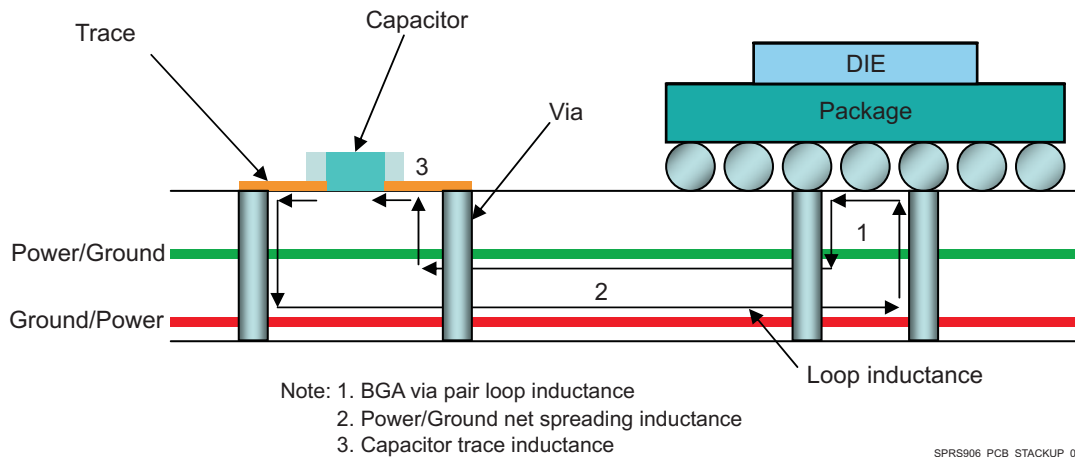

**Figure 7-1. Minimize Loop Inductance With Proper Layer Assignment**

The placement of power and ground planes in the PCB stackup (determined by layer assignment) has a significant impact on the parasitic inductances of power current path as shown in Figure 7-1. For this reason, it is recommended to consider layer order in the early stages of the PCB PDN design cycle, putting high-priority supplies in the top half of the stackup (assuming high load and priority components are mounted on the top-side of PCB) and low-priority supplies in the bottom half of the stackup as shown in the examples below (vias have parasitic inductances which impact the bottom layers more, so it is advised to put the sensitive and high-priority power supplies on the top/same layers).

## 7.2.2 Step 2: Physical Placement

A critical step in designing an optimized PDN is that proper care must be taken to making sure that the initial floor planning of the PCB layout is done with good power integrity design guidelines in mind. The following points are important for optimizing a PCB's PDN:

- Minimizing the physical distance between power sources and key high load components is the first step toward optimization. Placing source and load components on the same side of the PCB is desirable. This will minimize via inductance impact for high current loads and steps
- External trace routing between components must be as wide as possible. The wider the traces, the lower the DC resistance and consequently the lower the static IR drop.
- Whenever possible for the internal layers (routing and plane), wide traces and copper area fills are preferred for PDN layout. The routing of power nets in plane provide for more interplane capacitance and improved high frequency performance of the PDN.
- Whenever possible, use a via to component pin/pad ratio of 1:1 or better (i.e. especially decoupling capacitors, power inductors and current sensing resistors). Do not share vias among multiple capacitors for connecting power supply and ground planes.
- Placement of vias must be as close as possible or even within a component's solder pad if the PCB technology you are using provides this capability.
- To avoid any "ampacity" issue – maximum current-carrying capacity of each transitional via should be evaluated to determine the appropriate number of vias required to connect components.

Adding vias to bring the "via-to-pad" ratio to 1:1 will improve PDN performance.

- For noise sensitive power supplies (i.e. Phase Lock-Loops, analog signals like audio and video), a Gnd shield can be used to isolate coplanar supplies that may have high step currents or high frequency switching transitions from coupling into low-noise supplies.

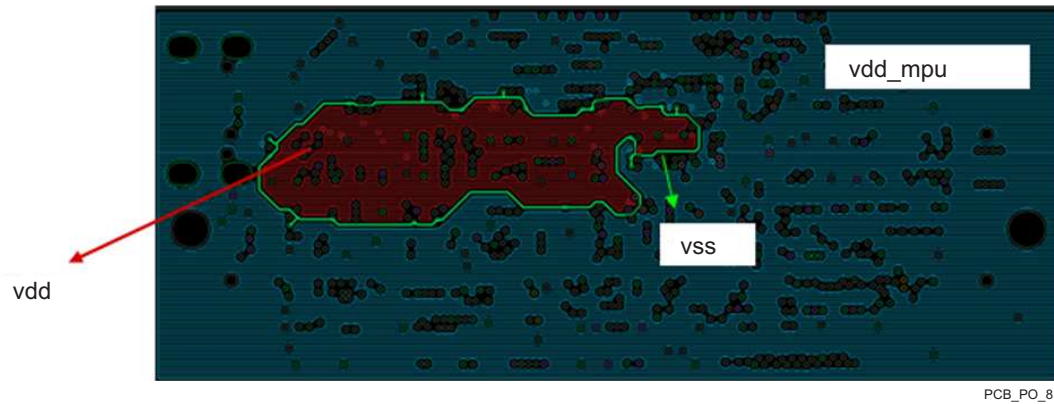

**Figure 7-2. Coplanar Shielding of Power Net Using Ground Guard-band**

### 7.2.3 Step 3: Static Analysis

Delivering reliable power to circuits is always of critical importance because voltage drops (also known as IR drops) can happen at every level within an electronic system, on-chip, within a package, and across the board. Robust system performance can only be ensured by understanding how the system elements will perform under typical stressful Use Cases. Therefore, it is a good practice to perform a Static or DC Analysis.

Static or DC analysis and design methodology results in a PDN design that minimizes voltage or IR drops across power and ground planes, traces and vias. This ensures the application processor's internal transistors will be operating within their specified voltage ranges for proper functionality. The amount of IR drop that will be encountered is based upon amount power drawn for a desired Use Case and PCB trace (widths, geometry and number of parallel traces) and via (size, type and number) characteristics.

Components that are distant from their power source are particularly susceptible to IR drop. Designs that rely on battery power must minimize voltage drops to avoid unacceptable power loss that can negatively impact system performance. Early assessments a PDN's static (DC) performance helps to determine basic power distribution parameters such as best system input power point, optimal PCB layer stackup, and copper area needed for load currents.

The resistance  $R_s$  of a plane conductor for a unit length and unit width is called the **surface resistivity** (ohms per square).

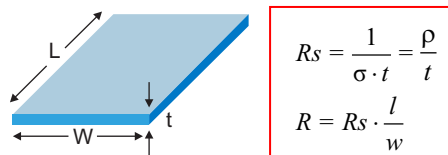

SPRS906\_PCB\_STATIC\_01

**Figure 7-3. Depiction of Sheet Resistivity and Resistance**

Ohm's Law ( $V = I \times R$ ) relates conduction current to voltage drop. At DC, the relation coefficient is a constant and represents the resistance of the conductor. Even current carrying conductors will dissipate power at high currents even though their resistance may be very small. Both voltage drop and power dissipation are proportional to the resistance of the conductor.

Figure 7-4 shows a PCB-level static IR drop budget defined between the power management device (PMIC) pins and the application processor's balls when the PMIC is supplying power.

- It is highly recommended to physically place the PMIC as close as possible to the processor and on the same side. The orientation of the PMIC vs. processor should be aligned to minimize distance for the highest current rail.

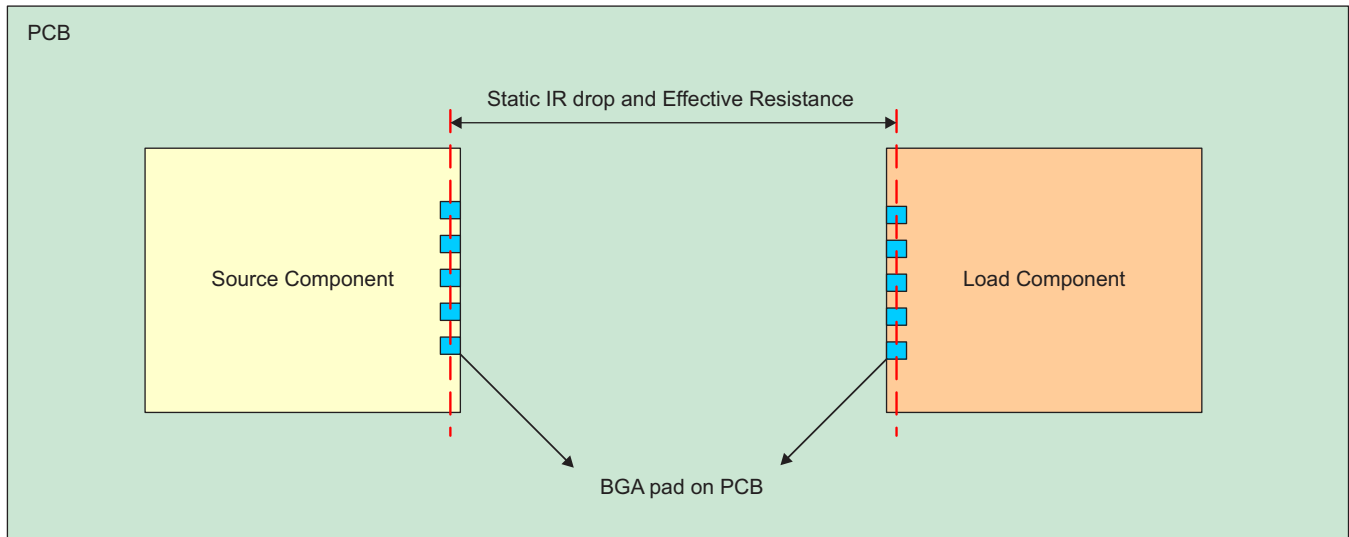

SPRS906\_PCB\_STATIC\_02

**Figure 7-4. Static IR Drop Budget for PCB Only**

The system-level IR drop budget is made up of three portions: on-chip, package, and PCB board. Static IR or DC analysis/design methodology consists of designing the PDN such that the voltage drop (under DC operating conditions) across power and ground pads of the transistors of the application processor device is within a specified value of the nominal voltage for proper functionality of the device.

A PCB system-level voltage drop budget for proper device functionality is typically 1.5% of nominal voltage. For a 1.35-V supply, this would be  $\leq 20$  mV.

To accurately analyze PCB static IR drop, the actual geometry of the PDN must be modeled properly and simulated to accurately characterize long distribution paths, copper weight impacts, electro-migration violations of current-carrying vias, and “Swiss-cheese” effects via placement has on power rails. It is recommended to perform the following analyses:

- Lumped resistance/IR drop analysis
- Distributed resistance/IR drop analysis

#### NOTE

The PMIC companion device supporting this processor has been designed with voltage sensing feedback loop capabilities that enable a remote sense of the SMPS output voltage at the point of use.

The NOTE above means the SMPS feedback signals and returns must be routed across PCB and connected to the Device input power ball for which a particular SMPS is supplying power. This feedback loop provides compensation for some of the voltage drop encountered across the PDN within limits. As such, the effective resistance of the PDN within this loop should be determined in order to optimize voltage compensation loop performance. The resistance of two PDN segments are of interest: one from the power inductor/bulk power filtering capacitor node to the Processor’s input power and second is the entire PDN route from SMPS output pin/ball to the Processor input power.

In the following sections each methodology is described in detail and an example has been provided of analysis flow that can be used by the PCB designer to validate compliance to the requirements on their PCB PDN design.

### 7.2.3.1 PDN Resistance and IR Drop

Lumped methodology consists of grouping all of the power pins on both the PMIC (voltage source) and processor (current sink) devices. Then the PMIC source is set to an expected Use Case voltage level and the processor load has its Use Case current sink value set as well. Now the lumped/effective resistance for the power rail trace/plane routes can be determined based upon the actual layout's power rail etch wide, shape, length, via count and placement [Figure 7-5](#) illustrates the pin-grouping/lumped concept.

The lumped methodology consists of importing the PCB layout database (from Cadence Allegro tool or any other layout design tool) into the static IR drop modeling and simulation tool of preference for the PCB designer. This is followed by applying the correct PCB stack-up information (thickness, material properties) of the PCB dielectric and metallization layers. The material properties of dielectric consist of permittivity (Dk) and loss tangent (Df).

For the conductor layers, the correct conductivity needs to be programmed into the simulation tool. This is followed by pin-grouping of the power and ground nets, and applying appropriate voltage/current sources. The current and voltage information can be obtained from the power and voltage specifications of the device under different operating conditions / Use Cases.

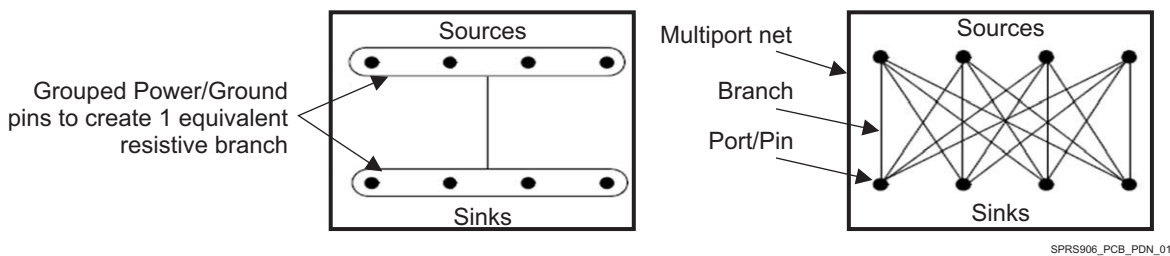

**Figure 7-5. Pin-grouping concept: Lumped and Distributed Methodologies**

### 7.2.4 Step 4: Frequency Analysis

Delivering low noise voltage sources are very important to allowing a system to operate at the lowest possible Operational Performance Point (OPP) for any one Use Case. An OPP is a combination of the supply voltage level and clocking rate for key internal processor domains. A SCH and PCB designed to provide low noise voltage supplies will then enable the processor to enter optimal OPPs for each Use Case that in turn will minimize power dissipation and junction temperatures on-die. Therefore, it is a good engineering practice to perform a Frequency Analysis over the key power domains.

Frequency analysis and design methodology results in a PDN design that minimizes transient noise voltages at the processor's input power balls. This allows the processor's internal transistors to operate near the minimum specified operating supply voltage levels. To accomplish this one must evaluate how a voltage supply will change due to impedance variations over frequency. This analysis will focus on the decoupling capacitor network (VDD\_xxx and VSS/Gnd rails) at the load. Sufficient capacitance with a distribution of self-resonant points will provide for an overall lower impedance vs frequency response for each power domain.

Decoupling components that are distant from their load's input power are susceptible to encountering spreading loop inductance from the PCB design. Early analysis of each key power domain's frequency response helps to determine basic decoupling capacitor placement, optimal footprint, layer assignment, and types needed for minimizing supply voltage noise/fluctuations due to switching and load current transients.

#### NOTE

Evaluation of loop inductance values for decoupling capacitors placed ~300mils closer to the load's input power balls has shown an 18% reduction in loop inductance due to reduced distance.



- Decoupling capacitors must be carefully placed in order to minimize loop inductance impact on supply voltage transients. A real capacitor has characteristics not only of capacitance but also inductance and resistance.

Figure 7-6 shows the parasitic model of a real capacitor. A real capacitor must be treated as an RLC circuit with effective series resistance (ESR) and effective series inductance (ESL).

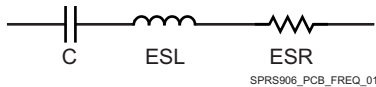

**Figure 7-6. Characteristics of a Real Capacitor With ESL and ESR**

The magnitude of the impedance of this series model is given as:

$$|Z| = \sqrt{ESR^2 + \left(\omega ESL - \frac{1}{\omega C}\right)^2}$$

where :  $\omega = 2\pi f$

SPRS906\_PCB\_FREQ\_02

**Figure 7-7. Series Model Impedance Equation**

Figure 7-8 shows the resonant frequency response of a typical capacitor with a self-resonant frequency of 55 MHz. The impedance of the capacitor is a combination of its series resistance and reactive capacitance and inductance as shown in the equation above.

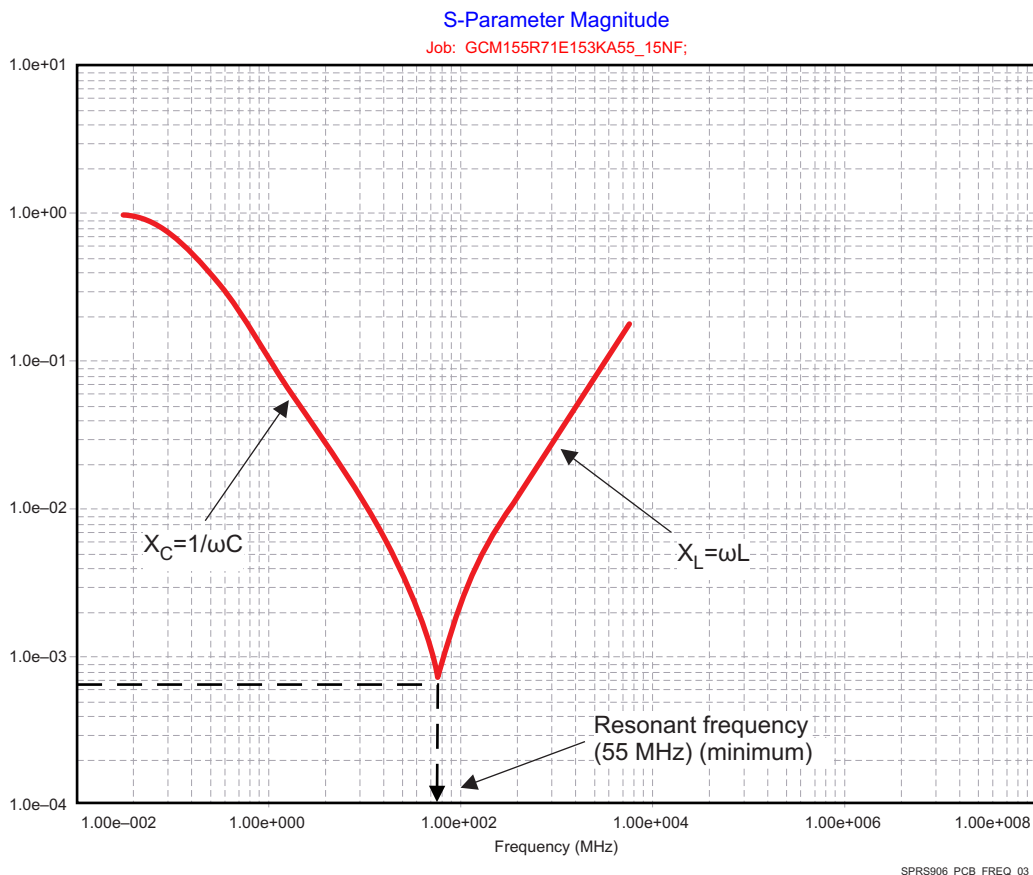

**Figure 7-8. Typical Impedance Profile of a Capacitor**

Because a capacitor has series inductance and resistance that impacts its effectiveness, it is important that the following recommendations are adopted in placing capacitors on the PDN.

Wherever possible, mount the capacitor with the geometry that minimizes the mounting inductance and resistance. This was shown earlier in [Figure 7-1](#). The capacitor mounting inductance and resistance values include the inductance and resistance of the pads, trace, and vias. Whenever possible, use footprints that have the lowest inductance configuration as shown in [Figure 7-9](#)

The length of a trace used to connect a capacitor has a big impact on parasitic inductance and resistance of the mounting. This trace must be as short and as wide as possible. wherever possible, minimize distance to supply and Gnd vias by locating vias nearby or within the capacitor's solder pad landing. Further improvements can be made to the mounting by placing vias to the side of capacitor lands or doubling the number of vias as shown in [Figure 7-9](#). If the PCB manufacturing processes allow it and if cost-effective, via-in-pad (VIP) geometries are strongly recommended.

In addition to mounting inductance and resistance associated with placing a capacitor on the PCB, the effectiveness of a decoupling capacitor also depends on the spreading inductance and resistance that the capacitor sees with respect to the load. The spreading inductance and resistance is strongly dependent on the layer assignment in the PCB stack-up. Therefore, try to minimize X, Y and Z dimensions where the Z is due to PCB thickness (as shown in [Figure 7-9](#)).

From left (highest inductance) to right (lowest inductance) the capacitor footprint types shown in [Figure 7-9](#) are known as:

- 2-via, Skinny End Exit (2vSEE)
- 2-via, Wide End Exit (2vWEE)
- 2-via, Wide Side Exit (2vWSE)
- 4-via, Wide Side Exit (4vWSE)
- 2-via, In-Pad (2vIP)

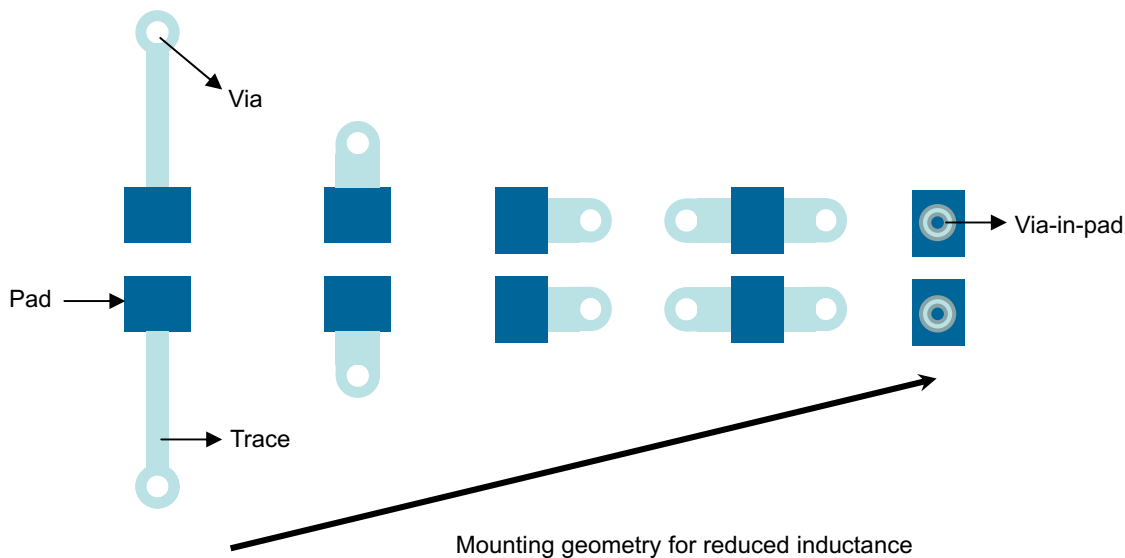

SPRS906\_PCB\_FREQ\_04

**Figure 7-9. Capacitor Placement Geometry for Improved Mounting Inductance**

#### NOTE

Evaluation of loop inductance values for decoupling capacitor footprints 2vSEE (worst case) vs 4vWSE (2nd best) has shown a 30% reduction in inductance when 4vWSE footprint was used in place of 2vSEE.

#### Decoupling Capacitor (Dcap) Strategy:

1. Use lowest inductance footprint and trace connection scheme possible for given PCB technology and layout area in order to minimize Dcap loop inductance to power pin as much as possible (see [Figure 7-9](#)).
2. Place Dcaps on “same-side” as component within their power plane outline to minimize “decoupling loop inductance”. Target distance to power pin should be less than ~500mils depending upon PCB layout characteristics (plane's layer assignment and solid nature). Use PI modeling CAD tool to verify minimum inductance for top vs bottom-side placement.
3. Place Dcaps on “opposite-side” as component within their power plane outline if “same-side” is not feasible or if distance to power pin is greater than ~500mils for top-side location. Use PI modeling CAD tool to verify minimum inductance for top vs bottom-side placement.
4. Use minimum 10mil trace width for all voltage and gnd planes connections (i.e. Dcap pads, component power pins, etc.).
5. Place all voltage and gnd plane vias “as close as possible” to point of use (i.e. Dcap pads, component power pins, etc.).
6. Use a “Power/Gnd pad/pin to via” ratio of 1:1 whenever possible. Do not exceed 2:1 ratio for small number of vias within restricted PCB areas (i.e. underneath BGA components).

Frequency analysis for the CORE power domain has yielded the vdd Impedance vs Frequency response shown in [Section 7.3.8.2](#), vdd Example Analysis. As the example shows the overall CORE PDN  $R_{eff}$  meets the maximum recommended PDN resistance of 10m $\Omega$ .

## 7.2.5 System ESD Generic Guidelines

### 7.2.5.1 System ESD Generic PCB Guideline

Protection devices must be placed close to the ESD source which means close to the connector. This allows the device to subtract the energy associated with an ESD strike before it reaches the internal circuitry of the application board.

To help minimize the residual voltage pulse that will be built-up at the protection device due to its nonzero turn-on impedance, it is mandatory to route the ESD device with minimum stub length so that the low-resistive, low-inductive path from the signal to the ground is granted and not increasing the impedance between signal and ground.

For ESD protection array being railed to a power supply when no decoupling capacitor is available in close vicinity, consider using a decoupling capacitor ( $\geq 0.1 \mu\text{F}$ ) tight to the VCC pin of the ESD protection. A positive strike will be partially diverted to this capacitance resulting in a lower residual voltage pulse.

Ensure that there is sufficient metallization for the supply of signals at the interconnect side (VCC and GND in [Figure 7-10](#)) from connector to external protection because the interconnect may see between 15-A to 30-A current in a short period of time during the ESD event.

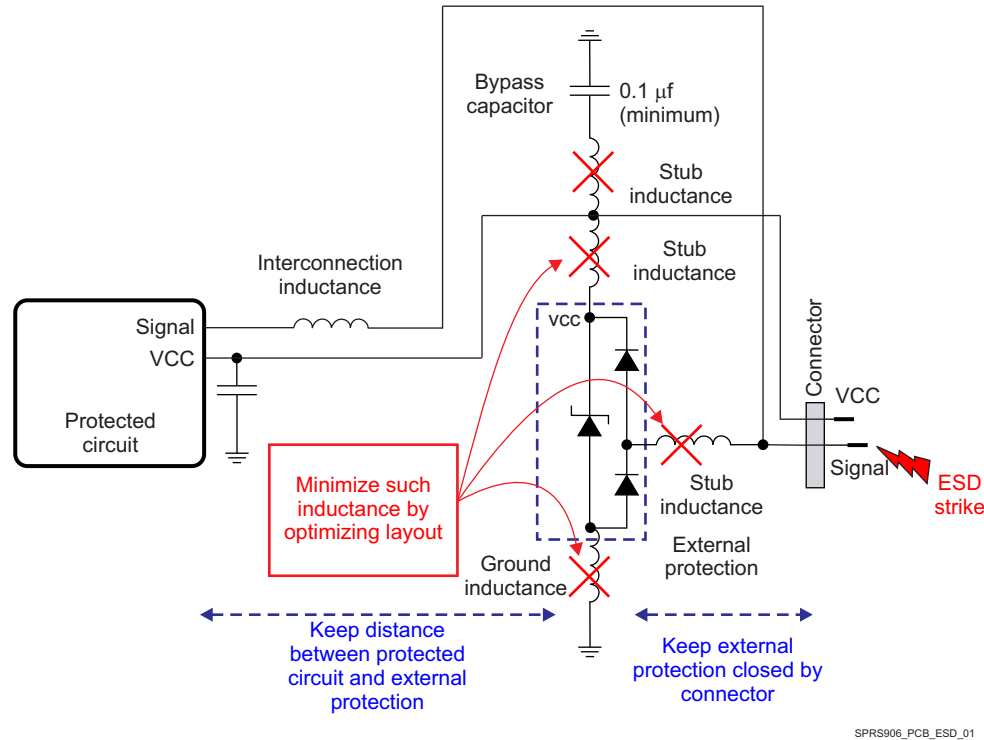

SPRS906\_PCB\_ESD\_01

**Figure 7-10. Placement Recommendation for an ESD External Protection**

**NOTE**

To ensure normal behavior of the ESD protection (unwanted leakage), it is better to ground the ESD protection to the board ground rather than any local ground (example isolated shield or audio ground).

**7.2.5.2 Miscellaneous EMC Guidelines to Mitigate ESD Immunity**

- Avoid running critical signal traces (clocks, resets, interrupts, control signals, and so forth) near PCB edges.
- Add high frequency filtering: Decoupling capacitors close to the receivers rather than close to the drivers to minimize ESD coupling.
- Put a ground (guard) ring around the entire periphery of the PCB to act as a lightning rod.
- Connect the guard ring to the PCB ground plane to provide a low impedance path for ESD-coupled current on the ring.
- Fill unused portions of the PCB with ground plane.
- Minimize circuit loops between power and ground by using multilayer PCB with dedicated power and ground planes.
- Shield long line length (strip lines) to minimize radiated ESD.
- Avoid running traces over split ground planes. It is better to use a bridge connecting the two planes in one area.

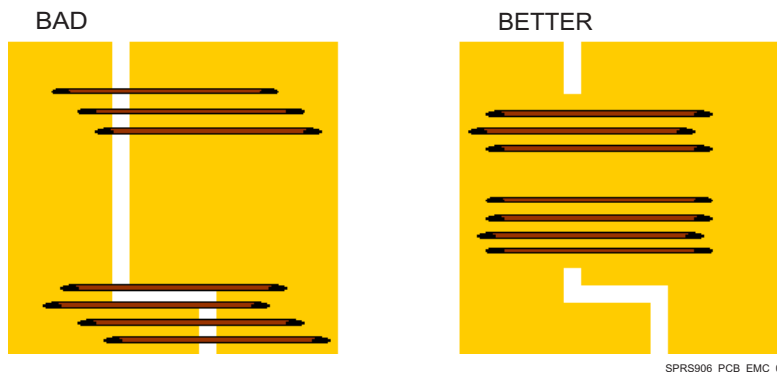

**Figure 7-11. Trace Examples**

- Always route signal traces and their associated ground returns as close to one another as possible to minimize the loop area enclosed by current flow:
  - At high frequencies current follows the path of least inductance.
  - At low frequencies current flows through the path of least resistance.

### 7.2.5.3 ESD Protection System Design Consideration

ESD protection system design consideration is covered in [Section 7.5.2.2](#) of this document. The following are additional considerations for ESD protection in a system.

- Metallic shielding for both ESD and EMI
- Chassis GND isolation from the board GND
- Air gap designed on board to absorb ESD energy
- Clamping diodes to absorb ESD energy
- Capacitors to divert ESD energy
- The use of external ESD components on the DP/DM lines may affect signal quality and are not recommended.

### 7.2.6 EMI / EMC Issues Prevention

All high-speed digital integrated circuits can be sources of unwanted radiation, which can affect nearby sensitive circuitry and cause the final product to have radiated emissions levels above the limits allowed by the EMC regulations if some preventative steps are not taken.

Likewise, analog and digital circuits can be susceptible to interference from the outside world and picked up by the circuitry interconnections.

To minimize the potential for EMI/EMC issues, the following guidelines are recommended to be followed.

#### 7.2.6.1 Signal Bandwidth

To evaluate the frequency of a digital signal, an estimated rule of thumb is to consider its bandwidth  $f_{BW}$  with respect to its rise time,  $t_R$ :

$$f_{BW} \approx 0.35 / t_R$$

This frequency actually corresponds to the break point in the signal spectrum, where the harmonics start to decay at 40 dB per decade instead of 20 dB per decade.

## 7.2.6.2 Signal Routing

### 7.2.6.2.1 Signal Routing—Sensitive Signals and Shielding

Keep radio frequency (RF) sensitive circuitry (like GPS receivers, GSM/WCDMA, Bluetooth/WLAN transceivers, frequency modulation (FM) radio) away from high-speed ICs (the device, power and audio manager, chargers, memories, and so forth) and ideally on the opposite side of the PCB. For improved protection it is recommended to place these emission sources in a shield can. If the shield can have a removable lid (two-piece shield), ensure there is low contact impedance between the fence and the lid. Leave some space between the lid and the components under it to limit the high-frequency currents induced in the lid. Limit the shield size to put any potential shield resonances above the frequencies of interest; see [Figure 7-8](#), *Typical Impedance Profile of a Capacitor*.

### 7.2.6.2.2 Signal Routing—Outer Layer Routing

In case there is a need to use the outer layers for routing outside of shielded areas, it is recommended to route only static signals and ensure that these static signals do not carry any high-frequency components (due to parasitic coupling with other signals). In case of long traces, make provision for a bypass capacitor near the signal source.

Routing of high-frequency clock signals on outer layers, even for a short distance, is discouraged, because their emissions energy is concentrated at the discrete harmonics and can become significant even with poor radiators.

Coplanar shielding of traces on outer layers (placing ground near the sides of a track along its length) is effective only if the distance between the trace sides and the ground is smaller than the trace height above the ground reference plane. For modern multilayer PCBs this is often not possible, so coplanar shielding will not be effective. Do not route high-frequency traces near the periphery of the PCB, as the lack of a ground reference near the trace edges can increase EMI: see [Section 7.2.6.3](#), *Ground Guidelines*.

## 7.2.6.3 Ground Guidelines

### 7.2.6.3.1 PCB Outer Layers

Ideally the areas on the top and bottom layers of the PCB that are not enclosed by a shield should be filled with ground after the routing is completed and connected with an adequate number of vias to the ground on the inner ground planes.

### 7.2.6.3.2 Metallic Frames

Ensure that all metallic parts are well connected to the PCB ground (like LCD screens metallic frames, antennas reference planes, connector cages, flex cables grounds, and so forth). If using flex PCB ribbon cables to bring high-frequency signals off the PCB, ensure they are adequately shielded (coaxial cables or flex ribbons with a solid reference ground).

### 7.2.6.3.3 Connectors

For high-frequency signals going to connectors choose a fully shielded connector, if possible (for example, SD card connectors). For signals going to external connectors or which are routed over long distances, it is recommended to reduce their bandwidth by using low-pass filters (resistor, capacitor (RC) combinations or lossy ferrite inductors). These filters will help to prevent emissions from the board and can also improve the immunity from external disturbances.

### 7.2.6.3.4 Guard Ring on PCB Edges

The major advantage of a multilayer PCB with ground-plane is the ground return path below each and every signal or power trace.

As shown in [Figure 7-12](#) the field lines of the signal return to PCB ground as long as an infinite ground is available.

Traces near the PCB-edges do not have this infinite ground and therefore may radiate more than the others. Thus, signals (clocks) or power traces (core power) identified to be critical must not be routed in the vicinity of PCB edges, or, if not avoidable, must be accompanied by a guard ring on the PCB edge.

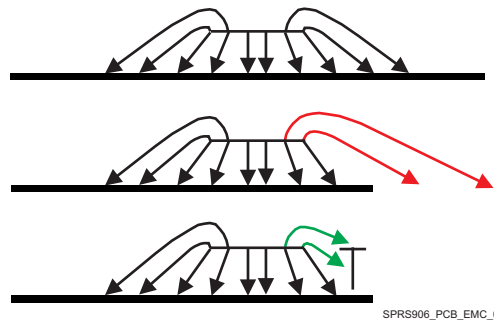

Figure 7-12. Field Lines of a Signal Above Ground



Figure 7-13. Guard Ring Routing

The intention of the guard ring is that HF-energy, that otherwise would have been emitted from the PCB edge, is reflected back into the board where it partially will be absorbed. For this purpose ground traces on the borders of all layers (including power layer) must be applied as shown in [Figure 7-13](#).

As these traces must have the same (HF-) potential as the ground plane they must be connected to the ground plane at least every 10 mm.

#### 7.2.6.3.5 Analog and Digital Ground

For the optimum solution, the AGND and the DGND planes must be connected together at the power supply source in a same point. This ensures that both planes are at the same potential, while the transfer of noise from the digital to the analog domain is minimized.

### 7.3 Core Power Domains

This section provides boundary conditions and theoretical background to be applied as a guide for optimizing a PCB design. The decoupling capacitor and PDN characteristics tables shown below give recommended capacitors and PCB parameters to be followed for schematic and PCB designs. Board designs that meet the static and dynamic PDN characteristics shown in tables below will be aligned to the expected PDN performance needed to optimize SoC performance.

#### 7.3.1 General Constraints and Theory

- Max PCB static/DC voltage drop (IRd) budget of **1.5% of supply voltage** when using TI recommended PMICs **without remote sensing** as measured from PMIC's power inductor and filter capacitor node to Processor input including any ground return losses.
- Max PCB static/DC voltage drop (IRd) budget can be relaxed to **7.5% of supply voltage** when using PMICs **with remote sensing at the load** as measured from PMIC's power inductor and filter capacitor node to Device's supply input including any ground return losses.

- PMIC component DM and guidelines should be referenced for the following:
  - Routing remote feedback sensing to optimize per each SMPS's implementation
  - Selecting power filtering capacitor values and PCB placement.
- Max Effective Resistance (Reff) budget can range from **4 – 100mΩ** for key Device power rails not including ground returns depending upon maximum load currents and maximum DC voltage drop budget (as discussed above).
- Max Device supply input voltage difference budget of **5mV** under max current loading shall be maintained across all balls connected to a common power rail. This represents any voltage difference that may exist between a remote sense point to any power input.
- Max PCB Loop Inductance (LL) budget between Device's power inputs and local bulk and high frequency decoupling capacitors including ground returns should range from **0.4 – 2.5nH depending upon maximum transient load currents.**
- Max PCB dynamic/AC peak-to-peak transient noise voltage budgets between PMIC and Device including ground returns are as follows:
  - **+/-3% of nominal supply voltage** for frequencies below the PMIC bandwidth (typ Fpmic ~ 200kHz)
  - **+/-5% of nominal supply voltage** for frequencies between Fpmic to Fpcb (typ 20 – 100MHz)
- Max PCB Impedance (Z) vs Frequency (F) budget between Device's power inputs and PMIC's output power filter node including ground return is determined by applying the Frequency Domain Target Impedance Method to determine the PCB's maximum frequency of interest (Fpcb). Ideally a properly designed and decoupled PDN will exhibit smoothly increasing Z vs. F curve. There are 2 general regions of interest as can be seen in [Figure 7-14](#).
  - 1<sup>st</sup> area is from DC (0Hz) up to Fpmic (typ a few 100 kHz) where a PMIC's transient response characteristic (i.e. Switching Freq, Compensation Loop BW) dominate. A PDN's Z is typically very low due to power filtering & bulk capacitor values when PDN has very low trace resistance (i.e. good Reff performance). The goal is to maintain a smoothly increasing Z that is less than Zt1 over this low frequency range. This will ensure that a max transient current event will not cause a voltage drop more than the PMIC's current step response can support (typ 3%).
  - 2<sup>nd</sup> area is from Fpmic up to Fpcb (typ 20-100MHz) where a PCB's inherent characteristics (i.e. parasitic capacitance, planar spreading inductances) dominate. A PDN's Z will naturally increase with frequency. At frequencies between Fpmic up to Fpcb, the goal is to maintain a smoothly increasing Z to be less than Zt2. This will ensure that the high frequency content of a max transient current event will not cause a voltage drop to be more than 5% of the min supply voltage.



$$Z_T = \frac{\text{Max Voltage Rail Drop}^{\text{Note1}}}{\text{Max Transient Current}^{\text{Note2}}}$$

$$Z_{T1} = \frac{(\text{Min Voltage}) \times (\text{PMIC's Step Responce})}{(\sim 50\% \text{ of Max DC Current})} = \frac{V_{\text{min}} \times 3\%(\text{typ})}{I_{\text{max}} \times \sim 50\%}$$

$$Z_{T2} = \frac{(\text{Min Voltage}) \times (\text{High-Freq Transient Noise})}{(\sim 50\% \text{ of Max DC Current})} = \frac{V_{\text{min}} \times 5\%(\text{typ})}{I_{\text{max}} \times \sim 50\%}$$

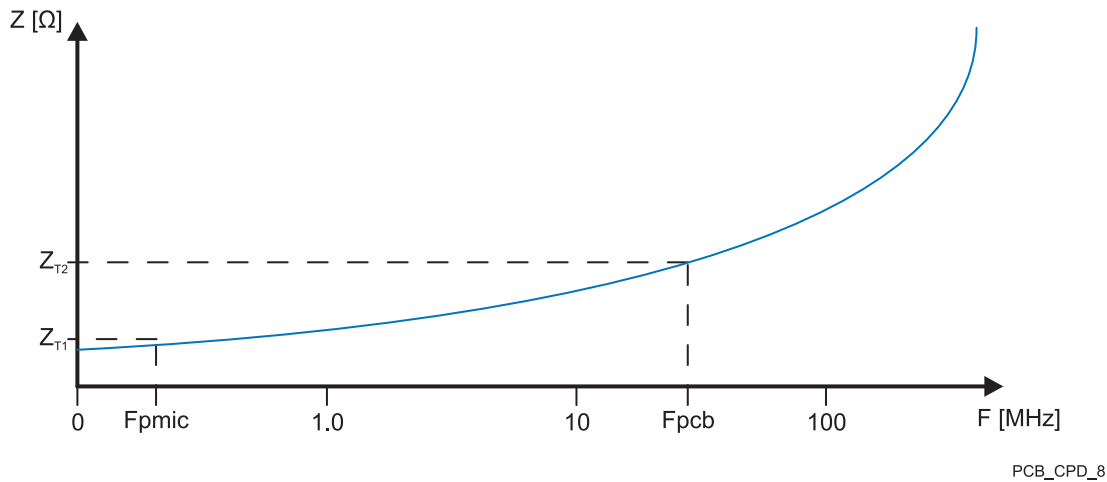

**Figure 7-14. PDN's Target impedance**

- 1.Voltage Rail Drop includes regulation accuracy, voltage distribution drops, and all dynamic events such as transient noise, AC ripple, voltage dips etc.
- 2.Typical max transient current is defined as 50% of max current draw possible.

### 7.3.2 Voltage Decoupling

Recommended power supply decoupling capacitors main characteristics for commercial products whose ambient temperature is not to exceed +85C are shown in table below:

**Table 7-1. Commercial Applications Recommended Decoupling Capacitors Characteristics<sup>(1)(2)(3)</sup>**

Value	Voltage [V]	Package	Stability	Dielectric	Capacitance Tolerance	Temp Range [°C]	Temp Sensitivity [%]	REFERENCE
22µF	6,3	0603	Class 2	X5R	- / + 20%	-55 to + 85	- / + 15	GRM188R60J226MEA0L
10µF	4,0	0402	Class 2	X5R	- / + 20%	-55 to + 85	- / + 15	GRM155R60G106ME44
4.7µF	6,3	0402	Class 2	X5R	- / + 20%	-55 to + 85	- / + 15	GRM155R60J475ME95
2.2µF	6,3	0402	Class 2	X5R	- / + 20%	-55 to + 85	- / + 15	GRM155R60J225ME95
1µF	6,3	0201	Class 2	X5R	- / + 20%	-55 to + 85	- / + 15	GRM033R60J105MEA2

**Table 7-1. Commercial Applications Recommended Decoupling Capacitors Characteristics<sup>(1)(2)(3)</sup> (continued)**

Value	Voltage [V]	Package	Stability	Dielectric	Capacitance Tolerance	Temp Range [°C]	Temp Sensitivity [%]	REFERENCE
470nF	6,3	0201	Class 2	X5R	- / + 20%	-55 to + 85	- / + 15	GRM033R60G474ME90
220nF	6,3	0201	Class 2	X5R	- / + 20%	-55 to + 85	- / + 15	GRM033R60J224ME90
100nF	6,3	0201	Class 2	X5R	- / + 20%	-55 to + 85	- / + 15	GRM033R60J104ME19

- (1) Minimum value for each PCB capacitor: 100 nF.
- (2) Among the different capacitors, 470 nF is recommended (not required) to filter at 5-MHz to 10-MHz frequency range.
- (3) In comparison with the EIA Class 1 dielectrics, Class 2 dielectric capacitors tend to have severe temperature drift, high dependence of capacitance on applied voltage, high voltage coefficient of dissipation factor, high frequency coefficient of dissipation, and problems with aging due to gradual change of crystal structure. Aging causes gradual exponential loss of capacitance and decrease of dissipation factor.

Recommended power supply decoupling capacitors main characteristics for automotive products are shown in table below:

**Table 7-2. Automotive Applications Recommended Decoupling Capacitors Characteristics<sup>(1)(2)</sup>**

Value	Voltage [V]	Package	AEC-Q200	Dielectric	Capacitance Tolerance	Temp Range [°C]	Temp Sensitivity [%]	REFERENCE
22μF	10	1206	Yes	X7R	- / + 10%	-55 to + 125	- / + 15	GCM31CR71A226KE02
10μF	10	0805	Yes	X7R	- / + 10%	-55 to + 125	- / + 15	GCM21BR71A106KE22
4.7μF	10	0805	Yes	X7S	- / + 10%	-55 to + 125	- / + 22	GCM21BC71A475KA73
2.2μF	6,3	0603	Yes	X7R	- / + 10%	-55 to + 125	- / + 15	GCM188R70J225KE22
1μF	10	0402	Yes	X7S	- / + 10%	-55 to + 125	- / + 22	GCM155C71A105KE38
470nF	10	0402	Yes	X7S	- / + 10%	-55 to + 125	- / + 22	GCM155C71A474KE36
220nF	25	0603	Yes	X7R	- / + 10%	-55 to + 125	- / + 15	GCM155R71A104KA55
100nF	10	0402	Yes	X7R	- / + 10%	-55 to + 125	- / + 15	GCM155R71C104MA55
100nF	6.3	0201	Yes	X7S	- / + 10%	-55 to + 125	- / + 15	GCM033C70J104K
1.0μF	10	3T-0805 <sup>(3)</sup>	Yes		- / + 20%	-55 to + 125		NFM21HC105R1C3
0.47μF	10	3T-0805 <sup>(3)</sup>	Yes		- / + 20%	-55 to + 125		NFM21HC474R1C3
0.22μF	10	3T-0805 <sup>(3)</sup>	Yes		- / + 20%	-55 to + 125		NFM21HC224R1C3
0.1μF	10	3T-0805 <sup>(3)</sup>	Yes		- / + 20%	-55 to + 125		NFM21HC104R1C3

- (1) Minimum value for each PCB capacitor: 100 nF.
- (2) Among the different capacitors, 470 nF is recommended (not required) to filter at 5-MHz to 10-MHz frequency range.
- (3) 3T designates this as a "3-terminal, low inductance type package".

### 7.3.3 Static PDN Analysis

One power net parameter derived from a PCB's PDN static analysis is the Effective Resistance (R<sub>eff</sub>). This is the total PCB power net routing resistance that is the sum of all the individual power net segments used to deliver a supply voltage to the point of load and includes any series resistive elements (i.e. current sensing resistor) that may be installed between the PMIC outputs and Processor inputs.

### 7.3.4 Dynamic PDN Analysis

Three power net parameters derived from a PCB's PDN dynamic analysis are the Loop Inductance (LL), Impedance (Z) and PCB Frequency of Interest (F<sub>pcb</sub>).

- LL values shown are the recommended max PCB trace inductance between a decoupling capacitor's power supply and ground reference terminals when viewed from the decoupling capacitor with a "theoretical shorted" applied across the Processor's supply inputs to ground reference.

- Z values shown are the recommended max PCB trace impedances allowed between Fpmic up to Fpcb frequency range that limits transient noise drops to no more than 5% of min supply voltage during max transient current events.
- Fpcb (Frequency of Interest) is defined to be a power rail's max frequency after which adding a reasonable number of decoupling capacitors no longer significantly reduces the power rail impedance below the desired impedance target (Zt2). This is due to the dominance of the PCB's parasitic planar spreading and internal package inductances.

**Table 7-3. Recommended PDN and Decoupling Characteristics** <sup>(1)(2)(3)(4)</sup>

PDN Analysis:  Supply	Static	Dynamic			Number of Recommended Decoupling Capacitors per Supply							
	Max R <sub>eff</sub> <sup>(5)</sup> [mΩ]	Dec. Cap. Max LL <sup>(6)</sup> [nH]	Max Impedance [mΩ]	Frequency range of Interest [MHz]	100 nF	220 nF	470 nF	1μF	2.2 μF	4.7 μF	10 μF	22 μF
vdd_dsp	22	2.5	54	≤20	6	1	1	1	1	1		1
vdd	18	2	57	≤20	6	1	1	1	1		1	
vdds_dds1	33	2.5	200	≤100	8	3		2		2		1
cap_vbbldo_dsp	N/A	6	N/A	N/A				1				
cap_vbbldo_gpu	N/A	6	N/A	N/A				1				
cap_vbbldo_iva	N/A	6	N/A	N/A				1				
cap_vbbldo_mpu	N/A	6	N/A	N/A				1				
cap_vddram_core1	N/A	6	N/A	N/A				1				
cap_vddram_core3	N/A	6	N/A	N/A				1				
cap_vddram_core4	N/A	6	N/A	N/A				1				
cap_vddram_dsp	N/A	6	N/A	N/A				1				
cap_vddram_gpu	N/A	6	N/A	N/A				1				
cap_vddram_iva	N/A	6	N/A	N/A				1				
cap_vddram_mpu	N/A	6	N/A	N/A				1				

(1) For more information on peak-to-peak noise values, see the Recommended Operating Conditions table of the Specifications chapter.

(2) ESL must be as low as possible and must not exceed 0.5 nH.

(3) The PDN (Power Delivery Network) impedance characteristics are defined versus the device activity (that runs at different frequency) based on the Recommended Operating Conditions table of the Specifications chapter.

(4) Maximum static voltage drop allowed drives the maximum acceptable power net resistance ( R<sub>eff</sub>) between the PMIC or the external SMPS and the processor power balls.

(5) Maximum R<sub>eff</sub> (from SMPS to Processor) allows for max supply voltage drop when both remote voltage sensing very close to processor power balls and TI recommended PMICs are used.

(6) Maximum Loop Inductance to each high-frequency (30-70MHz) decoupling capacitor.

### 7.3.5 Power Supply Mapping

TPS65919 or LP8733 are the Power Management ICs (PMICs) that should be used for the Device designs. TI requires use of these PMICs for the following reasons:

- TI has validated their use with the Device
- Board level margins including transient response and output accuracy are analyzed and optimized for the entire system
- Support for power sequencing requirements (refer to [Section 5.10.3 Power Supply Sequences](#))
- Support for Adaptive Voltage Scaling (AVS) Class 0 requirements, including TI provided software
- Remote sensing at point of load with output voltage compensation allows for the maximum IR drop budget

Whenever one SMPS supplies multiple SoC voltage domains from a common power rail, the most stringent PDN guideline across the voltage domains being combined should be applied to the common power rail.

It is possible that some voltage domains on the device are unused in some systems. In such cases, to ensure device reliability, it is still required that the supply pins for the specific voltage domains are connected to some core power supply output.

These unused supplies though can be combined with any of the core supplies that are used (active) in the system. e.g. if the DSP domain is not used, it can be combined with the CORE domain, thereby having a single power supply driving the combined CORE and DSP domains.

For the combined rail, the following relaxations do apply:

- The AVS voltage of active voltage domain in the combined rail needs to be used to set the power supply
- The decoupling capacitance should be set according to the active voltage domain in the combined rail
- The PDN guideline should be set according to the active voltage domain in the combined rail

[Table 7-4](#) illustrates the approved and validated power supply connections to the Device for the SMPS outputs of the TPS656919 PMIC.

**Table 7-4. TPS65919 Power Supply Connections<sup>(1)</sup>**

SMPS	Valid Combination	TPS65919 Current Limitation <sup>(2) (3)</sup>
SMPS1	VD_CORE	3.5A
SMPS2	Free (DDR Memory)	3.5A
SMPS3	VD_DSP	3A
SMPS4	VDDS18V	1.5A

(1) Power consumption is highly application-specific. Separate analysis must be performed to ensure output current ratings (average and peak) is within the limits of the PMIC for all rails of the device.

(2) Refer to the PMIC data manual for the latest TPS65919 specifications.

(3) A product's maximum ambient temperature, thermal system design & heat spreading performance could limit the maximum power dissipation below the full PMIC capacity in order to not exceed recommended SoC max Tj.

[Table 7-5](#) illustrates the approved and validated power supply connections to the Device for the SMPS outputs of the LP8733 PMIC.

**Table 7-5. LP8733 Power Supply Connections**

SMPS	Valid Combination	LP8733 Current Limitation <sup>(1)</sup> (2)
SMPS1	VD_CORE	3A
SMPS2	VD_DSP	3A

(1) Refer to the LP8733 Data Manual for exact current rating limitations, including assumed VIN and other parameters. Values provided in this table are for comparison purposes.

(2) Highly application-specific. Separate analysis must be performed to ensure average and peak power is within the limits of the PMIC.

### 7.3.6 DPLL Voltage Requirement

The voltage input to the DPLLs has a low noise requirement. Board designs should supply these voltage inputs with a low noise LDO to ensure they are isolated from any potential digital switching noise. The TPS65919 PMIC LDOLN output is specifically designed to meet this low noise requirement.

---

**NOTE**

For more information about Input Voltage Sources, see [Section 5.10.4.3 DPLLs, DLLs Specifications](#).

---

[Table 7-6](#) presents the voltage inputs that supply the DPLLs.

**Table 7-6. Input Voltage Power Supplies for the DPLLs**

POWER SUPPLY	DPLLs
vdda_per	DPLL_PER and PER HSDIVIDER analog power supply
vdda_ddr	DPLL_DDR and DDR HSDIVIDER analog power supply
vdda_debug	DPLL_DEBUG analog power supply
vdda_core_gmac	DPLL_CORE and HSDIVIDER analog power supply
vdda_gpu	DPLL_GPU analog power supply
vdda_video	DPLL_VIDEO1 analog power supply
vdda_mpu_abe	DPLL_MPU and DPLL_ABE analog power supply
vdda_osc	not DPLL input but is required to be supplied by low noise input voltage
vdda_dsp_iva	DSP PLL and IVA PLL analog power supply

### 7.3.7 Loss of Input Power Event

A few key PDN design items needed to enable a controlled and compliant SoC power down sequence for a “Loss of Input Power” event are:

- “Loss of Input Power” early warning
  - TI EVM and Reference Design Study SCHs and PDNs achieve this by using the First Stage Converter’s (i.e. LM536033-Q1) Power Good status output to enable and disable the Second Stage PMIC devices (i.e. TPS65917/919, LP8733, and LP8732). If a different First Stage Converter is used, care must be taken to ensure an adequate “PG\_Status” or “Vbatt\_Status” signal is provided that can disable Second Stage PMIC to begin a controlled and compliant SoC power down sequence. The total elapsed time from asserting “PG\_Status” low until SoC’s PMIC input voltage reaches minimum level of 2.75 V should be minimum of 1.5ms and 2ms preferred.
- Maximize discharge time of First Stage Vout (VSYS\_3V3 power rail = input voltage to SoC PMIC).
  - TI EVM and Reference Design Study SCHs and PDNs achieve this by opening an in-line load switch immediately upon “PG\_Status” low assertion in order to remove the SoC’s 3.3V IO load current from VSYS\_3V3. This will extend the VSYS\_3V3 power rail’s discharge time in order to maximize elapsed time for allowing SoC PMIC to execute a controlled and compliant power down sequence. Care should be taken to either disable or isolate any additional peripheral components that may be loading the VSYS\_3V3 rail as well.
- Sufficient bulk decoupling capacitance on the First Stage Vout (VSYS\_3V3 per PDN) that allows for desired 1.5 – 2 ms elapsed time as described above.
  - TI EVM and Reference Design Study SCHs and PDNs achieve this by using 200  $\mu$ F of total capacitance on VSYS\_3V3. The First Stage Converter (i.e. LM536033-Q1) can typically drive a max of 400  $\mu$ F to help extend VSYS\_3V3 discharge time for a compliant SoC power down sequence.
- Optimizing the Second Stage SoC PMIC’s OTP settings that determines SoC power up and down sequences and total elapsed time needed for a controlled sequence.
  - TI EVM and Reference Design Study SCHs and PDNs achieve this by using optimized OTPs per the SCH and components used. The definition of these OTPs is captured in the detailed timing diagrams for both power up and down sequences. The PDN diagram typically shows a recommended PMIC OTP ID based upon the SoC and DDR memory types.

### 7.3.8 Example PCB Design

The following sections describe an example PCB design and its resulting PDN performance for the vdd processor power domain.

#### NOTE

Materials presented in this section are based on generic PDN analysis on PCB boards and are not specific to systems integrating the Device.

#### 7.3.8.1 Example Stack-up

Layer Assignments:

- Layer Top: Signal and Segmented Power Plane
  - Processor and PMIC components placed on Top-side
- Layer 2: Gnd Plane1
- Layer 3: Signals
- Layer n: Power Plane1
- Layer n+1: Power Plane 2
- Layer n+2: Signal
- Layer n+3: Gnd Plane2
- Layer Bottom: Signal and Segmented Power Planes
  - Decoupling caps, etc.

Via Technology: Through-hole

Copper Weight:

- ½ oz for all signal layers.
- 1-2oz for all power plane for improved PCB heat spreading.

#### 7.3.8.2 vdd Example Analysis

Maximum acceptable PCB resistance ( $R_{\text{eff}}$ ) between the PMIC and Processor input power balls should not exceed 10m $\Omega$ .

Maximum decoupling capacitance loop inductance (LL) between Processor input power balls and decoupling capacitances should not exceed 2.0nH (ESL NOT included)

Impedance target for key frequency of interest between Processor input power balls and PMIC's SMPS output power balls should not exceed 57m $\Omega$  at 20MHz.

**Table 7-7. Example PCB vdd PI Analysis Summary**

Parameter	Recommendation	Example PCB
OPP	OPP_NOM	
Clocking Rate	266 MHz	
Voltage Level	1 V	1 V
Max Current Draw	1 A	1 A
Max Effective Resistance: Power Inductor Segment Total $R_{\text{eff}}$	10m $\Omega$	9.7 m $\Omega$
Max Loop Inductance	2.0nH	0.97 –1.75nH
Impedance Target	57m $\Omega$ F<20Mhz	57m $\Omega$ F<20Mhz

Figure 7-15 show a PCB layout example and the resulting PI analysis results.

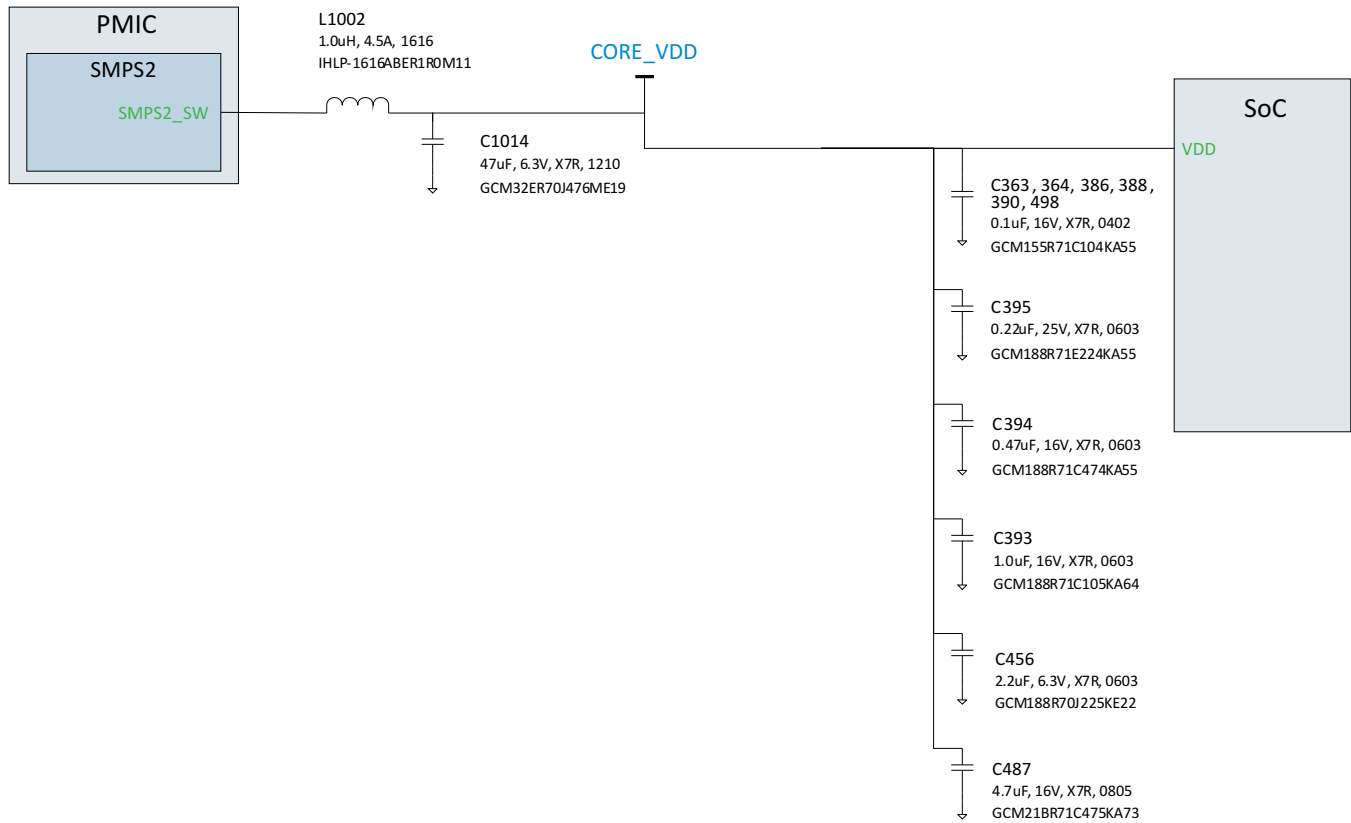

Figure 7-15. vdd Simplified SCH Diagram

**NOTE**

PCB Etch Resistance Breakdown, PDN Effective Resistance, and vdd routings are UNDER DEVELOPMENT!

IR Drop: vdd (PCB Rev Oct25, CAD sPSI v13.1.1)

- Source Conditions: 1V @ 1A
- Power Plane/Trace Effective Resistances
  - From PMIC SMPS to SoC load = 9.7mohm
  - From Power Inductor to SoC load = 6mohm
  - "Open-Loop" Voltage/IR Drop for 1A = 6mV

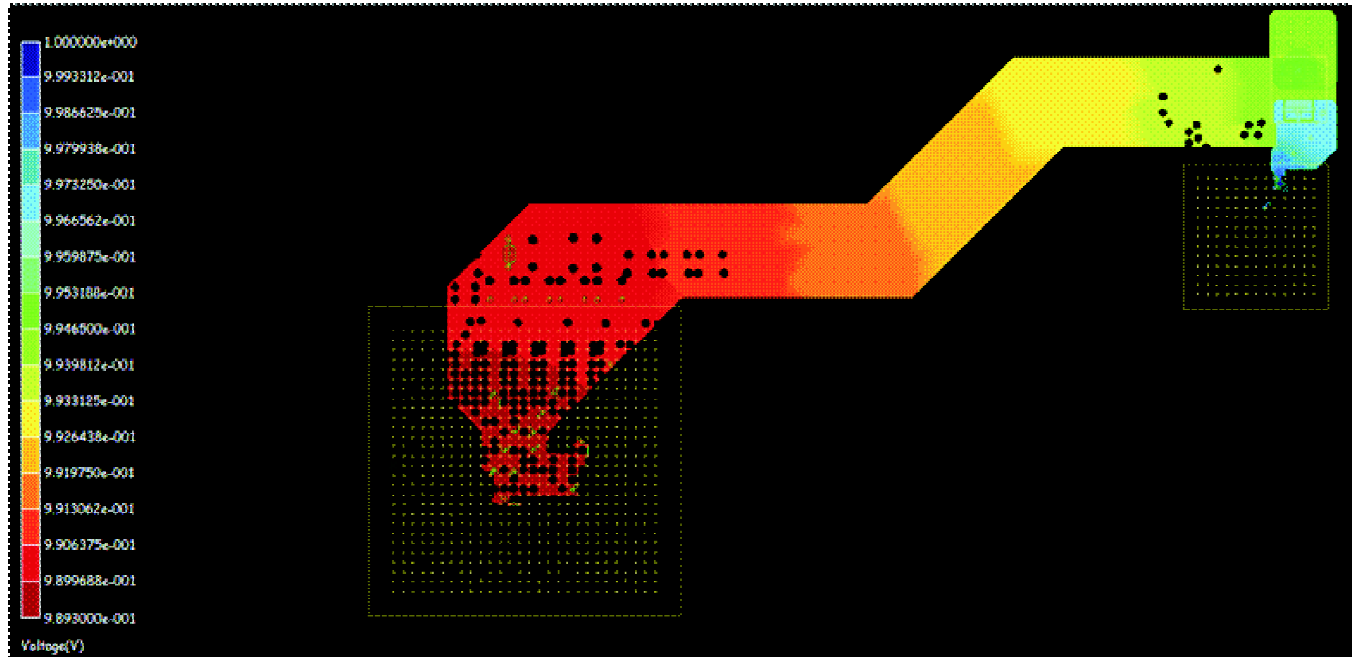

**Figure 7-16. vdd Voltage/IR Drop [All Layers]**

Dynamic analysis of this PCB design for the CORE power domain determined the vdd decoupling capacitor loop inductance and impedance vs frequency analysis shown below. As you can see, the loop inductance values ranged from 0.97 –1.75nH and were less than maximum 2.0nH recommended.

**NOTE**

Comparing loop inductances for capacitors at different distances from the SoC's input power balls shows an 18% reduction for caps placed closer. This was derived by averaging the inductances for the 3 caps with distances over 800mils (Avg LL = 1.33nH) vs the 3 caps with distances less than 600mils (Avg LL = 1.096nH).

**Table 7-8. Rail - vdd**

Cap Ref Des	Model Port #	Loop Inductance [nH]	Footprint Types	PCB Side	Distance to Ball-Field [mils]	Value [ $\mu$ F]	Size
C487	10	0.97	4vWSE	Top	521	4.7	0805
C393	6	1.11	4vWSE	Bottom	358	1.0	0603
C394	7	1.12	4vWSE	Bottom	357	0.47	0603
C456	9	1.13	4vWSE	Bottom	403	2.2	0603
C386	3	1.16	2vWSE	Bottom	40	0.1	0402
C395	8	1.18	4vWSE	Bottom	460	0.22	0603
C363	1	1.46	2vWSE	Bottom	40	0.1	0402
C390	5	1.48	2vWSE	Bottom	40	0.1	0402
C364	2	1.74	2vWSE	Bottom	40	0.1	0402
C498	11	1.74	2vWSE	Bottom	40	0.1	0402
C388	4	1.75	2vWSE	Bottom	40	0.1	0402



Loop Inductance range: 0.97 – 1.75nH

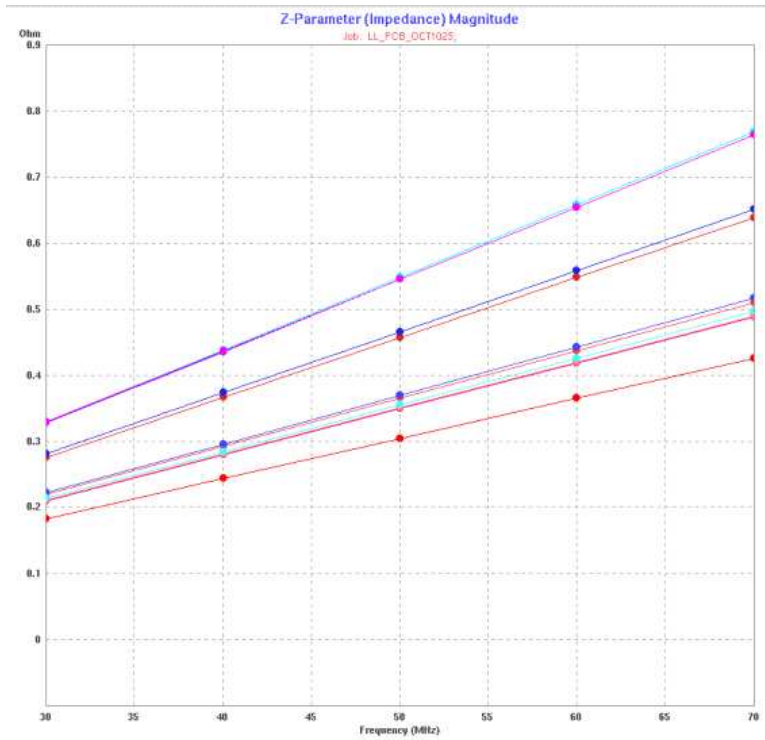

Figure 7-17. vdd Decoupling Cap Loop Inductances

Figure 7-18 shows vdd Impedance vs Frequency characteristics.

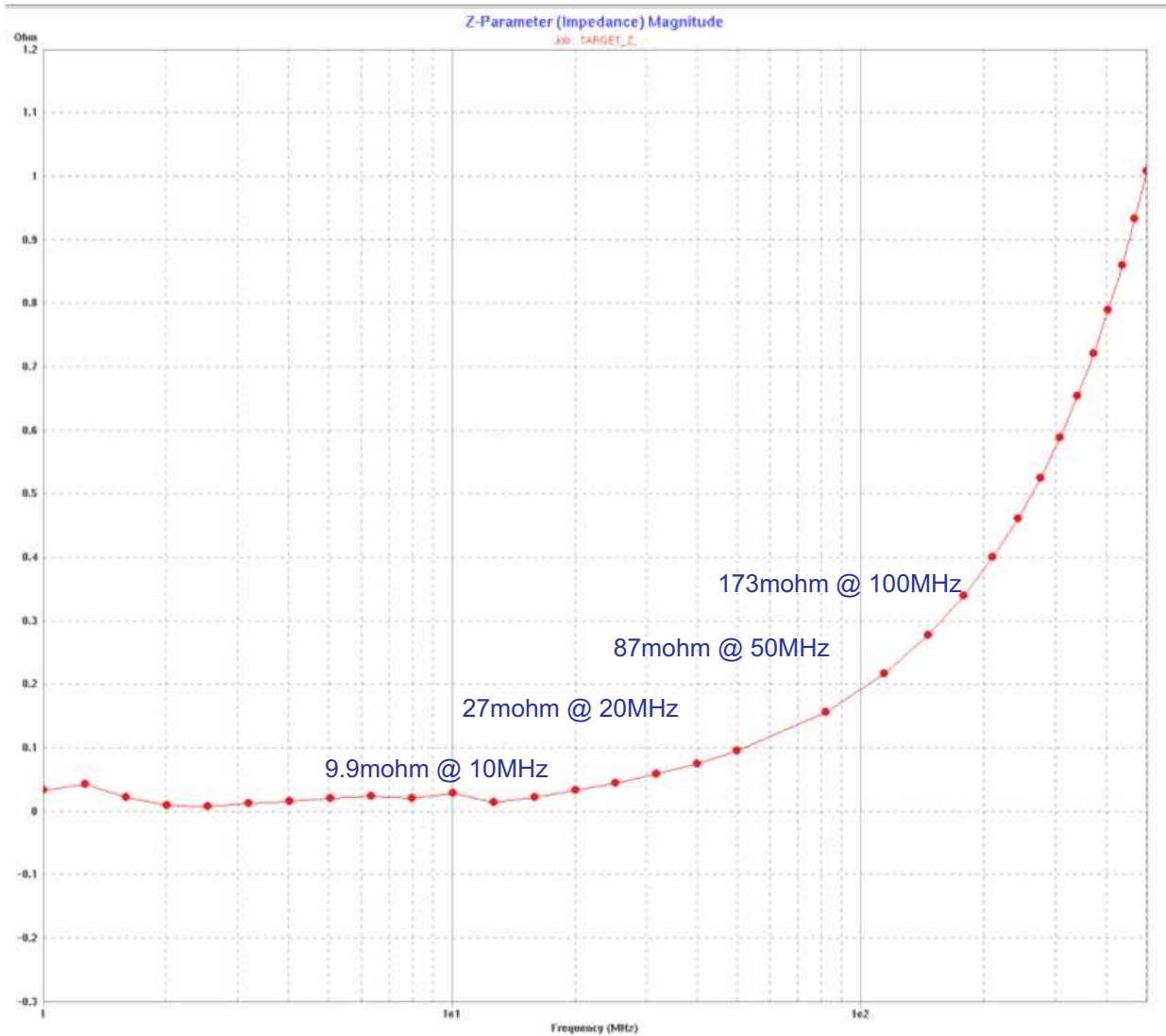

Figure 7-18. vdd Impedance vs Frequency

## 7.4 Single-Ended Interfaces

### 7.4.1 General Routing Guidelines

The following paragraphs detail the routing guidelines that must be observed when routing the various functional LVCMOS interfaces.

- Line spacing:
  - For a line width equal to  $W$ , the spacing between two lines must be  $2W$ , at least. This minimizes the crosstalk between switching signals between the different lines. On the PCB, this is not achievable everywhere (for example, when breaking signals out from the device package), but it is recommended to follow this rule as much as possible. When violating this guideline, minimize the length of the traces running parallel to each other (see [Figure 7-19](#)).

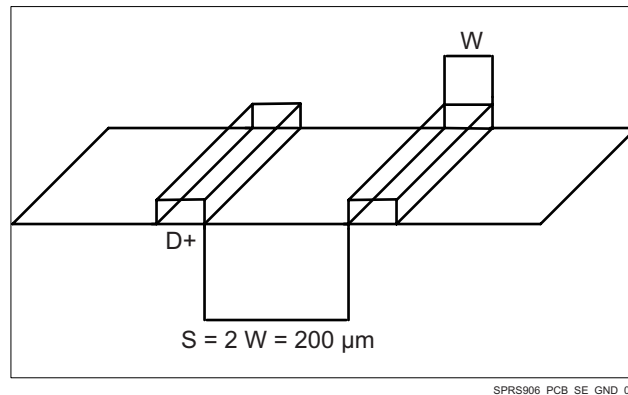

**Figure 7-19. Ground Guard Illustration**

- Length matching (unless otherwise specified):
  - For bus or traces at frequencies less than 10 MHz, the trace length matching (maximum length difference between the longest and the shortest lines) must be less than 25 mm.
  - For bus or traces at frequencies greater than 10 MHz, the trace length matching (maximum length difference between the longest and the shortest lines) must be less than 2.5 mm.
- Characteristic impedance
  - Unless otherwise specified, the characteristic impedance for single-ended interfaces is recommended to be between 35- $\Omega$  and 65- $\Omega$ .
- Multiple peripheral support
  - For interfaces where multiple peripherals have to be supported in the star topology, the length of each branch has to be balanced. Before closing the PCB design, it is highly recommended to verify signal integrity based on simulations including actual PCB extraction.

## 7.4.2 QSPI Board Design and Layout Guidelines

The following section details the routing guidelines that must be observed when routing the QSPI interfaces.

- The `qspi1_sclk` output signal must be looped back into the `qspi1_rtclk` input.
- The signal propagation delay from the `qspi1_sclk` ball to the QSPI device CLK input pin (A to C) must be approximately equal to the signal propagation delay from the QSPI device CLK pin to the `qspi1_rtclk` ball (C to D).
- The signal propagation delay from the QSPI device CLK pin to the `qspi1_rtclk` ball (C to D) must be approximately equal to the signal propagation delay of the control and data signals between the QSPI device and the SoC device (E to F, or F to E).
- The signal propagation delay from the `qspi1_sclk` signal to the series terminators ( $R2 = 10 \Omega$ ) near the QSPI device must be  $< 450\text{pS}$  ( $\sim 7\text{cm}$  as stripline or  $\sim 8\text{cm}$  as microstrip)
- 50  $\Omega$  PCB routing is recommended along with series terminations, as shown in [Figure 7-20](#).

- Propagation delays and matching:
  - A to C = C to D = E to F.
  - Matching skew: < 60pS
  - A to B < 450pS
  - B to C = as small as possible (<60pS)

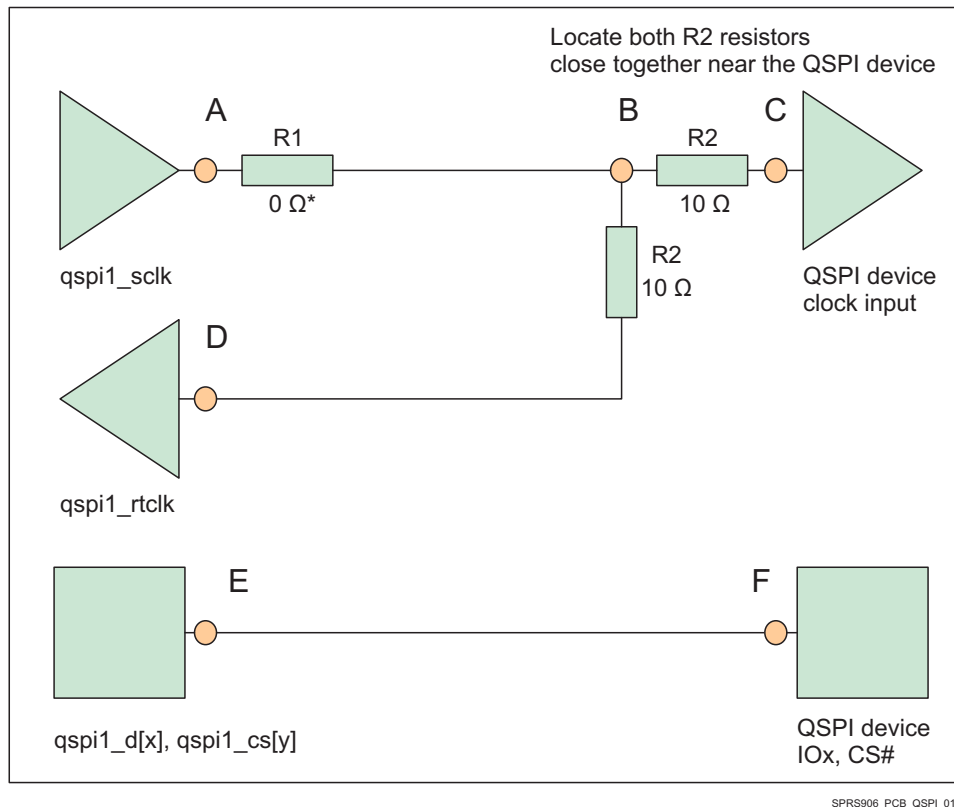

**Figure 7-20. QSPI Interface High Level Schematic**

**NOTE**

\*0 Ω resistor (R1), located as close as possible to the qspi1\_sclk pin, is placeholder for fine-tuning if needed.

## 7.5 Differential Interfaces

### 7.5.1 General Routing Guidelines

To maximize signal integrity, proper routing techniques for differential signals are important for high-speed designs. The following general routing guidelines describe the routing guidelines for differential lanes and differential signals.

- As much as possible, no other high-frequency signals must be routed in close proximity to the differential pair.
- Must be routed as differential traces on the same layer. The trace width and spacing must be chosen to yield the differential impedance value recommended.
- Minimize external components on differential lanes (like external ESD, probe points).
- Through-hole pins are not recommended.
- Differential lanes mustn't cross image planes (ground planes).
- No sharp bend on differential lanes.

- Number of vias on the differential pairs must be minimized, and identical on each line of the differential pair. In case of multiple differential lanes in the same interface, all lines should have the same number of vias.
- Shielded routing is to be promoted as much as possible (for instance, signals must be routed on internal layers that are inside power and/or ground planes).

## 7.5.2 USB 2.0 Board Design and Layout Guidelines

This section discusses schematic guidelines when designing a universal serial bus (USB) system.

### 7.5.2.1 Background

Clock frequencies generate the main source of energy in a USB design. The USB differential DP/DM pairs operate in high-speed mode at 480 Mbps. System clocks can operate at 12 MHz, 48 MHz, and 60 MHz. The USB cable can behave as a monopole antenna; take care to prevent RF currents from coupling onto the cable.

When designing a USB board, the signals of most interest are:

- Device interface signals: Clocks and other signal/data lines that run between devices on the PCB.
- Power going into and out of the cable: The USB connector socket pin 1 (VBUS ) may be heavily filtered and need only pass low frequency signals of less than ~100 KHz. The USB socket pin 4 (analog ground) must be able to return the current during data transmission, and must be filtered sparingly.
- Differential twisted pair signals going out on cable, DP and DM: Depending upon the data transfer rate, these device terminals can have signals with fundamental frequencies of 240 MHz (high speed), 6 MHz (full speed), and 750 kHz (low speed).
- External crystal circuit (device terminals XI and X0): 12 MHz, 19.2 MHz, 24 MHz, and 48 MHz fundamental. When using an external crystal as a reference clock, a 24 MHz and higher crystal is highly recommended.

### 7.5.2.2 USB PHY Layout Guide

The following sections describe in detail the specific guidelines for USB PHY Layout.

#### 7.5.2.2.1 General Routing and Placement

Use the following routing and placement guidelines when laying out a new design for the USB physical layer (PHY). These guidelines help minimize signal quality and electromagnetic interference (EMI) problems on a four-or-more layer evaluation module (EVM).

- Place the USB PHY and major components on the un-routed board first. For more details, see [Section 7.5.2.2.3](#).
- Route the high-speed clock and high-speed USB differential signals with minimum trace lengths.
- Route the high-speed USB signals on the plane closest to the ground plane, whenever possible.
- Route the high-speed USB signals using a minimum of vias and corners. This reduces signal reflections and impedance changes.
- When it becomes necessary to turn 90°, use two 45° turns or an arc instead of making a single 90° turn. This reduces reflections on the signal traces by minimizing impedance discontinuities.
- Do not route USB traces under or near crystals, oscillators, clock signal generators, switching regulators, mounting holes, magnetic devices or IC's that use or duplicate clock signals.
- Avoid stubs on the high-speed USB signals because they cause signal reflections. If a stub is unavoidable, then the stub should be less than 200 mils.
- Route all high-speed USB signal traces over continuous planes ( $V_{CC}$  or GND), with no interruptions. Avoid crossing over anti-etch, commonly found with plane splits.

### 7.5.2.2.2 Specific Guidelines for USB PHY Layout

The following sections describe in detail the specific guidelines for USB PHY Layout.

#### 7.5.2.2.2.1 Analog, PLL, and Digital Power Supply Filtering

To minimize EMI emissions, add decoupling capacitors with a ferrite bead at power supply terminals for the analog, phase-locked loop (PLL), and digital portions of the chip. Place this array as close to the chip as possible to minimize the inductance of the line and noise contributions to the system. An analog and digital supply example is shown in [Figure 7-21](#). In case of multiple power supply pins with the same function, tie them up to a single low-impedance point in the board and then add the decoupling capacitors, in addition to the ferrite bead. This array of caps and ferrite bead improve EMI and jitter performance. Take both EMI and jitter into account before altering the configuration.

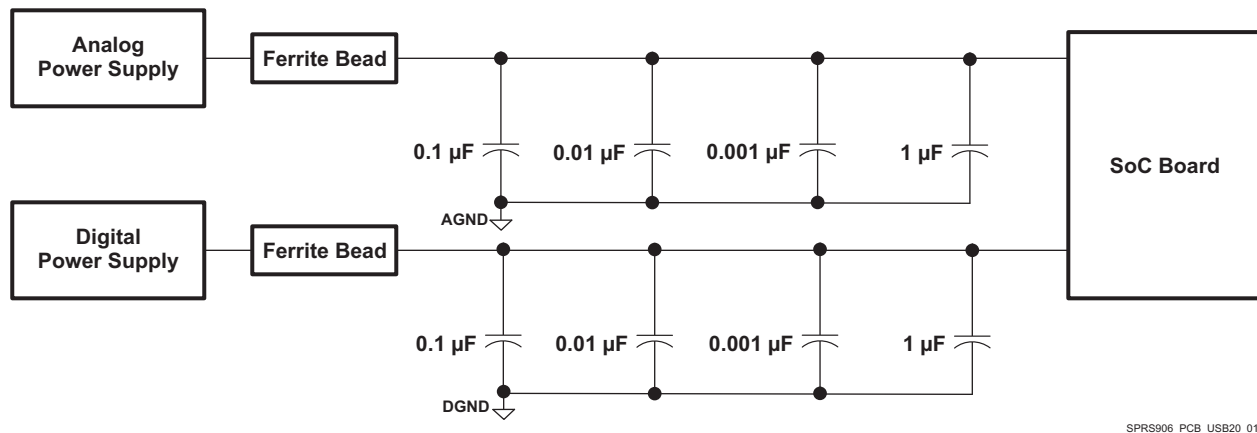

**Figure 7-21. Suggested Array Capacitors and a Ferrite Bead to Minimize EMI**

Consider the recommendations listed below to achieve proper ESD/EMI performance:

- Use a 0.01  $\mu\text{F}$  cap on each cable power VBUS line to chassis GND close to the USB connector pin.
- Use a 0.01  $\mu\text{F}$  cap on each cable ground line to chassis GND next to the USB connector pin.
- If voltage regulators are used, place a 0.01  $\mu\text{F}$  cap on both input and output. This is to increase the immunity to ESD and reduce EMI. For other requirements, see the device-specific datasheet.

#### 7.5.2.2.2.2 Analog, Digital, and PLL Partitioning

If separate power planes are used, they must be tied together at one point through a low-impedance bridge or preferably through a ferrite bead. Care must be taken to capacitively decouple each power rail close to the device. The analog ground, digital ground, and PLL ground must be tied together to the low-impedance circuit board ground plane.

#### 7.5.2.2.2.3 Board Stackup

Because of the high frequencies associated with the USB, a printed circuit board with at least four layers is recommended; two signal layers separated by a ground and power layer as shown in [Figure 7-22](#).

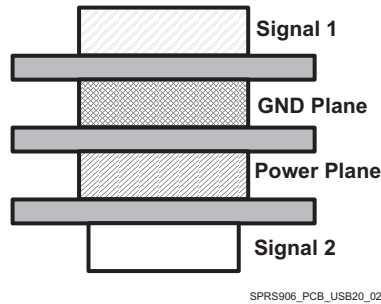

Figure 7-22. Four-Layer Board Stack-Up

The majority of signal traces should run on a single layer, preferably SIGNAL1. Immediately next to this layer should be the GND plane, which is solid with no cuts. Avoid running signal traces across a split in the ground or power plane. When running across split planes is unavoidable, sufficient decoupling must be used. Minimizing the number of signal vias reduces EMI by reducing inductance at high frequencies.

#### 7.5.2.2.4 Cable Connector Socket

Short the cable connector sockets directly to a small chassis ground plane (*GND strap*) that exists immediately underneath the connector sockets. This shorts EMI (and ESD) directly to the chassis ground before it gets onto the USB cable. This etch plane should be as large as possible, but all the conductors coming off connector pins 1 through 6 must have the board signal GND plane run under. If needed, scoop out the chassis GND strap etch to allow for the signal ground to extend under the connector pins. Note that the etches coming from pins 1 and 4 (VBUS power and GND) should be wide and via-ed to their respective planes as soon as possible, respecting the filtering that may be in place between the connector pin and the plane. See [Figure 7-23](#) for a schematic example.

Place a ferrite in series with the cable shield pins near the USB connector socket to keep EMI from getting onto the cable shield. The ferrite bead between the cable shield and ground may be valued between 10  $\Omega$  and 50  $\Omega$  at 100 MHz; it should be resistive to approximately 1 GHz. To keep EMI from getting onto the cable bus power wire (a very large antenna) a ferrite may be placed in series with cable bus power, VBUS, near the USB connector pin 1. The ferrite bead between connector pin 1 and bus power may be valued between 47  $\Omega$  and approximately 1000  $\Omega$  at 100 MHz. It should continue being resistive out to approximately 1 GHz, as shown in [Figure 7-23](#).

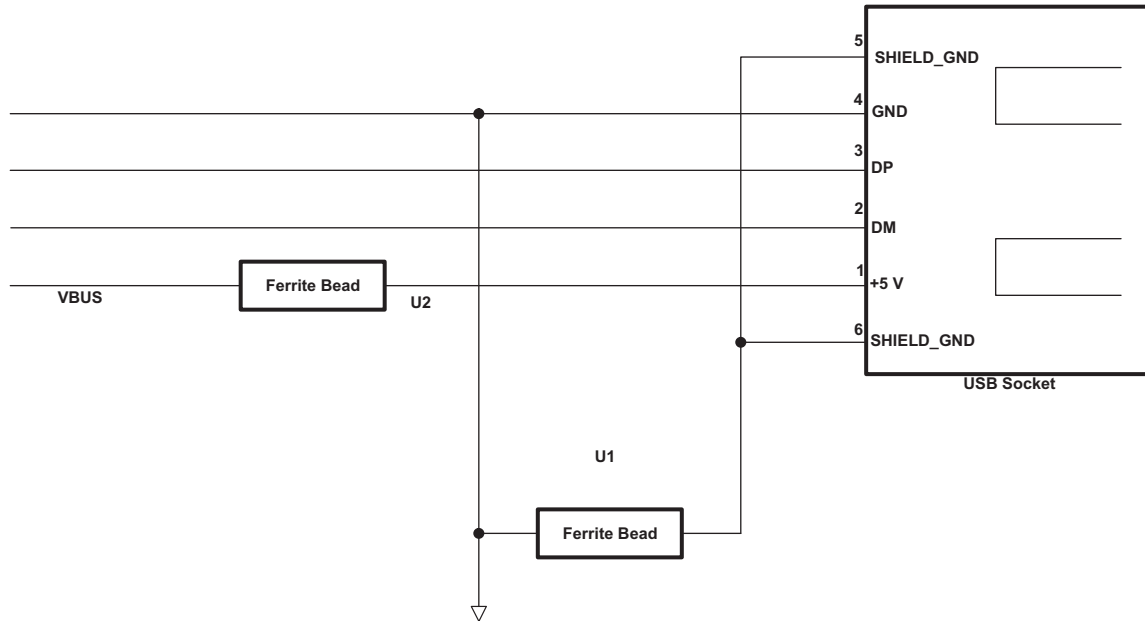

SPRS906\_PCB\_USB20\_03

Figure 7-23. USB Connector

#### 7.5.2.2.5 Clock Routings

To address the system clock emissions between devices, place a ~10 to 130  $\Omega$  resistor in series with the clock signal. Use a trial and error method of looking at the shape of the clock waveform on a high-speed oscilloscope and of tuning the value of the resistance to minimize waveform distortion. The value on this resistor should be as small as possible to get the desired effect. Place the resistor close to the device generating the clock signal. If an external crystal is used, follow the guidelines detailed in the *Selection and Specification of Crystals for Texas Instruments USB 2.0 Devices* (SLLA122).

When routing the clock traces from one device to another, try to use the 3W spacing rule. The distance from the center of the clock trace to the center of any adjacent signal trace should be at least three times the width of the clock trace. Many clocks, including slow frequency clocks, can have fast rise and fall times. Using the 3W rule cuts down on crosstalk between traces. In general, leave space between each of the traces running parallel between the devices. Avoid using right angles when routing traces to minimize the routing distance and impedance discontinuities. For further protection from crosstalk, run guard traces beside the clock signals (GND pin to GND pin), if possible. This lessens clock signal coupling, as shown in Figure 7-24.

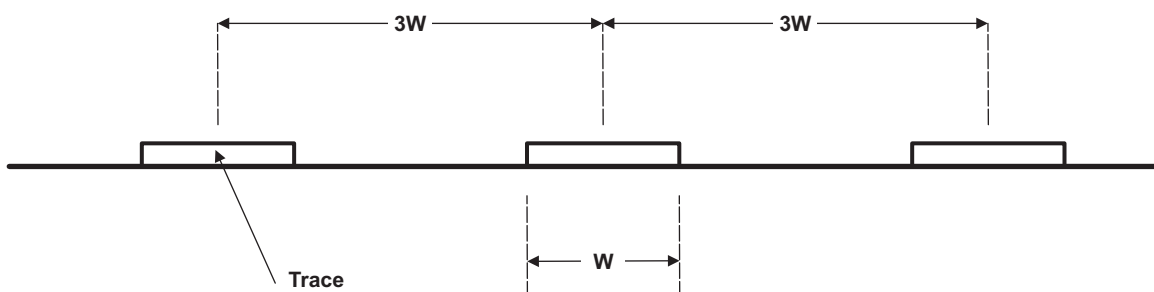

SPRS906\_PCB\_USB20\_04

Figure 7-24. 3W Spacing Rule



### 7.5.2.2.2.6 Crystals/Oscillator

Keep the crystal and its load capacitors close to the USB PHY pins, XI and XO (see [Figure 7-25](#)). Note that frequencies from power sources or large capacitors can cause modulations within the clock and should not be placed near the crystal. In these instances, errors such as dropped packets occur. A placeholder for a resistor, in parallel with the crystal, can be incorporated in the design to assist oscillator startup.

Power is proportional to the current squared. The current is  $I = C \times dv/dt$ , because  $dv/dt$  is a function of the PHY, current is proportional to the capacitive load. Cutting the load to 1/2 decreases the current by 1/2 and the power to 1/4 of the original value. For more details on crystal selection, see the *Selection and Specification of Crystals for Texas Instruments USB 2.0 Devices* ([SLLA122](#)).

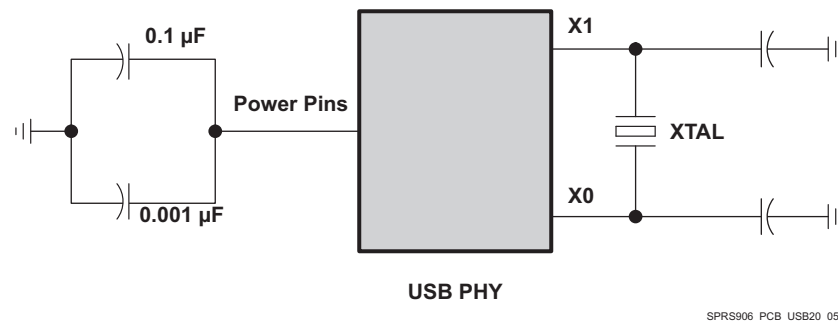
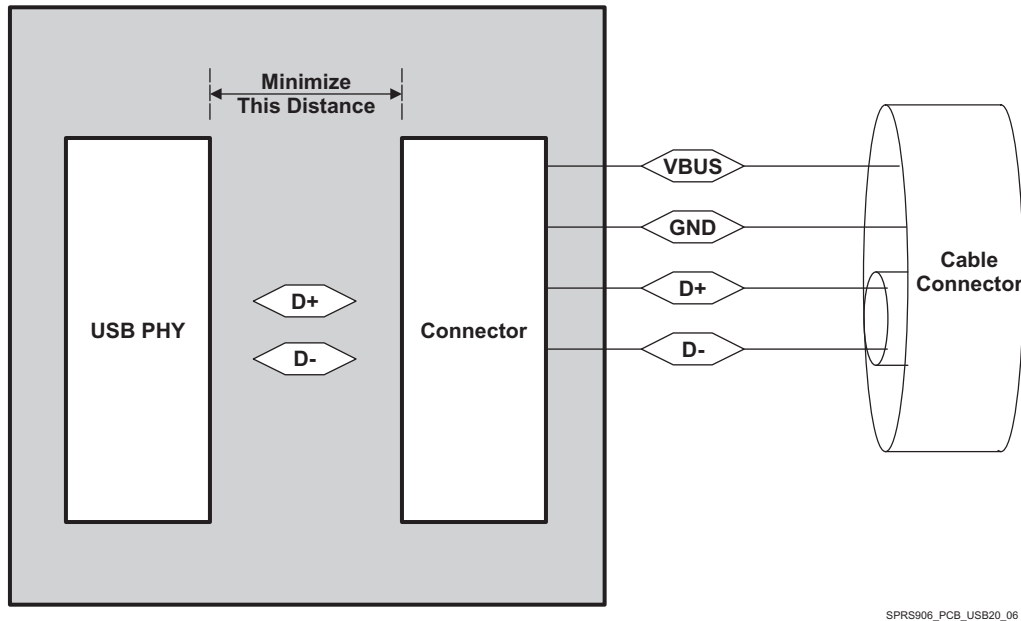

**Figure 7-25. Power Supply and Clock Connection to the USB PHY**

### 7.5.2.2.2.7 DP/DM Trace

Place the USB PHY as close as possible to the USB 2.0 connector. The signal swing during high-speed operation on the DP/DM lines is relatively small ( $400 \text{ mV} \pm 10\%$ ), so any differential noise picked up on the twisted pair can affect the received signal. When the DP/DM traces do not have any shielding, the traces tend to behave like an antenna and picks up noise generated by the surrounding components in the environment. To minimize the effect of this behavior:

- DP/DM traces should always be matched lengths and must be no more than 4 inches in length; otherwise, the eye opening may be degraded (see [Figure 7-26](#)).
- Route DP/DM traces close together for noise rejection on differential signals, parallel to each other and within two mils in length of each other. The measurement for trace length must be started from device's balls.
- A high-speed USB connection is made through a shielded, twisted pair cable with a differential characteristic impedance of  $90 \Omega \pm 15\%$ . In layout, the impedance of DP and DM should each be  $45 \Omega \pm 10\%$ .
- DP/DM traces should not have any extra components to maintain signal integrity. For example, traces cannot be routed to two USB connectors.



**Figure 7-26. USB PHY Connector and Cable Connector**

#### 7.5.2.2.8 DP/DM Vias

When a via must be used, increase the clearance size around it to minimize its capacitance. Each via introduces discontinuities in the signal's transmission line and increases the chance of picking up interference from the other layers of the board. Be careful when designing test points on twisted pair lines; through-hole pins are not recommended.

#### 7.5.2.2.9 Image Planes

An image plane is a layer of copper (voltage plane or ground plane), physically adjacent to a signal routing plane. Use of image planes provides a low impedance, shortest possible return path for RF currents. For a USB board, the best image plane is the ground plane because it can be used for both analog and digital circuits.

- Do not route traces so they cross from one plane to the other. This can cause a broken RF return path resulting in an EMI radiating loop as shown in [Figure 7-27](#). This is important for higher frequency or repetitive signals. Therefore, on a multi-layer board, it is best to run all clock signals on the signal plane above a solid ground plane.
- Avoid crossing the image power or ground plane boundaries with high-speed clock signal traces immediately above or below the separated planes. This also holds true for the twisted pair signals (DP, DM). Any unused area of the top and bottom signal layers of the PCB can be filled with copper that is connected to the ground plane through vias.

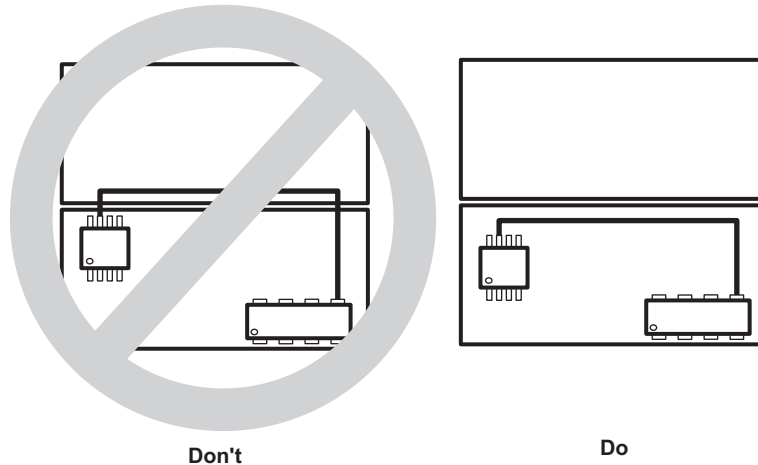

SPRS906\_PCB\_USB20\_07

**Figure 7-27. Do Not Cross Plane Boundaries**

- Do not overlap planes that do not reference each other. For example, do not overlap a digital power plane with an analog power plane as this produces a capacitance between the overlapping areas that could pass RF emissions from one plane to the other, as shown in [Figure 7-28](#).

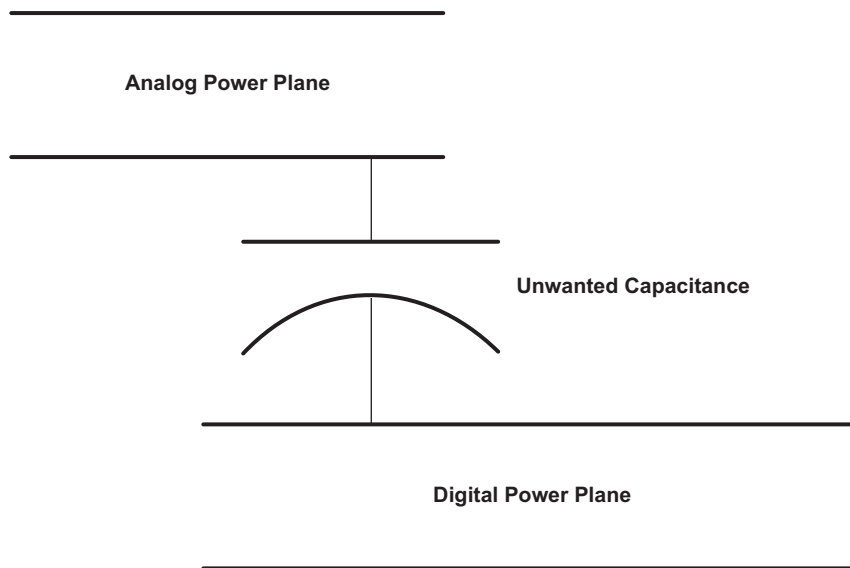

SPRS906\_PCB\_USB20\_08

**Figure 7-28. Do Not Overlap Planes**

- Avoid image plane violations. Traces that route over a slot in an image plane results in a possible RF return loop, as shown in [Figure 7-29](#).

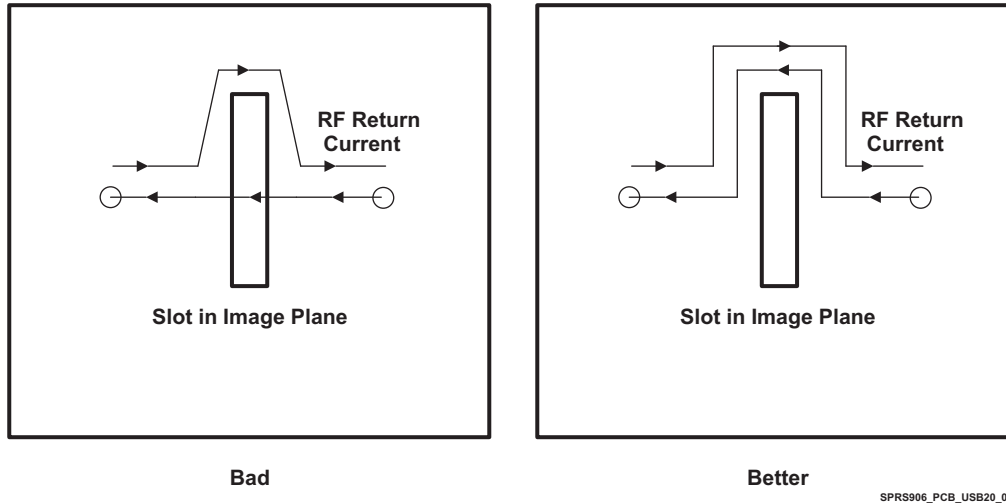

**Figure 7-29. Do Not Violate Image Planes**

SPRS906\_PCB\_USB20\_09

#### 7.5.2.2.2.10 Power Regulators

Switching power regulators are a source of noise and can cause noise coupling if placed close to sensitive areas on a circuit board. Therefore, the switching power regulator should be kept away from the DP/DM signals, the external clock crystal (or clock oscillator), and the USB PHY.

#### 7.5.2.3 References

- *USB 2.0 Specification*, Intel, 2000, <http://www.usb.org/developers/docs/>
- *High Speed USB Platform Design Guidelines*, Intel, 2000, [http://www.intel.com/technology/usb/download/usb2dg\\_R1\\_0.pdf](http://www.intel.com/technology/usb/download/usb2dg_R1_0.pdf)
- *Selection and Specification of Crystals for Texas Instruments USB 2.0 Devices (SLLA122)*

### 7.5.3 USB 3.0 Board Design and Layout Guidelines

This section provides the timing specification for the USB3.0 (USB1 in the device) interface as a PCB design and manufacturing specification. The design rules constrain PCB trace length, PCB trace skew, signal integrity, cross-talk, and signal timing. TI has performed the simulation and system design work to ensure the USB3.0 interface requirements are met. The design rules stated within this document are targeted at DEVICE mode electrical compliance. HOST mode and/or systems that do not include the 3m USB cable and far-end 11-inch PCB trace required by DEVICE mode compliance testing may not need the complete list of optimizations shown in this document; however, applying these optimizations to HOST mode systems will lead to optimal DEVICE mode performance.

#### 7.5.3.1 USB 3.0 interface introduction

The USB 3.0 has two unidirectional differential pairs: TXp/TXn pair and RXp/RXn pair. AC coupling caps are needed on the board for TX traces.

Figure 7-30 present high level schematic diagram for USB 3.0 interface.

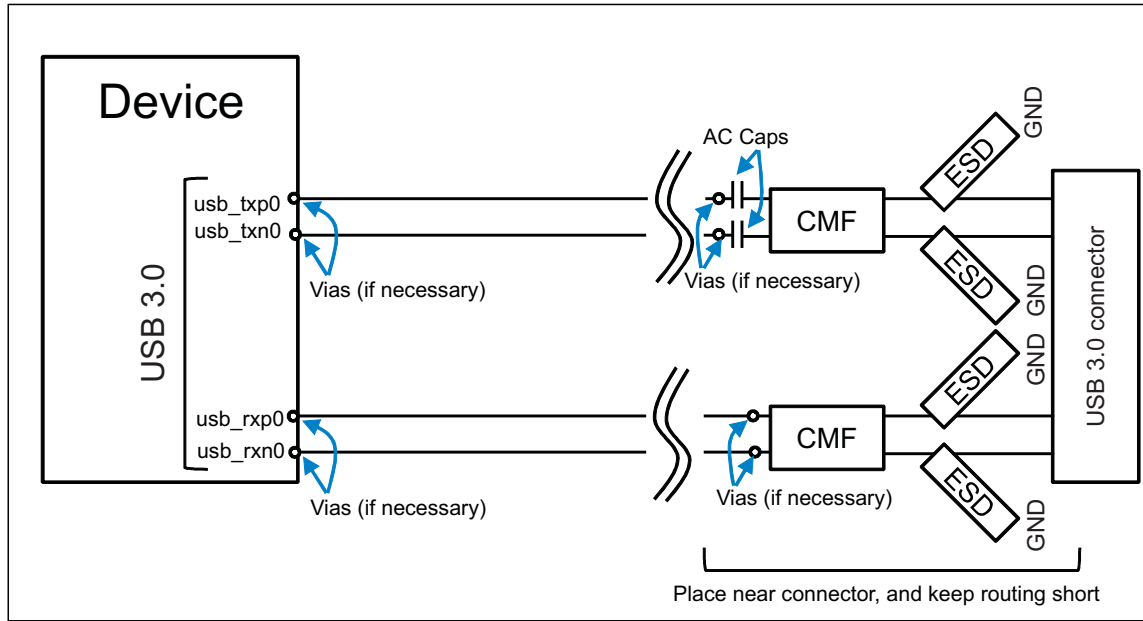

SPRS85x\_PCB\_USB30\_1

Figure 7-30. USB 3.0 Interface High Level Schematic

**NOTE**

ESD components should be on a PCB layer next to a system GND plane layer so the inductance of the via to GND will be minimal.

If vias are used, place the vias near the AC Caps or CMFs and under the SoC BGA, if necessary.

Figure 7-31 present placement diagram for USB 3.0 interface.

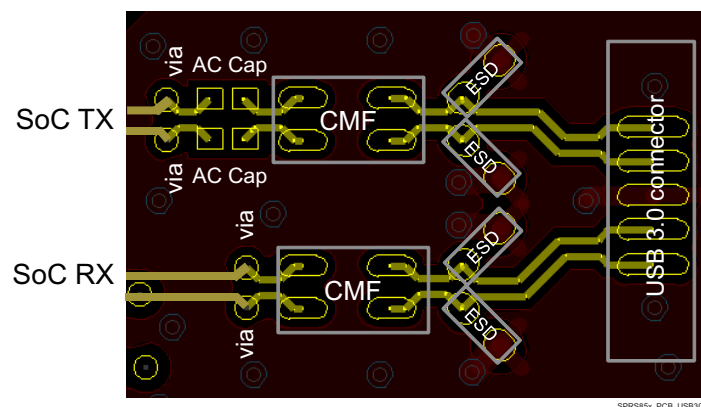

SPRS85x\_PCB\_USB30\_2

Figure 7-31. USB 3.0 placement diagram

Table 7-9. USB1 Component Reference

INTERFACE	COMPONENT	SUPPLIER	PART NUMBER
USB3 PHY	ESD	TI	TPD1E05U06
	CMF	Murata	DLW21SN900HQ2
	C	-	100nF (typical size: 0201)

### 7.5.3.2 USB 3.0 General routing rules

Some general routing guidelines regarding USB 3.0:

- Avoid crossing splits reference plane(s).
- Shorter trace length is preferred.
- Minimize the via usage and layer transition
- Keep large spacing between TX and RX pairs.
- Intra-lane delay mismatch between DP and DM less than 1ps. Same for RXp and RXn.
- Distance between common mode filter (CMF) and ESD protection device should be as short as possible
- Distance between ESD protection device and USB connector should be as short as possible.
- Distance between AC capacitors (TX only) and CMF should be as short as possible.
- USB 3.0 signals should always be routed over an adjacent ground plane.

Table 7-10 and Table 7-11 present routing specification and recommendations for USB1 in the device.

**Table 7-10. USB1 Routing Specifications**

PARAMETER	MIN	TYP	MAX	UNIT
Device balls to USB 3.0 connector trace length			3500	Mils
Skew within a differential pair		3	6	Mils
Number of stubs allowed on TX/RX traces			0	Stubs
TX/RX pair differential impedance	83	90	97	$\Omega$
Number of vias on each TX/RX trace			2	Vias
Differential pair to any other trace spacing	2xDS	3xDS		
Number of ground plane cuts allowed within USB3 routing region (except for specific ground carving as explained in this document)			0	Cuts
Number of layers between USB3.0 routing region and reference ground plane			0	Layers
PCB trace width		6		Mils
PCB BGA escape via pad size		18		Mils
PCB BGA escape via hole size		10		Mils

1. Vias must be used in pairs and spaced equally along a signal path.
2. DS = differential spacing of the traces.
3. Exceptions may be necessary in the SoC package BGA area.
4. GND guard-bands on the same layer may be closer, but should not be allowed to affect the impedance of the differential pair routing. GND guard-bands to isolate USB3.0 differential pairs from all other signals are recommended.

**Table 7-11. USB1 Routing Recommendations**

Item	Description	Reason
ESD location	Place ESD component on same layer as connector (no via or stub to ESD component)	Eliminate reflection loss from via & stub to ESD
ESD part number	TPD1E05U06	Minimize capacitance (0.42pF)
CMF part number	DLW21SN900HQ2	Manufacturer's recommended device
Connector	Use USB3.0 connector with supporting s-parameter model	Enable full signal chain simulation
Carve Ground	Carve GND underneath AC Caps, ESD, CMF, and connector	Minimize capacitance under ESD and CMF

**Table 7-11. USB1 Routing Recommendations (continued)**

Item	Description	Reason
Round pads	Minimize pad size and round the corners of the pads for the ESD and CMF components	Minimize capacitance
Vias	Max 2 vias per signal trace. If vias are required, place vias close to the AC Caps and CMFs. Vias under the SoC grid array may be used if necessary to route signals away from BGA pattern.	Vias significantly degrade signal integrity at 2.5GHz

Figure 7-32 presents an example layout, demonstrating the “carve GND” concept.

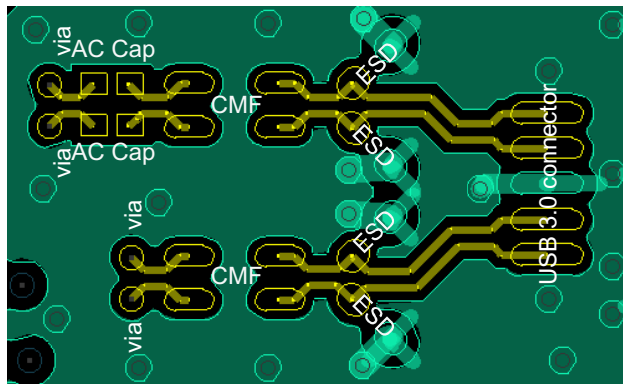

**Top Layer:** Routing from SoC through AC Caps, CMF, and ESD to connector.

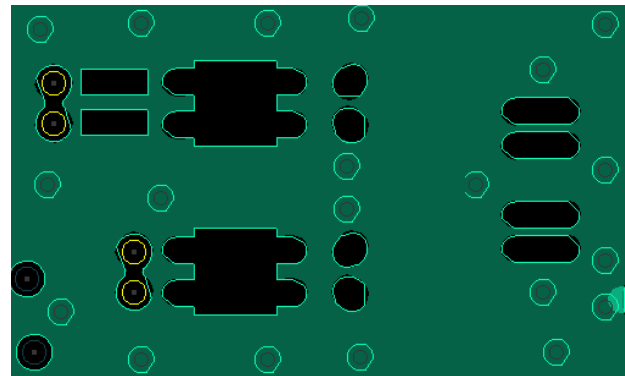

**Layer2, GND:** Gaps carved in GND underneath AC Caps, CMF, ESD, and connector.



**Layer3, Signal:** Implement as keep-out zone underneath carved GND areas.

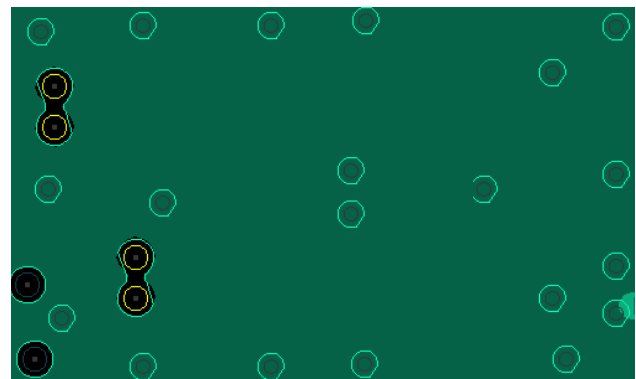

**Layer4, GND Plane** underneath AC Caps, CMF, ESD, and connector.

SPRS85x\_PCB\_USB30\_3

**Figure 7-32. USB 3.0 Example “carve GND” layout**

### 7.5.4 HDMI Board Design and Layout Guidelines

This section provides the timing specification for the HDMI interface as a PCB design and manufacturing specification. The design rules constrain PCB trace length, PCB trace skew, signal integrity, cross-talk, and signal timing. TI has performed the simulation and system design work to ensure the HDMI interface requirements are met. The design rules stated within this document are targeted at resolutions less than or equal to 1080p60 with 8-bit color; deep color (10-bit) requires further signal integrity optimization.

#### 7.5.4.1 HDMI Interface Schematic

The HDMI bus is separated into three main sections (HDMI Ethernet and the optional Audio Return Channel are not specifically supported by this Device):

1. Transition Minimized Differential Signaling (TMDS) high speed digital video interface
2. Display Data Channel (I2C bus for configuration and status exchange between two devices)
3. Consumer Electronics Control (optional) for remote control of connected devices.

The DDC and CEC are low speed interfaces, so nothing special is required for PCB layout of these signals.

The TMDS channels are high speed differential pairs and therefore require the most care in layout. Specifications for TMDS layout are below.

Figure 7-33 shows the HDMI interface schematic.

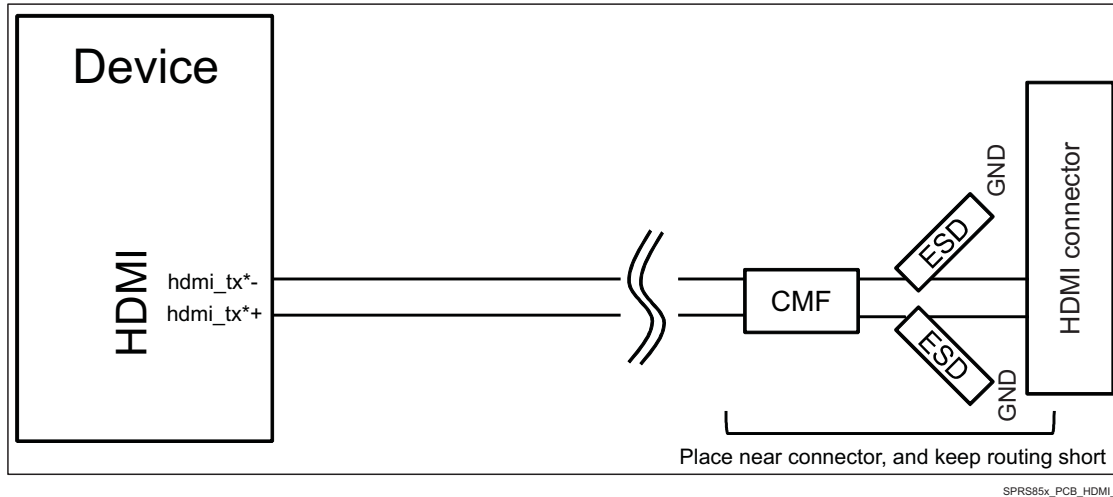

SPRS85x\_PCB\_HDMI\_1

Figure 7-33. HDMI Interface High Level Schematic

Figure 7-34 presents placement diagram for HDMI interface.

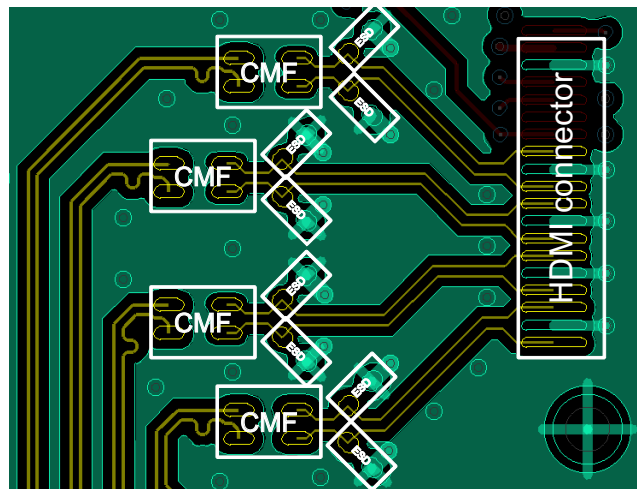

SPRS85x\_PCB\_HDMI\_2

Figure 7-34. HDMI Placement Diagram

Table 7-12. HDMI Component Reference

INTERFACE	DEVICE	SUPPLIER	PART NUMBER
HDMI	ESD	TI	TPD1E05U06
	CMF	Murata	DLW21SN900HQ2



### 7.5.4.2 TMDS General Routing Guidelines

The TMDS signals are high speed differential pairs. Care must be taken in the PCB layout of these signals to ensure good signal integrity.

The TMDS differential signal traces must be routed to achieve 100 Ohms (+/- 10%) differential impedance and 60 ohms (+/-10%) single ended impedance. Single ended impedance control is required because differential signals can't be closely coupled on PCBs and therefore single ended impedance becomes important.

These impedances are impacted by trace width, trace spacing, distance to reference planes, and dielectric material. Verify with a PCB design tool that the trace geometry for both data signal pairs results in as close to 60 ohms impedance traces as possible. For best accuracy, work with your PCB fabricator to ensure this impedance is met.

In general, closely coupled differential signal traces are not an advantage on PCBs. When differential signals are closely coupled, tight spacing and width control is necessary. Very small width and spacing variations affect impedance dramatically, so tight impedance control can be more problematic to maintain in production.

Loosely coupled PCB differential signals make impedance control much easier. Wider traces and spacing make obstacle avoidance easier, and trace width variations don't affect impedance as much, therefore it's easier to maintain accurate impedance over the length of the signal. The wider traces also show reduced skin effect and therefore often result in better signal integrity.

Some general routing guidelines regarding TMDS:

- Avoid crossing splits reference plane(s).
- Shorter trace length is preferred.
- Distance between common mode filter (CMF) and ESD protection device should be as short as possible
- Distance between ESD protection device and HDMI connector should be as short as possible.

Table 7-13 shows the routing specifications for the TMDS signals.

**Table 7-13. TMDS Routing Specifications**

PARAMETER	MIN	TYP	MAX	UNIT
Device balls to HDMI header trace length			4000	Mils
Skew within a differential pair		3	5	Mils
Number of stubs allowed on TMDS traces			0	stubs
TMDS pair differential impedance	90	100	110	$\Omega$
TMDS single-ended impedance	54	60	66	$\Omega$
Number of vias on each TMDS trace			0	Vias
TMDS differential pair to any other trace spacing <sup>(1) (2) (3)</sup>	2xDS	3xDS		Mils
Number of ground plane cuts allowed within HDMI routing region (except for specific ground carving as explained in this document)			0	Cuts
Number of layers between HDMI routing region and reference ground plane			0	Layers
PCB trace width		4.4		Mils

(1) DS = differential spacing of the traces.

(2) Exceptions may be necessary in the SoC package BGA area.

(3) GND guard-bands may be closer, but should not be allowed to affect the impedance of the differential pair routing. GND guard-bands to isolate HDMI differential pairs from all other signals is recommended.

**Table 7-14. TDMS Routing Recommendations**

Item	Description	Reason
ESD part number	TPD1E05U06	Minimize capacitance (0.42pF)

**Table 7-14. TDMS Routing Recommendations (continued)**

Item	Description	Reason
Carve Ground	Carve GND underneath ESD and CMF	Minimize capacitance under ESD and CMF
Round pads	Reduce pad size and round the corners of the pads for the ESD and CMF components	Minimize capacitance
Routing layer	Route all signals only on the same layer as SoC	Minimize reflection loss

Figure 7-35 presents an example layout, demonstrating the “carve GND” concept.

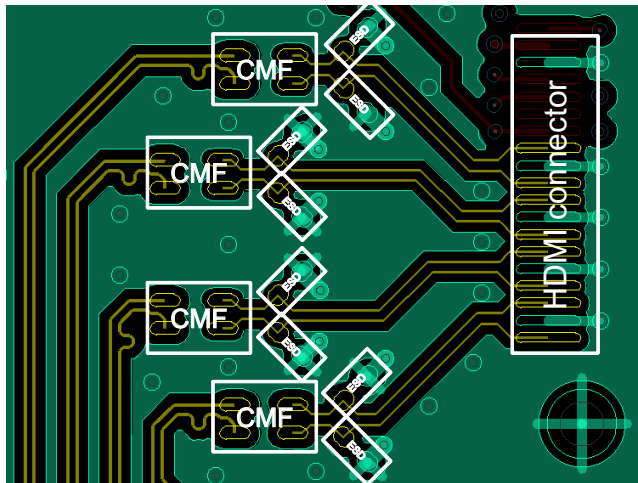

**Top Layer:** Routing from SoC through CMF, and ESD to connector.

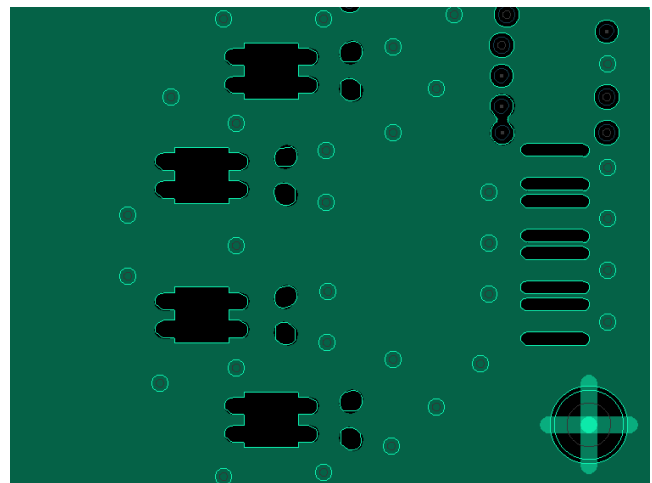

**Layer2, GND:** Gaps carved in GND underneath, CMF, ESD, and connector.

SPRS969x\_PCB\_HDMI\_3

**Figure 7-35. HDMI Example “carve GND” layout**

**7.5.4.3 TPD5S115**

The TPD5S115 is an integrated HDMI companion chip solution. The device provides a regulated 5 V output (5VOUT) for sourcing the HDMI power line. The TPD5S115 exceeds the IEC61000-4-2 (Level 4) ESD protection level.

**7.5.4.4 HDMI ESD Protection Device (Required)**

Interfaces that connect to a cable such as HDMI generally require more ESD protection than can be built into the processor’s outputs. Therefore this HDMI interface requires the use of an ESD protection chip to provide adequate ESD.

When selecting an ESD protection chip, choose the lowest capacitance ESD protection available to minimize signal degradation. In no case should be ESD protection circuit capacitance be more than 5pF.

TI manufactures these devices that provide ESD protection for HDMI signals such as the TPDxE05U06. For more information see the [www.ti.com](http://www.ti.com) website.

**7.5.4.5 PCB Stackup Specifications**

Table 7-15 shows the stackup and feature sizes required for HDMI.

**Table 7-15. HDMI PCB Stackup Specifications**

PARAMETER	MIN	TYP	MAX	UNIT
PCB Routing/Plane Layers	4	6	-	Layers

**Table 7-15. HDMI PCB Stackup Specifications (continued)**

PARAMETER	MIN	TYP	MAX	UNIT
Signal Routing Layers	2	3	-	Layers
Number of ground plane cuts allowed within HDMI routing region	-	-	0	Cuts
Number of layers between HDMI routing region and reference ground plane	-	-	0	Layers
PCB Trace width		4		Mils

#### 7.5.4.6 Grounding

Each TMDS channel has its own shield pin and they should be grounded to provide a return current path for the TMDS signal.

#### 7.5.5 PCIe Board Design and Layout Guidelines

The PCIe interface on the device provides support for a 5.0 Gbps lane with polarity inversion.

##### 7.5.5.1 PCIe Connections and Interface Compliance

The PCIe interface on the device is compliant with the PCIe revision 3.0 specification. Please refer to the PCIe specifications for all connections that are described in it. Those recommendations are more descriptive and exhaustive than what is possible here.

The use of PCIe compatible bridges and switches is allowed for interfacing with more than one other processor or PCIe device.

##### 7.5.5.1.1 Coupling Capacitors

AC coupling capacitors are required on the transmit data pair. [Table 7-16](#) shows the requirements for these capacitors.

**Table 7-16. PCIe AC Coupling Capacitors Requirements**

PARAMETER	MIN	TYP	MAX	UNIT
PCIe AC coupling capacitor value	90	100	110	nF
PCIe AC coupling capacitor package size		0402	0603	EIA <sup>(1)(2)</sup>

(1) EIA LxW units, i.e., a 0402 is a 40x20 mils surface mount capacitor.

(2) The physical size of the capacitor should be as small as practical. Use the same size on both lines in each pair placed side by side.

##### 7.5.5.1.2 Polarity Inversion

The PCIe specification requires polarity inversion support. This means for layout purposes, polarity is unimportant because each signal can change its polarity on die inside the chip. This means polarity within a lane is unimportant for layout.

##### 7.5.5.2 Non-standard PCIe connections

The following sections contain suggestions for any PCIe connection that is NOT described in the official PCIe specification, such as an on-board Device to Device or Device to other PCIe compliant processor connection.

##### 7.5.5.2.1 PCB Stackup Specifications

[Table 7-17](#) shows the stackup and feature sizes required for these types of PCIe connections.

**Table 7-17. PCIe PCB Stackup Specifications**

PARAMETER	MIN	TYP	MAX	UNIT
Number of ground plane cuts allowed within PCIe routing region	-	-	0	Cuts
Number of layers between PCIe routing area and reference plane <sup>(1)</sup>	-	-	0	Layers
PCB Routing clearance		4		Mils
PCB Trace width		4		Mils

(1) A reference plane may be a ground plane or the power plane referencing the PCIe signals.

### 7.5.5.2.2 Routing Specifications

#### 7.5.5.2.2.1 Impedance

The PCIe data signal traces must be routed to achieve 100- $\Omega$  ( $\pm 10\%$ ) differential impedance and 60- $\Omega$  ( $\pm 10\%$ ) single-ended impedance. The single-ended impedance is required because differential signals are extremely difficult to closely couple on PCBs and, therefore, single-ended impedance becomes important. These requirements are the same as those recommended in the PCIe Motherboard Checklist 1.0 document, available from PCI-SIG ([www.pcisig.com](http://www.pcisig.com)).

These impedances are impacted by trace width, trace spacing, distance between signals and referencing planes, and dielectric material. Verify with a PCB design tool that the trace geometry for both data signal pairs result in as close to 100- $\Omega$  differential impedance and 60- $\Omega$  single-ended impedance as possible. For best accuracy, work with your PCB fabricator to ensure this impedance is met. See [Table 7-18](#) below.

#### 7.5.5.2.2.2 Differential Coupling

In general, closely coupled differential signal traces are not an advantage on PCBs. When differential signals are closely coupled, tight spacing and width control is necessary. Very small width and spacing variations affect impedance dramatically, so tight impedance control can be more problematic to maintain in production. For PCBs with very tight space limitations (which are usually small) this can work, but for most PCBs, the loosely coupled option is probably best.

Loosely coupled PCB differential signals make impedance control much easier. Wider traces and spacing make obstacle avoidance easier (because each trace is not so fixed in position relative to the other), and trace width variations don't affect impedance as much, therefore it's easier to maintain an accurate impedance over the length of the signal. For longer routes, the wider traces also show reduced skin effect and therefore often result in better signal integrity with a larger eye diagram opening.

[Table 7-18](#) shows the routing specifications for the PCIe data signals.

**Table 7-18. PCI-E Routing Specifications**

PARAMETER	MIN	TYP	MAX	UNIT
PCIe signal trace length (device balls to PCIe connector)			4700 <sup>(1)</sup>	Mils
Differential pair trace matching			5 <sup>(2)</sup>	Mils
Number of stubs allowed on PCIe traces <sup>(3)</sup>			0	stubs
TX/RX pair differential impedance	90	100	110	$\Omega$
TX/RX single-ended impedance	54	60	66	$\Omega$
Pad size of vias on PCIe trace			25 <sup>(4)</sup>	Mils
Hole size of vias on PCIe trace			14	Mils
Number of vias on each PCIe trace			0	Vias
PCIe differential pair to any other trace spacing	2xDS <sup>(5)</sup>			

- (1) Beyond this, signal integrity may suffer.
- (2) For example, RXP0 within 5 Mils of RXN0.
- (3) Inline pads may be used for probing.
- (4) 35-Mil antipad maximum recommended.
- (5) DS = differential spacing of the PCIe traces.

**Table 7-19. PCIe Routing Recommendations**

Item	Description	Reason
ESD part number	None	ESD suppression generally not used on PCIe

### 7.5.5.2.3 Pair Length Matching

Each signal in the differential pair should be matched to within 5 mils of its matching differential signal. Length matching should be done as close to the mismatch as possible.

### 7.5.5.3 LJCB\_REFN/P Connections

A Common Refclk Rx Architecture is required to be used for the device PCIe interface. Specifically, two modes of Common Refclk Rx Architecture are supported:

- **External REFCLK Mode:** An common external 100MHz clock source is distributed to both the Device and the link partner
- **Output REFCLK Mode:** A 100MHz HCSL clock source is output by the device and used by the link partner

In **External REFCLK Mode**, a high-quality, low-jitter, differential HCSL 100MHz clock source compliant to the PCIe REFCLK AC Specifications should be provided on the Device's ljcb\_clkn / ljcb\_clkp inputs. Alternatively, an LVDS clock source can be used with the following additional requirements:

- External AC coupling capacitors described in [Table 7-20](#) should be populated at the ljcb\_clkn / ljcb\_clkp inputs.
- All termination requirements (ex. parallel 100ohm termination) from the clock source manufacturer should be followed.

In **Output REFCLK Mode**, the 100MHz clock from the Device's DPLL\_PCIE\_REF should be output on the Device's ljcb\_clkn / ljcb\_clkp pins and used as the HCSL REFCLK by the link partner. External near-side termination to ground described in [Table 7-21](#) is required on both of the ljcb\_clkn / ljcb\_clkp outputs in this mode.

**Table 7-20. LJCB\_REFN/P Requirements in External LVDS REFCLK Mode**

PARAMETER	MIN	TYP	MAX	UNIT
ljcb_clkn / ljcb_clkp AC coupling capacitor value		100		nF
ljcb_clkn / ljcb_clkp AC coupling capacitor package size		0402	0603	EIA <sup>(1)(2)</sup>

(1) EIA LxW units, i.e., a 0402 is a 40x20 mils surface mount capacitor.

(2) The physical size of the capacitor should be as small as practical. Use the same size on both lines in each pair placed side by side.

**Table 7-21. LJCB\_REFN/P Requirements in Output REFCLK Mode**

PARAMETER	MIN	TYP	MAX	UNIT
ljcb_clkn / ljcb_clkp near-side termination to ground value	47.5	50	52.5	Ohms

### 7.5.6 CSI2 Board Design and Routing Guidelines

The MIPI D-PHY signals include the CSI2\_0 camera serial interfaces to or from the Device.

For more information regarding the MIPI-PHY signals and corresponding balls, see [Table 4-5, CSI2 Signal Descriptions](#).

For more information, you can also see the MIPI D-PHY specification v1-01-00\_r0-03 (specifically the Interconnect and Lane Configuration and Annex B Interconnect Design Guidelines chapters).

In the next section, the PCB guidelines of the following differential interfaces are presented:

- CSI2\_0 CSI-2 at 1.5 Gbps

Table 7-22 lists the MIPI D-PHY interface signals in the Device.

**Table 7-22. MIPI D-PHY Interface Signals in the Device**

SIGNAL NAME	BOTTOM BALL	SIGNAL NAME	BOTTOM BALL
csi2_0_dx0	AC1	csi2_0_dy0	AB2
csi2_0_dx1	AD1	csi2_0_dy1	AC2
csi2_0_dx2	AE2	csi2_0_dy2	AD2

### 7.5.6.1 CSI2\_0 MIPI CSI-2 (1.5 Gbps)

#### 7.5.6.1.1 General Guidelines

The general guidelines for the PCB differential lines are:

- Differential trace impedance  $Z_0 = 100 \Omega$  (minimum =  $85 \Omega$ , maximum =  $115 \Omega$ )
- Total conductor length from the Device package pins to the peripheral device package pins is 25 to 30 cm with common FR4 PCB and flex materials.

#### NOTE

Longer interconnect length can be supported at the expense of detailed simulations of the complete link including driver and receiver models.

The general rule of thumb for the space  $S = 2 \times W$  is not designated (see [Figure 7-19, Guard Illustration](#)). It is because although the  $S = 2 \times W$  rule is a good rule of thumb, it is not always the best solution. The electrical performance will be checked with the frequency-domain specification. Even though the designer does not follow the  $S = 2 \times W$  rule, the differential lines are ok if the lines satisfy the frequency-domain specification.

Because the MIPI signals are used for low-power, single-ended signaling in addition to their high-speed differential implementation, the pairs must be loosely coupled.

#### 7.5.6.1.2 Length Mismatch Guidelines

##### 7.5.6.1.2.1 CSI2\_0 MIPI CSI-2 (1.5 Gbps)

The guidelines of the length mismatch for CSI-2 are presented in [Table 7-23](#).

**Table 7-23. Length Mismatch Guidelines for CSI-2 (1.5 Gbps)**

PARAMETER	TYPICAL VALUE	UNIT
Operating speed	1500	Mbps
UI (bit time)	667	ps
Intralane skew	Have to satisfy mode-conversion S parameters <sup>(1)</sup>	
Interlane skew (UI / 50)	13.34	ps
PCB lane-to-lane skew (0.1 UI)	66.7	ps

(1) sdc12, scd21, scd12, sdc21, scd11, sdc11, scd22, and sdc22

### 7.5.6.1.3 Frequency-domain Specification Guidelines

After the PCB design is finished, the S-parameters of the PCB differential lines will be extracted with a 3D Maxwell Equation Solver such as the high-frequency structure simulator (HFSS) or equivalent, and compared to the frequency-domain specification as defined in the section 7 of the MIPI Alliance Specification for D-PHY Version v1-01-00\_r0-03.

If the PCB lines satisfy the frequency-domain specification, the design is finished. Otherwise, the design needs to be improved.

## 7.6 Clock Routing Guidelines

### 7.6.1 Oscillator Ground Connection

Although the impedance of a ground plane is low it is, of course, not zero. Therefore, any noise current in the ground plane causes a voltage drop in the ground.

Figure 7-36 shows the grounding scheme for high-frequency clock.

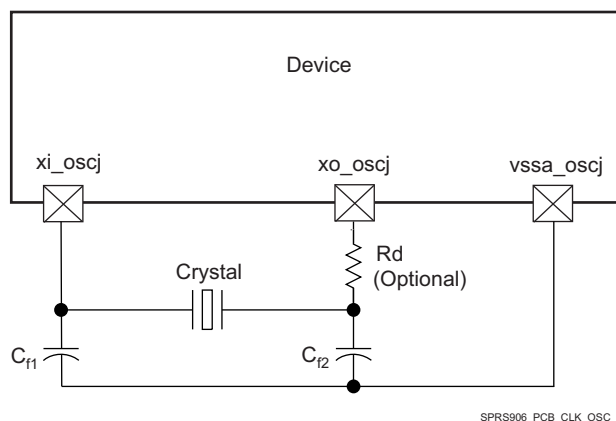

(1) j in \*\_osc = 0 or 1

Figure 7-36. Grounding Scheme for High-Frequency Clock

## 7.7 DDR3 Board Design and Layout Guidelines

### 7.7.1 DDR3 General Board Layout Guidelines

To help ensure good signaling performance, consider the following board design guidelines:

- Avoid crossing splits in the power plane.
- Minimize Vref noise.
- Use the widest trace that is practical between decoupling capacitors and memory module.
- Maintain a single reference.
- Minimize ISI by keeping impedances matched.
- Minimize crosstalk by isolating sensitive bits, such as strobes, and avoiding return path discontinuities.
- Use proper low-pass filtering on the Vref pins.
- Keep the stub length as short as possible.
- Add additional spacing for on-clock and strobe nets to eliminate crosstalk.
- Maintain a common ground reference for all bypass and decoupling capacitors.
- Take into account the differences in propagation delays between microstrip and stripline nets when evaluating timing constraints.

## 7.7.2 DDR3 Board Design and Layout Guidelines

### 7.7.2.1 Board Designs

TI only supports board designs using DDR3 memory that follow the guidelines in this document. The switching characteristics and timing diagram for the DDR3 memory controller are shown in [Table 7-24](#) and [Figure 7-37](#).

**Table 7-24. Switching Characteristics Over Recommended Operating Conditions for DDR3 Memory Controller**

NO.	PARAMETER		MIN	MAX	UNIT
1	$t_{c(DDR\_CLK)}$	Cycle time, DDR_CLK	1.5	2.5 <sup>(1)</sup>	ns

(1) This is the absolute maximum the clock period can be. Actual maximum clock period may be limited by DDR3 speed grade and operating frequency (see the DDR3 memory device data sheet).

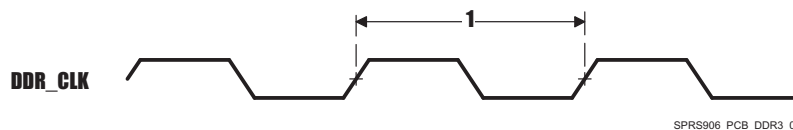

**Figure 7-37. DDR3 Memory Controller Clock Timing**

### 7.7.2.2 DDR3 EMIF

The processor contains one DDR3 EMIF with one chip select.

### 7.7.2.3 DDR3 Device Combinations

Because there are several possible combinations of device counts and single- or dual-side mounting, [Table 7-25](#) summarizes the supported device configurations.

**Table 7-25. Supported DDR3 Device Combinations**

NUMBER OF DDR3 DEVICES	DDR3 DATA DEVICE WIDTH (BITS)	MIRRORED?	DDR3 EMIF WIDTH (BITS)
1	16	N	16
2	8	Y <sup>(1)</sup>	16
2	16	N	32
2	16	Y <sup>(1)</sup>	32
3	16	N <sup>(3)(4)</sup>	32
4	8	N	32
4	8	Y <sup>(2)</sup>	32
5	8	N <sup>(3)(4)</sup>	32

- (1) Two DDR3 devices are mirrored when one device is placed on the top of the board and the second device is placed on the bottom of the board.
- (2) This is two mirrored pairs of DDR3 devices.
- (3) Three or five DDR3 device combination is not available on this device, but combination types are retained for consistency with the DRA7xx family of devices.
- (4) The DDR memory connected to the DDR ECC bus does NOT need to be the same part number as the DDR memories connected to the DDR data bus. However, some constraints do apply. When selecting a memory for the DDR ECC bus, the following restrictions must be adhered to as compared to the DDR memories on the data bus:
  - Match the same DDR3 speed grade
  - Have an equal number of internal banks
  - Have an equal number of columns
  - Have a greater or equal number of rows



## 7.7.2.4 DDR3 Interface Schematic

### 7.7.2.4.1 32-Bit DDR3 Interface

The DDR3 interface schematic varies, depending upon the width of the DDR3 devices used and the width of the bus used (16 or 32 bits). General connectivity is straightforward and very similar. 16-bit DDR devices look like two 8-bit devices. [Figure 7-38](#) and [Figure 7-39](#) show the schematic connections for 32-bit interfaces using x16 devices.

### 7.7.2.4.2 16-Bit DDR3 Interface

Note that the 16-bit wide interface schematic is practically identical to the 32-bit interface (see [Figure 7-38](#) and [Figure 7-39](#)); only the high-word DDR memories are removed and the unused DQS inputs are tied off.

When not using all or part of a DDR interface, the proper method of handling the unused pins is to tie off the `ddrx_dqsi` pins to ground via a 1k-Ω resistor and to tie off the `ddrx_dqsn` pins to the corresponding `vdds_ddrx` supply via a 1k-Ω resistor. This needs to be done for each byte not used. Although these signals have internal pullups and pulldowns, external pullups and pulldowns provide additional protection against external electrical noise causing activity on the signals.

The `vdds_ddrx` and `ddrx_vref0` power supply pins need to be connected to their respective power supplies even if `ddrx` is not being used. All other DDR interface pins can be left unconnected. Note that the supported modes for use of the DDR EMIF are 32-bits wide, 16-bits wide, or not used.

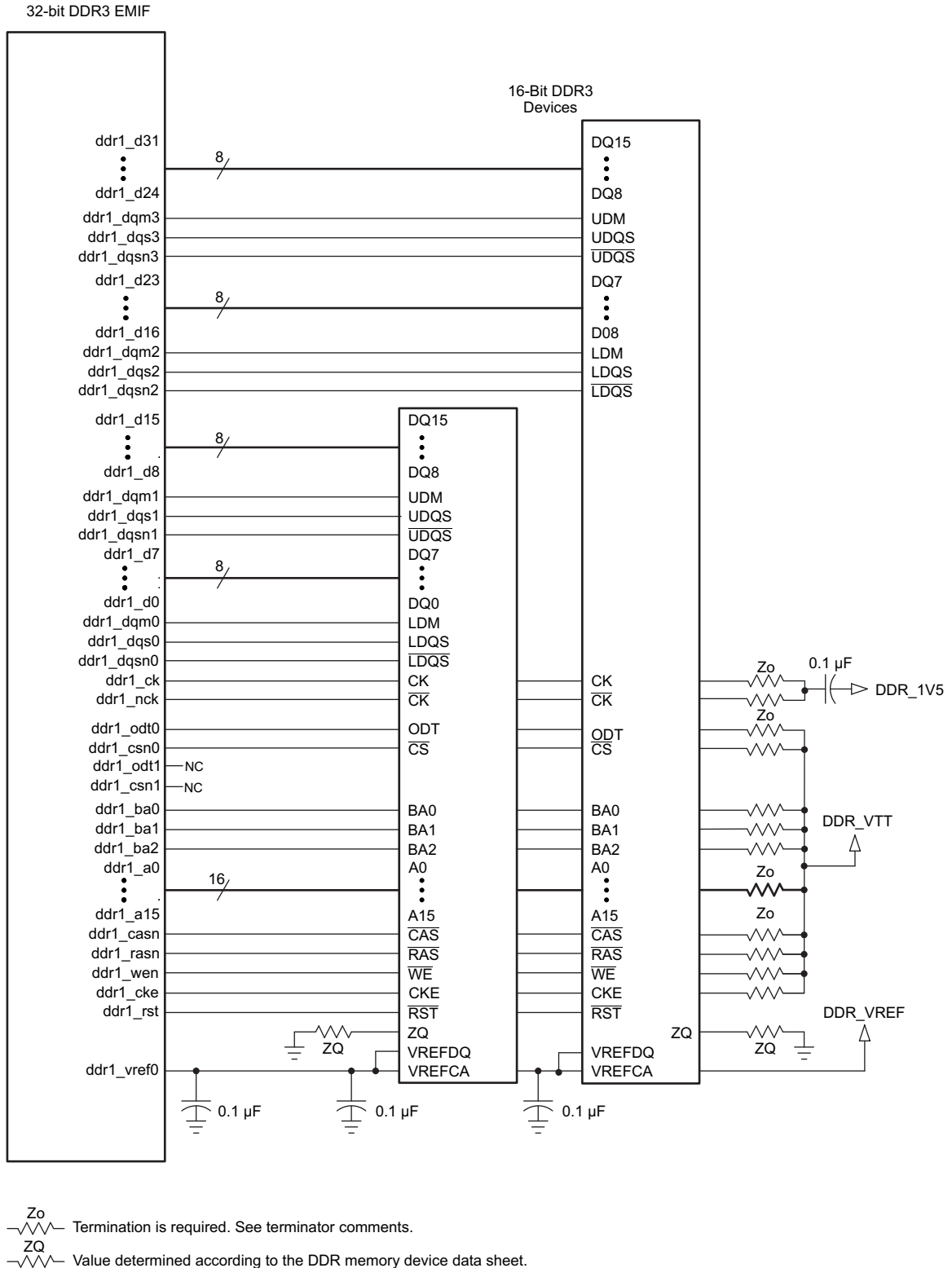

SPRS906\_PCB\_DDR3\_02

Figure 7-38. 32-Bit, One-Bank DDR3 Interface Schematic Using Two 16-Bit DDR3 Devices

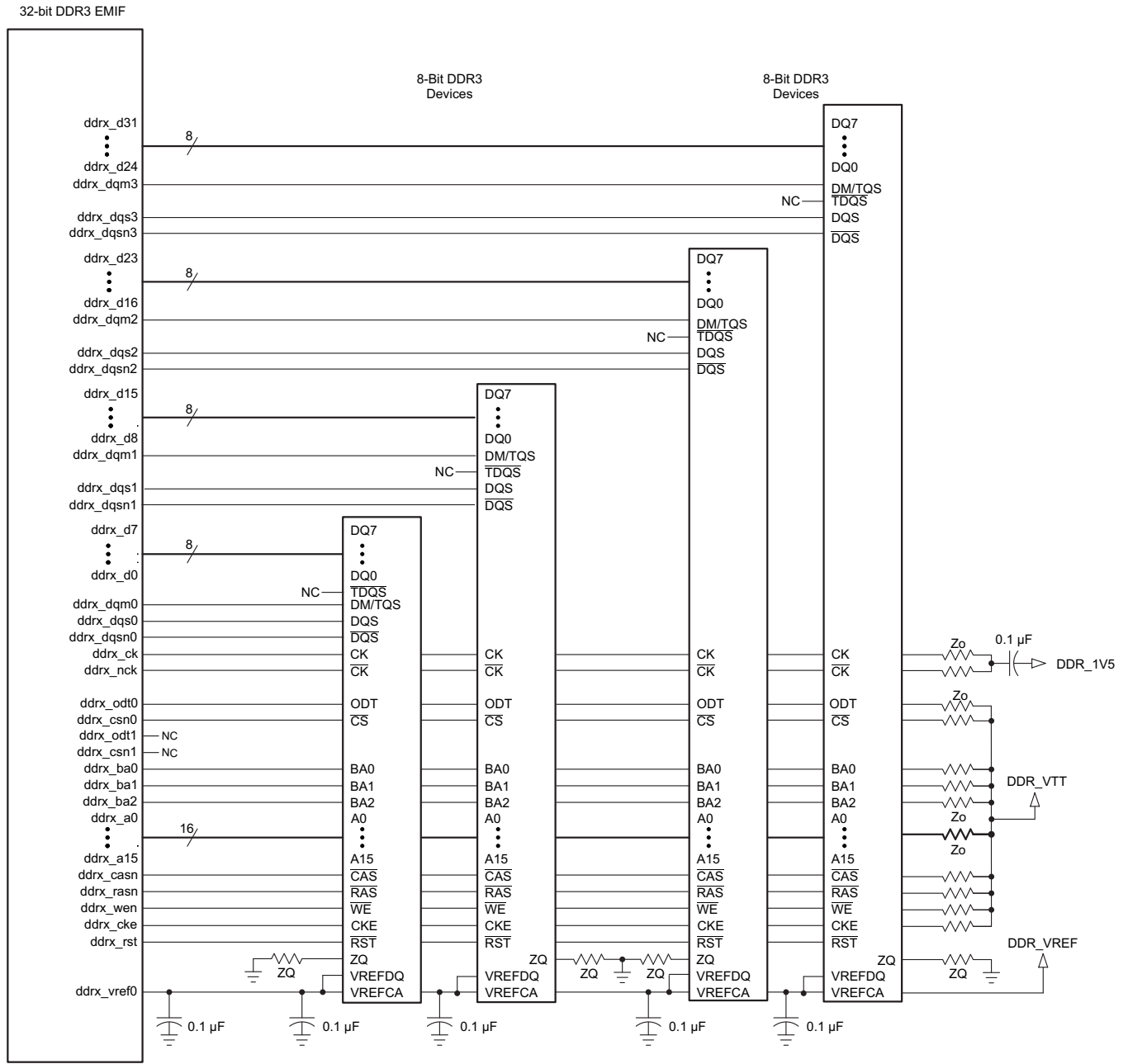

$Z_0$  Termination is required. See terminator comments.  
 $Z_Q$  Value determined according to the DDR memory device data sheet.

SPRS906\_PCB\_DDR3\_03

Figure 7-39. 32-Bit, One-Bank DDR3 Interface Schematic Using Four 8-Bit DDR3 Devices

### 7.7.2.5 Compatible JEDEC DDR3 Devices

Table 7-26 shows the parameters of the JEDEC DDR3 devices that are compatible with this interface. Generally, the DDR3 interface is compatible with DDR3-1333 devices in the x8 or x16 widths.

**Table 7-26. Compatible JEDEC DDR3 Devices (Per Interface)**

N O.	PARAMETER	CONDITION	MIN	MAX	UNIT
1	JEDEC DDR3 device speed grade <sup>(1)</sup>	DDR clock rate = 400MHz	DDR3-800	DDR3-1600	
		400MHz < DDR clock rate ≤ 533MHz	DDR3-1066	DDR3-1600	
		533MHz < DDR clock rate ≤ 667MHz	DDR3-1333	DDR3-1600	
2	JEDEC DDR3 device bit width		x8	x16	Bits
3	JEDEC DDR3 device count <sup>(2)</sup>		2	4	Devices

(1) Refer to Table 7-24 Switching Characteristics Over Recommended Operating Conditions for DDR3 Memory Controller for the range of supported DDR clock rates.

(2) For valid DDR3 device configurations and device counts, see Section 7.7.2.4, Figure 7-38, and Figure 7-39.

### 7.7.2.6 PCB Stackup

The minimum stackup for routing the DDR3 interface is a six-layer stack up as shown in Table 7-27. Additional layers may be added to the PCB stackup to accommodate other circuitry, enhance SI/EMI performance, or to reduce the size of the PCB footprint. Complete stackup specifications are provided in Table 7-28.

**Table 7-27. Six-Layer PCB Stackup Suggestion**

LAYER	TYPE	DESCRIPTION
1	Signal	Top routing mostly vertical
2	Plane	Ground
3	Plane	Split power plane
4	Plane	Split power plane or Internal routing
5	Plane	Ground
6	Signal	Bottom routing mostly horizontal

**Table 7-28. PCB Stackup Specifications**

NO.	PARAMETER	MIN	TYP	MAX	UNIT
PS1	PCB routing/plane layers	6			
PS2	Signal routing layers	3			
PS3	Full ground reference layers under DDR3 routing region <sup>(1)</sup>	1			
PS4	Full 1.5-V power reference layers under the DDR3 routing region <sup>(1)</sup>	1			
PS5	Number of reference plane cuts allowed within DDR routing region <sup>(2)</sup>			0	
PS6	Number of layers between DDR3 routing layer and reference plane <sup>(3)</sup>			0	
PS7	PCB routing feature size		4		Mils
PS8	PCB trace width, w		4		Mils
PS9	Single-ended impedance, Z <sub>0</sub>	50		75	Ω
PS10	Impedance control <sup>(5)</sup>	Z-5	Z	Z+5	Ω

- (1) Ground reference layers are preferred over power reference layers. Be sure to include bypass caps to accommodate reference layer return current as the trace routes switch routing layers.
- (2) No traces should cross reference plane cuts within the DDR routing region. High-speed signal traces crossing reference plane cuts create large return current paths which can lead to excessive crosstalk and EMI radiation.
- (3) Reference planes are to be directly adjacent to the signal plane to minimize the size of the return current loop.
- (4) An 18-mil pad assumes Via Channel is the most economical BGA escape. A 20-mil pad may be used if additional layers are available for power routing. An 18-mil pad is required for minimum layer count escape.
- (5) Z is the nominal singled-ended impedance selected for the PCB specified by PS9.

**7.7.2.7 Placement**

Figure 7-40 shows the required placement for the processor as well as the DDR3 devices. The dimensions for this figure are defined in Table 7-29. The placement does not restrict the side of the PCB on which the devices are mounted. The ultimate purpose of the placement is to limit the maximum trace lengths and allow for proper routing space. For a 16-bit DDR memory system, the high-word DDR3 devices are omitted from the placement.

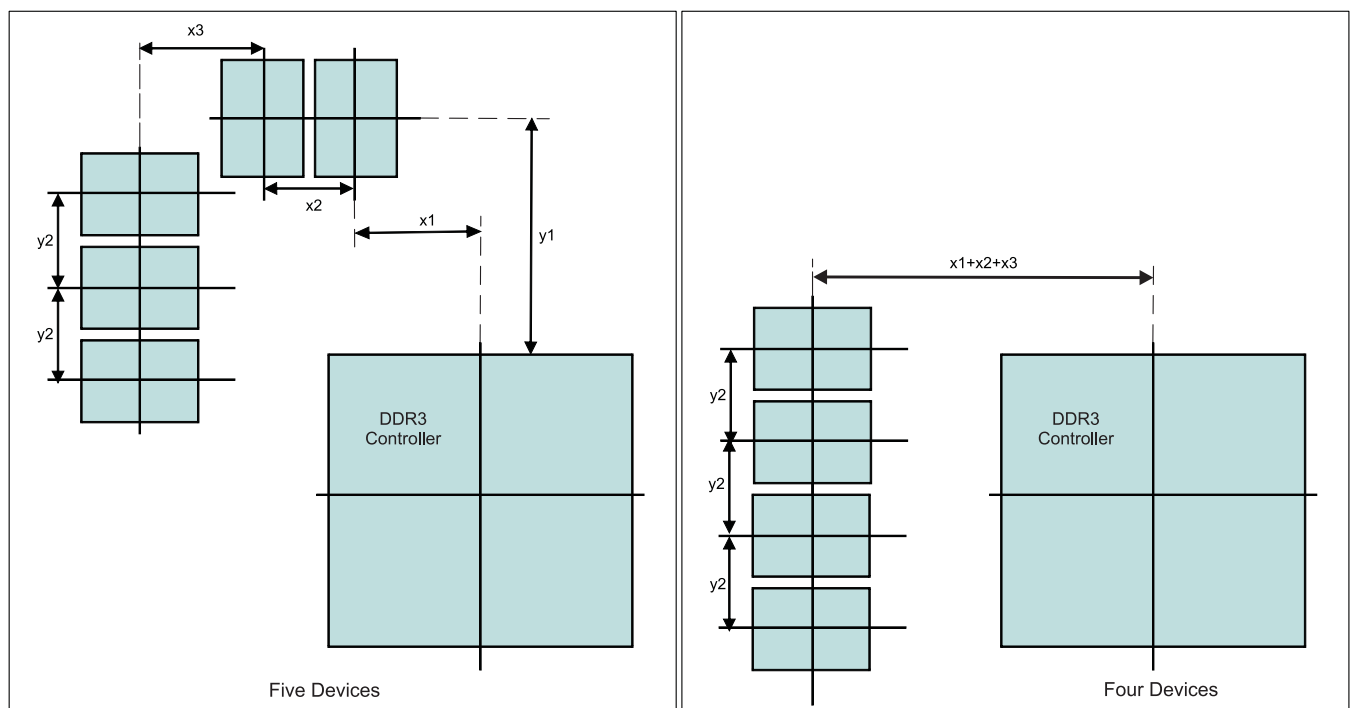

**Figure 7-40. Placement Specifications**

**Table 7-29. Placement Specifications DDR3**

NO.	PARAMETER	MIN	MAX	UNIT
KOD31	X1		500	Mils
KOD32	X2		600	Mils
KOD33	X3		600	Mils
KOD34	Y1		1800	Mils
KOD35	Y2		600	Mils
KOD36	DDR3 keepout region <sup>(1)</sup>			
KOD37	Clearance from non-DDR3 signal to DDR3 keepout region <sup>(2) (3)</sup>	4		W

(1) DDR3 keepout region to encompass entire DDR3 routing area.

(2) Non-DDR3 signals allowed within DDR3 keepout region provided they are separated from DDR3 routing layers by a ground plane.

(3) If a device has more than one DDR controller, the signals from the other controller(s) are considered non-DDR3 and should be separated by this specification.

### 7.7.2.8 DDR3 Keepout Region

The region of the PCB used for DDR3 circuitry must be isolated from other signals. The DDR3 keepout region is defined for this purpose and is shown in [Figure 7-41](#). The size of this region varies with the placement and DDR routing. Additional clearances required for the keepout region are shown in [Table 7-29](#). Non-DDR3 signals should not be routed on the DDR signal layers within the DDR3 keepout region. Non-DDR3 signals may be routed in the region, provided they are routed on layers separated from the DDR signal layers by a ground layer. No breaks should be allowed in the reference ground layers in this region. In addition, the 1.5-V DDR3 power plane should cover the entire keepout region. Also note that the two signals from the DDR3 controller should be separated from each other by the specification in [Table 7-29](#) (see [KOD37](#)).

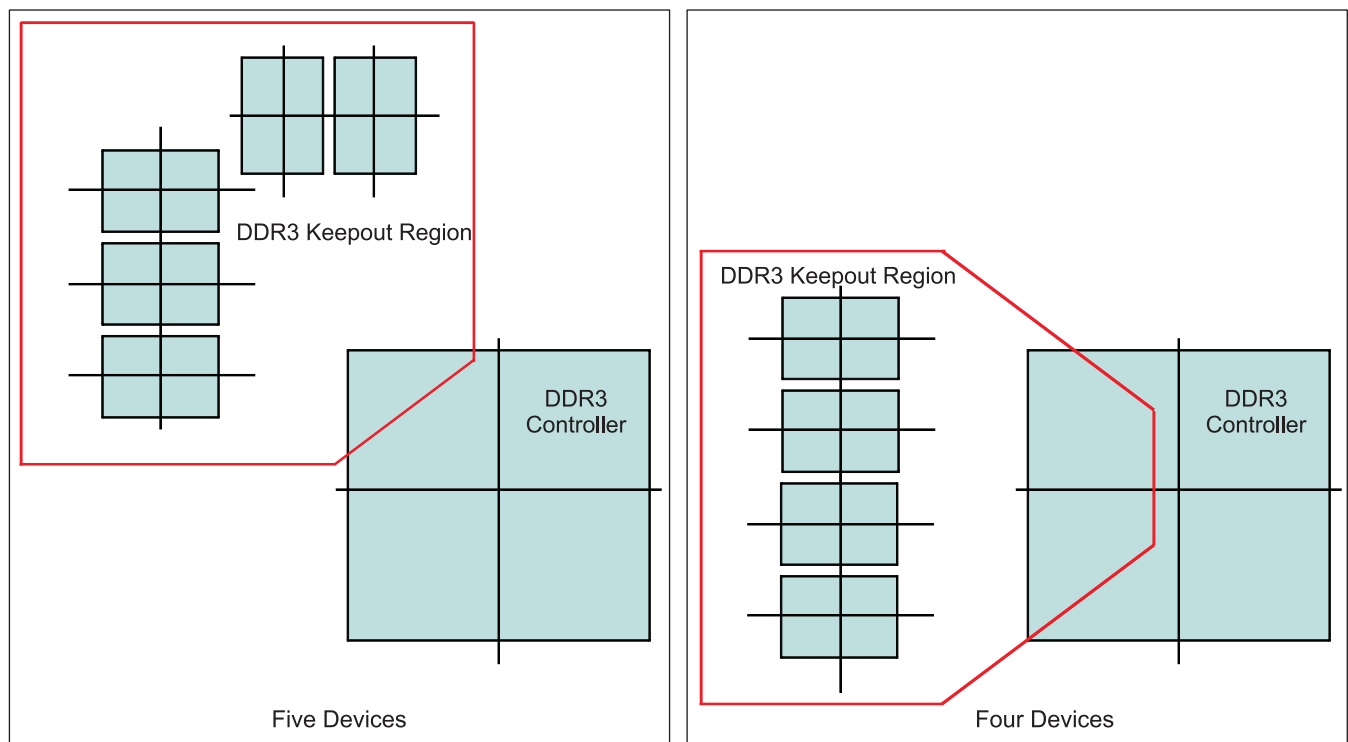

SPRS906\_PCB\_DDR3\_05

**Figure 7-41. DDR3 Keepout Region**

### 7.7.2.9 Bulk Bypass Capacitors

Bulk bypass capacitors are required for moderate speed bypassing of the DDR3 and other circuitry. [Table 7-30](#) contains the minimum numbers and capacitance required for the bulk bypass capacitors. Note that this table only covers the bypass needs of the DDR3 controllers and DDR3 devices. Additional bulk bypass capacitance may be needed for other circuitry.

**Table 7-30. Bulk Bypass Capacitors**

NO.	PARAMETER	MIN	MAX	UNIT
1	vdds_ddrx bulk bypass capacitor count <sup>(1)</sup>	1		Devices
2	vdds_ddrx bulk bypass total capacitance	22		μF

(1) These devices should be placed near the devices they are bypassing, but preference should be given to the placement of the high-speed (HS) bypass capacitors and DDR3 signal routing.

### 7.7.2.10 High-Speed Bypass Capacitors

High-speed (HS) bypass capacitors are critical for proper DDR3 interface operation. It is particularly important to minimize the parasitic series inductance of the HS bypass capacitors, processor/DDR power, and processor/DDR ground connections. [Table 7-31](#) contains the specification for the HS bypass capacitors as well as for the power connections on the PCB. Generally speaking, it is good to:

1. Fit as many HS bypass capacitors as possible.
2. Minimize the distance from the bypass cap to the pins/balls being bypassed.
3. Use the smallest physical sized capacitors possible with the highest capacitance readily available.
4. Connect the bypass capacitor pads to their vias using the widest traces possible and using the largest hole size via possible.
5. Minimize via sharing. Note the limites on via sharing shown in [Table 7-31](#).

**Table 7-31. High-Speed Bypass Capacitors**

NO.	PARAMETER	MIN	TYP	MAX	UNIT
1	HS bypass capacitor package size <sup>(1)</sup>		0201	0402	10 Mils
2	Distance, HS bypass capacitor to processor being bypassed <sup>(2)(3)(4)</sup>			400	Mils
3	Processor HS bypass capacitor count per vdds_ddrx rail <sup>(12)</sup>		See <a href="#">Table 7-3</a> and <sup>(11)</sup>		Devices
4	Processor HS bypass capacitor total capacitance per vdds_ddrx rail <sup>(12)</sup>		See <a href="#">Table 7-3</a> and <sup>(11)</sup>		μF
5	Number of connection vias for each device power/ground ball <sup>(5)</sup>				Vias
6	Trace length from device power/ground ball to connection via <sup>(2)</sup>		35	70	Mils
7	Distance, HS bypass capacitor to DDR device being bypassed <sup>(6)</sup>			150	Mils
8	DDR3 device HS bypass capacitor count <sup>(7)</sup>	12			Devices
9	DDR3 device HS bypass capacitor total capacitance <sup>(7)</sup>	0.85			μF
10	Number of connection vias for each HS capacitor <sup>(8)(9)</sup>	2			Vias
11	Trace length from bypass capacitor connect to connection via <sup>(2)(9)</sup>		35	100	Mils
12	Number of connection vias for each DDR3 device power/ground ball <sup>(10)</sup>	1			Vias
13	Trace length from DDR3 device power/ground ball to connection via <sup>(2)(8)</sup>		35	60	Mils

(1) LxW, 10-mil units, that is, a 0402 is a 40x20-mil surface-mount capacitor.

(2) Closer/shorter is better.

(3) Measured from the nearest processor power/ground ball to the center of the capacitor package.

(4) Three of these capacitors should be located underneath the processor, between the cluster of DDR\_1V5 balls and ground balls, between the DDR interfaces on the package.

(5) See the Via Channel™ escape for the processor package.

(6) Measured from the DDR3 device power/ground ball to the center of the capacitor package.

(7) Per DDR3 device.

(8) An additional HS bypass capacitor can share the connection vias only if it is mounted on the opposite side of the board. No sharing of vias is permitted on the same side of the board.

- (9) An HS bypass capacitor may share a via with a DDR device mounted on the same side of the PCB. A wide trace should be used for the connection and the length from the capacitor pad to the DDR device pad should be less than 150 mils.
- (10) Up to a total of two pairs of DDR power/ground balls may share a via.
- (11) The capacitor recommendations in this data manual reflect only the needs of this processor. Please see the memory vendor's guidelines for determining the appropriate decoupling capacitor arrangement for the memory device itself.
- (12) For more information, see [Section 7.3, Core Power Domains](#).

### 7.7.2.10.1 Return Current Bypass Capacitors

Use additional bypass capacitors if the return current reference plane changes due to DDR3 signals hopping from one signal layer to another. The bypass capacitor here provides a path for the return current to hop planes along with the signal. As many of these return current bypass capacitors should be used as possible. Because these are returns for signal current, the signal via size may be used for these capacitors.

### 7.7.2.11 Net Classes

[Table 7-32](#) lists the clock net classes for the DDR3 interface. [Table 7-33](#) lists the signal net classes, and associated clock net classes, for signals in the DDR3 interface. These net classes are used for the termination and routing rules that follow.

**Table 7-32. Clock Net Class Definitions**

CLOCK NET CLASS	processor PIN NAMES
CK	ddrx_ck/ddrx_nck
DQS0	ddrx_dqs0 / ddrx_dqsn0
DQS1	ddrx_dqs1 / ddrx_dqsn1
DQS2 <sup>(1)</sup>	ddrx_dqs2 / ddrx_dqsn2
DQS3 <sup>(1)</sup>	ddrx_dqs3 / ddrx_dqsn3

(1) Only used on 32-bit wide DDR3 memory systems.

**Table 7-33. Signal Net Class Definitions**

SIGNAL NET CLASS	ASSOCIATED CLOCK NET CLASS	processor PIN NAMES
ADDR_CTRL	CK	ddrx_ba[2:0], ddrx_a[14:0], ddrx_csnj, ddrx_casn, ddrx_rasn, ddrx_wen, ddrx_cke, ddrx_odti
DQ0	DQS0	ddrx_d[7:0], ddrx_dqm0
DQ1	DQS1	ddrx_d[15:8], ddrx_dqm1
DQ2 <sup>(1)</sup>	DQS2	ddrx_d[23:16], ddrx_dqm2
DQ3 <sup>(1)</sup>	DQS3	ddrx_d[31:24], ddrx_dqm3

(1) Only used on 32-bit wide DDR3 memory systems.

### 7.7.2.12 DDR3 Signal Termination

Signal terminators are required for the CK and ADDR\_CTRL net classes. The data lines are terminated by ODT and, thus, the PCB traces should be unterminated. Detailed termination specifications are covered in the routing rules in the following sections.

### 7.7.2.13 VREF\_DDR Routing

ddrx\_vref0 (VREF) is used as a reference by the input buffers of the DDR3 memories as well as the processor. VREF is intended to be half the DDR3 power supply voltage and is typically generated with the DDR3 VDD5 and VTT power supply. It should be routed as a nominal 20-mil wide trace with 0.1  $\mu$ F bypass capacitors near each device connection. Narrowing of VREF is allowed to accommodate routing congestion.



7.7.2.14 VTT

Like VREF, the nominal value of the VTT supply is half the DDR3 supply voltage. Unlike VREF, VTT is expected to source and sink current, specifically the termination current for the ADDR\_CTRL net class Thevinen terminators. VTT is needed at the end of the address bus and it should be routed as a power sub-plane. VTT should be bypassed near the terminator resistors.

7.7.2.15 CK and ADDR\_CTRL Topologies and Routing Definition

The CK and ADDR\_CTRL net classes are routed in a fly-by topology. They are routed in a similar manner and are length matched to minimize skew between them. CK is a bit more complicated because it runs at a higher transition rate and is differential. The following subsections show the topology and routing for various DDR3 configurations for CK and ADDR\_CTRL. The figures in the following subsections define the terms for the routing specification detailed in Table 7-34. Balanced-T routing is not recommended.

7.7.2.15.1 Four DDR3 Devices

Four DDR3 devices are supported on the DDR EMIF consisting of four x8 DDR3 devices arranged as one bank (CS). These four devices may be mounted on a single side of the PCB, or may be mirrored in two pairs to save board space at a cost of increased routing complexity and parts on the backside of the PCB.

7.7.2.15.1.1 CK and ADDR\_CTRL Topologies, Four DDR3 Devices

Figure 7-42 shows the topology of the CK net classes and Figure 7-43 shows the topology for the corresponding ADDR\_CTRL net classes.

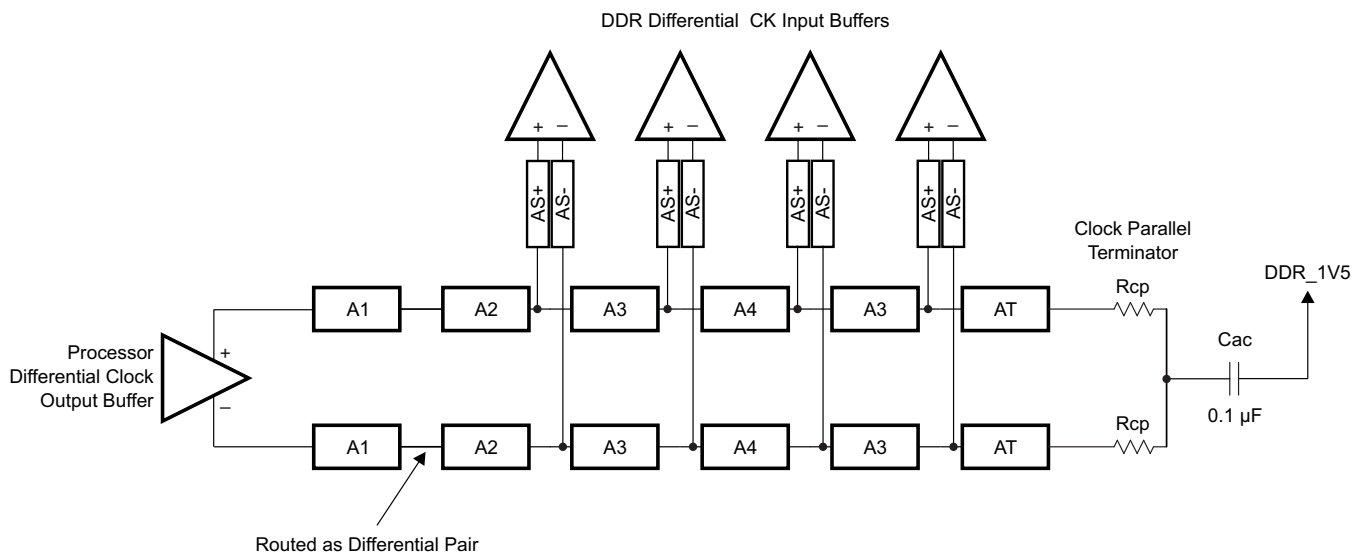

SPRS906\_PCB\_DDR3\_06

Figure 7-42. CK Topology for Four x8 DDR3 Devices

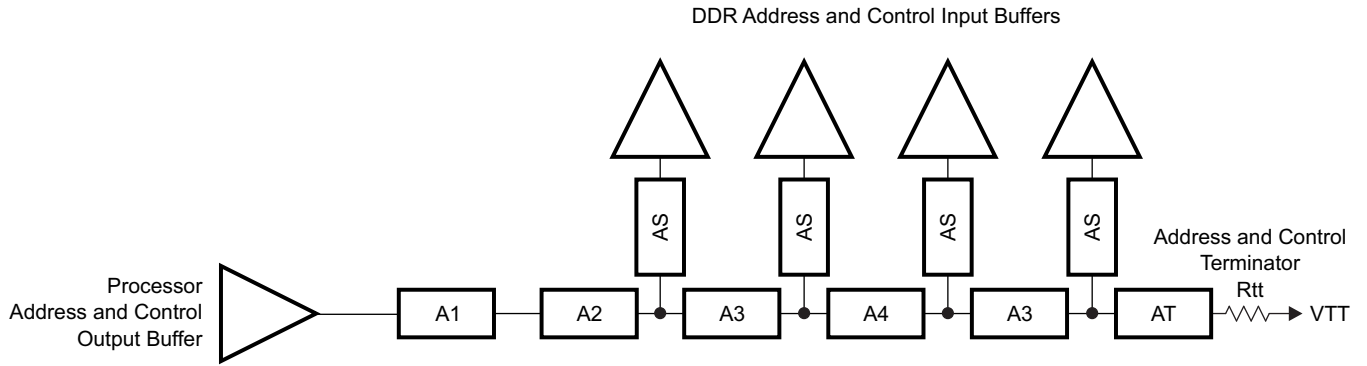

SPRS906\_PCB\_DDR3\_07

Figure 7-43. ADDR\_CTRL Topology for Four x8 DDR3 Devices

7.7.2.15.1.2 CK and ADDR\_CTRL Routing, Four DDR3 Devices

Figure 7-44 shows the CK routing for four DDR3 devices placed on the same side of the PCB. Figure 7-45 shows the corresponding ADDR\_CTRL routing.

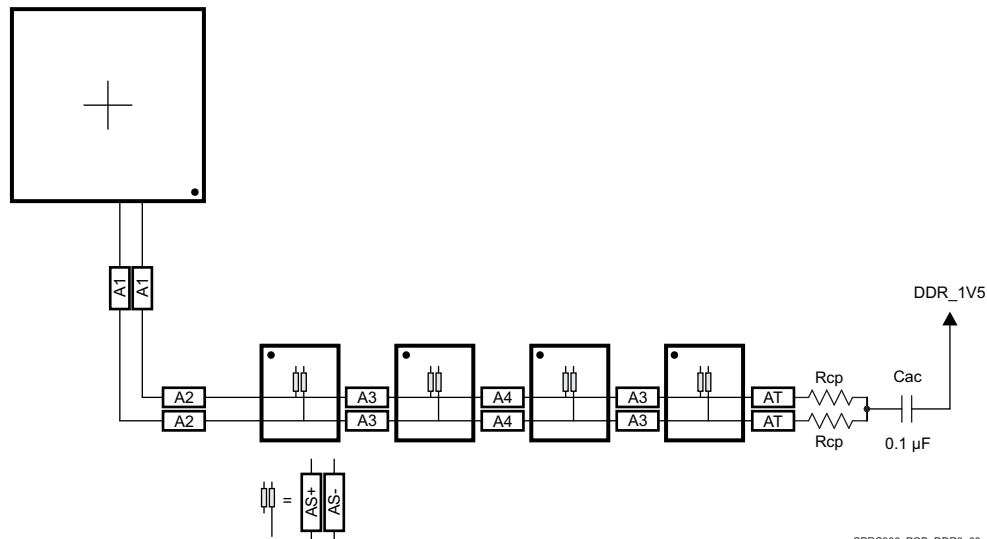

SPRS906\_PCB\_DDR3\_08

Figure 7-44. CK Routing for Four Single-Side DDR3 Devices

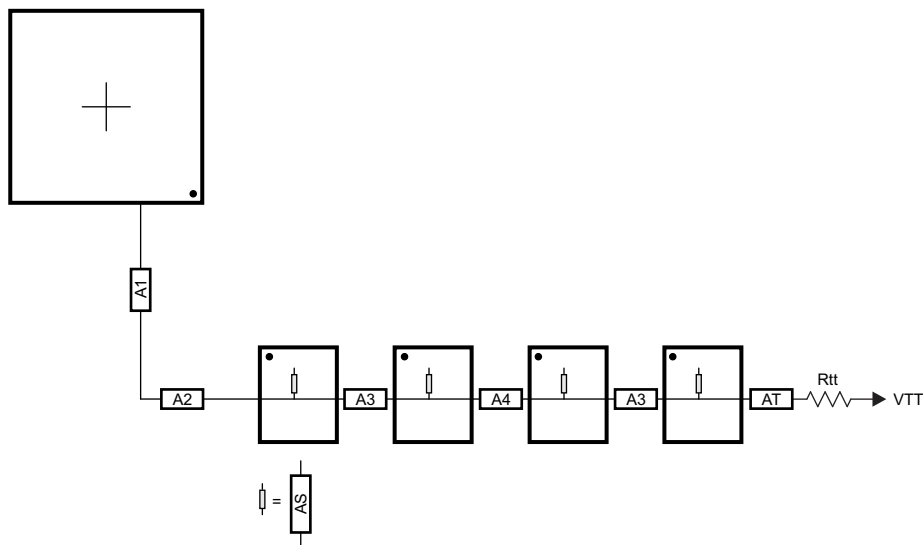

SPRS906\_PCB\_DDR3\_09

Figure 7-45. ADDR\_CTRL Routing for Four Single-Side DDR3 Devices

To save PCB space, the four DDR3 memories may be mounted as two mirrored pairs at a cost of increased routing and assembly complexity. Figure 7-46 and Figure 7-47 show the routing for CK and ADDR\_CTRL, respectively, for four DDR3 devices mirrored in a two-pair configuration.

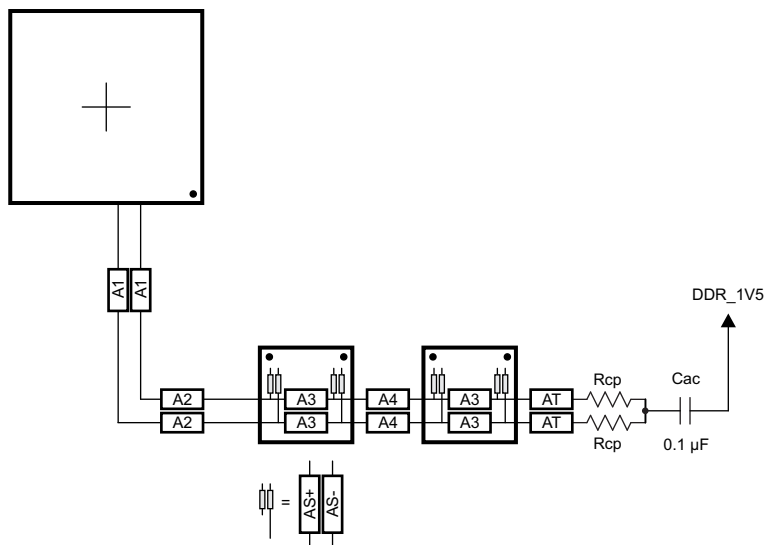

SPRS906\_PCB\_DDR3\_10

Figure 7-46. CK Routing for Four Mirrored DDR3 Devices

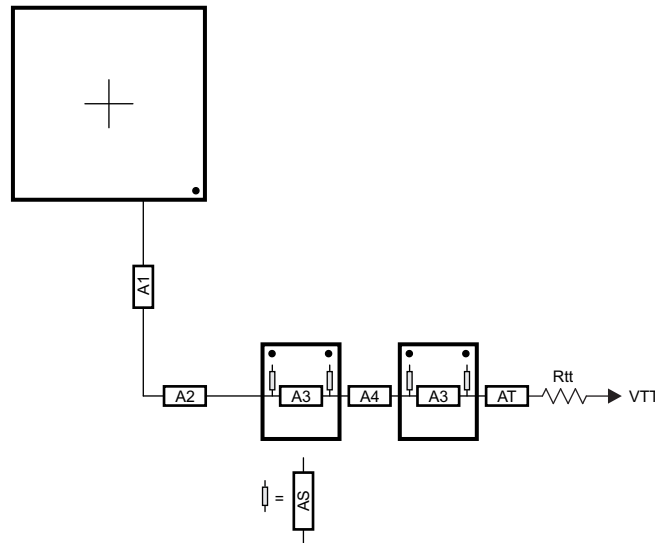

SPRS906\_PCB\_DDR3\_11

Figure 7-47. ADDR\_CTRL Routing for Four Mirrored DDR3 Devices

7.7.2.15.2 Two DDR3 Devices

Two DDR3 devices are supported on the DDR EMIF consisting of two x8 DDR3 devices arranged as one bank (CS), 16 bits wide, or two x16 DDR3 devices arranged as one bank (CS), 32 bits wide. These two devices may be mounted on a single side of the PCB, or may be mirrored in a pair to save board space at a cost of increased routing complexity and parts on the backside of the PCB.

7.7.2.15.2.1 CK and ADDR\_CTRL Topologies, Two DDR3 Devices

Figure 7-48 shows the topology of the CK net classes and Figure 7-49 shows the topology for the corresponding ADDR\_CTRL net classes.

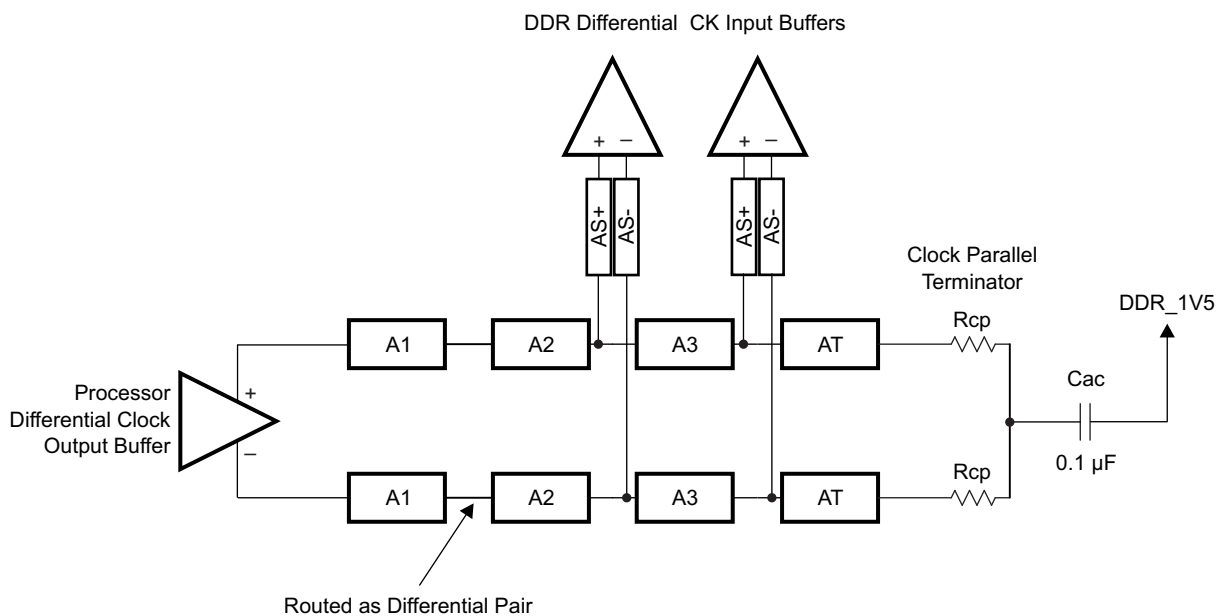

SPRS906\_PCB\_DDR3\_12

Figure 7-48. CK Topology for Two DDR3 Devices

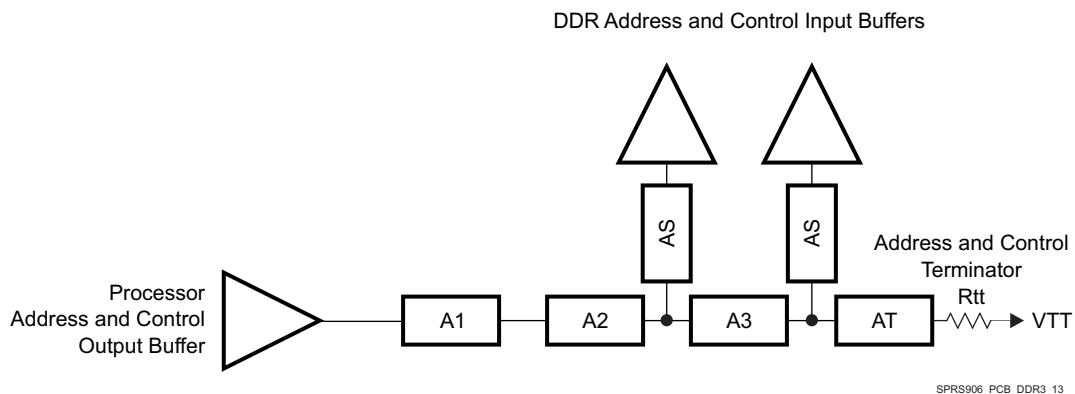

Figure 7-49. ADDR\_CTRL Topology for Two DDR3 Devices

7.7.2.15.2.2 CK and ADDR\_CTRL Routing, Two DDR3 Devices

Figure 7-50 shows the CK routing for two DDR3 devices placed on the same side of the PCB. Figure 7-51 shows the corresponding ADDR\_CTRL routing.

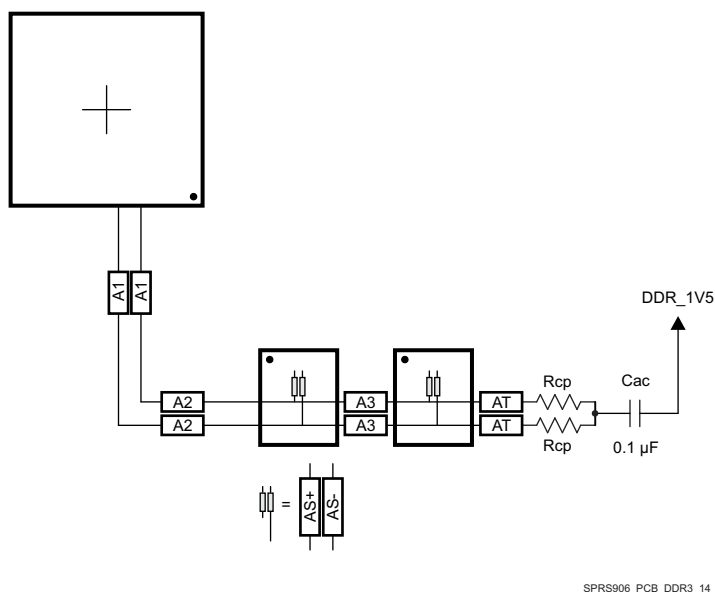
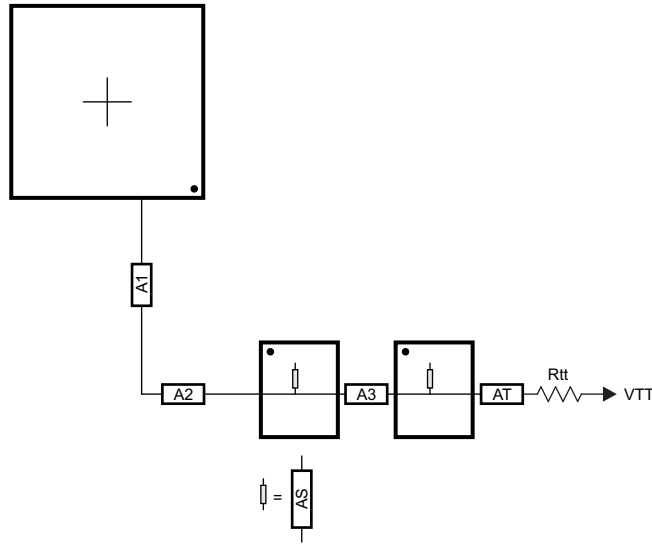

Figure 7-50. CK Routing for Two Single-Side DDR3 Devices



SPRS906\_PCB\_DDR3\_15

**Figure 7-51. ADDR\_CTRL Routing for Two Single-Side DDR3 Devices**

To save PCB space, the two DDR3 memories may be mounted as a mirrored pair at a cost of increased routing and assembly complexity. [Figure 7-52](#) and [Figure 7-53](#) show the routing for CK and ADDR\_CTRL, respectively, for two DDR3 devices mirrored in a single-pair configuration.

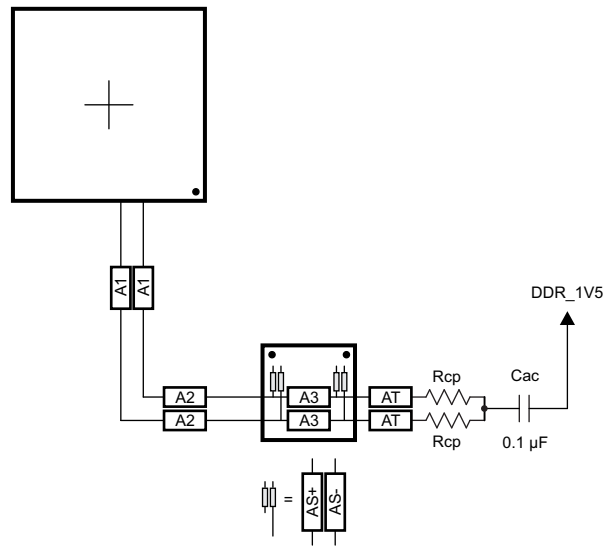

SPRS906\_PCB\_DDR3\_16

**Figure 7-52. CK Routing for Two Mirrored DDR3 Devices**

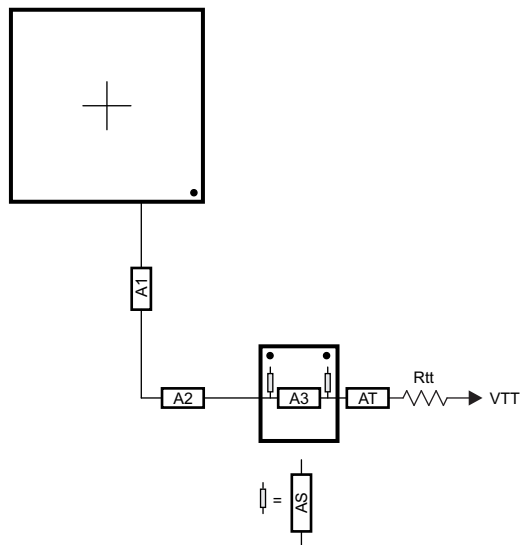

SPRS906\_PCB\_DDR3\_17

Figure 7-53. ADDR\_CTRL Routing for Two Mirrored DDR3 Devices

7.7.2.15.3 One DDR3 Device

A single DDR3 device is supported on the DDR EMIF consisting of one x16 DDR3 device arranged as one bank (CS), 16 bits wide.

7.7.2.15.3.1 CK and ADDR\_CTRL Topologies, One DDR3 Device

Figure 7-54 shows the topology of the CK net classes and Figure 7-55 shows the topology for the corresponding ADDR\_CTRL net classes.

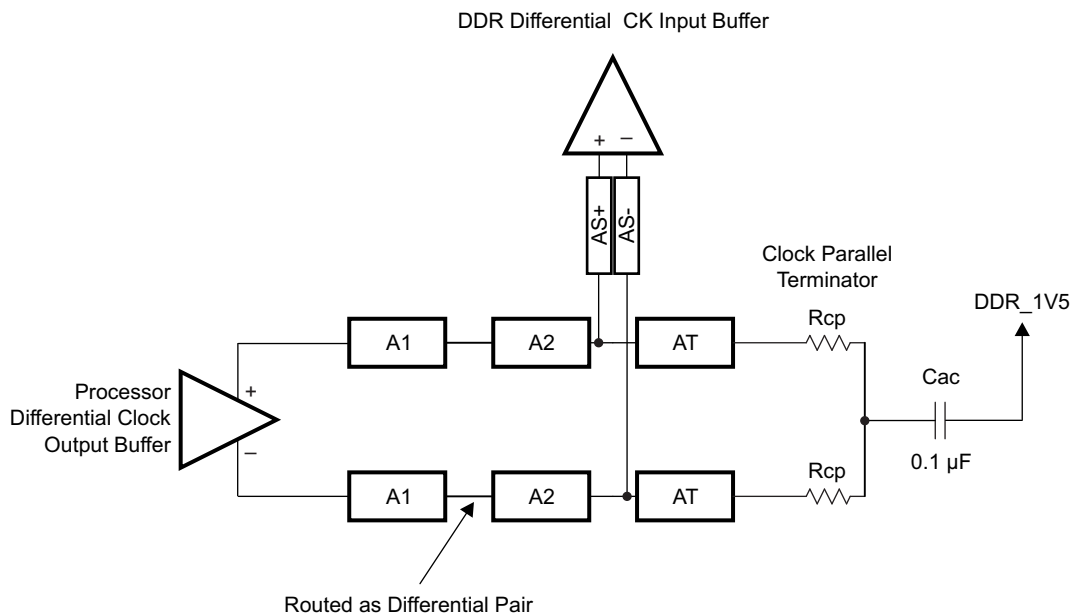

SPRS906\_PCB\_DDR3\_18

Figure 7-54. CK Topology for One DDR3 Device

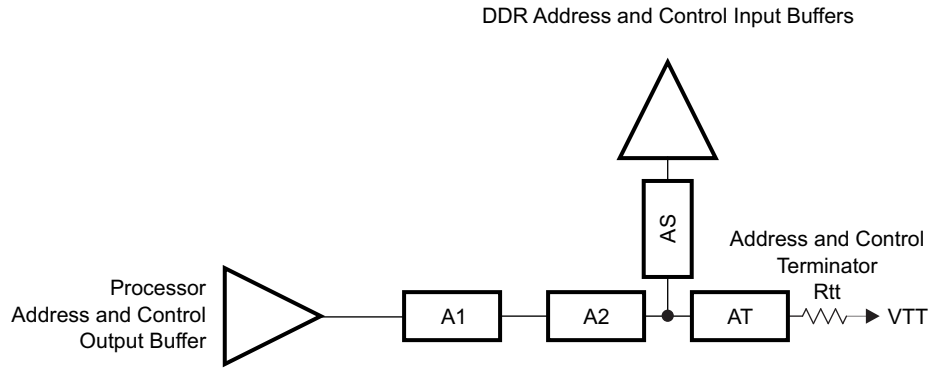

SPRS906\_PCB\_DDR3\_19

Figure 7-55. ADDR\_CTRL Topology for One DDR3 Device

7.7.2.15.3.2 CK and ADDR/CTRL Routing, One DDR3 Device

Figure 7-56 shows the CK routing for one DDR3 device placed on the same side of the PCB. Figure 7-57 shows the corresponding ADDR\_CTRL routing.

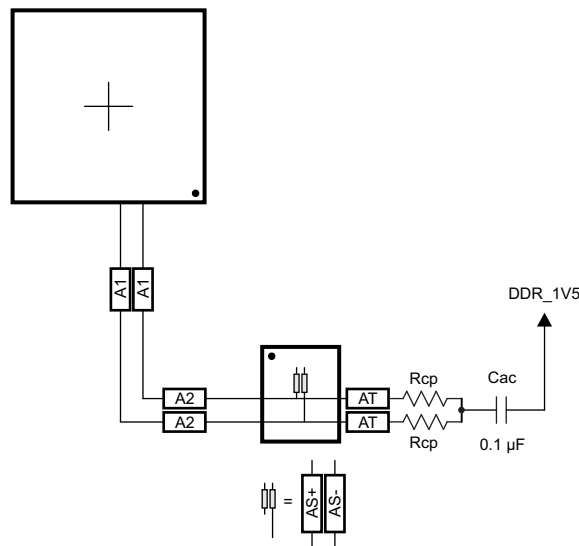

SPRS906\_PCB\_DDR3\_20

Figure 7-56. CK Routing for One DDR3 Device



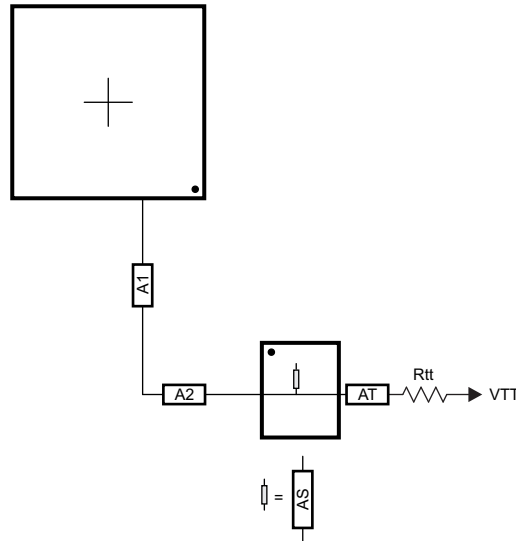

SPRS906\_PCB\_DDR3\_21

Figure 7-57. ADDR\_CTRL Routing for One DDR3 Device

### 7.7.2.16 Data Topologies and Routing Definition

No matter the number of DDR3 devices used, the data line topology is always point to point, so its definition is simple.

Care should be taken to minimize layer transitions during routing. If a layer transition is necessary, it is better to transition to a layer using the same reference plane. If this cannot be accommodated, ensure there are nearby ground vias to allow the return currents to transition between reference planes if both reference planes are ground or vdds\_ddr. Ensure there are nearby bypass capacitors to allow the return currents to transition between reference planes if one of the reference planes is ground. The goal is to minimize the size of the return current loops.

#### 7.7.2.16.1 DQS and DQ/DM Topologies, Any Number of Allowed DDR3 Devices

DQS lines are point-to-point differential, and DQ/DM lines are point-to-point singled ended. Figure 7-58 and Figure 7-59 show these topologies.

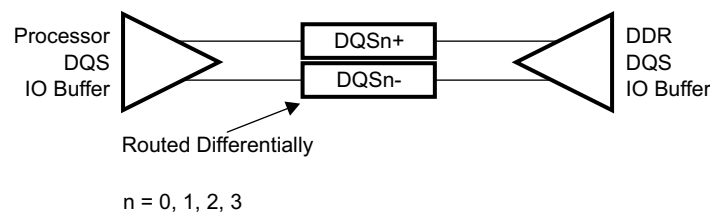

SPRS906\_PCB\_DDR3\_22

Figure 7-58. DQS Topology

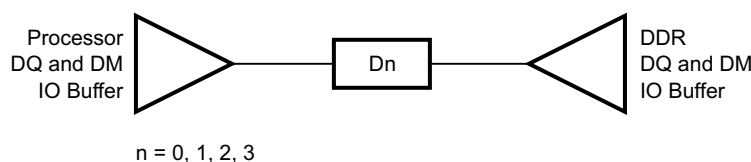

SPRS906\_PCB\_DDR3\_23

Figure 7-59. DQ/DM Topology

### 7.7.2.16.2 DQS and DQ/DM Routing, Any Number of Allowed DDR3 Devices

Figure 7-60 and Figure 7-61 show the DQS and DQ/DM routing.

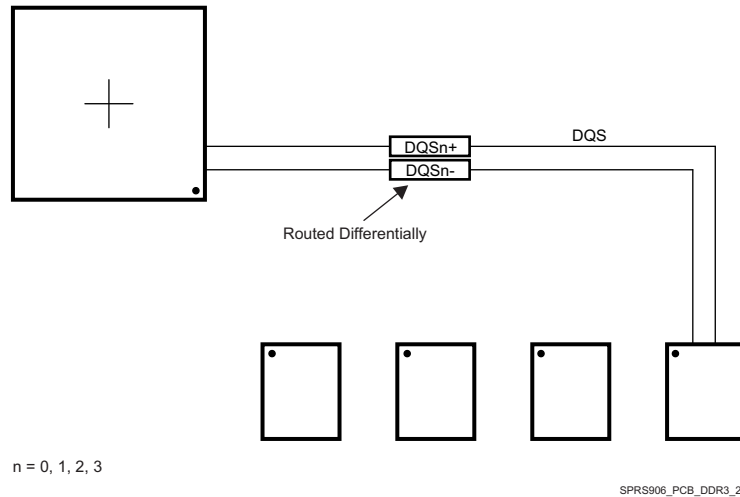

**Figure 7-60. DQS Routing With Any Number of Allowed DDR3 Devices**

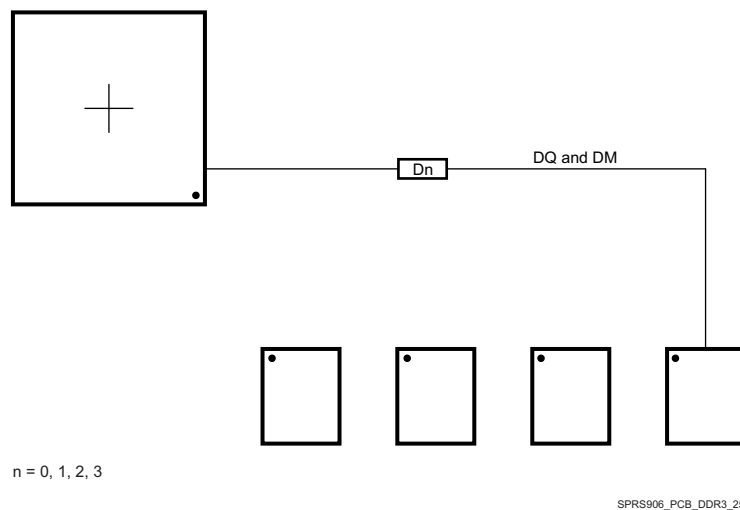

**Figure 7-61. DQ/DM Routing With Any Number of Allowed DDR3 Devices**

## 7.7.2.17 Routing Specification

### 7.7.2.17.1 CK and ADDR\_CTRL Routing Specification

Skew within the CK and ADDR\_CTRL net classes directly reduces setup and hold margin and, thus, this skew must be controlled. The only way to practically match lengths on a PCB is to lengthen the shorter traces up to the length of the longest net in the net class and its associated clock. A metric to establish this maximum length is Manhattan distance. The Manhattan distance between two points on a PCB is the length between the points when connecting them only with horizontal or vertical segments. A reasonable trace route length is to within a percentage of its Manhattan distance. CACLM is defined as Clock Address Control Longest Manhattan distance.

Given the clock and address pin locations on the processor and the DDR3 memories, the maximum possible Manhattan distance can be determined given the placement. Figure 7-62 and Figure 7-63 show this distance for four loads and two loads, respectively. It is from this distance that the specifications on the lengths of the transmission lines for the address bus are determined. CACLM is determined similarly for other address bus configurations; that is, it is based on the longest net of the CK/ADDR\_CTRL net class. For CK and ADDR\_CTRL routing, these specifications are contained in Table 7-34.

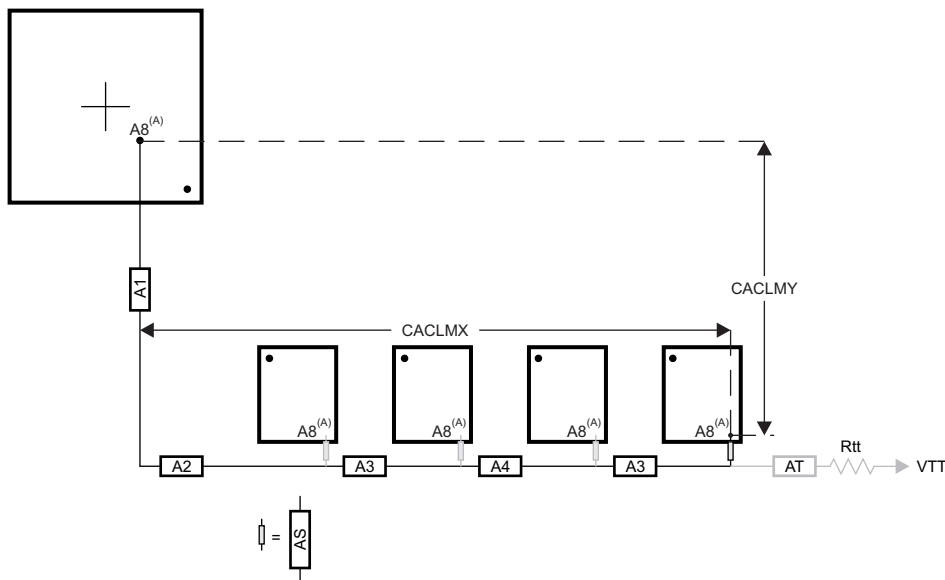

SPRS906\_PCB\_DDR3\_26

- A. It is very likely that the longest CK/ADDR\_CTRL Manhattan distance will be for Address Input 8 (A8) on the DDR3 memories. CACLM is based on the longest Manhattan distance due to the device placement. Verify the net class that satisfies this criteria and use as the baseline for CK/ADDR\_CTRL skew matching and length control.

The length of shorter CK/ADDR\_CTRL stubs as well as the length of the terminator stub are not included in this length calculation. Non-included lengths are grayed out in the figure.

Assuming A8 is the longest, CALM = CACLMY + CACLMX + 300 mils.

The extra 300 mils allows for routing down lower than the DDR3 memories and returning up to reach A8.

**Figure 7-62. CACLM for Four Address Loads on One Side of PCB**

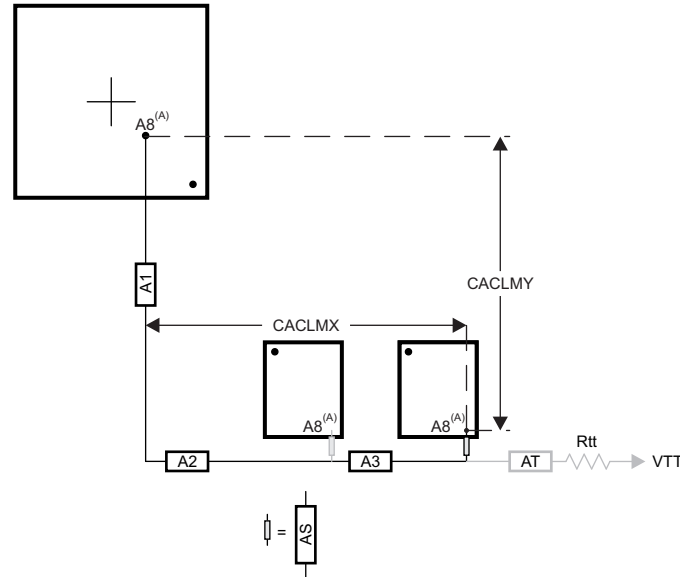

SPRS906\_PCB\_DDR3\_27

- A. It is very likely that the longest CK/ADDR\_CTRL Manhattan distance will be for Address Input 8 (A8) on the DDR3 memories. CACLM is based on the longest Manhattan distance due to the device placement. Verify the net class that satisfies this criteria and use as the baseline for CK/ADDR\_CTRL skew matching and length control.

The length of shorter CK/ADDR\_CTRL stubs as well as the length of the terminator stub are not included in this length calculation. Non-included lengths are grayed out in the figure.

Assuming A8 is the longest, CALM = CACLMY + CACLMX + 300 mils.

The extra 300 mils allows for routing down lower than the DDR3 memories and returning up to reach A8.

**Figure 7-63. CACLM for Two Address Loads on One Side of PCB**

**Table 7-34. CK and ADDR\_CTRL Routing Specification<sup>(2)(3)</sup>**

NO.	PARAMETER	MIN	TYP	MAX	UNIT
CARS31	A1+A2 length			500 <sup>(1)</sup>	ps
CARS32	A1+A2 skew			29	ps
CARS33	A3 length			125	ps
CARS34	A3 skew <sup>(4)</sup>			6	ps
CARS35	A3 skew <sup>(5)</sup>			6	ps
CARS36	A4 length			125	ps
CARS37	A4 skew			6	ps
CARS38	AS length		5	17 <sup>(1)</sup>	ps
CARS39	AS skew		1.3	14 <sup>(1)</sup>	ps
CARS310	AS+/AS- length		5	12	ps
CARS311	AS+/AS- skew			1	ps
CARS312	AT length <sup>(6)</sup>		75		ps
CARS313	AT skew <sup>(7)</sup>		14		ps
CARS314	AT skew <sup>(8)</sup>			1	ps
CARS315	CK/ADDR_CTRL trace length			1020	ps
CARS316	Vias per trace			3 <sup>(1)</sup>	vias
CARS317	Via count difference			1 <sup>(15)</sup>	vias
CARS318	Center-to-center CK to other DDR3 trace spacing <sup>(9)</sup>	4w			
CARS319	Center-to-center ADDR_CTRL to other DDR3 trace spacing <sup>(9)(10)</sup>	4w			
CARS320	Center-to-center ADDR_CTRL to other ADDR_CTRL trace spacing <sup>(9)</sup>	3w			

**Table 7-34. CK and ADDR\_CTRL Routing Specification<sup>(2)(3)</sup> (continued)**

NO.	PARAMETER	MIN	TYP	MAX	UNIT
CARS321	CK center-to-center spacing <sup>(11)(12)</sup>				
CARS322	CK spacing to other net <sup>(9)</sup>	4w			
CARS323	Rcp <sup>(13)</sup>	Zo-1	Zo	Zo+1	Ω
CARS324	Rtt <sup>(13)(14)</sup>	Zo-5	Zo	Zo+5	Ω

- (1) Max value is based upon conservative signal integrity approach. This value could be extended only if detailed signal integrity analysis of rise time and fall time confirms desired operation.
- (2) The use of vias should be minimized.
- (3) Additional bypass capacitors are required when using the DDR\_1V5 plane as the reference plane to allow the return current to jump between the DDR\_1V5 plane and the ground plane when the net class switches layers at a via.
- (4) Non-mirrored configuration (all DDR3 memories on same side of PCB).
- (5) Mirrored configuration (one DDR3 device on top of the board and one DDR3 device on the bottom).
- (6) While this length can be increased for convenience, its length should be minimized.
- (7) ADDR\_CTRL net class only (not CK net class). Minimizing this skew is recommended, but not required.
- (8) CK net class only.
- (9) Center-to-center spacing is allowed to fall to minimum 2w for up to 1250 mils of routed length.
- (10) The ADDR\_CTRL net class of the other DDR EMIF is considered *other DDR3 trace spacing*.
- (11) CK spacing set to ensure proper differential impedance.
- (12) The most important thing to do is control the impedance so inadvertent impedance mismatches are not created. Generally speaking, center-to-center spacing should be either 2w or slightly larger than 2w to achieve a differential impedance equal to twice the singleended impedance, Zo.
- (13) Source termination (series resistor at driver) is specifically not allowed.
- (14) Termination values should be uniform across the net class.
- (15) Via count difference may increase by 1 only if accurate 3-D modeling of the signal flight times – including accurately modeled signal propagation through vias – has been applied to ensure all segment skew maximums are not exceeded.

### 7.7.2.17.2 DQS and DQ Routing Specification

Skew within the DQS and DQ/DM net classes directly reduces setup and hold margin and thus this skew must be controlled. The only way to practically match lengths on a PCB is to lengthen the shorter traces up to the length of the longest net in the net class and its associated clock. As with CK and ADDR\_CTRL, a reasonable trace route length is to within a percentage of its Manhattan distance. DQLMn is defined as DQ Longest Manhattan distance n, where n is the byte number. For a 32-bit interface, there are four DQLMs, DQLM0-DQLM3. Likewise, for a 16-bit interface, there are two DQLMs, DQLM0-DQLM1.

#### NOTE

It is not required, nor is it recommended, to match the lengths across all bytes. Length matching is only required within each byte.

Given the DQS and DQ/DM pin locations on the processor and the DDR3 memories, the maximum possible Manhattan distance can be determined given the placement. [Figure 7-64](#) shows this distance for four loads. It is from this distance that the specifications on the lengths of the transmission lines for the data bus are determined. For DQS and DQ/DM routing, these specifications are contained in [Table 7-35](#).

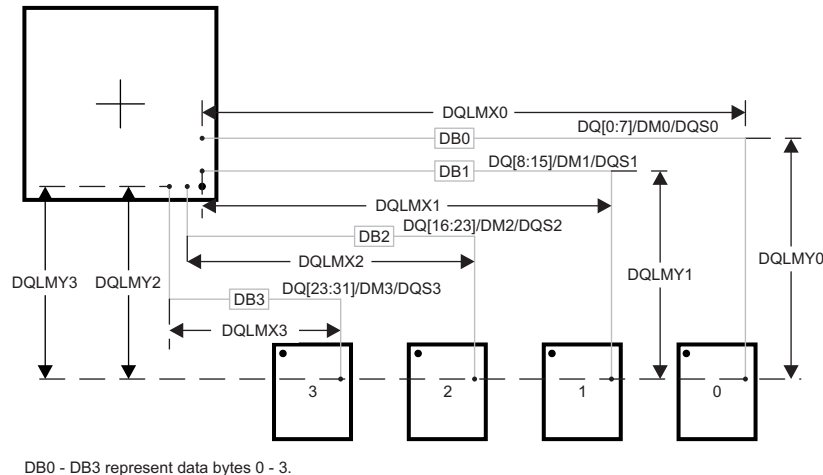

SPRS906\_PCB\_DDR3\_28

There are four DQLMs, one for each byte (32-bit interface). Each DQLM is the longest Manhattan distance of the byte; therefore:

$$DQLM0 = DQLMX0 + DQLMY0$$

$$DQLM1 = DQLMX1 + DQLMY1$$

$$DQLM2 = DQLMX2 + DQLMY2$$

$$DQLM3 = DQLMX3 + DQLMY3$$

**Figure 7-64. DQLM for Any Number of Allowed DDR3 Devices**

**Table 7-35. Data Routing Specification<sup>(2)</sup>**

NO.	PARAMETER	MIN	TYP	MAX	UNIT
DRS31	DB0 length			340	ps
DRS32	DB1 length			340	ps
DRS33	DB2 length			340	ps
DRS34	DB3 length			340	ps
DRS35	DBn skew <sup>(3)</sup>			5	ps
DRS36	DQSn+ to DQSn- skew			1	ps
DRS37	DQSn to DBn skew <sup>(3)(4)</sup>			5 <sup>(10)</sup>	ps
DRS38	Vias per trace			2 <sup>(1)</sup>	vias
DRS39	Via count difference			0 <sup>(10)</sup>	vias
DRS310	Center-to-center DBn to other DDR3 trace spacing <sup>(6)</sup>	4			w <sup>(5)</sup>
DRS311	Center-to-center DBn to other DBn trace spacing <sup>(7)</sup>	3			w <sup>(5)</sup>
DRS312	DQSn center-to-center spacing <sup>(8)(9)</sup>				
DRS313	DQSn center-to-center spacing to other net	4			w <sup>(5)</sup>

(1) Max value is based upon conservative signal integrity approach. This value could be extended only if detailed signal integrity analysis of rise time and fall time confirms desired operation.

(2) External termination disallowed. Data termination should use built-in ODT functionality.

(3) Length matching is only done within a byte. Length matching across bytes is neither required nor recommended.

(4) Each DQS pair is length matched to its associated byte.

(5) Center-to-center spacing is allowed to fall to minimum 2w for up to 1250 mils of routed length.

(6) Other DDR3 trace spacing means other DDR3 net classes not within the byte.

(7) This applies to spacing within the net classes of a byte.

(8) DQS pair spacing is set to ensure proper differential impedance.

(9) The most important thing to do is control the impedance so inadvertent impedance mismatches are not created. Generally speaking, center-to-center spacing should be either 2w or slightly larger than 2w to achieve a differential impedance equal to twice the single-ended impedance,  $Z_0$ .

(10) Via count difference may increase by 1 only if accurate 3-D modeling of the signal flight times – including accurately modeled signal propagation through vias – has been applied to ensure DBn skew and DQSn to DBn skew maximums are not exceeded.

## 8 Device and Documentation Support

TI offers an extensive line of development tools, including methods to evaluate the performance of the processors, generate code, develop algorithm implementations, and fully integrate and debug software and hardware modules as listed below.

### 8.1 Device Nomenclature

To designate the stages in the product development cycle, TI assigns prefixes to the part numbers of all microprocessors (MPUs) and support tools. Each device has one of three prefixes: X, P, or null (no prefix) (for example, TDA2Ex). Texas Instruments recommends two of three possible prefix designators for its support tools: TMDX and TMDS. These prefixes represent evolutionary stages of product development from engineering prototypes (TMDX) through fully qualified production devices and tools (TMDS).

Device development evolutionary flow:

- X** Experimental device that is not necessarily representative of the final device's electrical specifications and may not use production assembly flow.
- P** Prototype device that is not necessarily the final silicon die and may not necessarily meet final electrical specifications.
- null** Production version of the silicon die that is fully qualified.

Support tool development evolutionary flow:

- TMDX** Development-support product that has not yet completed Texas Instruments internal qualification testing.
- TMDS** Fully-qualified development-support product.

X and P devices and TMDX development-support tools are shipped against the following disclaimer:

"Developmental product is intended for internal evaluation purposes."

Production devices and TMDS development-support tools have been characterized fully, and the quality and reliability of the device have been demonstrated fully. TI's standard warranty applies.

Predictions show that prototype devices (X or P) have a greater failure rate than the standard production devices. Texas Instruments recommends that these devices not be used in any production system because their expected end-use failure rate still is undefined. Only qualified production devices are to be used.

For orderable part numbers of TDA2Ex devices in the CBD package type, see the Package Option Addendum of this document, the TI website ([ti.com](http://ti.com)), or contact your TI sales representative.

For additional description of the device nomenclature markings on the die, see the [TDA2Ex SoC for Advanced Driver Assistance Systems \(ADAS\) 23mm \(ABC\) Package \(SR2.0, SR1.0\) 17mm \(CBD\) Package \(SR2.1, SR2.0\)](#).

#### 8.1.1 Standard Package Symbolization

---

#### NOTE

Some devices may have a cosmetic circular marking visible on the top of the device package which results from the production test process. In addition, some devices may also show a color variation in the package substrate which results from the substrate manufacturer. These differences are cosmetic only with no reliability impact.

---

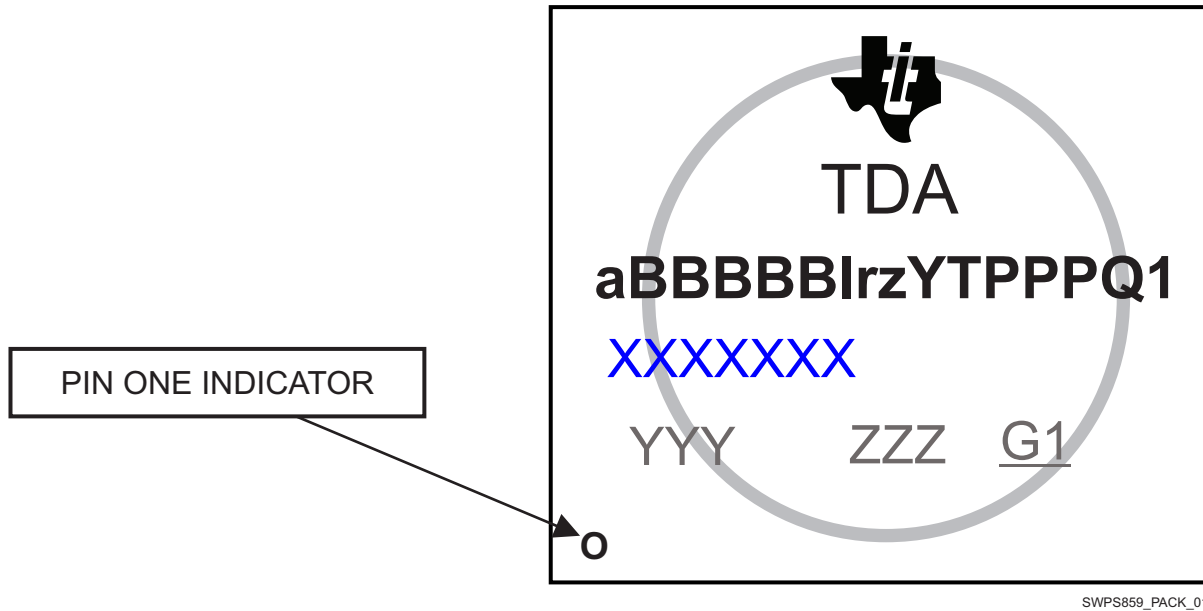

SWPS859\_PACK\_01

Figure 8-1. Printed Device Reference

### 8.1.2 Device Naming Convention

Table 8-1. Nomenclature Description

FIELD PARAMETER	FIELD DESCRIPTION	VALUES		DESCRIPTION
		SYMBOLIZATION	ORDERABLE	
a	Device evolution stage	X	Contact TI	Prototype
		P		Preproduction (production test flow, no reliability data)
		BLANK		Production
BBBBB <sup>(3)</sup>	Base production part number	TDA2E		ADAS 2 <sup>nd</sup> Generation Entry Tier
l	Device Identity	V		Scene Viewing
		G		GFX enabled
r	Device revision	BLANK		SR 1.0
		A		SR 2.0
		B		SR 2.1
z	Device Speed	D		Indicates the speed grade for each of the cores in the device. For more information see <a href="#">Table 3-1, Device Comparison</a> .
		H		
Y	Device type	BLANK		General purpose (Prototype and Production)
		E		Emulation (E) devices
		D		High security prototype devices with TI Development keys (D)
		S		High-Security device, Secure Boot Supported
T	Temperature	Q		Full temp range: -40°C to 125°C
PPP	Package designator	CBD		S-PBGA-N538 (17mm x 17mm) Package
c	Carrier designator	N/A	BLANK	Tray
		N/A	R	Tape & Reel
Q1	Automotive Designator	BLANK		Not meeting automotive qualification
		Q1		Meeting Q100 equal requirements, with exceptions as specified in DM.
XXXXXXX	Lot Trace Code	As marked	N/A	



**Table 8-1. Nomenclature Description (continued)**

FIELD PARAMETER	FIELD DESCRIPTION	VALUES		DESCRIPTION
		SYMBOLIZATION	ORDERABLE	
YYY	Production Code, For TI use only	<i>As marked</i>	N/A	
ZZZ	Production Code, For TI use onl	<i>As marked</i>	N/A	
O	Pin one designator	<i>As marked</i>	N/A	
G1	ECAT—Green package designator	<i>As marked</i>	N/A	

- (1) To designate the stages in the product development cycle, TI assigns prefixes to the part numbers. These prefixes represent evolutionary stages of product development from engineering prototypes through fully qualified production devices. Prototype devices are shipped against the following disclaimer:  
 "This product is still under development and is intended for internal evaluation purposes."  
 Notwithstanding any provision to the contrary, TI makes no warranty expressed, implied, or statutory, including any implied warranty of merchantability of fitness for a specific purpose, of this device.
- (2) Applies to device max junction temperature.
- (3) X777 base part number with X speed grade indicator is the part number for the superset device. Software should constrain the features and speed used to match the intended production device.

---

**NOTE**

BLANK in the symbol or part number is collapsed so there are no gaps between characters.

---

## 8.2 Tools and Software

The following products support development for TDA2Ex platforms:

### Design Kits and Evaluation Modules

#### TDA2EX17 Evaluation Module

The TDA2Ex-17 EVM is an evaluation platform designed to speed up development efforts and reduce time-to-market for ADAS applications. The EVM is based on the TDA2Eco SoC, which incorporates a heterogeneous, scalable architecture that includes a mix of TI's fixed and floating-point TMS320C66x digital signal processor (DSP) core, ARM Cortex-A15 MP core, 3D GPU core, H.264 encode/decode acceleration, and dual Cortex-M4 processor cores. The EVM also integrates a host of peripherals including multicamera interfaces (both parallel and serial) for LVDS-based surround view systems, displays, CAN, and GigB Ethernet AVB. The main board integrates these key peripherals such as Ethernet, FPD-Link and HDMI, while the Visionapplication board provides interfaces for popular imagers.

### Development tools

#### Clock Tree Tool for Sitara, Automotive, Vision Analytics, & Digital Signal Processors

The Clock Tree Tool (CTT) for Sitara™ Arm®, Automotive, and Digital Signal Processors is an interactive clock tree configuration software that provides information about the clocks and modules in these TI devices. It allows the user to: Visualize the device clock tree. Interact with clock tree elements and view the effect on PRCM registers. Interact with the PRCM registers and view the effect on the device clock tree. View a trace of all the device registers affected by the user interaction with clock tree.

#### XDS110 JTAG Debug Probe

The Texas Instruments XDS110 is a new class of debug probe (emulator) for TI embedded processors. The XDS110 replaces the XDS100 family while supporting a wider variety of standards (IEEE1149.1, IEEE1149.7, SWD) in a single pod. Also, all XDS debug probes support Core and System Trace in all Arm and DSP processors that feature an Embedded Trace Buffer (ETB).

The Texas Instruments XDS110 connects to the target board via a TI 20-pin connector (with multiple adapters for TI 14-pin and, Arm 10-pin and Arm 20-pin) and to the host PC via USB2.0 High Speed (480Mbps). It also features two additional connections: the Auxiliary 14-pin port connector that enables EnergyTrace™, a full duplex UART port and four General-Purpose I/Os, and the Expansion 30-pin connector to connect the XDS110 EnergyTrace HDR add-on.

## Models

[TDA2Ex-17 BSDL Model](#) BSDL Model

[TDA2Ex-17 IBIS Model](#) IBIS Model

[TDA2Ex-17 Thermal Model](#) Thermal Model

For a complete listing of development-support tools for the processor platform, visit the Texas Instruments website at [www.ti.com](http://www.ti.com). For information on pricing and availability, contact the nearest TI field sales office or authorized distributor.

## 8.3 Documentation Support

To receive notification of documentation updates, navigate to the device product folder on [ti.com](http://ti.com). In the upper right corner, click on *Alert me* to register and receive a weekly digest of any product information that has changed. For change details, review the revision history included in any revised document.

The following documents describe the TDA2Ex devices.

### Technical Reference Manual

[TDA2Ex SoC for Advanced Driver Assistance Systems \(ADAS\) 23mm \(ABC\) Package \(SR2.0, SR1.0\) 17mm \(CBD\) Package \(SR2.1, SR2.0\)](#)

Details the integration, the environment, the functional description, and the programming models for each peripheral and subsystem in the TDA3 family of devices.

### Errata

[TDA2Ex SoC for Advanced Driver Assistance Systems \(ADAS\) 23mm \(ABC\) Package \(SR2.0, SR1.0\) 17mm \(CBD\) Package \(SR2.1, SR2.0\)](#)

Describes the known exceptions to the functional specifications for the device.

## 8.4 Related Links

The table below lists quick access links. Categories include technical documents, support and community resources, tools and software, and quick access to sample or buy.

**Table 8-2. Related Links**

PARTS	PRODUCT FOLDER	SAMPLE & BUY	TECHNICAL DOCUMENTS	TOOLS & SOFTWARE	SUPPORT & COMMUNITY
TDA2EG-17	<a href="#">Click here</a>	<a href="#">Click here</a>	<a href="#">Click here</a>	<a href="#">Click here</a>	<a href="#">Click here</a>

## 8.5 Support Resources

[TI E2E™ support forums](#) are an engineer's go-to source for fast, verified answers and design help — straight from the experts. Search existing answers or ask your own question to get the quick design help you need.

Linked content is provided "AS IS" by the respective contributors. They do not constitute TI specifications and do not necessarily reflect TI's views; see TI's [Terms of Use](#).

## 8.6 Trademarks

E2E is a trademark of Texas Instruments.

OpenCL is a trademark of Apple, Inc.

Arm, Cortex, Thumb are registered trademarks of Arm Limited (or its subsidiaries) in the US and/or elsewhere.

HDMI is a trademark of HDMI Licensing, LLC.

PowerVR is a trademark of Imagination Technologies Limited.

JTAG is a registered trademark of JTAG Technologies, Inc.

Direct3D is a registered trademark of Microsoft Corporation in the United States and other countries.

MIPI is a registered trademark of Mobile Industry Processor Interface (MIPI) Alliance.

MMC, eMMC are trademarks of MultiMediaCard Association.

PCI Express is a registered trademark of PCI-SIG.  
SD is a registered trademark of Toshiba Corporation.  
Vivante is a registered trademark of Vivante Corporation.  
All other trademarks are the property of their respective owners.

## 8.7 Electrostatic Discharge Caution



This integrated circuit can be damaged by ESD. Texas Instruments recommends that all integrated circuits be handled with appropriate precautions. Failure to observe proper handling and installation procedures can cause damage.

ESD damage can range from subtle performance degradation to complete device failure. Precision integrated circuits may be more susceptible to damage because very small parametric changes could cause the device not to meet its published specifications.

## 8.8 Glossary

[TI Glossary](#) This glossary lists and explains terms, acronyms, and definitions.



## 9 Mechanical, Packaging, and Orderable Information

### 9.1 Packaging Information

The following pages include mechanical, packaging, and orderable information. This information is the most current data available for the designated devices. This data is subject to change without notice and revision of this document. For browser-based versions of this data sheet, refer to the left-hand navigation.

The device package has been specially engineered with a technology called Via Channel. The Via Channel Array technology allows larger than normal PCB via sizes, reduces the number of PCB signal layers required in a PCB design with this package, and will substantially reduce PCB costs compared to a full array 0.65mm pitch package.

**PACKAGING INFORMATION**

Orderable Device	Status (1)	Package Type	Package Drawing	Pins	Package Qty	Eco Plan (2)	Lead/Ball Finish (6)	MSL Peak Temp (3)	Op Temp (°C)	Device Marking (4/5)	Samples
TDA2EGBDQCBDQ1	ACTIVE	FCBGA	CBD	538	84	Green (RoHS & no Sb/Br)	SNAGCU	Level-3-260C-168 HR	-40 to 125	TDA2EGBDQCBDQ1 TDA 784 784 CBD G1	
TDA2EGBHQCBQ1	ACTIVE	FCBGA	CBD	538	84	Green (RoHS & no Sb/Br)	SNAGCU	Level-3-260C-168 HR	-40 to 125	TDA2EGBHQCBQ1 TDA 784 784 CBD G1	
TDA2EGBHQCBDRQ1	ACTIVE	FCBGA	CBD	538	750	Green (RoHS & no Sb/Br)	SNAGCU	Level-3-260C-168 HR	-40 to 125	TDA2EGBHQCBQ1 TDA 784 784 CBD G1	

(1) The marketing status values are defined as follows:

**ACTIVE:** Product device recommended for new designs.

**LIFEBUY:** TI has announced that the device will be discontinued, and a lifetime-buy period is in effect.

**NRND:** Not recommended for new designs. Device is in production to support existing customers, but TI does not recommend using this part in a new design.

**PREVIEW:** Device has been announced but is not in production. Samples may or may not be available.

**OBSELETE:** TI has discontinued the production of the device.

(2) **RoHS:** TI defines "RoHS" to mean semiconductor products that are compliant with the current EU RoHS requirements for all 10 RoHS substances, including the requirement that RoHS substance do not exceed 0.1% by weight in homogeneous materials. Where designed to be soldered at high temperatures, "RoHS" products are suitable for use in specified lead-free processes. TI may reference these types of products as "Pb-Free".

**RoHS Exempt:** TI defines "RoHS Exempt" to mean products that contain lead but are compliant with EU RoHS pursuant to a specific EU RoHS exemption.

**Green:** TI defines "Green" to mean the content of Chlorine (Cl) and Bromine (Br) based flame retardants meet JS709B low halogen requirements of <=1000ppm threshold. Antimony trioxide based flame retardants must also meet the <=1000ppm threshold requirement.

(3) MSL, Peak Temp. - The Moisture Sensitivity Level rating according to the JEDEC industry standard classifications, and peak solder temperature.

(4) There may be additional marking, which relates to the logo, the lot trace code information, or the environmental category on the device.

(5) Multiple Device Markings will be inside parentheses. Only one Device Marking contained in parentheses and separated by a "-" will appear on a device. If a line is indented then it is a continuation of the previous line and the two combined represent the entire Device Marking for that device.

(6) Lead/Ball Finish - Orderable Devices may have multiple material finish options. Finish options are separated by a vertical ruled line. Lead/Ball Finish values may wrap to two lines if the finish value exceeds the maximum column width.

**Important Information and Disclaimer:** The information provided on this page represents TI's knowledge and belief as of the date that it is provided. TI bases its knowledge and belief on information provided by third parties, and makes no representation or warranty as to the accuracy of such information. Efforts are underway to better integrate information from third parties. TI has taken and continues to take reasonable steps to provide representative and accurate information but may not have conducted destructive testing or chemical analysis on incoming materials and chemicals. TI and TI suppliers consider certain information to be proprietary, and thus CAS numbers and other limited information may not be available for release.

In no event shall TI's liability arising out of such information exceed the total purchase price of the TI part(s) at issue in this document sold by TI to Customer on an annual basis.

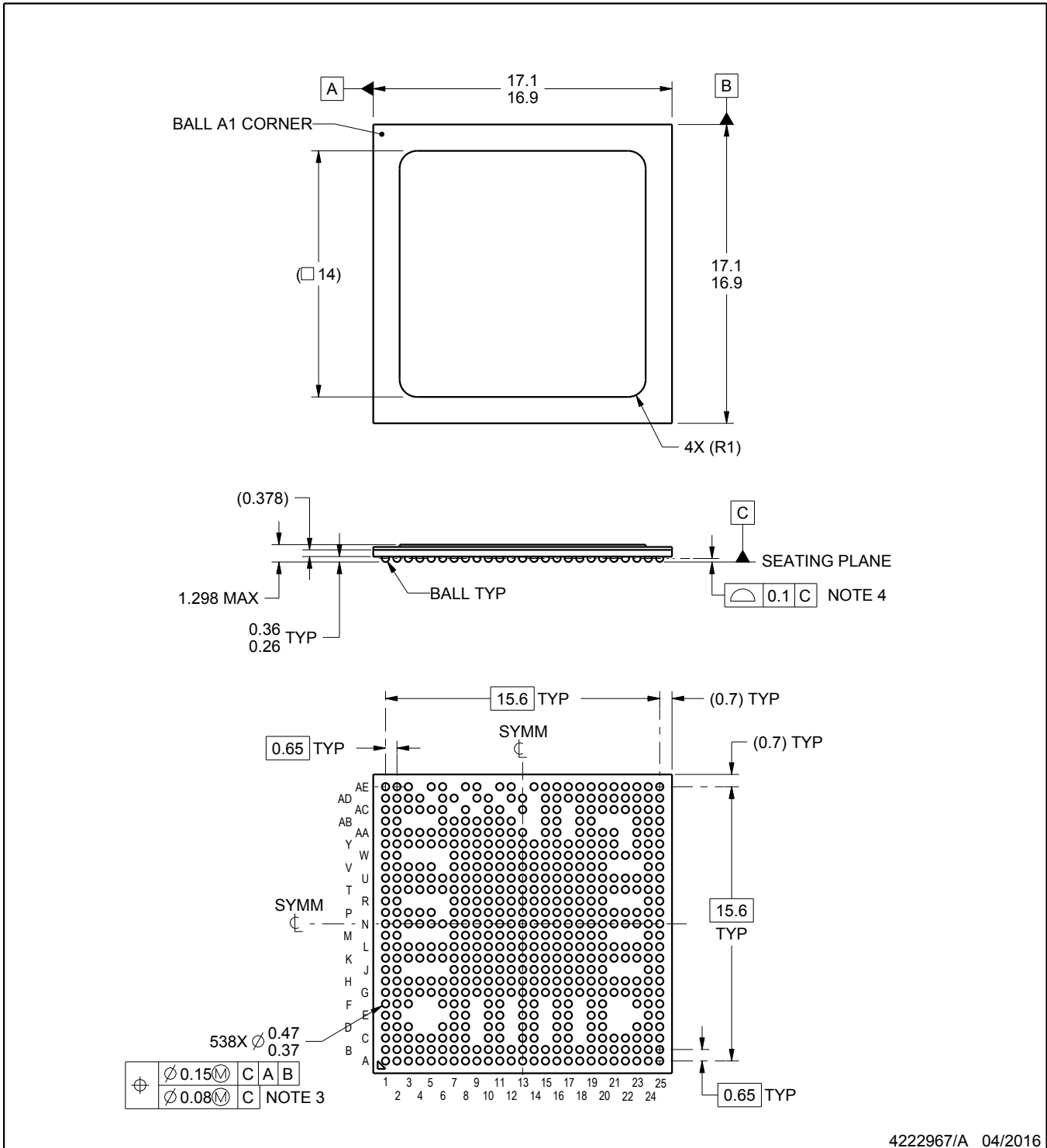
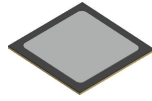

4222967/A 04/2016

NOTES:

1. All linear dimensions are in millimeters. Any dimensions in parenthesis are for reference only. Dimensioning and tolerancing per ASME Y14.5M.
2. This drawing is subject to change without notice.
3. Dimension is measured at the maximum solder ball diameter, parallel to primary datum C.
4. Primary datum C and seating plane are defined by the spherical crowns of the solder balls.

# EXAMPLE BOARD LAYOUT

**CBD0538A**

**FCBGA - 1.298 mm max height**

BALL GRID ARRAY

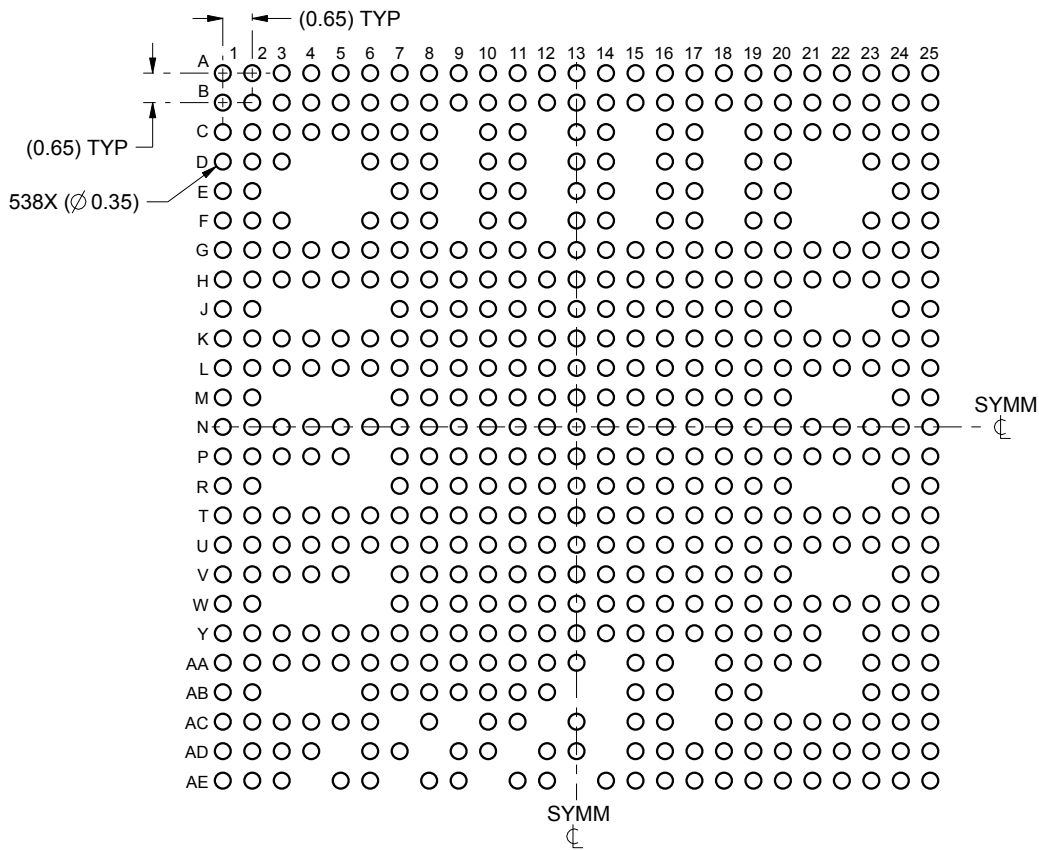

LAND PATTERN EXAMPLE  
SCALE:6X

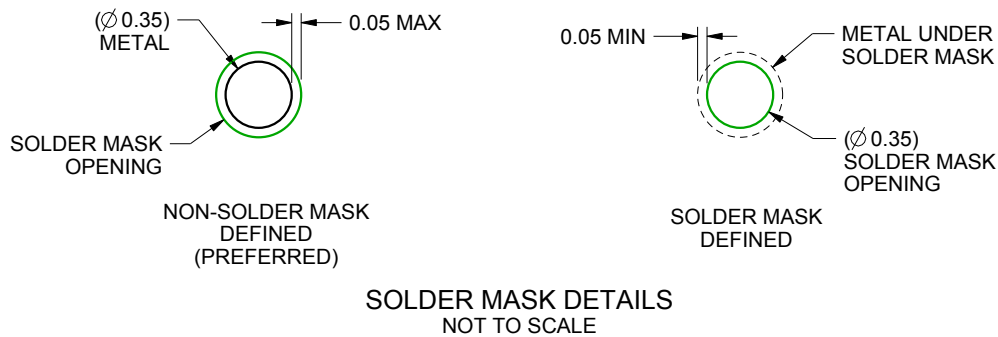

SOLDER MASK DETAILS  
NOT TO SCALE

4222967/A 04/2016

NOTES: (continued)

- Final dimensions may vary due to manufacturing tolerance considerations and also routing constraints. For more information, see Texas Instruments literature number SPRU811 ([www.ti.com/lit/spru811](http://www.ti.com/lit/spru811)).



# EXAMPLE STENCIL DESIGN

CBD0538A

FCBGA - 1.298 mm max height

BALL GRID ARRAY

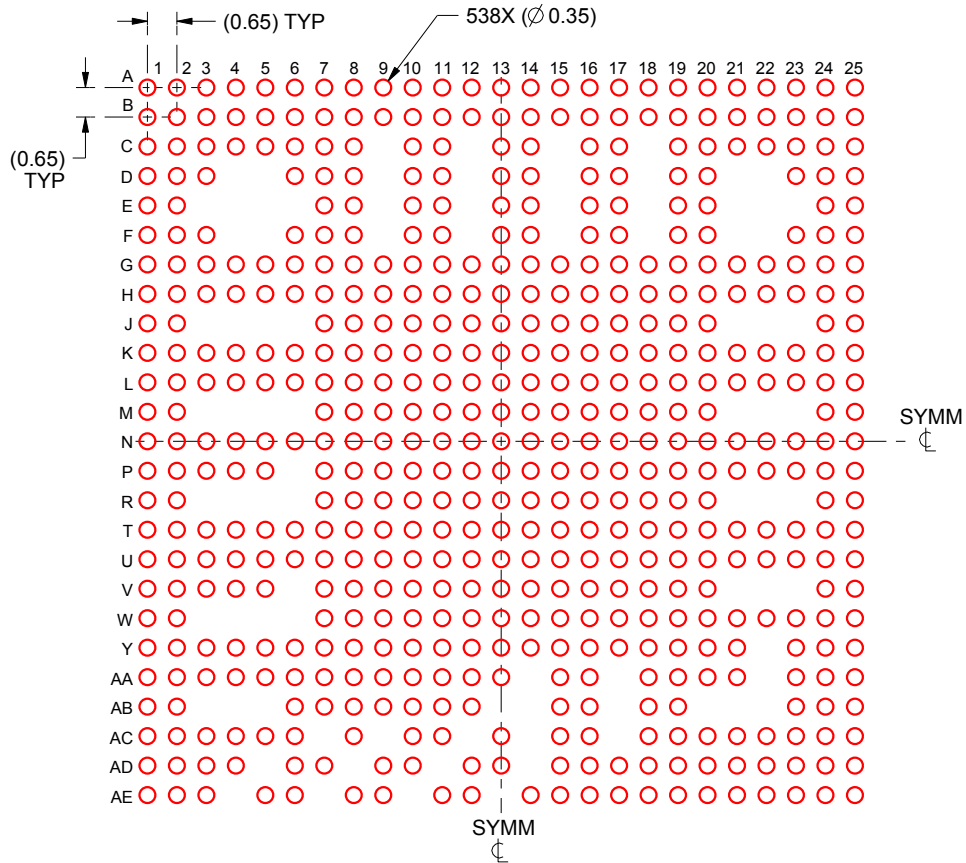

SOLDER PASTE EXAMPLE  
BASED ON 0.15 mm THICK STENCIL  
SCALE:6X

4222967/A 04/2016

NOTES: (continued)

6. Laser cutting apertures with trapezoidal walls and rounded corners may offer better paste release.

## IMPORTANT NOTICE AND DISCLAIMER

TI PROVIDES TECHNICAL AND RELIABILITY DATA (INCLUDING DATASHEETS), DESIGN RESOURCES (INCLUDING REFERENCE DESIGNS), APPLICATION OR OTHER DESIGN ADVICE, WEB TOOLS, SAFETY INFORMATION, AND OTHER RESOURCES "AS IS" AND WITH ALL FAULTS, AND DISCLAIMS ALL WARRANTIES, EXPRESS AND IMPLIED, INCLUDING WITHOUT LIMITATION ANY IMPLIED WARRANTIES OF MERCHANTABILITY, FITNESS FOR A PARTICULAR PURPOSE OR NON-INFRINGEMENT OF THIRD PARTY INTELLECTUAL PROPERTY RIGHTS.

These resources are intended for skilled developers designing with TI products. You are solely responsible for (1) selecting the appropriate TI products for your application, (2) designing, validating and testing your application, and (3) ensuring your application meets applicable standards, and any other safety, security, or other requirements. These resources are subject to change without notice. TI grants you permission to use these resources only for development of an application that uses the TI products described in the resource. Other reproduction and display of these resources is prohibited. No license is granted to any other TI intellectual property right or to any third party intellectual property right. TI disclaims responsibility for, and you will fully indemnify TI and its representatives against, any claims, damages, costs, losses, and liabilities arising out of your use of these resources.

TI's products are provided subject to TI's Terms of Sale ([www.ti.com/legal/termsofsale.html](http://www.ti.com/legal/termsofsale.html)) or other applicable terms available either on [ti.com](http://ti.com) or provided in conjunction with such TI products. TI's provision of these resources does not expand or otherwise alter TI's applicable warranties or warranty disclaimers for TI products.

Mailing Address: Texas Instruments, Post Office Box 655303, Dallas, Texas 75265  
Copyright © 2020, Texas Instruments Incorporated