

Multistandard Video-IF and Quasi Parallel Sound Processing**Description**

The TDA4471 is an integrated bipolar circuit for full multistandard video/sound IF (VIF/SIF) signal processing in TV/VCR and Multimedia applications. The circuit processes all TV video IF signals with negative modulation (e.g. B/G standard), positive modulation

(e.g. L standard) and the AM, FM/NICAM sound IF signals. Specially two video IF inputs (2 x VIF) in combination with one sound IF input (1 x SIF) and the common pinning with the TDA4474 gives flexibility to design a universal IF module for various applications.

Features

- 5V supply voltage; low power consumption
- Active carrier generation by FPLL principle (frequency-phase-locked-loop) for true synchronous demodulation
- Very linear video demodulation, good pulse response and excellent intermodulation figures
- VCO circuit is operating on picture carrier frequency, the VCO frequency is switchable for the L' mode
- Alignment-free AFC without external reference circuit, polarity of the AFC curve is switchable
- VIF-AGC for negative modulated signals (peak sync detection) and for positive modulation (peak white/black level detector)
- Tuner AGC with adjustable take over point
- Alignment-free quasi parallel sound (QPS) mixer for FM/NICAM sound IF signals
- Intercarrier output signal is gain controlled (necessary for digital sound processing)
- Complete alignment-free AM demodulator with gain controlled AF output
- Separate SIF-AGC with average detection
- Parallel operation of the AM demodulator and QPS mixer (for NICAM-L stereo sound)
- Two video IF inputs (2 x VIFin)
- One sound IF input (1 x SIFin)
- Package and relevant pinning is compatible with the TDA4474; simplifies the design of an universal IF module

Package:

30 pin shrink-dual-inline-plastic (SDIP30)

TDA4471

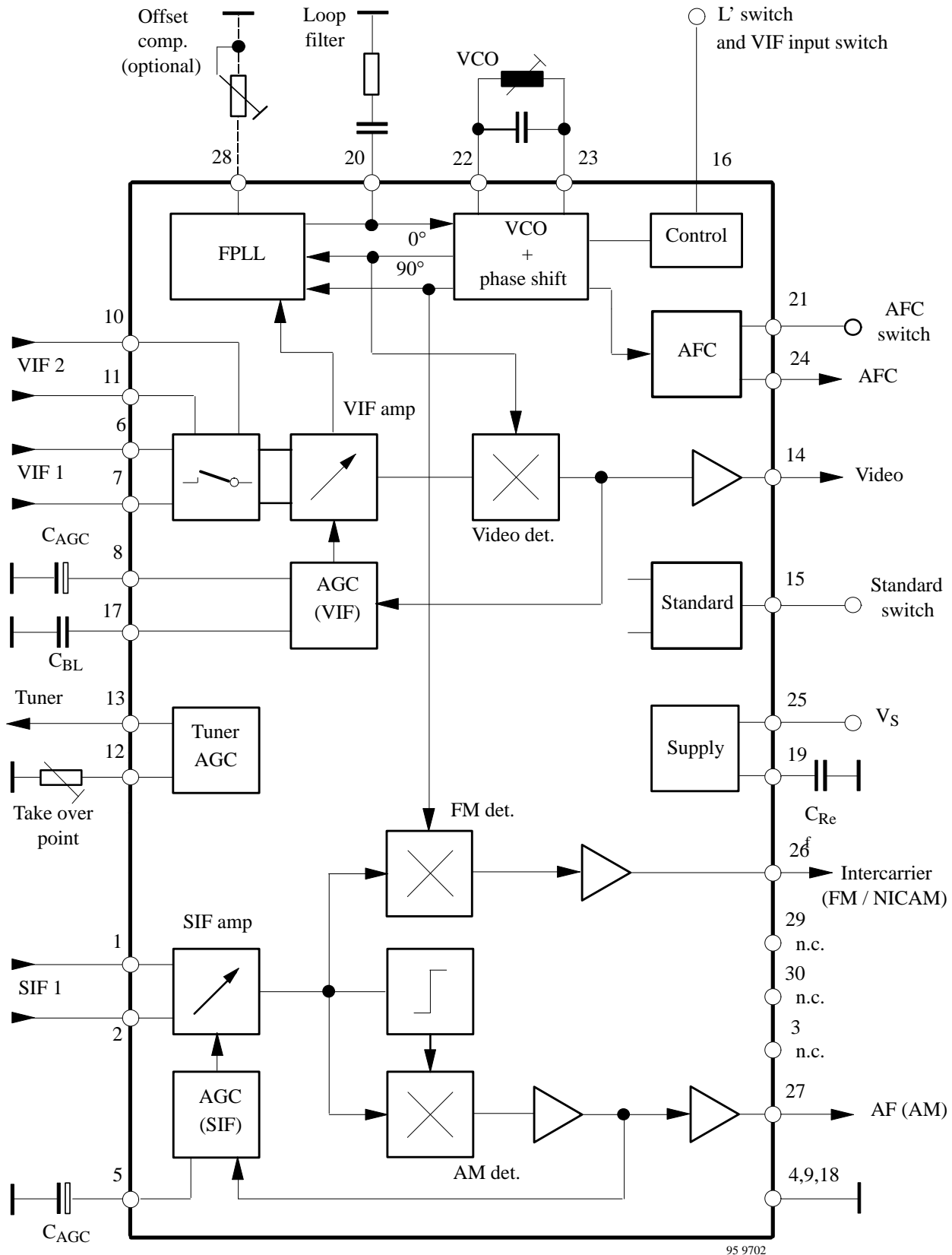

Figure 1. Block diagram

Pin Description

Pin	Symbol	Function
1, 2	$V_{i,SIF1}$	SIF1 input (symmetrical)
3	n.c.	not connected
4	GND	Ground
5	C_{AGC}	SIF-AGC (time constant)
6, 7	$V_{i,VIF1}$	VIF1 input (symmetrical)
8	C_{AGC}	VIF-AGC (time constant)
9	GND	Ground
10, 11	$V_{i,VIF2}$	VIF2 input (symmetrical)
12	R_{top}	Take over point, tuner AGC
13	I_{tun}	Tuner AGC output current
14	$V_{o,vid}$	Video output
15	V_{sw}	Standard switch
16	V_{sw}	L'-/VIF input selector switch
17	C_{bl}	Capacitor – black level detector
18	GND	Ground
19	C_{ref}	Internal reference voltage
20	LF	Loop filter
21	V_{sw}	AFC switch
22, 23	V_{vco}	VCO circuit
24	V_{AFC}	AFC output
25	V_s	Supply voltage
26	$V_{o,FM}$	Intercarrier output
27	$V_{o,AM}$	AF output – AM sound
28	R_{comp}	Offset compensation
29	n.c.	not connected
30	n.c.	not connected

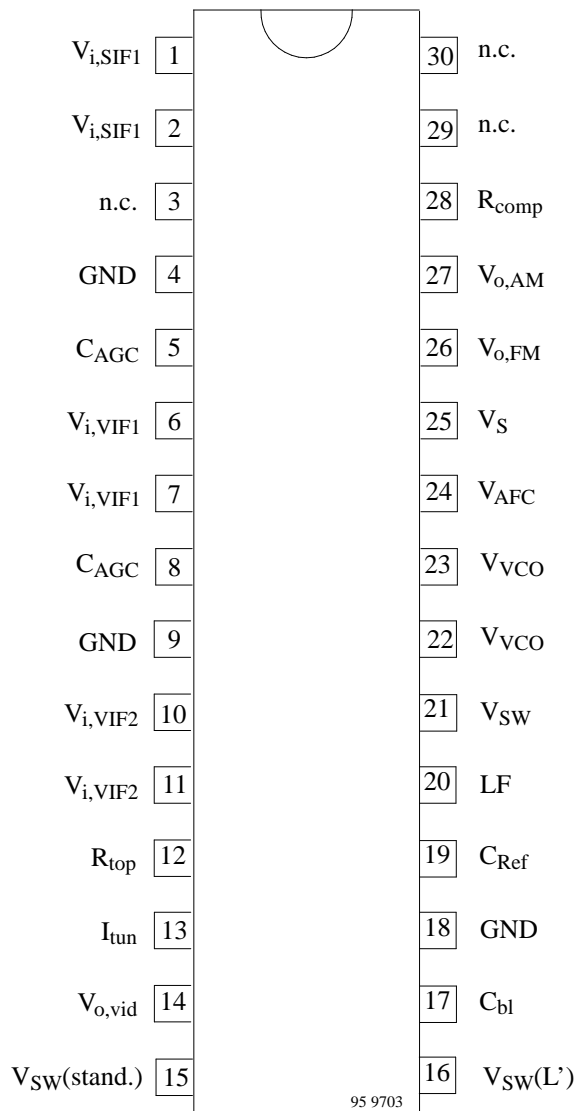

Figure 2. Pin configuration

TDA4471

Circuit Description

Vision IF amplifier

The video IF signal (VIF) is fed through a SAW filter to one of the two VIF inputs (Pins 6–7 or 10–11). The selection of VIF input is controlled by Pin 16 in combination with the standard switch. With a minimal external expense it is possible to switch between two different SAW filters. Both VIF inputs features excellent cross-talk attenuation and an input impedance which is independent from the switching condition. The VIF amplifier consists of three AC-coupled amplifier stages. Each differential amplifier is gain controlled by the automatic gain control (VIF-AGC). Output signal of the VIF amplifier is applied to the FPLL carrier generation and the video demodulator.

Tuner- and VIF-AGC

At Pin 8 the VIF-AGC charges/discharges the AGC capacitor to generate a control voltage for setting gain of VIF amplifier and tuner in order to keep the video output signal at a constant level. Therefore in case of negative modulated signals (e.g. B/G standard) the sync level of the demodulated video signal is the criterion for a fast charge/discharge of the AGC capacitor. For positive modulation (e.g. L standard) the peak white level of video signal controls the charge current. In order to reduce reaction time for positive modulation, where a very large time constant is needed, an additional black level detector (Pin 17) controls the discharge current in the event of decreasing VIF input signal. The AGC voltage is transferred to an internal control signal, and is fed to the tuner AGC to generate the tuner AGC current at Pin 13 (open collector output).

Take over point of the tuner AGC can be adjusted at Pin 12 by a potentiometer or an external DC voltage (from interface circuit or microprocessor).

FPLL, VCO and AFC

The FPLL circuit (frequency phase locked loop) consists of a frequency and phase detector to generate control voltage for the VCO tuning. In the locked mode the VCO is controlled by the phase detector and in unlocked mode the frequency detector is superimposed. The VCO operates with an external resonance circuit (L and C parallel) and is controlled by internal varicaps. The VCO control voltage is also converted to a current and represents the AFC output signal at Pin 24. With the AFC switch (Pin 21) three operating conditions of the AFC are possible: AFC curve "rising" or "falling" and AFC "off".

A practicable VCO alignment of the external coil is the adjustment to zero AFC output current at Pin 24. At centre

frequency the AFC output current is equal to zero. Furthermore, at Pin 16, the VCO centre frequency can be switched for setting to the required L' value. This function is active when "L mode" is selected by the standard switch.

The optional potentiometer at Pin 28 allows an offset compensation of the VCO phase for improved sound quality (fine adjustment). Without a potentiometer (open circuit at Pin 28) this offset compensation is not active.

The oscillator signal passes a phase shifter and supplies the in-phase signal (0) and the quadrature signal (90) of the generated picture carrier.

Video demodulation and amplifier

The video IF signal, which is applied from the gain controlled IF amplifier, is multiplied with the inphase component of the VCO signal. The video demodulator is designed for low distortion and large bandwidth. The demodulator output signal passes an integrated low pass filter for attenuation of the residual vision carrier and is fed to the video amplifier. The video amplifier is realized by an operational amplifier with internal feedback and 8 MHz bandwidth (-3dB). A standard dependent DC level shift in this stage delivers the same sync level for positive and negative modulation. An additional noise clipping is provided. The video signal is fed to VIF-AGC and to the video output buffer. This amplifier with 6dB gain offers easy adaption of the sound trap. For nominal video IF modulation the video output signal at Pin 14 is 2 V (peak to peak value).

Sound IF amplifier and SIF-AGC

The SIF amplifier is nearly identical with the 3-stage VIF amplifier. Each differential amplifier is gain controlled by the automatic gain control for the sound IF path (SIF-AGC). Output signal of the SIF amplifier is applied to the mixer for FM/NICAM signals and the limiter/demodulator for AM signals.

The SIF-AGC is related to the average level of AM- or FM-carrier and controls the SIF amplifier to provide a constant SIF signal to the AM demodulator and QPS mixer.

AM demodulator

The alignment-free AM demodulator is realized by a synchronous detector. The modulated SIF signal from the SIF amplifier output is multiplied in phase with the limited SIF signal (AM is removed). The AF signal of the demodulator output is fed to the output amplifier and to the SIF-AGC. For all TV standards with negative video

modulation (e.g. B/G standard) the AF output signal (Pin 27) is switched off by the standard switch.

Quasi-Parallel-Sound (QPS) mixer

The QPS mixer is realized by a multiplier. The SIF signal (FM or NICAM carrier) is converted to the intercarrier frequency by the regenerated picture carrier (quadrature signal) which is provided from the VCO. The intercarrier signal is fed via an output amplifier to Pin 26.

Standard switch

To have equal polarity of the video output signal the polarity can be switched in the demodulation stage in accordance with the TV standard. Additionally a standard dependent DC level shift in the video amplifier delivers the same sync level. Parallel the correct VIF-AGC is selected for positive or negative modulated VIF signals. In case of negative modulation (e.g. B/G standard) the AM output signal is switched off. If the standard for positive modulation (L standard) is selected the AM demodulator and QPS mixer is active. This condition allows a parallel operation of the AM sound signal and the NICAM-L stereo sound.

L' switch and VIF input selection

For positive modulated IF signals (L/L' standard) Pin 16 works as L' switch. With a control voltage at Pin 16 the VCO frequency can be switched for setting to the required L' value (L' standard). Also a fine adjustment of the L'-VCO centre frequency is possible by a potentiometer. The L' switch is only active for positive modulated video IF signals (standard switch in L mode). In this mode the video IF input 2 (VIF2) is forced by the standard switch. The possibility to select VIF1 input is given by connecting VIF2 input (pin 10 or 11) via 10 k resistor to ground.

If negative modulation (B/G mode) is selected pin 16 operates as an input selection switch for the two VIF inputs.

AFC switch

The AFC output signal at Pin 24 can be controlled by a switching voltage at Pin 21. It is possible to select an AFC output signal with rising- or falling AFC curve and to switch off the AFC.

Internal voltage stabilizer

The internal bandgap reference ensures constant performance independent of supply voltage and temperature.

Absolute maximum values

Reference point pin 4 (9, 18), unless otherwise specified

Parameters	Symbol	Value	Unit
Supply voltage Pin 25	V_S	9.0	V
Supply current Pin 25	I_S	85	mA
Power dissipation, $V_S = +9\text{ V}$	P	765	mW
Output currents Pin 14, 26, 27	I_{out}	5	mA
External voltages Pins 1, 2, 5-8, 10-12, 14, 16, 19, 20, 26-28 Pins 17, 22, 23 Pins 13 Pins 15, 21, 24	V_{ext}	+ 4.5	V
		+ 3.5	V
		+ 13.5	V
		V_S	V
Junction temperature	T_j	+125	°C
Storage temperature	T_{stg}	-25 to +125	°C
Electrostatic handling *) All pins	V_{ESD}	300	V

*) Equivalent to discharging a 200 pF capacitor through a 0 resistor

Operating Range

Parameters	Symbol	Value	Unit
Supply voltage range ²⁵	V_S	4.5 to 9.0	V
Ambient temperature	T_{amb}	0 to +85	°C

Thermal Resistance

Parameters	Symbol	Value	Unit
Thermal resistance: junction–ambient when soldered to PCB	R_{thJA}	55	K/W

Electrical Characteristics

$V_s = +5V$, $T_{amb} = +25^\circ C$; reference point Pin 4 (9, 18), unless otherwise specified

Parameters	Test Conditions / Pins	Symbol	Min.	Typ.	Max.	Unit
DC–supply Pin 25						
Supply voltage		V_S	4.5	5.0	9.0	V
Supply current:		I_S		75	85	mA
VIF–inputs Pin 6–7, 10–11						
Input sensitivity, RMS value	for FPLL locked	v_{in}		80	120	μV
Input impedance	see note 1	R_{in}		1.2		k
Input capacitance	see note 1	C_{in}		2		pF
VIF–AGC Pin 8, 17						
IF gain control range		G_v	60	65		dB
AGC capacitor at pin 8		C_{AGC}		2.2		μF
Black level capacitor at pin 17		C_{BL}		100		nF
Tuner–AGC Pin 12, 13 see note 2						
Available tuner–AGC current		I_{tun}	1	2	4	mA
Allowable output voltage		V_{out}	0.3		13.5	V
IF slip – tuner AGC	current I_{tun} : 10% to 90%	G_{IF}		8	10	dB
IF input signal for minimum take over point	$R_{top} = 10\text{ k}$ ($V_{top} = 4.5\text{ V}$)	v_{in}			4	mV
IF input signal for maximum take over point	$R_{top} = 0$ ($V_{top} = 0.8\text{ V}$)	v_{in}	40			mV
Variation of the take over point by temperature	$T_{amb} = 55^\circ C$ VIF–AGC: $G_v = 46\text{ dB}$	v_{in}		2	3	dB
FPLL and VCO Pin 20, 22, 23, 28						
Max. oscillator frequency	for carrier generation	f_{vco}	70			MHz
Vision carrier capture range	$f_{vco} = 38.9\text{ MHz}$ $C_{vco} = 6.8\text{ pF}$	f_{cap}	1.5	2		MHz
Oscillator drift (free running) as function of temperature	see note 3 $T_{amb} = 55^\circ C$, $C_{vco} = 6.8\text{ pF}$, $f_{vco} = 38.9\text{ MHz}$	f/T			–0.3	%

Electrical Characteristics

$V_s = +5V$, $T_{amb} = +25^\circ C$; reference point Pin 4 (9, 16), unless otherwise specified

Parameters	Test Conditions / Pins	Symbol	Min.	Typ.	Max.	Unit
Video output						
Pin 14						
Output current – source – sink		I_{out}	2		5 3	mA mA
Output resistance	see note 1	R_{out}			100	
Video output signal	peak to peak value	$v_{o,vid}$	1.8	2.0	2.2	V
Difference of the video signals	between B/G and L	$v_{o,vid}$			10	%
Sync level		V_{sync}		1.2		V
Zero carrier level for neg. modulation (Ultra white level)	$V_8 = 3 V$	V_{DC}		3.4		V
Zero carrier level for pos. modulation (Ultra black level)	$V_8 = 3 V$	V_{DC}		1.15		V
Supply voltage influence on the ultra black– and ultra white level		V/V		1		%/V
Video bandwidth (–3dB)	$R_L 1 k, C_L 50 pF$	B	6	8		MHz
Video frequency response over the AGC range		B			2.0	dB
Differential gain error		DG		2	5	%
Differential phase error		DP		2	5	deg
Intermodulation 1.07MHz	see note 4	IM	52	60		dB
Video signal to noise ratio	weighted , CCIR–567	S/N	56	60		dB
Residual vision carrier fundamental wave 38.9 MHz and second harmonic 77.8 MHz		v_{res1}		2	10	mV
Lower limiting level	below sync level	V_{lim1}		400		mV
Upper limiting level	above ultra white level	V_{lim2}		600		mV
Ripple rejection	Pins 25, 14 see note 1	RR	35			dB

TDA4471

Electrical Characteristics

$V_s = +5V$, $T_{amb} = +25^\circ C$; reference point Pin 4 (9,16), unless otherwise specified

Parameters	Test Conditions / Pins	Symbol	Min.	Typ.	Max.	Unit
Standard switch						
Pin 15						
Control voltage for mode 1: neg. modulated video-IF signals and FM/NICAM sound	see note 5 note 2	V_{SW1}	2.0		V_s	V
Control voltage for mode 2: pos. modulated video-IF signals and AM / L-NICAM sound		V_{SW2}	0		0.8	V
Switching current		I_{SW}		100		A
AFC output						
Pin 24						
Control slope		I/f		0.7		A/kHz
Frequency drift by temperature	related to the picture carrier frequency			0.25	0.6	%
Output voltage upper limit lower limit		V_{AFC}	$V_s - 0.4$		0.4	V V
Output current		I_{AFC}		0.2		mA
AFC switch						
Pin 21						
Control voltage: AFC "off" AFC curve rising AFC curve falling	see note 6	V_{SW}	0 1.5 3.5		0.8 2.5 V_s	V
Switching current		I_{SW}		100		A
L'/VIF input selector switch						
Pin 16 see note 7						
Control voltage: L'-VCO frequency L'-VCO frequency	standard switch in mode 2 (L standard)	V_{SW2}	0 3.4		3.0 4.5	V
Control voltage: VIF input 2 active VIF input 1 active	standard switch in mode 1 (B/G standard)	V_{SW1}	0 3.4		3.0 4.5	V
Switching current	$V_{SW} = 0$	I_{SW}			700	A

Electrical Characteristics

$V_s = +5V$, $T_{amb} = +25^\circ C$; reference point Pin 4 (9, 18), unless otherwise specified

Parameters	Test Conditions / Pins	Symbol	Min.	Typ.	Max.	Unit
SIF input Pin 1–2						
Input sensitivity, RMS value	output signal: –3dB	v_{in}		80	120	V
Input impedance	see note 1	R_{in}		1.2		k
Input capacitance	see note 1	C_{in}		2		pF
SIF – AGC: (pin 5)						
IF gain control range		G_V	60	65		dB
AGC capacitor		C_{AGC}		10		F
Intercarrier output– FM Pin 26 see note 8						
DC output voltage		V_{DC}		2		V
Output resistance	see note 1	R_{out}		150		
Sound IF output voltage, RMS value	5.5 MHz output voltage $v_{in} = 10$ mV	v_{out}		300		mV
Weighted signal to noise ratio: (CCIR 468)	Ref. signal: $v_{in} = 10$ mV; FM dev. = 27 kHz $f_{mod} = 1$ kHz; tested with the double FM demod. U2860B; B/G modulated IF signal					
		S/N		60/58		dB
Black screen: Channel 1/2		S/N		54/52		dB
Grid pattern: Channel 1/2		S/N		60/57		dB
Grey screen 50%: Channel 1/2						
Ripple rejection	Pins 25, 26 see note 1	RR	35			dB

Electrical Characteristics

$V_s = +5V$, $T_{amb} = +25^\circ C$; reference point Pin 4 (9, 16), unless otherwise specified

Parameters	Test Conditions / Pins	Symbol	Min.	Typ.	Max.	Unit
AF output – AM Pin 27 see note 9						
DC output voltage		V_{DC}		2.2		V
Output resistance	see note 1	R_{out}		150		
AF output voltage, RMS value	$m = 54$ %	v_{oAF}		500		mV
Total harmonic distortion	$m = 54$ % $f_{mod} = 1$ kHz, 12.5 kHz	THD		1	2	%
Signal to noise ratio	Reference: $m = 54$ %, $f_{mod} = 1$ kHz, 22 kHz low pass filter	S/N		65		dB
Ripple rejection	Pin 25, 27 see note 1	RR	28			dB

Notes:

- This parameter is given as an application information and not tested during production.
- Adjustment of turn over point (delayed tuner AGC) with external resistor R_{top} or external voltage V_{top} .
- The oscillator drift is related to picture carrier frequency, at external temperature-compensated LC circuit
- $(1.07) = 20 \log (4.43 \text{ MHz component}/1.07 \text{ MHz component})$;
(1.07) value related to black-white signal
input signal conditions: picture carrier 0 dB
colour carrier -6 dB
sound carrier -24 dB
- Without external control voltage at Pin 15 (open circuit) the IC automatically operates in mode :
negative modulated video IF and FM/NICAM sound signals

Voltage at Pin 15 (standard switch)	0 – 0.8 V	2.0V – V_s (or Pin 15 open)
Selected standard (mode)	mode 2 (L standard) VIF: pos. modulation SIF: AM + NICAM	mode 1 (B/G standard) VIF: neg. modulation SIF: FM/ NICAM

- Without control voltage at Pin 21 (open circuit) the falling AFC curve is automatically selected

Voltage at Pin 21 (AFC switch)	0 – 0.8 V	1.5 – 2.5 V	3.5 V – V_s (or Pin 21 open)
AFC function	AFC switched OFF	AFC curve rising	AFC curve falling

- Without control voltage at Pin 16 (open circuit) the L' switch is not active.

St Package (Dimensions in mm) stan- dard switch, Pin 15	Mode 1: neg. modulation (B/G) 2.0 V – V_S				Mode 2: pos. modulation (L) 0 – 0.8 V			
L'/VIF input switch, Pin 16	3.4 V – 4.5 V (or Pin 16 open)		0 – 3.1 V		3.4 V – 4.5 V (or Pin 16 open)		0 – 3.1 V	
Ext. voltage at VIF input 2, Pin 10 or 11	open	1 V	open	1 V	open	1 V	open	1 V
Modulation	neg.	neg.	neg.	*)	neg.	neg.	neg.	neg.
Standard	B/G,...	B/G,...	B/G,...	*)	L	L	L'	L'
Active VIF input	VIF1	VIF1	VIF2	*)	VIF2	VIF1	VIF2	VIF1

*) condition not useful

- Picture carrier $PC = 38.9 \text{ MHz}$; sound carrier $SC_1 = 33.4 \text{ MHz}$, $SC_2 = 33.16 \text{ MHz}$;
 $PC/SC_1 = 13 \text{ dB}$; $PC/SC_2 = 20 \text{ dB}$; PC unmodulated (equivalent to sync peak level)
- Sound carrier $SC = 32.4 \text{ MHz}$, modulated with $f_{mod} = 1 \text{ kHz}$, $m = 54 \%$; $v_{in} = 10 \text{ mV}$

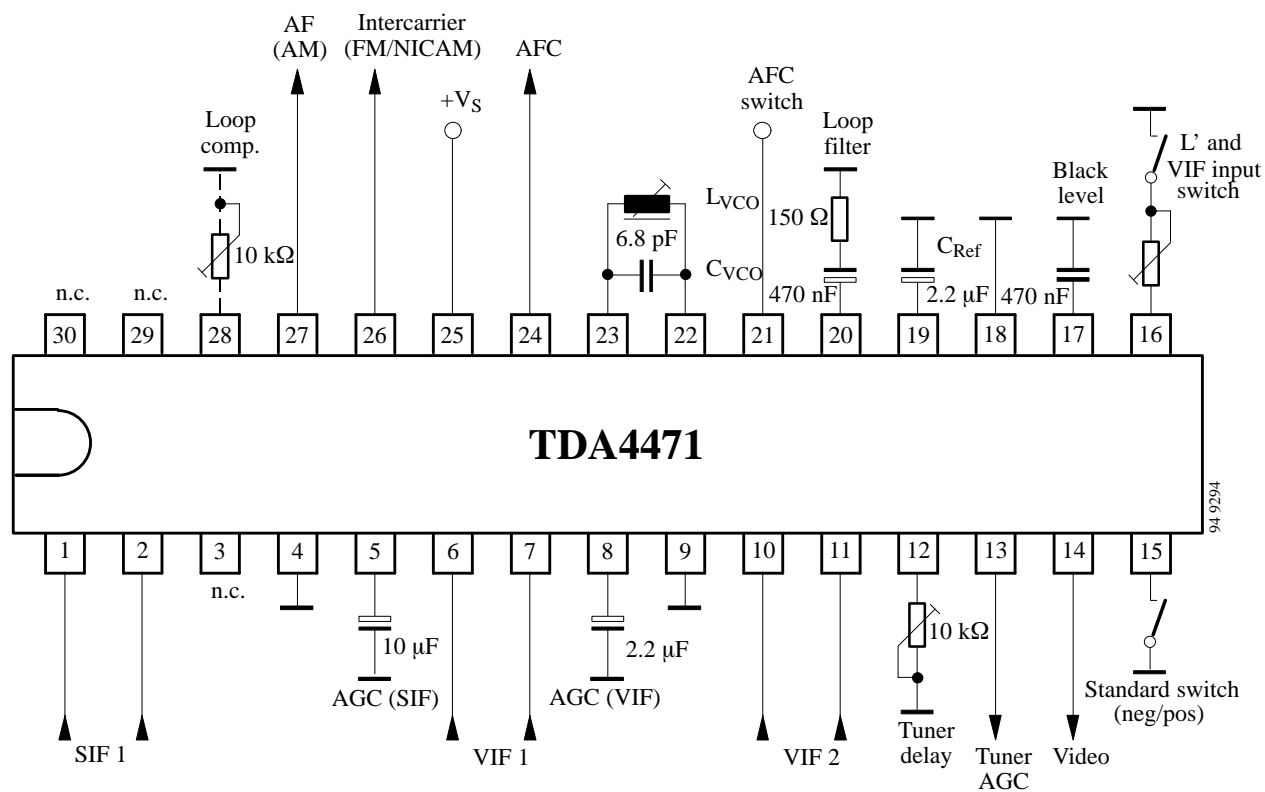

*) External L/C circuit (VCO: 38.9 MHz) with TOKO coil 7KN (9 turns, 0.12mm)

Figure 3. Test circuit

TDA4471

TEMIC

TELEFUNKEN Semiconductors

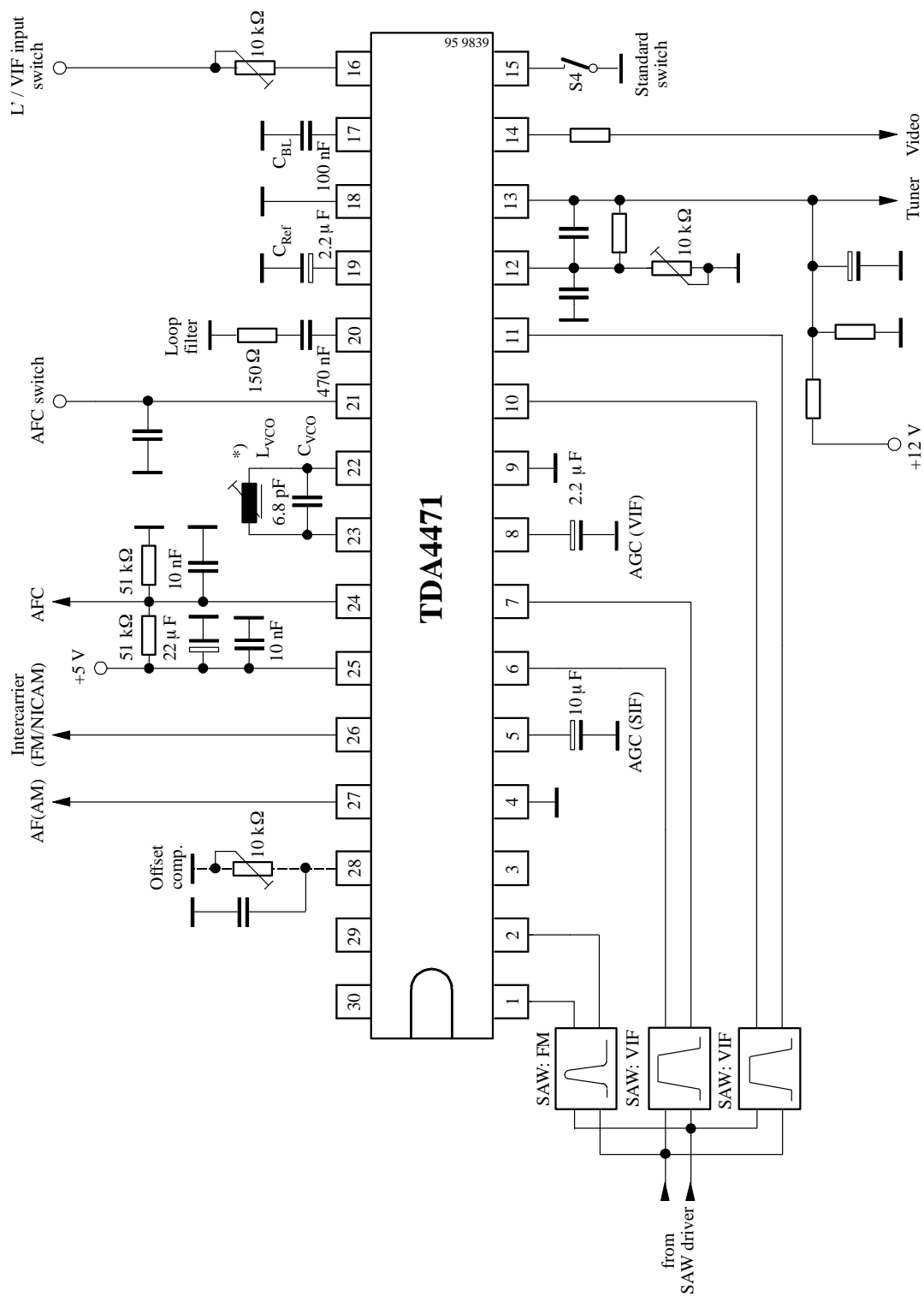

Figure 4. Basic application circuit

Internal Pin Configuration

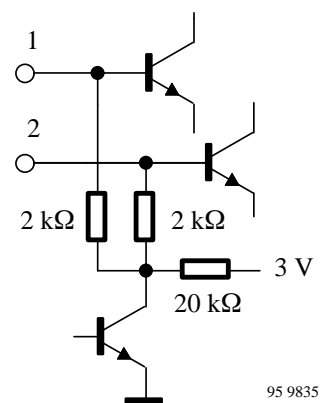

Figure 5. Sound IF inputs (Pin 1-2)

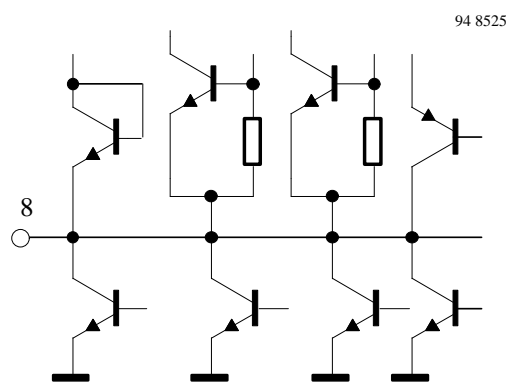

Figure 8. VIF-AGC time constant (Pin 8)

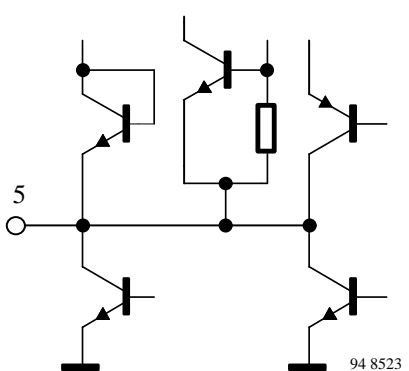

Figure 6. SIF-AGC time constant (Pin 5)

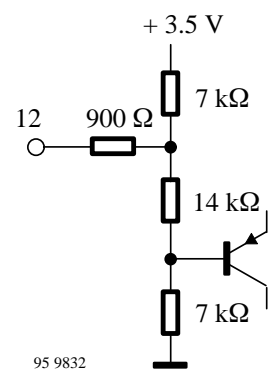

Figure 9. Tuner AGC - take over point (Pin 12)

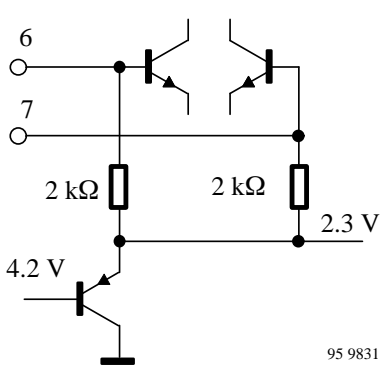

Figure 7. Video IF input (Pin 6-7)

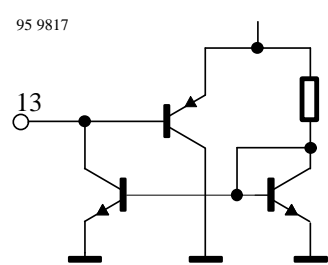

Figure 10. Tuner AGC - output (Pin 13)

TDA4471

TEMIC

TELEFUNKEN Semiconductors

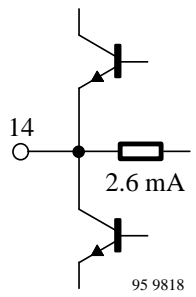

Figure 11. Video output (Pin 14)

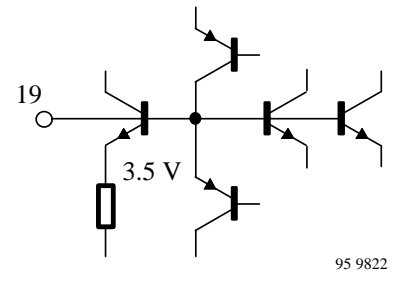

Figure 15. Internal reference voltage (Pin 19)

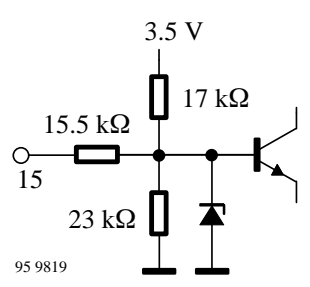

Figure 12. Standard switch (Pin 15)

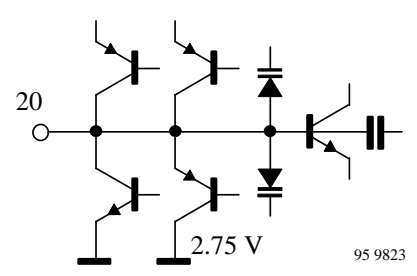

Figure 16. Loop filter (Pin 20)

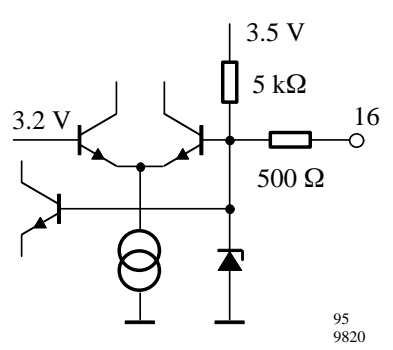

Figure 13. L'/VIF input switch (Pin 16)

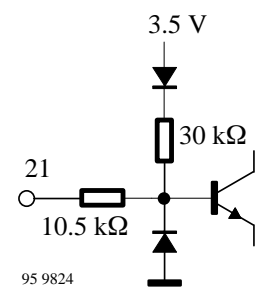

Figure 17. AFC switch (Pin 21)

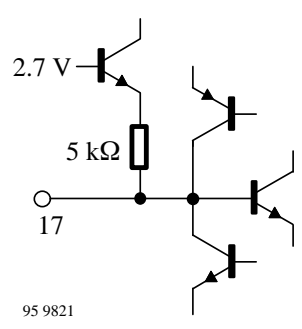

Figure 14. Black level capacitor (Pin 17)

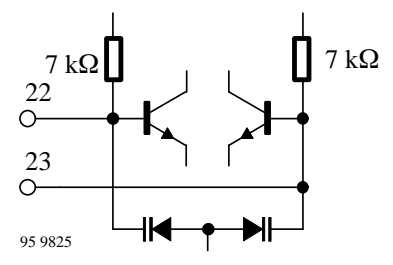

Figure 18. VCO (Pin 22-23)

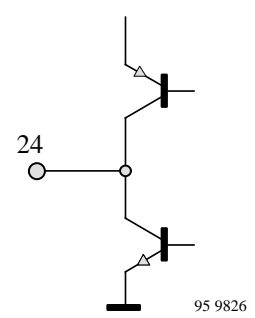

Figure 19. AFC output (Pin 24)

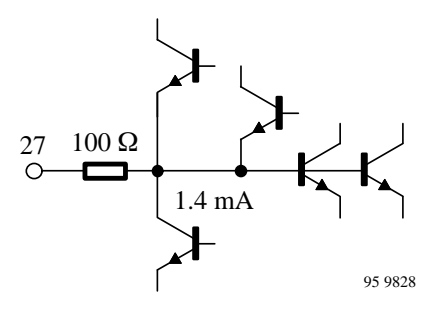

Figure 21. AF-AM output (Pin 27)

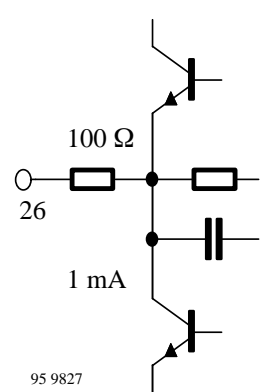

Figure 20. Intercarrier output (Pin 26)

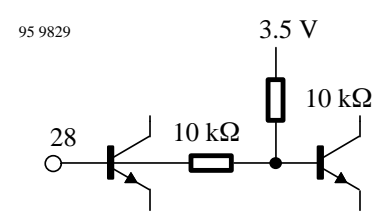
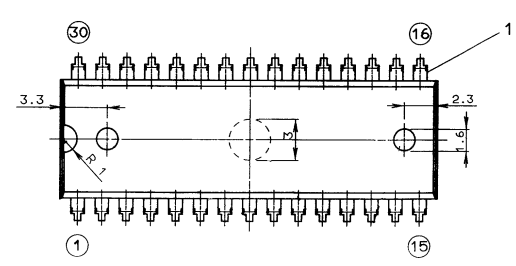
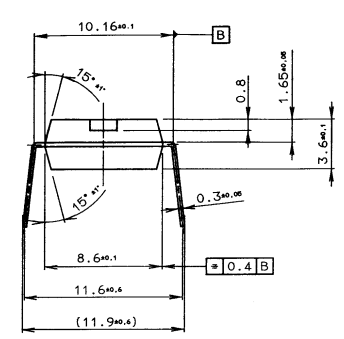
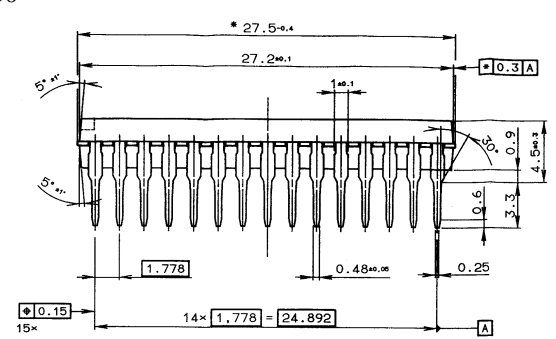

Figure 22. VCO offset compensation (Pin 28)

Dimensions in mm

Package: SDIP30



TDA4471

Ozone Depleting Substances Policy Statement

It is the policy of **TEMIC TELEFUNKEN microelectronic GmbH** to

1. Meet all present and future national and international statutory requirements.
2. Regularly and continuously improve the performance of our products, processes, distribution and operating systems with respect to their impact on the health and safety of our employees and the public, as well as their impact on the environment.

It is particular concern to control or eliminate releases of those substances into the atmosphere which are known as ozone depleting substances (ODSs).

The Montreal Protocol (1987) and its London Amendments (1990) intend to severely restrict the use of ODSs and forbid their use within the next ten years. Various national and international initiatives are pressing for an earlier ban on these substances.

TEMIC TELEFUNKEN microelectronic GmbH semiconductor division has been able to use its policy of continuous improvements to eliminate the use of ODSs listed in the following documents.

1. Annex A, B and list of transitional substances of the Montreal Protocol and the London Amendments respectively
2. Class I and II ozone depleting substances in the Clean Air Act Amendments of 1990 by the Environmental Protection Agency (EPA) in the USA
3. Council Decision 88/540/EEC and 91/690/EEC Annex A, B and C (transitional substances) respectively.

TEMIC can certify that our semiconductors are not manufactured with ozone depleting substances and do not contain such substances.

We reserve the right to make changes to improve technical design and may do so without further notice.

Parameters can vary in different applications. All operating parameters must be validated for each customer application by the customer. Should the buyer use TEMIC products for any unintended or unauthorized application, the buyer shall indemnify TEMIC against all claims, costs, damages, and expenses, arising out of, directly or indirectly, any claim of personal damage, injury or death associated with such unintended or unauthorized use.

TEMIC TELEFUNKEN microelectronic GmbH, P.O.B. 3535, D-74025 Heilbronn, Germany
Telephone: 49 (0)7131 67 2831, Fax number: 49 (0)7131 67 2423