

Multistandard quasi parallel-sound processor for Mono-TV-Sets

Technology: Bipolar

Features

- High signal sensitivity
- High signal to noise ratio
- Easy alignment of the multistandard filters
- Converter for different intercarrier frequencies
- AF output level matched to SIMAVELEC condition
- Few external components
- Alignment free AM demodulator for standard L
- Standardized SCART interface
- Standard-, SCART- and Mute-switch TTL compatible
- AF attenuator
- ESD protected

Case: 20-pin dual inline plastic

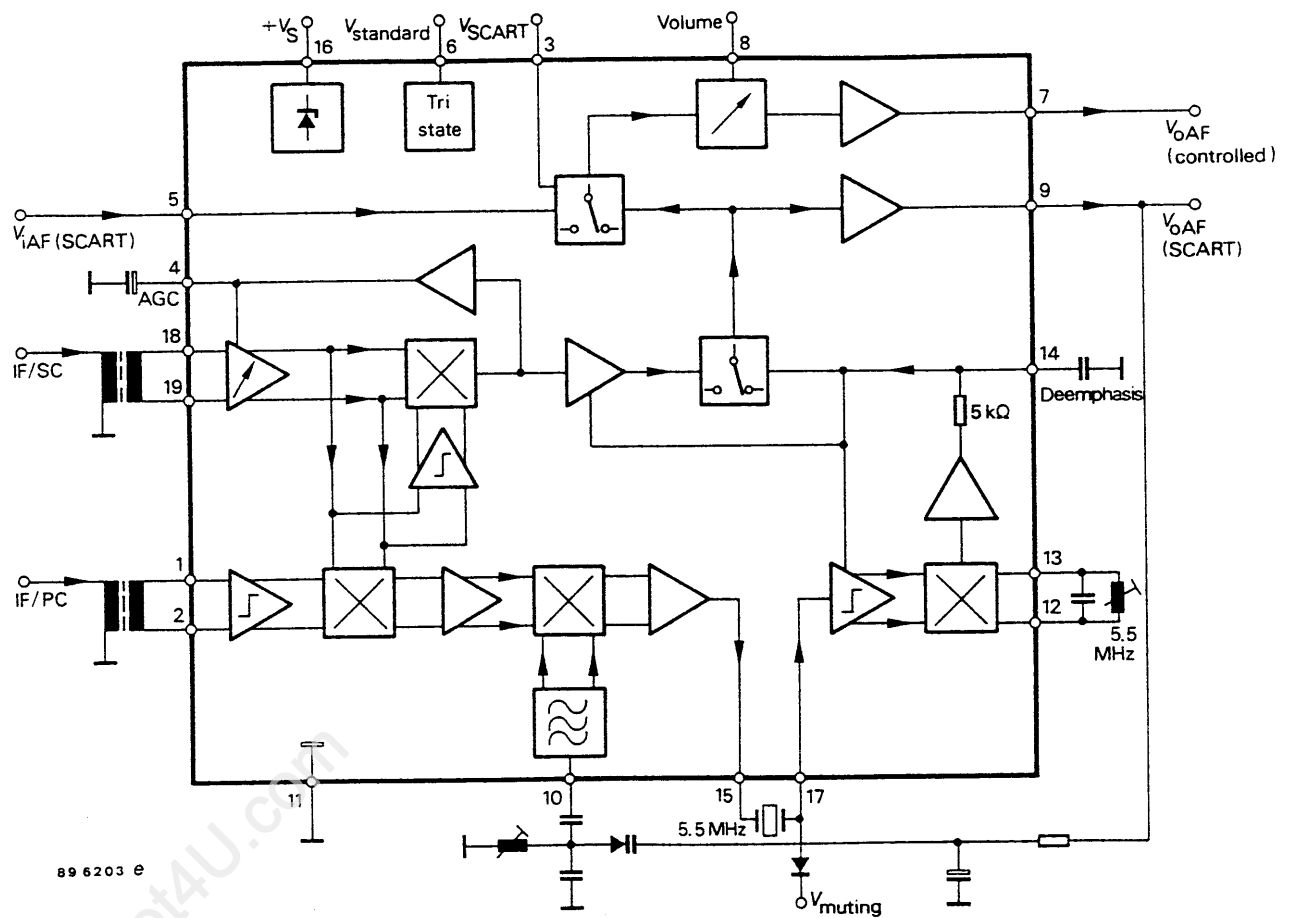

Figure 1 Block diagram

Pin Configuration

Pin	Function
1–2	Picture-IF-carrier input
3	SCART-switch
4	AGC storage capacitor
5	SCART-AF input
6	Standard switch
7	AF output (controlled)
8	Volume control voltage
9	SCART-AF output
10	VCO tank circuit

Pin	Function
11	Ground
12–13	FM demod. circuit 5.5 MHz
14	FM deemphasis capacitor
15	Intercarrier output 5.5 MHz
16	Supply voltage
17	Intercarrier input 5.5 MHz and muting
18–19	Sound-IF-carrier input
20	not connected

Description

This circuit configuration permits high-quality processing of audio carriers for all standards, providing separate inputs for the video and audio carriers. The audio carrier signal (FM or AM) is passed to two multiplying mixer arrangements via a 3-stage variable wide-band amplifier with levelled output signals. One mixer demodulates AM and generates the gain control signal. The second mixer operates as an intercarrier demodulator and supplies the intermediate AF carrier.

The video carrier signal required to form the intercarrier is decoupled in a prelimited and selected form from the demodulator tank of the intermediate video frequency circuit (TDA 4453 or TDA 4439) and led to the intercarrier mixer via a limiting amplifier. By virtue of the system, the Nyquist range of the IF input filter in the video channel affects the attainable AF signal-to-noise ratio.

The audio FM IF carrier reaches a quadrature demodulator via an interconnected IF-filter and subsequent limiting amplifier. The resulting AF signal is led via a low-pass

amplifier with increased level and the AF standard switch to the SCART switch. It is available at both AF outputs, regulated (pin 7) and unregulated (pin 9).

Pin 14 is provided to connect a de-emphasis capacitor (10 nF for 50 μ s). The de-emphasis is effective for both AF outputs during FM operation, but deactivated for AM operation.

A frequency converter is inserted to mix the different possible sound frequency standards (4.5, 6.0, 6.5 MHz) into a uniform intermediate audio frequency, e.g. 5.5 MHz. The VCO frequency (pin 10) can be controlled from the unlevelled AF output at pin 9 or the de-emphasis connection at pin 14.

The intercarrier and converter circuits as well as the FM demodulator are deactivated during AM modulation. FM muting is also possible if a switching voltage is applied to pin 17.

All switching functions (standard, SCART, mute) can take place with TTL-equivalent level.

Absolute Maximum Ratings

Reference point Pin 11, unless otherwise specified

Parameters	Symbol	Value	Unit
Supply voltage Pin 16	V_S	10 ... 13.5	V
Supply current Pin 16	I_S	80	mA
External voltages Pin 3,6 Pin 1,2,4,5,7,8,9,12, 13,14,15,16,17,18,19,	V_{ext}	V_5	V
	V_{ext}	6	V
Power dissipation (in soldered position)	P_{tot}	1	W
Junction temperature	T_j	125	°C
Ambient temperature range	T_{amb}	-25 to +70	°C
Storage temperature range	T_{stg}	-25 to +125	°C

Thermal Resistance

Parameters	Symbol	Value	Unit
Junction ambient	R_{thJA}	60	K/W

Electrical Characteristics

$V_S = 12$ V, $T_{amb} = 25^\circ\text{C}$, reference point Pin 20 (11), unless otherwise specified

Parameters	Test Conditions / Pins	Symbol	Min.	Typ.	Max.	Unit
Supply voltage range	Pin 16	V_S	10		13.5	V
Supply current						
FM-operation	Pin 16	I_S	65			mA
AM-operation	Pin 16		55			
Input DC voltage	Pin 5	V_o		4.4		V
Output DC voltage	Pin 7,9	V_o		3.7		
Standard switching voltage, Pin 6						
	Standard B/G Standard L converter operation	V	1.9 0 3.5	2.3	2.7 1.5 V_S	V
Standard switching current	$V_6 \leq 5$ V	I			20	μA
AGC range				65		dB
AM-operation						
Min. sound carrier input voltage	(AF-output voltage Pin 7, 9 -3 dB) Pin 18-19	v		50		μV
Audio output voltage	m = 54 % Pin 7, 9	v		500		mV
Harmonic distortion	f = 32.4 MHz, Pin 7, 9 f _{mod} = 1 kHz m = 30 % m = 80 %	THD		0.3 1.0	1.0 2.5	%

Parameters	Test Conditions / Pins	Symbol	Min.	Typ.	Max.	Unit
FM-operation						
Min. sound carrier input voltage	(intercarrier voltage -3 dB) Pin 18, 19	v		50		μV
Picture carrier input voltage	Pin 1-2	v	10	20	30	mV
Audio output voltage	$f_{\text{PC}} = 38.9 \text{ MHz}$, Pin 7, 9 $v_{1-2} = 20 \text{ mV}$, $f_{\text{SC}} = 33.4 \text{ MHz}$, $v_{18-19} = 10 \text{ mV}$, FM-deviation = 27 kHz, $f_{\text{mod}} = 1 \text{ kHz}$, $Q_{\text{B}} = 22$	v		500		mV
Harmonic distortion	$f_{\text{mod}} = 1 \text{ kHz}$, Pin 7, 9 $Q_{\text{B}} = 22$ FM-deviation = 30 kHz	d		0.5		%
Signal to noise ratio Standard B/G according to CCIR 468 specification	FM-deviation 30 kHz, $f_{\text{mod}} = 1 \text{ kHz}$ Pin 7, 9 Black burst Grid test signal	$\frac{(S+N)}{N}$		62 50		dB ¹⁾
AF amplifier – SCART-operation						
Volume control range	Pin 7			80		dB
V_8 for V_{AFmin} at Pin 7	Pin 8	V_8	0		0.5	V
V_8 for V_{AFmax} at Pin 7	Pin 8	V_8	4.5			V
SCART control voltage	Pin 3					
	recording	V_3	0		2	V
	playback	V_3	4			V
SCART input resistance	Pin 5	R_S		55		$\text{k}\Omega$
AF input voltage	THD $\leq 3\%$ Pin 5	v			2	V
SCART-amplification		G	-1	0	+1	dB
Attenuation	$v_5 = 500 \text{ mV}$, Pin 7, 9 $V_3 = 0 \text{ V}$	$\alpha_{7,9}$	60	75		dB
Muting on (AF off)	Pin 17	V_{17}	0		1	V
Switching current	Pin 17	I_{17}		600		μA
Muting off	voltage to diode Pin 17	V_{17}	4		V_S	V
Converter operation Pin 10						
DC at oscillator pin	$V_6 \geq 3.5 \text{ V}$	V_{10}		2.7		V
Oscillator frequency range		f	9		13	MHz ²⁾
Oscillator amplitude		v		400		mV ²⁾
Operation quality factor of external oscillator stage		Q_{B}	70			

1) Standard B/G IF-modulated-FBAS-signal

2) See application circuit

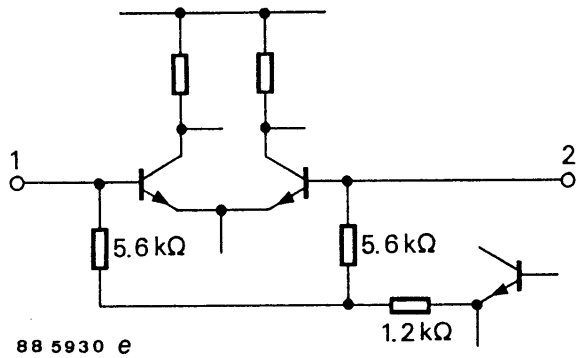

Pin 1,2
IF-input
vision carrier

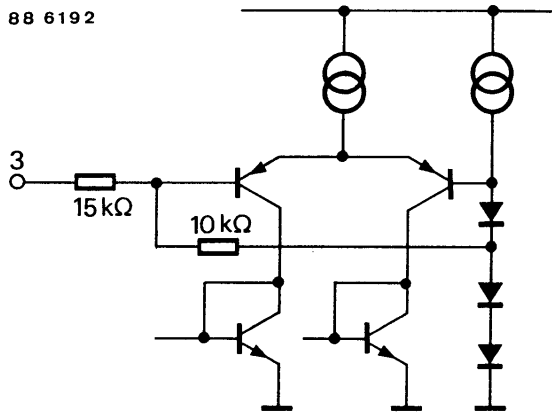

Pin 3
SCART switch

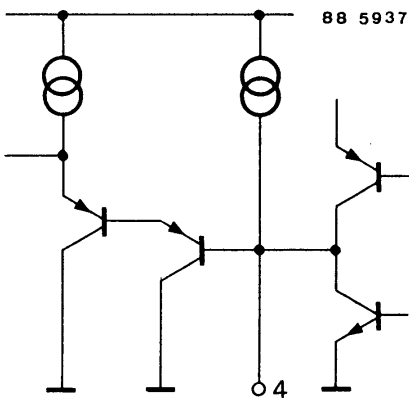

Pin 4
AGC storage capacitor

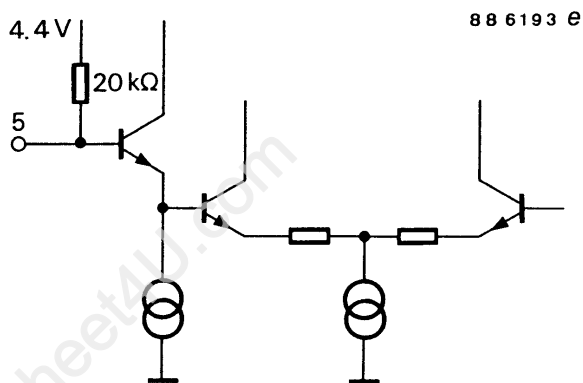

Pin 5
AF-input (SCART)

Pin 6
Standard switch

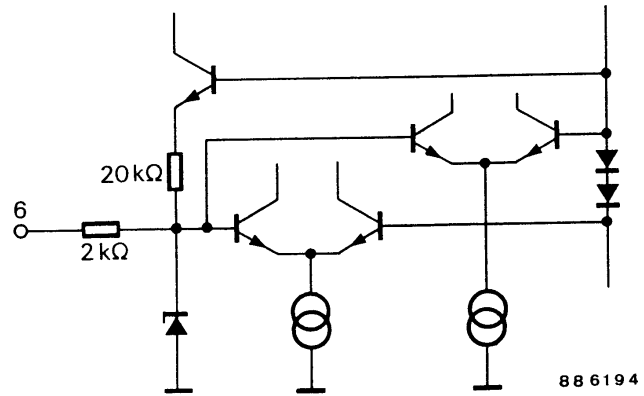

Pin 7
AF-input
controlled

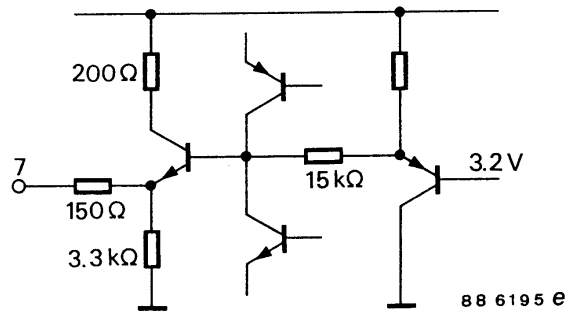

Pin 8
Volume control

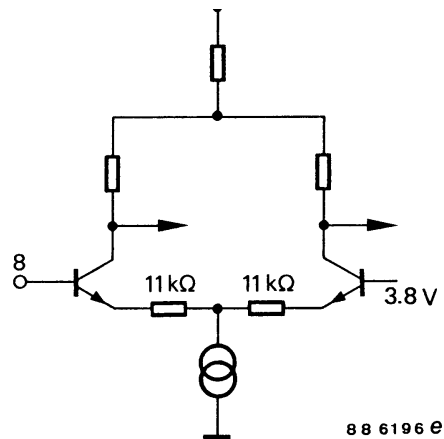

Pin 9
AF-output
uncontrolled

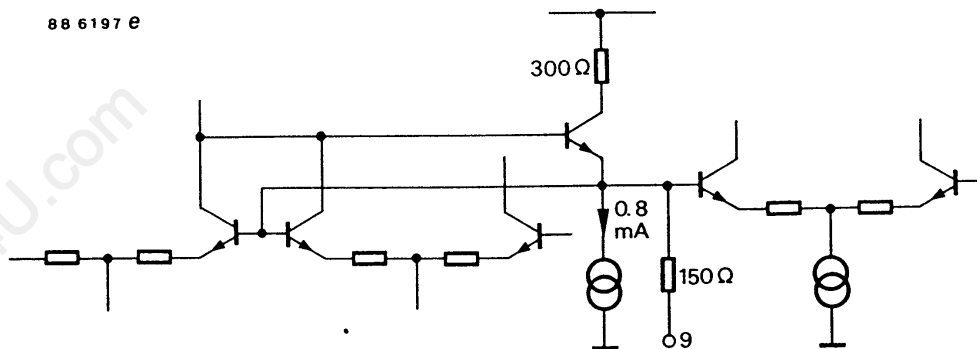

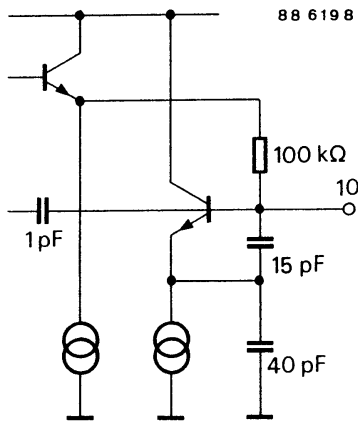

Pin 10
VCO tank circuit

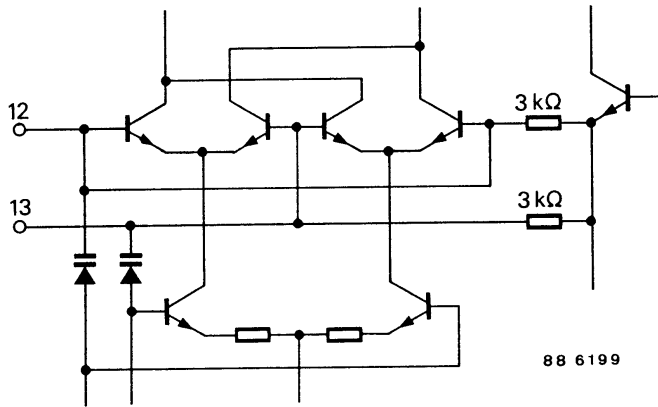

Pin 12,13
Demodulator tank circuit

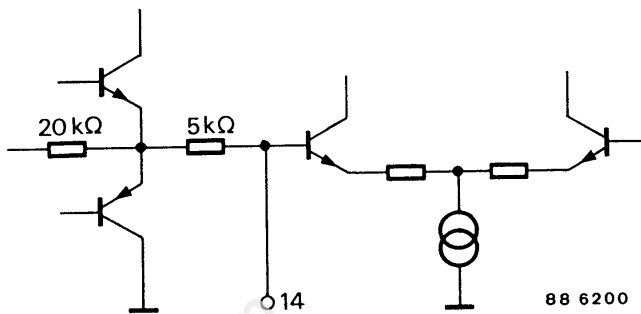

Pin 14
Deemphasis capacitor

TDA4481-D

Pin 15
Inter-carrier output
5.5 MHz

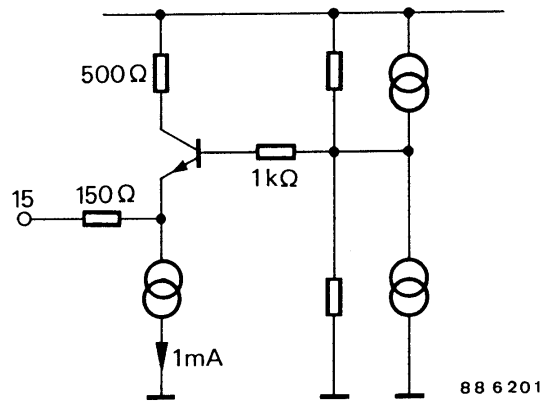

Pin 17
Inter-carrier input
5.5 MHz

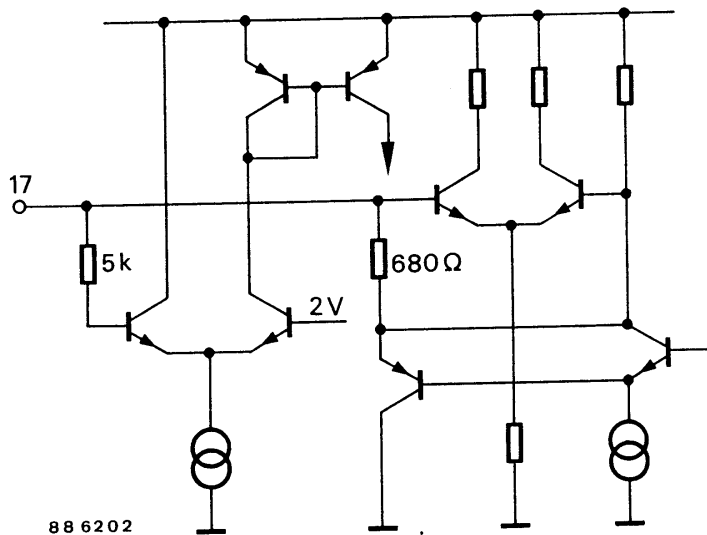

Pin 18,19
IF-input
sound carrier

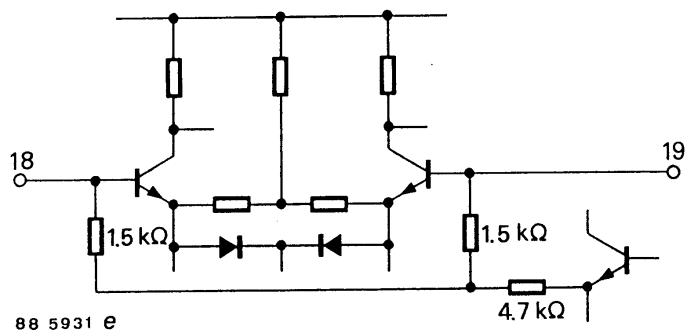

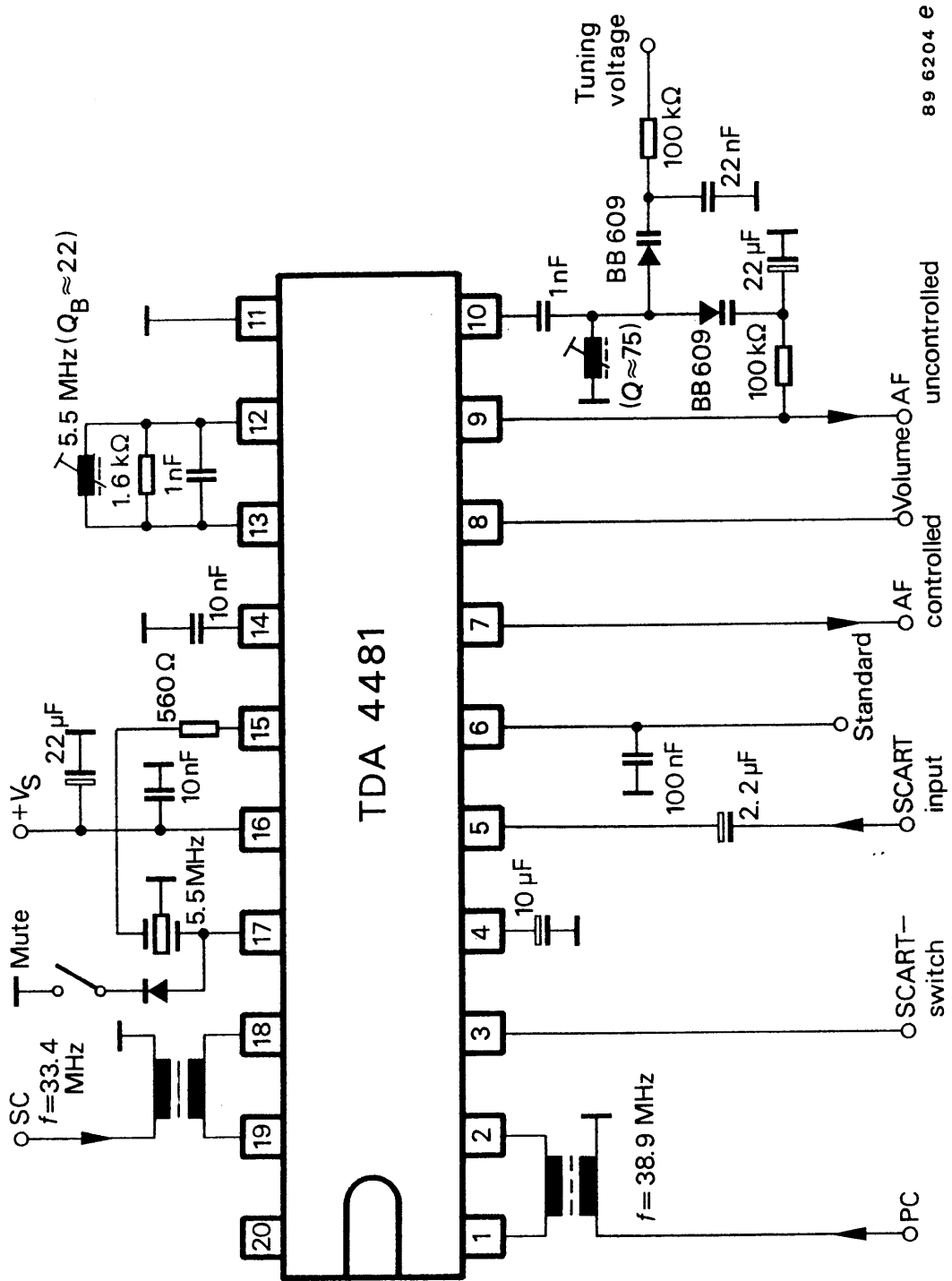

89 6204 e

Figure 2 Test circuit

TDA4481-D

Dimensions in mm

Package: DIP 20

