

DATA SHEET

TDA5155

**Pre-amplifier for Hard Disk Drive
(HDD) with MR-read/inductive write
heads**

Preliminary specification
File under Integrated Circuits, IC11

1997 Apr 08

**Pre-amplifier for Hard Disk Drive (HDD)
with MR-read/inductive write heads**

TDA5155**CONTENTS**

1	FEATURES
2	APPLICATIONS
3	GENERAL DESCRIPTION
4	ORDERING INFORMATION
5	QUICK REFERENCE DATA
6	BLOCK DIAGRAM
7	PINNING
8	FUNCTIONAL DESCRIPTION
8.1	Read mode
8.2	Write mode
8.3	Sleep mode
8.4	Standby mode
8.5	Active mode
8.6	Bi-directional serial interface
8.6.1	Addressing
8.6.2	Programming data
8.6.3	Reading data
8.7	Operation of the serial interface
8.7.1	Configuration
8.7.2	Power control
8.7.3	Head select
8.7.4	Servo write
8.7.5	Test
8.7.6	Write amplifier programmable capacitors
8.7.7	High frequency gain attenuator register
8.7.8	High frequency gain boost register
8.7.9	Settle pulse
8.7.10	Address registers summary
8.8	Head unsafe
8.9	HUS survey
9	LIMITING VALUES
10	HANDLING
11	THERMAL RESISTANCE
12	RECOMMENDED OPERATION CONDITIONS
13	CHARACTERISTICS
14	DEFINITIONS
15	LIFE SUPPORT APPLICATIONS

Pre-amplifier for Hard Disk Drive (HDD) with MR-read/inductive write heads

TDA5155

1 FEATURES

- Designed for 10 dual-stripe MR-read/inductive write heads
- Current bias-current sense architecture
- Single supply voltage (5.0 V \pm 10%); a separate write drivers supply pin can be biased from V_{CC} to 8 V +10%
- MR elements connected to ground (GND)
- Equal bias currents in the two MR stripes of each head
- On-chip AC couplings eliminate MR head DC offset
- 3-wire serial interface for programming
- Programmable voltage/current mode write data input
- Programmable high frequency zero-pole gain boost
- Programmable write driver compensation capacitance
- Programmable MR bias currents and write currents
- 1-bit programmable read gain
- Sleep, standby, active and test modes available
- Measurement of head resistances in test mode
- In test mode, one MR bias current may be forced to a minimum current
- Short write current rise and fall times with near rail-to-rail voltage swing
- Head unsafe pin for signalling of abnormal conditions and behaviour
- Low supply voltage write current inhibit (active or inactive)
- Support servo writing
- Provide temperature monitor
- Thermal asperity detection with programmable threshold level
- Requires only one external resistor.

2 APPLICATIONS

- Hard Disk Drive (HDD).

4 ORDERING INFORMATION

TYPE NUMBER	PACKAGE		
	NAME	DESCRIPTION	VERSION
TDA5155X	–	naked die	–

3 GENERAL DESCRIPTION

The 5.0 V pre-amplifier for HDD applications has been designed for five terminal, dual-stripe Magneto-Resistive (MR)-read/inductive write heads. The disks of the disk drive are connected to ground. To avoid voltage breakthrough between the heads and the disk, the MR elements of the heads are also connected to ground. The symmetry of the dual-stripe head-amplifier combination automatically distinguishes between the differential signals such as signals and the common-mode effects like interference. The latter are rejected by the amplifier.

The device incorporates read amplifiers, write amplifiers, a serial interface, digital-to-analog converters, reference and control circuits which all operate on a single supply voltage of 5 V \pm 10%. The output drivers have a separate supply voltage pin which can be connected to a higher supply voltage of up to 8 V +10%. The complementary output stages of the write amplifier allow writing with near rail-to-rail peak voltages across the inductive write head.

The read amplifier has low input impedance. The DC offset between the two stripes of the MR head is eliminated using on-chip AC coupling. Fast settling features are used to keep the transients short. As an option, the read amplifier may be left biased during writing so as to reduce the duration of these transients even further. Series inductance in the leads between the amplifier and MR heads influences the bandwidth which can be compensated by using a programmable high frequency gain boost (HF zero). HF noise and bandwidth can be attenuated using a programmable high frequency gain attenuator (HF pole).

On-chip digital-to-analog converters for MR bias currents and write currents are programmed via a 3-wire serial interface. Head selection, mode control, testing and servo writing can also be programmed using the serial interface. In sleep mode the CMOS serial interface is operational. Fig.1 shows the block diagram of the device.

Pre-amplifier for Hard Disk Drive (HDD) with MR-read/inductive write heads

TDA5155

5 QUICK REFERENCE DATA

SYMBOL	PARAMETER	CONDITIONS	MIN.	TYP.	MAX.	UNIT
V_{CC}	supply voltage		4.5	5.0	5.5	V
$V_{CC(WD)}$	supply voltage for write drivers		V_{CC}	8.0	8.8	V
$G_{V(dif)}$	differential voltage gain	from head inputs to RDx, RDy; $R_{MR} = 28 \Omega$; $I_{MR} = 10 \text{ mA}$ data bit d4 = 0 data bit d4 = 1	–	160	–	
			–	226	–	
B_{-3dB}	–3 dB frequency bandwidth	upper bandwidth without gain boost (4 nH lead inductance)	–	220	–	MHz
F	noise figure	$R_{MR} = 28 \Omega$; $I_{MR} = 10 \text{ mA}$; $T_{amb} = 25 \text{ }^\circ\text{C}$; $f = 20 \text{ MHz}$	–	3.0	3.2	dB
V_{in}	input referred noise voltage	$R_{MR} = 28 \Omega$; $I_{MR} = 10 \text{ mA}$; $T_{amb} = 25 \text{ }^\circ\text{C}$; $f = 20 \text{ MHz}$	–	0.9	1.0	nV/ $\sqrt{\text{Hz}}$
CMRR	common mode rejection ratio R_{MR} mismatch <5%	$I_{MR} = 10 \text{ mA}$ $f < 1 \text{ MHz}$ $f < 100 \text{ MHz}$	–	45	–	dB
			–	25	–	dB
PSRR	power supply rejection ratio (input referred) R_{MR} mismatch <5%	$I_{MR} = 10 \text{ mA}$ $f < 1 \text{ MHz}$ $f < 100 \text{ MHz}$	–	80	–	dB
			–	50	–	dB
t_r, t_f	write current rise/fall time (10% to 90%)	$L_h = 150 \text{ nH}$; $R_h = 10 \Omega$; $I_{WR} = 35 \text{ mA}$; $f = 20 \text{ MHz}$ $V_{CC(WD)} = 8.0 \text{ V}$ $V_{CC(WD)} = 6.5 \text{ V}$	–	–	1.8	ns
			–	–	2.1	ns
$I_{MR(PR)}$	programming MR bias current range	$R_{ext} = 10 \text{ k}\Omega$	5	–	20.5	mA
$I_{WR(b-p)}$	programming write current range (base-to-peak)	$R_{ext} = 10 \text{ k}\Omega$	20	–	51	mA
f_{SCLK}	serial interface clock rate		–	–	25	MHz

Pre-amplifier for Hard Disk Drive (HDD) with MR-read/inductive write heads

TDA5155

6 BLOCK DIAGRAM

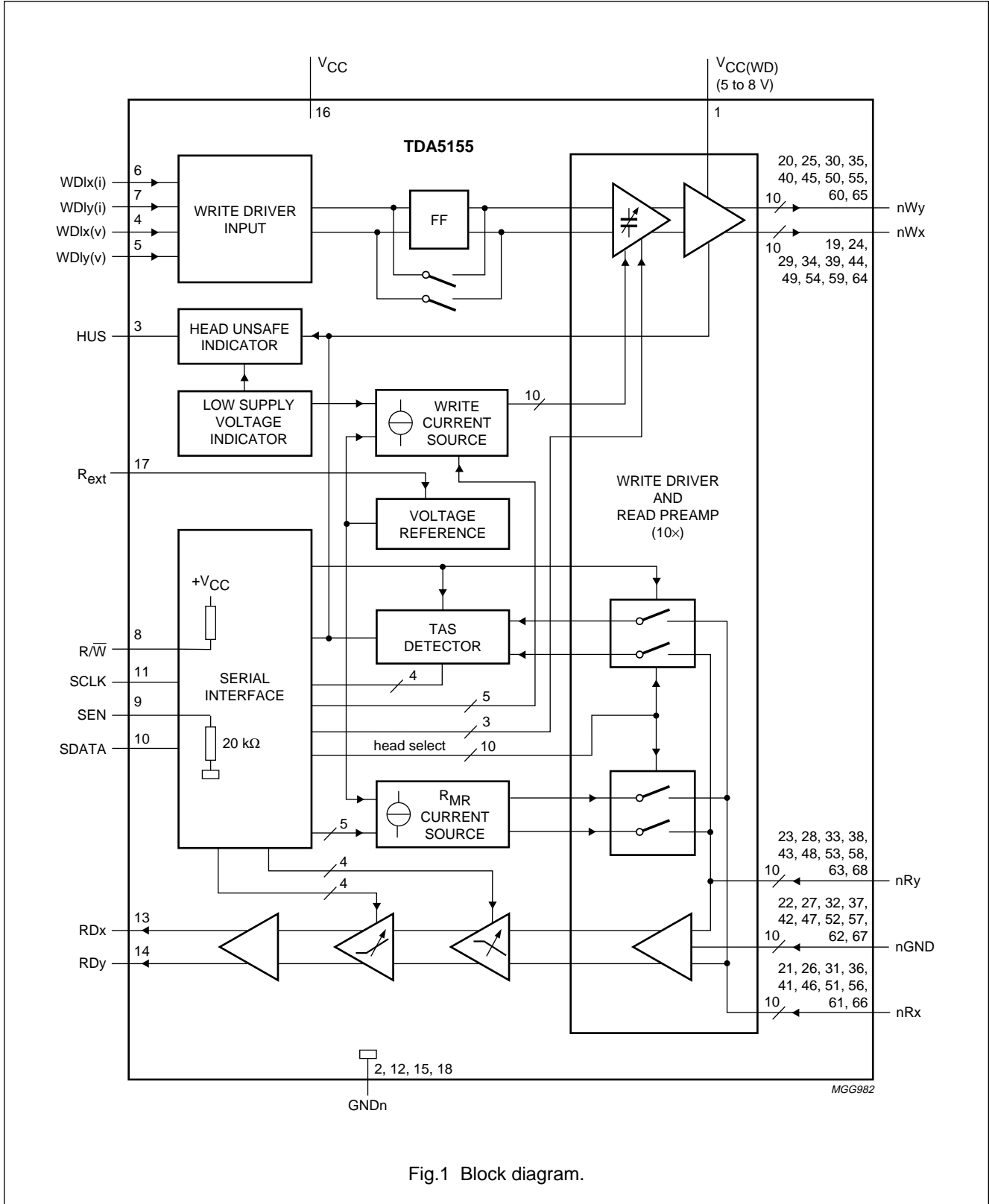

Fig.1 Block diagram.

Pre-amplifier for Hard Disk Drive (HDD) with MR-read/inductive write heads

TDA5155

7 PINNING

SYMBOL	PAD	DESCRIPTION
V _{CC(WD)}	1	supply voltage for the write drivers
GND1	2	ground connection 1
HUS	3	head unsafe output
WDIx(v)	4	write data input (differential, voltage input)
WDIy(v)	5	write data input (differential, voltage input)
WDIx(i)	6	write data input (differential, current input)
WDIy(i)	7	write data input (differential, current input)
R _W	8	read/write (read = active HIGH, write = active LOW)
SEN	9	serial bus enable
SDATA	10	serial bus data
SCLK	11	serial bus clock
GND2	12	ground connection 2
RDx	13	read data output (differential x – y)
RDy	14	read data output (differential x – y)
GND3	15	ground connection 3
V _{CC}	16	supply voltage
R _{ext}	17	10 kΩ external resistor
GND4	18	ground connection 4
0Wx	19	inductive write head connection for head H0 (differential x – y)
0Wy	20	inductive write head connection for head H0 (differential x – y)
0Rx	21	MR-read head connection for head H0 (differential x – y)
0GND	22	ground connection for head H0
0Ry	23	MR-read head connection for head H0 (differential x – y)
1Wx	24	inductive write head connection for head H1 (differential x – y)
1Wy	25	inductive write head connection for head H1 (differential x – y)
1Rx	26	MR-read head connection for head H1 (differential x – y)
1GND	27	ground connection for head H1
1Ry	28	MR-read head connection for head H1 (differential x – y)
2Wx	29	inductive write head connection for head H2 (differential x – y)

SYMBOL	PAD	DESCRIPTION
2Wy	30	inductive write head connection for head H2 (differential x – y)
2Rx	31	MR-read head connection for head H2 (differential x – y)
2GND	32	ground connection for head H2
2Ry	33	MR-read head connection for head H2 (differential x – y)
3Wx	34	inductive write head connection for head H3 (differential x – y)
3Wy	35	inductive write head connection for head H3 (differential x – y)
3Rx	36	MR-read head connection for head H3 (differential x – y)
3GND	37	ground connection for head H3
3Ry	38	MR-read head connection for head H3 (differential x – y)
4Wx	39	inductive write head connection for head H4 (differential x – y)
4Wy	40	inductive write head connection for head H4 (differential x – y)
4Rx	41	MR-read head connection for head H4 (differential x – y)
4GND	42	ground connection for head H4
4Ry	43	MR-read head connection for head H4 (differential x – y)
5Wx	44	inductive write head connection for head H5 (differential x – y)
5Wy	45	inductive write head connection for head H5 (differential x – y)
5Rx	46	MR-read head connection for head H5 (differential x – y)
5GND	47	ground connection for head H5
5Ry	48	MR-read head connection for head H5 (differential x – y)
6Wx	49	inductive write head connection for head H6 (differential x – y)
6Wy	50	inductive write head connection for head H6 (differential x – y)
6Rx	51	MR-read head connection for head H6 (differential x – y)
6GND	52	ground connection for head H6
6Ry	53	MR-read head connection for head H6 (differential x – y)
7Wx	54	inductive write head connection for head H7 (differential x – y)

Pre-amplifier for Hard Disk Drive (HDD)
with MR-read/inductive write heads

TDA5155

SYMBOL	PAD	DESCRIPTION
7Wy	55	inductive write head connection for head H7 (differential x – y)
7Rx	56	MR-read head connection for head H7 (differential x – y)
7GND	57	ground connection for head H7
7Ry	58	MR-read head connection for head H7 (differential x – y)
8Wx	59	inductive write head connection for head H8 (differential x – y)
8Wy	60	inductive write head connection for head H8 (differential x – y)
8Rx	61	MR-read head connection for head H8 (differential x – y)

SYMBOL	PAD	DESCRIPTION
8GND	62	ground connection for head H8
8Ry	63	MR-read head connection for head H8 (differential x – y)
9Wx	64	inductive write head connection for head H9 (differential x – y)
9Wy	65	inductive write head connection for head H9 (differential x – y)
9Rx	66	MR-read head connection for head H9 (differential x – y)
9GND	67	ground connection for head H9
9Ry	68	MR-read head connection for head H9 (differential x – y)

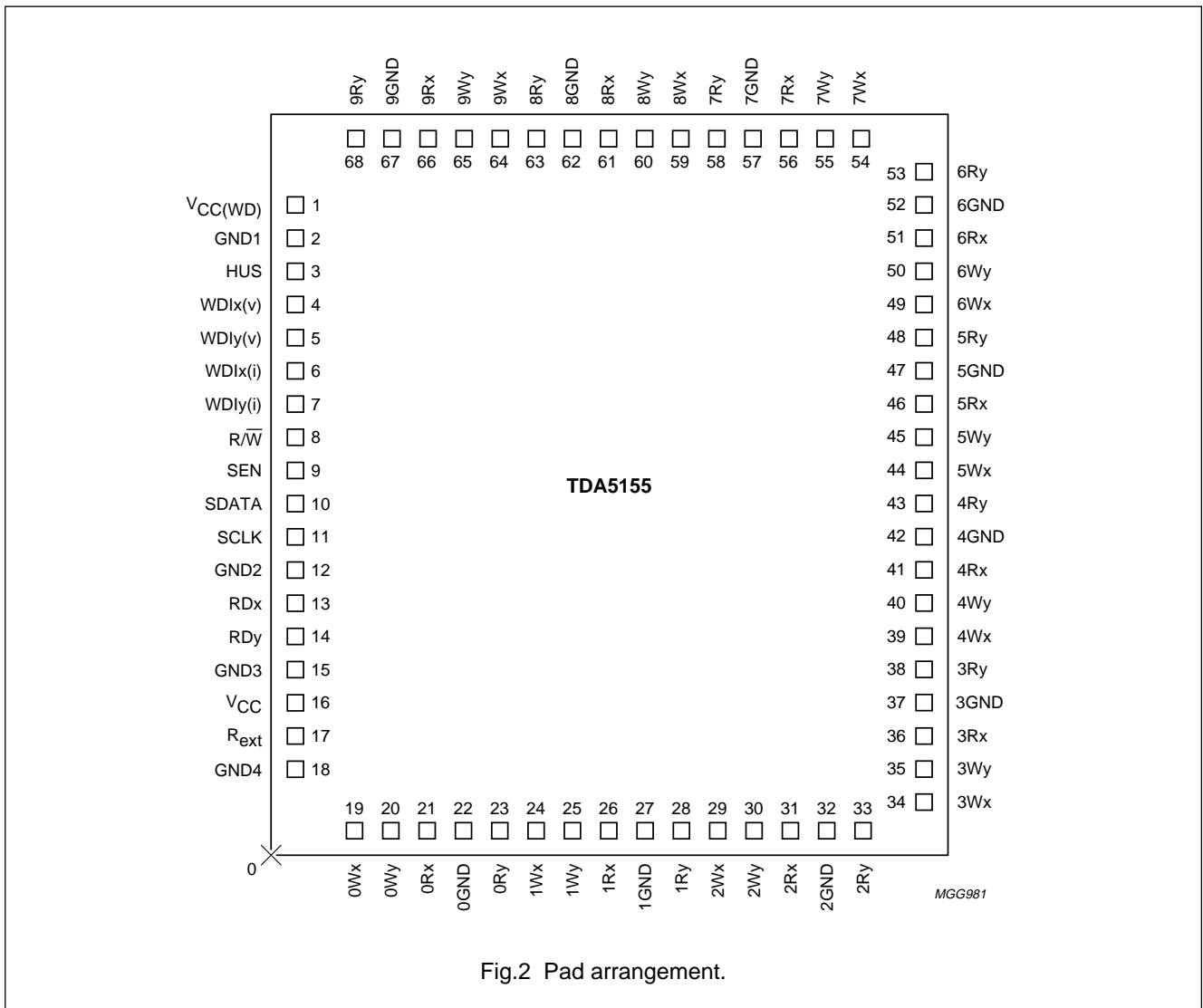

Fig.2 Pad arrangement.

Pre-amplifier for Hard Disk Drive (HDD) with MR-read/inductive write heads

TDA5155

8 FUNCTIONAL DESCRIPTION

8.1 Read mode

The read mode disables the write circuitry to save power while reading. The read circuitry is deactivated for write, sleep and standby modes. The read circuitry may also be biased during write mode to shorten transients.

The selected head is connected to a multiplexed low-noise read amplifier. The read amplifier has low-impedance inputs nRx and nRy (n is the number of the head) and low-impedance outputs RDx and RDy. The signal polarity is non-inverting from x and y inputs to x and y outputs.

Ambient magnetic fields at the MR elements result in a relative change in MR resistance:

$$\frac{dR_{MR}}{R_{MR}}$$

This change produces a current variation:

$$dI_{MR} = I_{MR} \times \frac{dR_{MR}}{R_{MR}},$$

where I_{MR} is the bias current in the MR element.

The current variation is amplified to form the read data output signal voltage, which is available at RDx and RDy. AC coupling between MR elements and amplifier stages prevents the amplifier input stages from overloading by DC voltages across the MR elements. A fast settling procedure shortens DC settling transients.

An on-chip generated stable temperature reference voltage (1.32 V), available at the R_{ext} pin, is dropped across an external resistor (10 k Ω) to form a global reference current for the write and the MR bias currents. The MR bias current DACs are programmed through the serial interface according to the following formula:

$$I_{MR} = 0.5 \times \frac{10k\Omega}{R_{ext}} (10 + 16d4 + 8d3 + 4d2 + 2d1 + d0)$$

(in mA), where d4-d0 are bits (either logic 0 or logic 1). At power-up all bits are set to logic 0, which results in a default MR current of 5 mA. The adjustable range of the MR currents is 5 mA to 20.5 mA. The MR bias currents are equal for the two stripes of each head. The gain amplifier is 1-bit programmable. The amplifier gain can be set to its nominal value or to the nominal value +3 dB.

8.2 Write mode

To minimize power dissipation, the read circuitry may be disabled in write mode. The write circuitry is disabled in read, sleep and standby modes. In write mode, a programmable current is forced through the selected two-terminal inductive write head. The push-pull output drivers yield near rail-to-rail voltage swings for fast current polarity switching.

The write data input can be either voltage or current input (see Chapter 12). In voltage mode, the differential write data inputs WDlx(v) and WDly(v) are PECL (Positive Emitter Coupled Logic) compatible. The write data flip-flop can either be used or passed-by. In the case that the write data flip-flop is used, current polarity is toggled at the falling edges of

$$V_{data} = \frac{V_{WDlx(v)} - V_{WDly(v)}}{2}$$

Switching to write mode initializes the data flip-flop so that the write current flows in the write head from x to y. In the case that the write data flip-flop is not used, the signal polarity is non-inverting from x and y inputs to x and y outputs.

The write current magnitude is controlled through on-chip DACs. The write current is defined as follows:

$$I_{WR} = \frac{10k\Omega}{R_{ext}} (20 + 16d4 + 8d3 + 4d2 + 2d1 + d0)$$

(in mA), where d4-d0 are bits (either logic 0 or logic 1). The adjustable range of the write current is 20 mA to 51 mA. At power-up, the default values $d4 = d3 = d2 = d1 = d0 = \text{logic } 0$ are initialized, corresponding to $I_{WR} = 20$ mA. I_{WR} is the current provided by the write drivers: the current in the write coil and in the damping resistor together. The static current in the write coil is

$$\frac{I_{WR}}{1 + \frac{R_h}{R_d}},$$

where R_h is the resistance of the coil including leads and R_d is the damping resistor.

Pre-amplifier for Hard Disk Drive (HDD) with MR-read/inductive write heads

TDA5155

8.3 Sleep mode

In sleep mode, the device is accessible via the serial interface. All circuits are inactive, except the circuits of the CMOS serial interface and the circuitry which forces the data registers to their default values at power-up and which fixes the DC level of outputs RDx and RDy (required when operating with more than one amplifier). Typical static current consumption is $-30\ \mu\text{A}$. Dynamic current consumption during operation of the serial interface in sleep mode due to external activity at the inputs to the serial interface is not included. In all modes, including the sleep mode, data registers can be programmed. Sleep is the default mode at power-up. Switching to other modes takes less than 0.1 ms.

8.4 Standby mode

The circuit can be put in standby mode using the serial interface. In standby mode, the typical DC current consumption is $330\ \mu\text{A}$. Transients from standby mode to active mode are two orders of magnitude shorter than from sleep mode to active mode. This is important in the case of cylinder mode operation with multiple amplifiers. All amplifiers can operate from standby mode and all head switch times can be kept just as short as in the case of operation with a single amplifier. Head switch times are summarized in the switching characteristics.

8.5 Active mode

Active mode is either read mode or write mode depending on the status of the $\overline{\text{R/W}}$ pin.

8.6 Bi-directional serial interface

The serial interface is used for programming the device and for reading of status information. 16 bits (8 bits for data and 8 for address) are used to program the device. The serial interface requires 3 pins: SDATA, SCLK and SEN. These pins (and $\overline{\text{R/W}}$ as well) are CMOS inputs. The logic input $\overline{\text{R/W}}$ has an internal $20\ \text{k}\Omega$ pull-up resistor and the SEN logic input has an internal $20\ \text{k}\Omega$ pull-down resistor. Thus, in case the SEN line is opened, no data will be registered and in case the $\overline{\text{R/W}}$ line is opened, the device will never be in write mode.

SDATA: serial data; bi-directional data interface. In all circumstances, **the LSB is transmitted first.**

SCLK: serial clock; 25 MHz clock frequency.

SEN: serial enable; data transfer takes place when SEN is HIGH. When SEN is LOW, data and clock signals are prohibited from entering the circuit.

Three phases in the communication are distinguishable: addressing, programming and reading. Each communication sequence starts with an addressing phase, followed by either a programming phase or a reading phase.

8.6.1 ADDRESSING

When SEN goes HIGH, bits are latched in at rising edges of SCLK. The first eight bits a7 to a0 (starting with a0) are shifted serially into an address register. If SEN goes LOW before 16 bits have been received, the operation is ignored. When more than 16 bits (address and data) are latched in before SEN goes LOW, the first 8 bits are interpreted as an address and the last 8 bits as data. SEN should go HIGH at least 5 ns before the first rising edge of SCLK. Data should be valid at least 5 ns before and after a rising edge of SCLK. The first six bits a5 to a0 constitute the register address. Bit a6 is unused. If bit a7 = logic 0, a PROGRAMMING sequence starts. If bit a7 = logic 1, READING data from the pre-amplifier can start.

8.6.2 PROGRAMMING DATA

If a7 = 0, the last eight bits d7 to d0 before SEN goes LOW are shifted into an input register. When SEN goes LOW, the communication sequence is ended and the data in the input register is copied in parallel to the data register that corresponds to the decoded address a0 to a5. SEN should go LOW at least 5 ns after the last rising edge of SCLK. See Fig.3 for the timing diagram of the programming.

8.6.3 READING DATA

Immediately after the IC detects that a7 = logic 1, data from the data register (address a5 to a0) is copied in parallel to the input register. Two wait clock cycles must follow before the controller can start inputting data. At the first falling edge of SCLK after the 2 wait rising edges of SCLK, the LSB d0 is placed on SDATA line followed by d1 at the next falling edge of SCLK etc. If SEN goes LOW before 8 address bits (a7 to a0) have been detected, the communication is ignored. If SEN goes LOW before the 8 data bits have been sent out of the IC, the reading sequence is immediately interrupted. See Fig.4 for the timing diagram of the reading via the serial interface.

Pre-amplifier for Hard Disk Drive (HDD)
with MR-read/inductive write heads

TDA5155

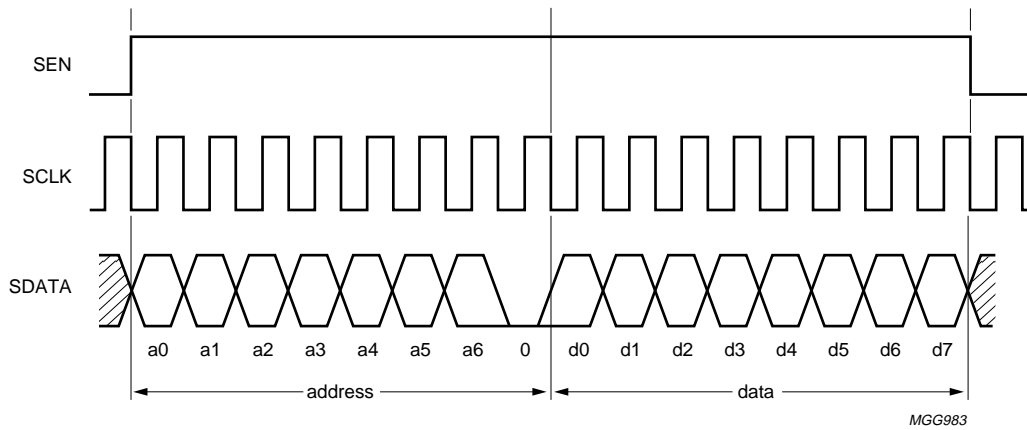

Fig.3 Timing diagram of the write sequence of the serial interface operation (a7 = logic 0).

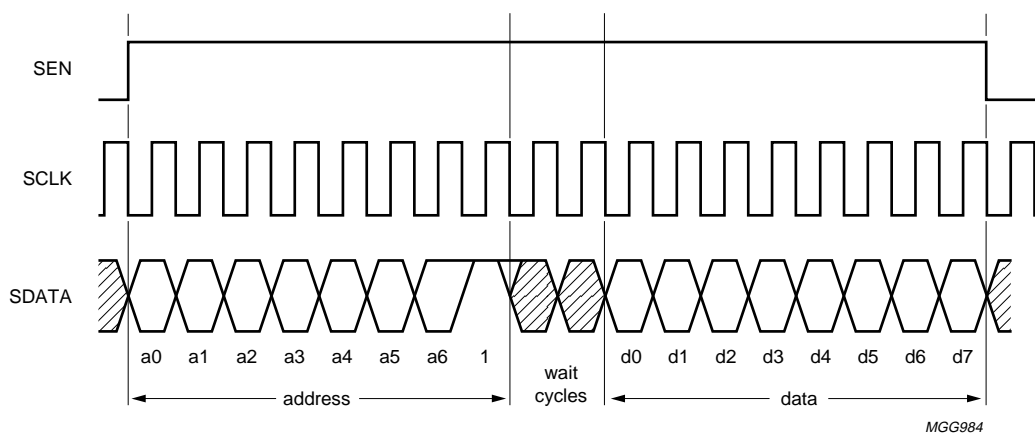

Fig.4 Timing diagram of the read sequence of the serial interface operation a7 = logic 1).

Pre-amplifier for Hard Disk Drive (HDD) with MR-read/inductive write heads

TDA5155

8.7 Operation of the serial interface

The serial interface programming is summarized in Section 8.7.10.

8.7.1 CONFIGURATION

d0:

By default (d0 = logic 0), write data passes from the write data input via the data flip-flop to the write driver. The write driver toggles the current in the head at the falling edges of:

$$V_{\text{data}} = \frac{V_{\text{WDIx}(v)} - V_{\text{WDIy}(v)}}{2} \text{ or}$$

$$I_{\text{data}} = \frac{I_{\text{WDIx}(i)} - I_{\text{WDIy}(i)}}{2}$$

When d0 = logic 1, the write data flip-flop is not used. The signal polarity is non-inverting from the inputs WDIx and WDIy to the outputs nWx and nWy.

d1:

By default (d1 = logic 0), the pre-amplifier senses PECL write signals at WDIx(v) and WDIy(v). When d1 = logic 1, the pre-amplifier senses input write currents at WDIx(i) and WDIy(i).

d2:

By default (d2 = logic 0), the write current is inhibited under low supply voltage conditions. The write current inhibit is made inactive by programming d2 to logic 1.

d3:

By default (d3 = logic 0), in write mode low supply voltage, open head, and other conditions are monitored and flagged at HUS. If d3 = logic 1, HUS is LOW in write mode and HIGH in read mode.

d4:

The amplifier read gain may be programmed in the configuration register. By default (d4 = logic 0), the read gain is typically 160 with $R_{\text{MR}} = 28 \Omega$. If d4 = logic 1, the read amplifier gain is 3 dB higher (226 in this case).

d5:

In order to minimize the write-to-read recovery times, the first stage of the read amplifier may be kept biased during write mode. By default, (d5 = logic 0) the read amplifier is powered down during write mode, and the fast settling procedure is activated after write-to-read switching. If d5 = logic 1 the read amplifier is kept biased during write mode, and the fast settling procedure still occurs if the head is changed or the MR current is re-programmed.

8.7.2 POWER CONTROL

By default, d1 = d0 = logic 0, the pre-amplifier powers up in sleep mode. If d1 = logic 0, d0 = logic 1 or d1 = logic 1, d0 = logic 0 the circuit goes in standby mode. If d1 = d0 = logic 1, the circuit goes in active mode (read or write mode depending on the R/\overline{W} input).

8.7.3 HEAD SELECT

Selection of a wrong head (H10-H15) causes an head unsafe condition. HUS goes HIGH when in write mode a wrong head is selected and when d3 in the configuration register is LOW. When in read mode and a wrong head is selected, head H0 is therefore selected and if d3 in the configuration register is LOW, HUS goes LOW.

8.7.4 SERVO WRITE

The circuit is prepared for servo writing. However, the device will not be guaranteed.

8.7.5 TEST

d2 = d1 = d0 = logic 0. The circuit is not in test mode. This is the default situation.

8.7.5.1 MR head test

d2 = logic 0, d1 = logic 0, d0 = logic 1. In read mode, the voltages at Rx and Ry (at the top of the MR elements) of the selected head are fed to outputs RDx and RDy. By measuring the output voltages single ended at two different I_{MR} currents, the MR resistance can be accurately measured according to the following formula:

$$R_{\text{MRx}} = \frac{V_{\text{RDx1}} - V_{\text{RDx2}}}{I_{\text{MRx1}} - I_{\text{MRx2}}} \text{ for the x-side.}$$

Open head and head short-circuited-to-ground conditions can therefore be detected.

d2 = logic 0, d1 = logic 1, d0 = logic 0. Same as before, with the difference that I_{MR2} is fixed to a minimum constant value of 5 mA. Measuring in the same way as above with $I_{\text{MR1}} > 5 \text{ mA}$, enables the detection of MR elements shorted together.

8.7.5.2 Temperature monitor

d2 = logic 0, d1 = logic 1, d0 = logic 1. The temperature monitor voltages are connected to RDx and RDy. The output differential voltage depends on the temperature according to: $dV = -0.00364 \times T + 1.7$; $0 < T < 140 \text{ }^\circ\text{C}$. The temperature may be measured with a typical precision of 5 $^\circ\text{C}$.

Pre-amplifier for Hard Disk Drive (HDD) with MR-read/inductive write heads

TDA5155

8.7.5.3 Thermal asperity detector

d2 = logic 1, d1 = x, d0 = (0,1). Unlike the above tests, the thermal asperity detection does not use the RDx and RDy outputs. Thus, the reader is fully operational. In case a thermal asperity is detected, it is flagged at the HUS pin.

The threshold voltage for the thermal asperity detection is 2-bit programmable. These 2 bits consist of d0 (LSB) of the test mode register (address = 0xxx0110), and d2 of the compensation capacitor register (address = 0xxx0111).

$$V_{th} = (210 + 560.d0 + 280.d2) \mu V$$

d0 of test mode register;

d2 of the compensation capacitor register.

8.7.6 WRITE AMPLIFIER PROGRAMMABLE CAPACITORS

By default (d2 = d1 = d0 = logic 0) the programmable capacitors are zero. These capacitors are used to improve the performance of the write amplifier according to the write amplifier output load.

8.7.7 HIGH FREQUENCY GAIN ATTENUATOR REGISTER

By default (d3 = d2 = d1 = d0 = logic 0) the high frequency gain attenuator is not active. The gain attenuator provides a pole which limits the bandwidth and reduces the high

frequency noise. The HF pole can be used in combination with the HF zero in order to boost the HF gain locally and yet limit the very high frequency noise enhancement.

8.7.8 HIGH FREQUENCY GAIN BOOST REGISTER

By default (d3 = d2 = d1 = d0 = logic 0) the high frequency gain boost is not active.

The gain boost provides a zero which allows to optimize the bandwidth of the read amplifier and to correct for attenuation caused by series inductances in the leads between the MR heads and the read amplifier inputs.

8.7.9 SETTLE PULSE

By default (d2 = d1 = d0 = logic 0) the settle pulse has a nominal duration of 3 μs. Its value can be programmed from 2.125 μs to 3 μs according to the following formula:

$$t_{st} = 2\mu s + \frac{1}{(4.d2 + 2.d1 + 1.d0 + 1)} \mu s$$

The settle pulse is used to shorten the transients during switching.

8.7.10 ADDRESS REGISTERS SUMMARY

ADDRESS REGISTERS ⁽¹⁾								FUNCTION
A7	A6	A5	A4	A3	A2	A1	A0	
0	X	X	X	0	0	0	0	configuration register: d0 = 0: use data flip-flop; d0 = 1: by-pass data flip-flop d1 = 0: WDI PECL; d1 = 1: current input d2 = 0: write current inhibit active; d2 = 1: write current inhibit inactive read mode: d3 = 0: HUS active; d3 = 1: HUS HIGH write mode: d3 = 0: HUS active; d3 = 1: HUS LOW d4 = 0: read gain nominal; d3 = 1: read gain +3 dB d5 = 0: read amplifier OFF during write mode; d5 = 1: read amplifier ON during write mode
0	X	X	X	0	0	0	1	power control register: (d1,d0) = (0,0): sleep mode (d1,d0) = (1,0) or (0,1): standby mode (d1,d0) = (1,1): active mode (write or read)
0	X	X	X	0	0	1	0	head select register: (d3,d2,d1,d0) = (0,0,0,0) to (1,0,0,1): H0 to H9 addressing H10 to H15 causes HUS to go HIGH if in write mode and H0 to be selected if in read mode

Pre-amplifier for Hard Disk Drive (HDD)
with MR-read/inductive write heads

TDA5155

ADDRESS REGISTERS ⁽¹⁾								FUNCTION
A7	A6	A5	A4	A3	A2	A1	A0	
0	X	X	X	0	0	1	1	MR current DAC register: $I_{MR} = 0.5 \times \frac{10k\Omega}{R_{ext}} (10 + 16.d4 + 8.d3 + 4.d2 + 2.d1 + d0)$ mA
0	X	X	X	0	1	0	0	write current DAC register: $I_{WR} = \frac{10k\Omega}{R_{ext}} (20 + 16.d4 + 8.d3 + 4.d2 + 2.d1 + d0)$ mA
0	X	X	X	0	1	0	1	servo write register: (d0,d1) = (0,0): one head (d0,d1) = (1,1): all heads (d0,d1) = (1,0): odd numbered heads (H1, H3, H5, H7 and H9) (d0,d1) = (0,1): even numbered heads (H0, H2, H4, H6 and H8)
0	X	X	X	0	1	1	0	test mode register: (d2,d1,d0) = (0,0,0) = not in test mode (d2,d1,d0) = (0,0,1) = read head test ($I_{MR1} = I_{MR2}$) (d2,d1,d0) = (0,1,0) = read head test ($I_{MR2} = 5$ mA fixed) (d2,d1,d0) = (0,1,1) = temperature monitor (d2,d1,d0) = (1,X,d0) = thermal asperity detection, see note 2 $V_{th} = (210 + 560.d0 + 280.d2)$ μ V
0	X	X	X	0	1	1	1	compensation capacitor register: equivalent differential capacitance = $(4.d2 + 2.d1 + 1.d0) \times 2$ pF
0	X	X	X	1	0	0	0	high frequency gain attenuator register nominal pole frequency = $\frac{800 \text{ MHz}}{8.d3 + 4.d2 + 2.d1 + 1.d0}$
0	X	X	X	1	0	0	1	high frequency gain boost register nominal zero frequency = $\frac{800 \text{ MHz}}{8.d3 + 4.d2 + 2.d1 + 1.d0}$
0	X	X	X	1	0	1	0	settle time register settle time: $t_{st} = 2\mu s + \frac{1}{(4.d2 + 2.d1 + 1.d0 + 1)} \mu s$
1	X	X	X	1	1	1	1	device ID register ID = $8.d3 + 4.d2 + 2.d1 + 1.d0$; d3 to d0 are preset to (0,0,1,1)
1	X	X	X	a3	a2	a1	a0	when a7 = 1, data from the register with address a3 to a0 is read out on SDATA

Notes

- Unused bits in the registers (indicated by X) are don't care. Default data, initialized at Power-up, is zero in all registers. For $V_{CC} < 2.5$ V, the register contents are not guaranteed.
- V_{th} programming uses both the test mode register and the compensation capacitor register. d0 in the formula above is the LSB of the test mode register and d2 is the d2 data bit of the compensation capacitor register.

Pre-amplifier for Hard Disk Drive (HDD) with MR-read/inductive write heads

TDA5155

8.8 Head unsafe

The HUS pin is an open collector output. Therefore when the pin is not connected to an external pull-up resistor, HUS is LOW. HUS pins can be connected together in case of operation with more than one amplifier. It is used to detect abnormal or unexpected operation.

Sleep mode: HUS is HIGH, to permit working with more than one amplifier.

Standby mode: HUS is HIGH, to permit working with more than one amplifier.

Read mode:

- If in the configuration register d3 = 1, HUS is HIGH
- If in the configuration register d3 = 0, HUS goes LOW for:
 - Selection of a wrong head (H10 to H15)⁽¹⁾
 - R_{ext} pin open, short-circuited to ground or to V_{CC} (read current too low or too high)
 - Low V_{CC} and V_{CC(WD)} conditions. A low supply voltage detector is placed close to the V_{CC} and V_{CC(WD)} pins.

Detection of low V_{CC} (main supply): a V_{CC} supply voltage below 4.0 V ±5% is flagged at the HUS pin. The voltage detection range is then 4.2 to 3.8 V with an hysteresis of 110 mV ±10%. Detection of low V_{CC(WD)} (write drivers supply): a fault will be flagged at the HUS pin if V_{CC(WD)} drops 0.8 V ±10% below V_{CC}. One must be aware that such a detection is only aimed to warn for a catastrophic situation. Indeed, V_{CC(WD)} should never be below V_{CC}.

Test mode: HUS is HIGH except when the TAS detector is ON. If a thermal asperity is detected, HUS goes LOW.

Servo write mode: HUS is LOW.

Write mode:

- If in the configuration register d3 = 1, HUS is LOW
- If in the configuration register d3 = 0, HUS goes HIGH for:
 - Selection of a wrong head (H10 to H15)⁽¹⁾
 - R_{ext} pin open, short-circuited to ground or to V_{CC} (write current too low or too high)
 - Write Data Input frequency too low (WDIx-WDIy)
 - Write head Wx, Wy open, Wx or Wy short-circuited to ground⁽²⁾
 - Write driver still left biased while not selected
 - Low V_{CC} and V_{CC(WD)} conditions (write current inhibit can be active or inactive).

The same detector is used for read and write mode. The write current may be inhibited if d2 = 0 in the configuration register.

The HUS line indicates an unsafe condition as long as the fault is present, in read mode as well as in write mode. It indicates again a safe condition only 0.5 μs to 1 μs after the last fault has disappeared.

- (1) Head numbers 0 to 9 are correct, 10 to 15 are signalled as unsafe.
- (2) Switching to write mode makes HUS LOW. After the transient the HUS detection circuitry is activated. The target for the head open detection time is 15 ns.

8.9 HUS survey

HUS		DATA BIT D3	
MODE	STATE	0	1
Sleep mode	–	HIGH	HIGH
Standby mode	–	HIGH	HIGH
Active mode	Read	Read mode	ACTIVE
		A-test mode ⁽¹⁾	HIGH
		TAS mode	ACTIVE
	Write	Write mode	ACTIVE
		A-test mode ⁽¹⁾	HIGH
		Servo mode ⁽²⁾	LOW

Notes

1. A-test mode = analog test mode.
2. In servo mode, the performance of the IC is not guaranteed.

Pre-amplifier for Hard Disk Drive (HDD) with MR-read/inductive write heads

TDA5155

9 LIMITING VALUES

In accordance with the Absolute Maximum Rating System (IEC 134).

SYMBOL	PARAMETER	MIN.	MAX.	UNIT
V_{CC}	supply voltage	-0.5	+6.0	V
$V_{CC(WD)}$	write driver supply voltage	-0.5	+9.5	V
V_{n1}	voltage on all pins except $V_{CC(WD)}$, read inputs nRx, nRy and write driver outputs nWx, nWy (n = 0 to 9)	-0.5	+5.5	V
	absolute maximum value	-	$V_{CC} + 0.5$	V
V_{n2}	voltage on write driver outputs nWx, nWy	-0.5	+8.8	V
	absolute maximum value	-	$V_{CC(WD)} + 0.5$	V
V_{n3}	voltage on read inputs nRx, nRy	-0.5	+1	V
I_{nGND}	ground current (pins nGND)	-	0.1	A
T_{stg}	storage temperature	-65	+150	°C
T_j	junction temperature	-	150	°C

10 HANDLING

Inputs and outputs are protected against electrostatic discharge in normal handling. However, to be totally safe, it is desirable to take normal precautions appropriate to handling integrated circuits.

11 THERMAL CHARACTERISTICS

The thermal resistance depends on the flex used. The TDA5155X is shipped in naked dies form.

Pre-amplifier for Hard Disk Drive (HDD) with MR-read/inductive write heads

TDA5155

12 RECOMMENDED OPERATION CONDITIONS

SYMBOL	PARAMETER	CONDITIONS	MIN.	TYP	MAX.	UNIT
V _{CC}	supply voltage	note 1	4.5	–	5.5	V
V _{CC(WD)}	write driver supply voltage	note 2	V _{CC}	–	8.8	V
V _{IH}	HIGH level input voltage (CMOS)		3.5	–	V _{CC}	V
V _{IL}	LOW level input voltage (CMOS)		0	–	0.8	V
V _{i(dif)(p-p)}	differential input voltage (peak-to-peak value)	note 3	0.4	0.7	1.5	V
V _{IH(PECL)}	HIGH level PECL input voltage	note 3	–	2.85	V _{CC}	V
V _{IL(PECL)}	LOW level PECL input voltage	note 3	1.5	2.15	–	V
I _{i(dif)(p-p)}	differential input current (peak-to-peak value)	note 4	0.4	0.8	1.0	mA
I _{IH(dif)}	HIGH level differential input current	note 4	–1.4	–1.2	–	mA
I _{IL(dif)}	LOW level differential input current	note 4	–	–0.4	–0.1	mA
T _{amb}	ambient temperature		0	–	70	°C
T _j	junction temperature	reading	–	–	110	°C
		writing (V _{CC(WD)} = 8 V)	–	–	130	°C
R _{MR}	MR element resistance		15	28	34	Ω
Δ(R _{MR})	R _{MR} mismatch	note 5	–	–	4	Ω
L _{I(tot)}	total lead inductance to the head	in each lead; note 6	–	25	–	nH
R _{I(tot)}	total lead resistance to the head	in each lead; note 6	–	1.5	–	Ω
V _{MR}	voltage on top of MR elements	note 7	–	–	0.5	V
V _{sig(dif)(p-p)}	differential MR head input voltage (peak-to-peak value)		0.4	1	2	mV
L _{wh}	write head inductance	including lead; note 6	–	0.15	–	μH
R _{wh}	write head resistance	including lead; note 6	–	10	–	Ω
C _{wh}	write head capacitance	including lead; note 6	–	tbF	–	pF
R _{ext}	external reference resistor	$I_{ref} = \frac{V_{ref}}{R_{ext}}$	–	10	–	kΩ

Pre-amplifier for Hard Disk Drive (HDD) with MR-read/inductive write heads

TDA5155

Notes to the recommended operating conditions

1. A supply by-pass capacitor from V_{CC} to ground or a low pass filter may be used to optimize the PSRR.
2. The supply voltage $V_{CC(WD)}$ must never be below V_{CC} in normal mode, and two diode 1.4 V above V_{CC} in servo mode.
3. The given values should be interpreted in the way that the single ended voltage could swing from 0.2 to 0.75 V, and that the common mode voltage should be such that for any of the two states, the $V_{IH(PECL)}$ is less than V_{CC} and $V_{IL(PECL)}$ is more than 1.5 V.
PECL voltage swing: a wider peak-to-peak voltage swing can be used. In that case a current will flow through the WDI inputs. This current is approximately equal to $\frac{WDIx(v) - WDIy(v) - 1.4}{200}$
4. Same comments for the given values as for the voltage input mode. The HIGH (respectively LOW) level input current is defined such that it produces the same effect at the output of the writer (W_x , W_y) as the HIGH (resp. LOW) level input voltage.
5. The mismatch refers to the resistance of the two stripes of the same head. This is defined as follows:
 $\Delta(R_{MR}) = \text{abs}(R_{MR1} - R_{MR2})$.
6. These parameters depend on the head model. The data given in the table are those used for testing.
7. The combination of maximum head resistance, lead resistance and bias current is not permitted. To avoid voltage breakthrough between heads and disk, the voltage over the MR elements is limited by two diode voltages.

Pre-amplifier for Hard Disk Drive (HDD) with MR-read/inductive write heads

TDA5155

13 CHARACTERISTICS

$V_{CC} = 5.0\text{ V}$; $V_{CC(WD)} = 8\text{ V}$; $V_{GND} = 0\text{ V}$; $T_{amb} = 25\text{ °C}$; unless otherwise specified.

SYMBOL	PARAMETER	CONDITIONS	MIN.	TYP.	MAX.	UNIT
Read characteristics						
I_{MR}	MR current adjust range	$R_{ext} = 10\text{ k}\Omega$; 0.5 mA steps	5	–	20.5	mA
ΔI_{MR}	tolerance (excluding R_{ext})	I_{MR} programmed at 10 mA	–	± 4	–	%
$G_{V(dif)}$	differential voltage gain; note 1	from head inputs to RDx, RDy; $R_{MR} = 28\ \Omega$; $I_{MR} = 10\text{ mA}$; $f = 20\text{ MHz}$ $d4 = 0$ $d4 = 1$	–	160 226	–	
$R_{i(dif)}$	differential input resistance	$I_{MR} = 10\text{ mA}$	–	13	–	Ω
$C_{i(dif)}$	differential input capacitance		–	16	–	pF
THD	total harmonic distortion		–	1	–	%
B_L	lower signal gain pass-band edge	–3 dB	–	–	100	kHz
B_H	higher signal gain pass-band edge	–3 dB; note 2 without gain boost (4 nH lead inductance) with gain boost (50 nH lead inductance)	–	220 170	–	MHz MHz
F	noise figure	$R_{MR} = 28\ \Omega$; $I_{MR} = 10\text{ mA}$; $T_{amb} = 25\text{ °C}$; $f = 20\text{ MHz}$	–	3.0	3.2	dB
V_{irn}	input referred noise voltage; note 3	$R_{MR} = 28\ \Omega$; $I_{MR} = 10\text{ mA}$; $T_{amb} = 25\text{ °C}$; $f = 20\text{ MHz}$	–	0.9	1.0	nV/ $\sqrt{\text{Hz}}$
$B_{F(L)}$	lower noise band edge (+3 dB)	$R_{MR} = 28\ \Omega$; $I_{MR} = 10\text{ mA}$; $T_{amb} = 25\text{ °C}$; no lead inductance	–	–	400	kHz
$B_{F(H)}$	upper noise band edge (+3 dB)	$R_{MR} = 28\ \Omega$; $I_{MR} = 10\text{ mA}$; $T_{amb} = 25\text{ °C}$; no lead inductance	–	220	–	MHz
α_{cs}	channel separation; note 4	unselected head	–	50	–	dB
PSRR	power supply rejection ratio; note 5	$f < 1\text{ MHz}$; $I_{MR} = 10\text{ mA}$	–	80	–	dB
		$f < 100\text{ MHz}$; $I_{MR} = 10\text{ mA}$	–	50	–	dB
CMRR	common mode rejection ratio; note 5	from nRx-nRy to RDx-RDy R_{MR} mismatch $< 5\%$ $I_{MR} = 10\text{ mA}$	–	45	–	dB
		$f < 1\text{ MHz}$	–	25	–	dB
		$f < 100\text{ MHz}$	–	–	–	–

Pre-amplifier for Hard Disk Drive (HDD) with MR-read/inductive write heads

TDA5155

SYMBOL	PARAMETER	CONDITIONS	MIN.	TYP.	MAX.	UNIT
DR	rejection ratio of SCLK and SDATA; note 6	from SCLK, SDATA inputs to the RDx-RDy outputs; a 200 mV (peak-to-peak) signal is applied to SCLK or SDATA inputs at 25 MHz, and measurement is performed at RDx-RDy	–	50	–	dB
$V_{O(R)(dif)}$	output DC offset voltage in read mode (differential after DC settling)	DC voltage between RDx and RDy	–	–	±0.2	V
$Z_{O(R)}$	output impedance in read mode	single ended	–	16	–	Ω
$I_{O(max)(dif)}$	maximum differential output current		–	4	–	mA
$V_{O(cm)}$	common mode output voltage in read mode	RDx, RDy	1.0	1.5	2.0	V
$\frac{\Delta V_{O(cm)}}{\Delta V_{CC}}$	common mode DC supply rejection ratio in read mode		–	20	–	dB
$Z_{O(n)(dif)}$	differential output impedance in other modes (write, standby, sleep)		–	50	–	kΩ
Write characteristics						
I_{WR}	write current adjust range (in the write drivers)	$R_{ext} = 10\text{ k}\Omega$; 1 mA steps	20	35	51	mA
ΔI_{WR}	tolerance (excluding R_{ext})	I_{WR} programmed at 35 mA	–	±7	–	%
$V_{S(max)(p-p)}$	maximum voltage swing (peak-to-peak value)	$V_{CC(WD)} = 5\text{ V}$	–	–	8	V
		$V_{CC(WD)} = 8\text{ V (differential)}$	–	–	13	V
$R_{O(dif)}$	differential output resistance		–	200	–	Ω
$C_{O(dif)}$	differential output capacitance	not including the head capacitance	–	5	–	pF
t_r, t_f	write current rise/fall time without flip-flop (10% to 90%); note 7	$L_h = 150\text{ nH}$; $R_h = 10\ \Omega$; $I_{WR} = 35\text{ mA}$; $f = 20\text{ MHz}$	–	–	1.8	ns
		$V_{CC(WD)} = 8.0\text{ V}$	–	–	2.1	ns
		$V_{CC(WD)} = 6.5\text{ V}$	–	–	–	–
t_{as}	write current rise/fall time asymmetry; note 8	percentage of t_r or t_f (t_r or t_f and logic asymmetry)	–	–	5	%
t_{pd}	propagation delay 50% of (WDIx/WDIy) to 50% of (Wx, Wy)	write head short-circuited, data flip-flop by-passed	–	–	5	ns
α_{cs}	channel separation	not-selected head	–	45	–	dB

Pre-amplifier for Hard Disk Drive (HDD) with MR-read/inductive write heads

TDA5155

SYMBOL	PARAMETER	CONDITIONS	MIN.	TYP.	MAX.	UNIT
Switching characteristics						
f _{SCLK}	serial interface clock rate		–	–	25	MHz
ΔV _{o(cm)}	common mode DC output voltage change from read to write mode	I _{MR} = 10 mA; I _{WR} = 35 mA	–	200	–	mV
t _{rec(W-R)}	write-to-read recovery time (AC and DC settling); note 9	from 50% of the rising edge of R/W to steady state read-back signal: AC and DC settling at 90% (without load at RDx, RDy) read amplifier OFF: d5 = 0 read amplifier ON: d5 = 1	–	3	4.5	μs
t _{sw(R)}	head switching (in read mode), standby to read active and MR current change recovery time. (AC and DC settling); note 10	from falling edge of SEN to steady state read-back signal (without load at RDx, RDy)	–	3	4.5	μs
t _{off(R)}	read amplifier off time	from falling edge of R/W to read head inactive	–	–	50	ns
t _{st(W)}	write settling times; note 11	from 50% of the falling edge of R/W to 90% of the steady state write current (in write mode)	–	–	70	ns
t _{off(W)}	write amplifier off time	from rising edge of R/W to 1/10 × I _{WR} (programmed) (I _{WR} = 35 mA)	–	–	50	ns
t _{sw(W)}	head switching (in write mode), and standby to write head active	from falling edge of SEN to write head active	–	50	70	ns
t _{sw(S)}	switch time to and from sleep mode		–	–	100	μs
DC characteristics						
I _{CC(R)}	read mode supply current	I _{MR} = 10 mA; note 12	–	72	80	mA
I _{CC(W)}	write mode supply current	I _{WR} = 35 mA; note 13 from V _{CC} (5 V) from V _{CC(WD)} (5 to 8 V)	–	33	41	mA
I _{DD(STB)}	standby mode supply current		–	0.25	1	mA
I _{DD(S)}	sleep mode supply current	static	–	–0.02	–	mA
V _{ref}	reference voltage for R _{ext}		–	1.32	–	V

Pre-amplifier for Hard Disk Drive (HDD) with MR-read/inductive write heads

TDA5155

Notes to the characteristics

- The differential voltage gain depends on the MR resistance. It can be improved by programming the d4 bit in the configuration register.
- The gain boost implements a pole-zero combination: The +3 dB gain boost corner frequency is $\frac{800 \text{ MHz}}{8.d3 + 4.d2 + 2.d1 + 1.d0}$. The -3 dB gain attenuation corner frequency is $\frac{800 \text{ MHz}}{8.d3 + 4.d2 + 2.d1 + 1.d0}$, where d3, d2, d1 and d0 are to be programmed via the serial interface. In practical use, the bandwidth is limited by the inductance of the connection between the MR heads and the pre-amplifier.
- Noise calculation**
 - Definitions:** The amplifier has a low input resistance. No lead resistance is taken into account. The input referred noise voltage, excluding the noise of the MR resistors, is defined as: $(V_{im})^2 = \left[\frac{V_{no}}{G_v} \right]^2 - 4kT \times (R_{MR1} + R_{MR2})$, where G_v is the voltage gain, V_{no} is the noise voltage at the output of the amplifier, k is the Boltzmann constant and T is the temperature in K. The noise figure is defined as follows:

$$F = 10 \times \log \left(\frac{\left[\frac{V_{no}}{G_v} \right]^2}{4kT \times (R_{MR1} + R_{MR2})} \right) \text{ in 1 Hz}$$
 bandwidth. Note that R_{MR} includes all resistances between Rx or Ry to ground.
 - Noise figure versus I_{MR} and R_{MR} :** Table 1 shows the variation of the noise figure with I_{MR} and R_{MR} .
 - Input referred noise voltage:** The input referred noise voltage calculation can be significantly different (from 1.0 to 0.44 nV/ $\sqrt{\text{Hz}}$ for instance) by taking an equivalent signal-to-noise ratio into account when using two MR stripes (28 Ω for each stripe) or one MR stripe (42 Ω). It assumes that the signal coming from the head is larger for a dual-stripe head than for a single-stripe head (50% extra signal for a dual-stripe head).
- The channel separation is defined by the ratio of the gain response of the amplifier using the selected head $H(n)$ to the gain response of the amplifier using the adjacent head $H(n \pm 1)$, head $H(n)$ being selected.

- The PSRR (in dB) is defined as input referred ratio: $\text{PSRR} = 20 \times \log \frac{G_v}{G_p}$, where G_v is the differential input to differential output gain, and G_p is the power supply to differential output gain. The CMRR (in dB) is defined as input referred ratio: $\text{CMRR} = 20 \times \log \frac{G_v}{G_{cm}}$, where G_v is the differential input to differential output gain and G_{cm} is the common mode input to differential output gain. Flex and board lay-out may affect these parameters significantly.
- This refers to the crosstalk from SCLK and SDATA inputs via the read inputs to RDx and RDy. Two cases can be distinguished:
 - When SEN is LOW, SCLK and SDATA are prohibited reaching the device and crosstalk is low.
 - Programming via the serial interface is done with SEN HIGH. Then crosstalk can occur. A careful design of the board or flex-foil is required to avoid crosstalk via this path.
- The rise and fall times depend on the write amplifier/write head combination. L_h and R_h represent the components on the evaluation board. Parasitic capacitances also limit the performance.
- The write current rise/fall time asymmetry is defined by $\frac{|t_r - t_f|}{2(t_r + t_f)}$
- Write-to-read recovery time includes the write mode to read mode switching using the R/W pin on the same head (see Fig.5). The AC signal reaches its full amplitude few tens of ns after appearing at the reader RDx and RDy outputs.
- In read mode, the head switching, standby to read active switching and changing MR current include fast current settling (see Fig.5). The AC signal reaches its full amplitude few tenth of ns after appearing at the reader RDx and RDy outputs.
- Write settling time includes the read mode to write mode switching using the R/W pin.
- The typical supply current in read mode depends on the bias current for the MR element.
- The typical supply current in write mode also depends on the write current.

Pre-amplifier for Hard Disk Drive (HDD)
with MR-read/inductive write heads

TDA5155

Table 1 Noise figure

$R_{MR} (\Omega)$	F (dB)		
	$I_{MR} = 7 \text{ mA}$	$I_{MR} = 10 \text{ mA}$	$I_{MR} = 15 \text{ mA}$
20	2.7	2.9	3.1
25	2.8	3.0	3.3
30	2.9	3.1	3.5

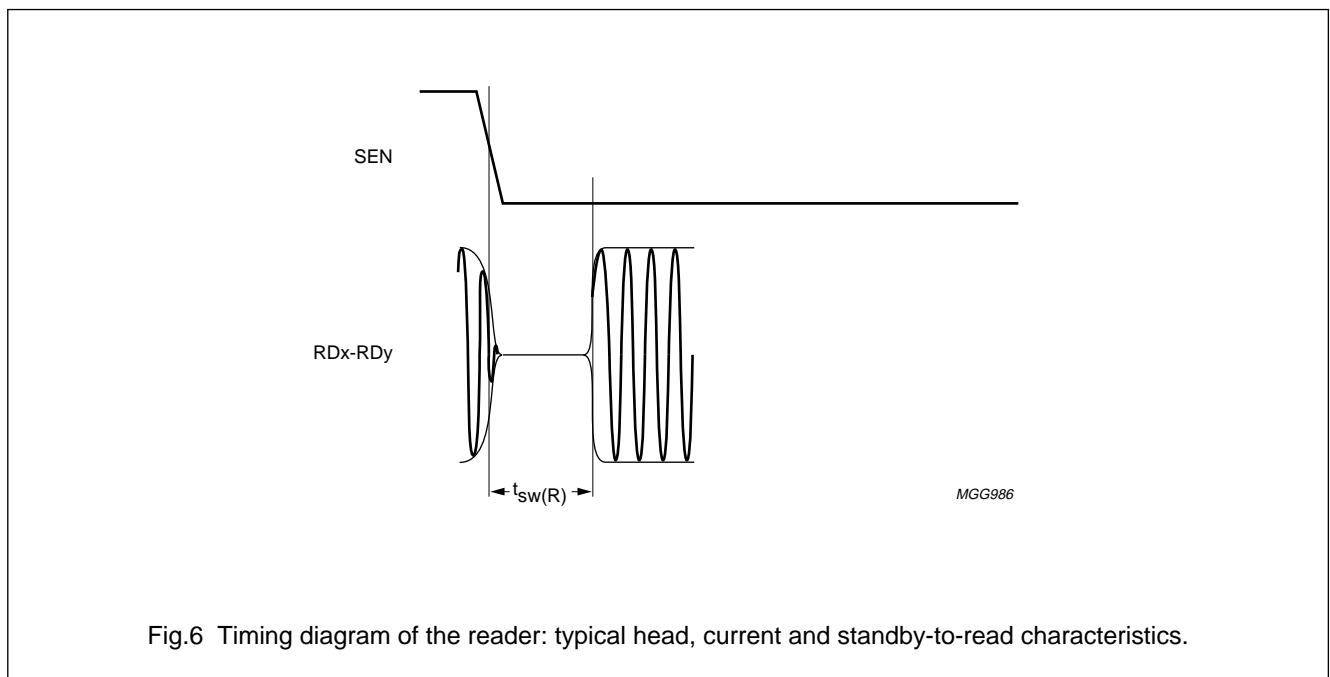
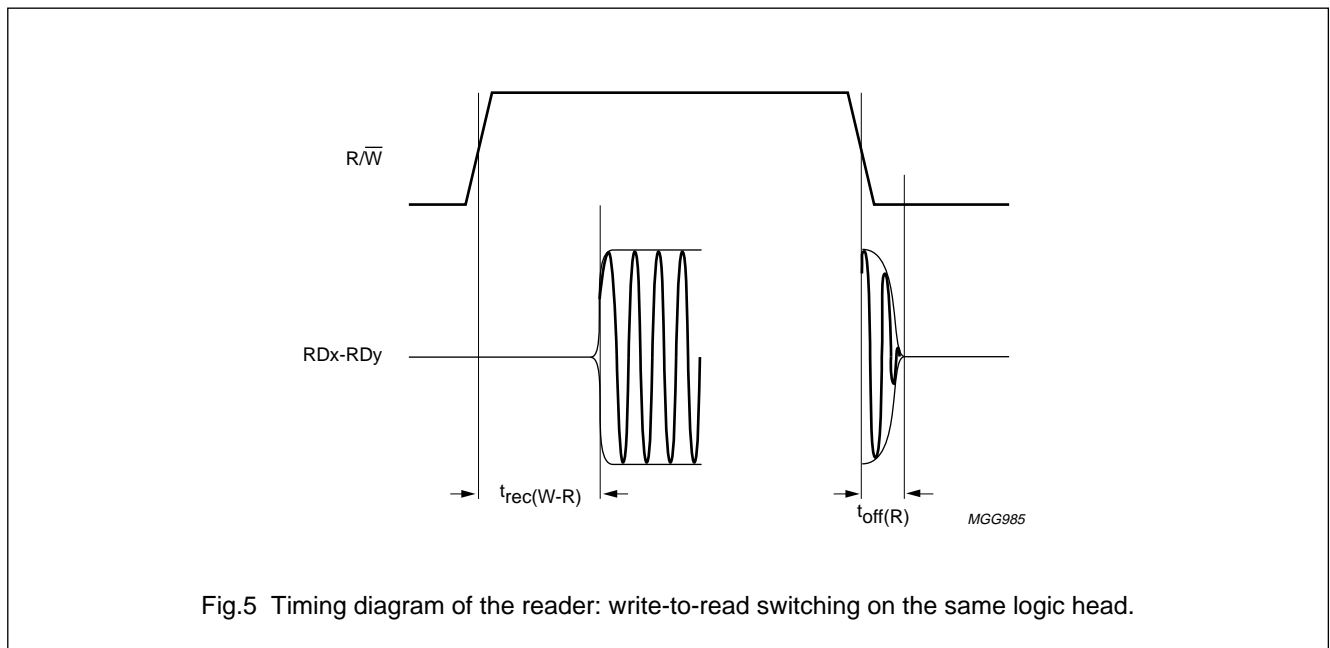

Pre-amplifier for Hard Disk Drive (HDD) with MR-read/inductive write heads

TDA5155

14 DEFINITIONS

Data sheet status	
Objective specification	This data sheet contains target or goal specifications for product development.
Preliminary specification	This data sheet contains preliminary data; supplementary data may be published later.
Product specification	This data sheet contains final product specifications.
Limiting values	
Limiting values given are in accordance with the Absolute Maximum Rating System (IEC 134). Stress above one or more of the limiting values may cause permanent damage to the device. These are stress ratings only and operation of the device at these or at any other conditions above those given in the Characteristics sections of the specification is not implied. Exposure to limiting values for extended periods may affect device reliability.	
Application information	
Where application information is given, it is advisory and does not form part of the specification.	

15 LIFE SUPPORT APPLICATIONS

These products are not designed for use in life support appliances, devices, or systems where malfunction of these products can reasonably be expected to result in personal injury. Philips customers using or selling these products for use in such applications do so at their own risk and agree to fully indemnify Philips for any damages resulting from such improper use or sale.

Philips Semiconductors – a worldwide company

Argentina: see South America

Australia: 34 Waterloo Road, NORTH RYDE, NSW 2113,
Tel. +61 2 9805 4455, Fax. +61 2 9805 4466

Austria: Computerstr. 6, A-1101 WIEN, P.O. Box 213,
Tel. +43 1 60 101, Fax. +43 1 60 101 1210

Belarus: Hotel Minsk Business Center, Bld. 3, r. 1211, Volodarski Str. 6,
220050 MINSK, Tel. +375 172 200 733, Fax. +375 172 200 773

Belgium: see The Netherlands

Brazil: see South America

Bulgaria: Philips Bulgaria Ltd., Energoproject, 15th floor,
51 James Bourchier Blvd., 1407 SOFIA,
Tel. +359 2 689 211, Fax. +359 2 689 102

Canada: PHILIPS SEMICONDUCTORS/COMPONENTS,
Tel. +1 800 234 7381

China/Hong Kong: 501 Hong Kong Industrial Technology Centre,
72 Tat Chee Avenue, Kowloon Tong, HONG KONG,
Tel. +852 2319 7888, Fax. +852 2319 7700

Colombia: see South America

Czech Republic: see Austria

Denmark: Prags Boulevard 80, PB 1919, DK-2300 COPENHAGEN S,
Tel. +45 32 88 2636, Fax. +45 31 57 0044

Finland: Sinikalliontie 3, FIN-02630 ESPOO,
Tel. +358 9 615800, Fax. +358 9 61580920

France: 4 Rue du Port-aux-Vins, BP317, 92156 SURESNES Cedex,
Tel. +33 1 40 99 6161, Fax. +33 1 40 99 6427

Germany: Hammerbrookstraße 69, D-20097 HAMBURG,
Tel. +49 40 23 53 60, Fax. +49 40 23 536 300

Greece: No. 15, 25th March Street, GR 17778 TAVROS/ATHENS,
Tel. +30 1 4894 339/239, Fax. +30 1 4814 240

Hungary: see Austria

India: Philips INDIA Ltd, Shivsagar Estate, A Block, Dr. Annie Besant Rd.
Worli, MUMBAI 400 018, Tel. +91 22 4938 541, Fax. +91 22 4938 722

Indonesia: see Singapore

Ireland: Newstead, Clonskeagh, DUBLIN 14,
Tel. +353 1 7640 000, Fax. +353 1 7640 200

Israel: RAPAC Electronics, 7 Kehilat Saloniki St, PO Box 18053,
TEL AVIV 61180, Tel. +972 3 645 0444, Fax. +972 3 649 1007

Italy: PHILIPS SEMICONDUCTORS, Piazza IV Novembre 3,
20124 MILANO, Tel. +39 2 6752 2531, Fax. +39 2 6752 2557

Japan: Philips Bldg 13-37, Kohnan 2-chome, Minato-ku, TOKYO 108,
Tel. +81 3 3740 5130, Fax. +81 3 3740 5077

Korea: Philips House, 260-199 Itaewon-dong, Yongsan-ku, SEOUL,
Tel. +82 2 709 1412, Fax. +82 2 709 1415

Malaysia: No. 76 Jalan Universiti, 46200 PETALING JAYA, SELANGOR,
Tel. +60 3 750 5214, Fax. +60 3 757 4880

Mexico: 5900 Gateway East, Suite 200, EL PASO, TEXAS 79905,
Tel. +9-5 800 234 7381

Middle East: see Italy

Netherlands: Postbus 90050, 5600 PB EINDHOVEN, Bldg. VB,
Tel. +31 40 27 82785, Fax. +31 40 27 88399

New Zealand: 2 Wagener Place, C.P.O. Box 1041, AUCKLAND,
Tel. +64 9 849 4160, Fax. +64 9 849 7811

Norway: Box 1, Manglerud 0612, OSLO,
Tel. +47 22 74 8000, Fax. +47 22 74 8341

Philippines: Philips Semiconductors Philippines Inc.,
106 Valero St. Salcedo Village, P.O. Box 2108 MCC, MAKATI,
Metro MANILA, Tel. +63 2 816 6380, Fax. +63 2 817 3474

Poland: Ul. Lukiska 10, PL 04-123 WARSZAWA,
Tel. +48 22 612 2831, Fax. +48 22 612 2327

Portugal: see Spain

Romania: see Italy

Russia: Philips Russia, Ul. Usatcheva 35A, 119048 MOSCOW,
Tel. +7 095 755 6918, Fax. +7 095 755 6919

Singapore: Lorong 1, Toa Payoh, SINGAPORE 1231,
Tel. +65 350 2538, Fax. +65 251 6500

Slovakia: see Austria

Slovenia: see Italy

South Africa: S.A. PHILIPS Pty Ltd., 195-215 Main Road Martindale,
2092 JOHANNESBURG, P.O. Box 7430 Johannesburg 2000,
Tel. +27 11 470 5911, Fax. +27 11 470 5494

South America: Rua do Rocio 220, 5th floor, Suite 51,
04552-903 São Paulo, SÃO PAULO - SP, Brazil,
Tel. +55 11 821 2333, Fax. +55 11 829 1849

Spain: Balmes 22, 08007 BARCELONA,
Tel. +34 3 301 6312, Fax. +34 3 301 4107

Sweden: Kottbygatan 7, Akalla, S-16485 STOCKHOLM,
Tel. +46 8 632 2000, Fax. +46 8 632 2745

Switzerland: Allmendstrasse 140, CH-8027 ZÜRICH,
Tel. +41 1 488 2686, Fax. +41 1 481 7730

Taiwan: Philips Semiconductors, 6F, No. 96, Chien Kuo N. Rd., Sec. 1,
TAIPEI, Taiwan Tel. +886 2 2134 2865, Fax. +886 2 2134 2874

Thailand: PHILIPS ELECTRONICS (THAILAND) Ltd.,
209/2 Sanpavuth-Bangna Road Prakanong, BANGKOK 10260,
Tel. +66 2 745 4090, Fax. +66 2 398 0793

Turkey: Talatpasa Cad. No. 5, 80640 GÜLTEPE/ISTANBUL,
Tel. +90 212 279 2770, Fax. +90 212 282 6707

Ukraine: PHILIPS UKRAINE, 4 Patrice Lumumba str., Building B, Floor 7,
252042 KIEV, Tel. +380 44 264 2776, Fax. +380 44 268 0461

United Kingdom: Philips Semiconductors Ltd., 276 Bath Road, Hayes,
MIDDLESEX UB3 5BX, Tel. +44 181 730 5000, Fax. +44 181 754 8421

United States: 811 East Arques Avenue, SUNNYVALE, CA 94088-3409,
Tel. +1 800 234 7381

Uruguay: see South America

Vietnam: see Singapore

Yugoslavia: PHILIPS, Trg N. Pasica 5/v, 11000 BEOGRAD,
Tel. +381 11 625 344, Fax. +381 11 635 777

For all other countries apply to: Philips Semiconductors, Marketing & Sales Communications,
Building BE-p, P.O. Box 218, 5600 MD EINDHOVEN, The Netherlands, Fax. +31 40 27 24825

Internet: <http://www.semiconductors.philips.com>

© Philips Electronics N.V. 1997

SCA54

All rights are reserved. Reproduction in whole or in part is prohibited without the prior written consent of the copyright owner.

The information presented in this document does not form part of any quotation or contract, is believed to be accurate and reliable and may be changed without notice. No liability will be accepted by the publisher for any consequence of its use. Publication thereof does not convey nor imply any license under patent- or other industrial or intellectual property rights.

Printed in The Netherlands

297027/20/01/pp24

Date of release: 1997 Apr 08

Document order number: 9397 750 01427

Let's make things better.

**Philips
Semiconductors**



PHILIPS