

T-77-07-07

TV-Stereo Processor

TDA 6610-2

Bipolar IC

Features

- All functions are I²C-bus controlled
- Suitable for multistandard including NICAM SCART-interface
- Independent headphones output high signal noise ratio
- Extremely low total harmonic distortion
- High security of detection of the stereo decoder part because of the digital interference suppression and the very narrow bandwidth

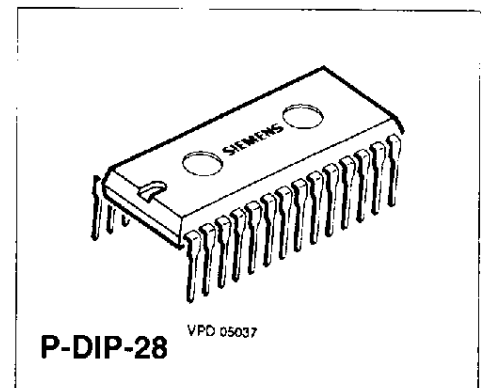

Type	Ordering Code	Package
TDA 6610-2	Q67000-A5026	P-DIP-28

General

The TDA 6610-2 represents a complete TV-stereo sound system controlled via the I²C-bus. The IC is divided into three functional blocks:

1. **Stereo Sound Processing with High Quality (exceeds DIN 45500; suitable for NICAM and CD)**
 - a) Matrix for G-standard
 - b) Additional single-channel AF-input (for e.g. AF-signal according to L-standard)
 - c) Stereo SCART-interface is in accordance with FTZ-official specification
 - d) Stereo loudspeaker signal section with Ch1/Ch2 switch, treble/bass control, quasi-stereo/ stereo base width control and separate left/right loudspeaker volume control
 - e) Signal section with Ch1/Ch2 switch and volume control for stereo headphones

2. TV-Sound Identification Signal Decoder Consisting of:

- a) Active pilot signal filter
- b) Phase-independent rectifier with very narrow bandwidth for evaluation of the identification signal
- c) Digital integrator to reduce interference
- d) Multiplexer for cyclical switch over between "stereo" or "dual" recognition
- e) PLL for the generation of the reference signal. External synchronization with either the fly-back pulse or external reference clock signals of 62.5 kHz

3. Control Section for:

- a) I²C-bus interface with listen/talk function
- b) Control of the complete AF-sound processing
- c) Control of the identification signal decoder
- d) Reading of the identification signal decoder status
- e) Test modes

SIEMENS AKTIENGESELLSCHAFT

Pin Functions

Pin No.	Function
1	AF-input mono, left, sound 1
2	Bias for AF-unit
3	AF-input right, sound 2
4	54-kHz input
5	54-kHz filter
6	AF-input (L-standard)
7	AF-input SCART left (sound 1)
8	AF-input SCART right (sound 2)
9	AF-output SCART (mono, sound 1, left)
10	AF-output SCART (mono, sound 2, right)
11	Phase-shifter quasi-stereo
12	Phase-shifter quasi-stereo
13	Cutoff frequency base (base-width) left
14	Cutoff frequency base (base-width) right
15	AF-output, loudspeaker left
16	AF-output, loudspeaker right
17	Cutoff frequency treble left
18	Cutoff frequency treble right
19	AF-output, headphones left
20	AF-output, headphones right
21	+ V_s (supply voltage)
22	I ² C-bus SCL
23	I ² C-bus SDA
24	Input H-pulse (4 x H-pulse)
25	Filter ID-signal decoder
26	Filter ID-signal decoder
27	PLL-filter ID-signal decoder
28	Ground

SIEMENS AKTIENGESELLSCHAFT

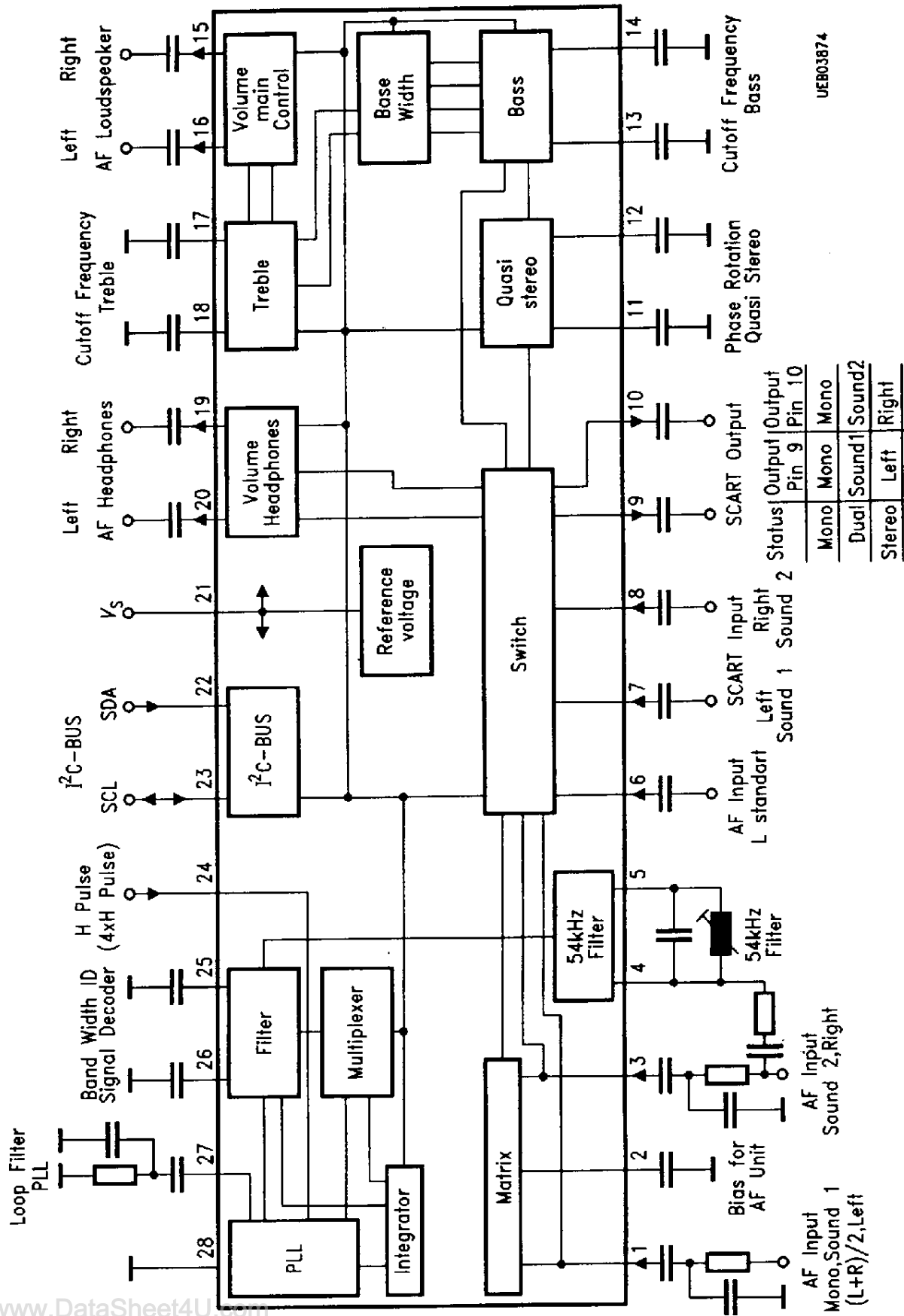

UEB03874

Block Diagram

Circuit Description

Signal Section

The audio signal processing in the matrix and the switch-over for multichannel TV-sound signals according to the two-carrier system used in Germany takes place in the matrix and switching sections. In addition to the two inputs for the demodulated sound carrier a two-channel SCART-input and an additional mono input (e.g. for demodulated L-standard sound) are provided. The two AF-inputs can be by-passed internally in such a way that decoded stereo sound signals of other audio systems (NICAM) can be processed. The switching section is terminated with the SCART-output and an independently switchable Ch1/Ch2 switch for the loudspeaker and headphone outputs.

In the loudspeaker signal path a switchable quasi-stereo section follows the Ch1/Ch2 switch. This section gives a special audio effect with mono signals due to a 180° phase shift at medium frequencies (about 1 kHz) in one channel. The following bass control exhibits a step of 3 dB with an adjustment range of + 15/- 12 dB. The cutoff frequency is set for each channel with an external capacitor.

A circuit for stereo base-width expansion, switchable if stereo signals are recognized, provides a more spatial audio effect due to 50 % of frequency dependent crosstalk in opposing phases. The circuit operates with the same cutoff frequency as the bass control, but the function is largely independent. Likewise the treble control, whose cutoff frequency is also controlled by a capacitor in each channel, has a step of 3 dB with an adjustment range of ± 12 dB. The volume control can be adjusted independently for the right and left loudspeaker signal path. Using 57 steps of 1.25 dB each, a 70 dB adjustment range is available, where the 57th step activates the "MUTE" function. Functions such as "balance" or "loudness" are realized by software adjustment of the appropriate tone and volume controls.

In the signal path for the headphones after the Ch1/Ch2 switch a volume control circuit is used for the simultaneous left/right adjustment. Thirty-two steps of 2 dB each allow an adjustment range of 62 dB (31 x 2 dB = 62 dB, while the 32nd step activates the "MUTE" function).

Identification Sound Decoder

The input of the identification sound decoder consists of an op-amp for the pilot signal with its sidebands. An external LC-circuit is used to select the pilot carrier and his sidebands. The signal is then passed to a phase-independent active band-pass filter with a very narrow bandwidth (adjustable externally). This filter detects whether the lower side-band of the pilot carrier, modulated with the identification signal, is present. The center frequency of the filter is switched between "dual" and "stereo" by a multiplexer. The multiplexing frequency is adjustable by software. If a side-band is detected, the multiplexer stops. The first "detected" criterion is processed by a digital integrator and a following comparator in order to suppress interferences due to noise. The decoder status can be read out via I²C-bus (talk mode) as the "stereo" or "dual" mode. The control of the corresponding signal path can take place either directly internally or through the μ C. All required clock signals are derived from a fast locking PLL synchronized by an external reference frequency. This reference frequency has to be sufficiently close to the horizontal frequency, but **a rigid phase coupling is not required**. Therefore, alternatively to the line frequency the use of a crystal-controlled 62.5 kHz frequency commonly available in PLL tuning systems is possible.

– SIEMENS AKTIENGESELLSCHAFT

Control Section

All functions are controlled via I²C-bus interface with listen/talk functions. The actual valid data are stored in a latch block.

The telegram structure is:

start condition - chip address - any number of data bytes - stop condition

The following conditions apply to the data bytes:

Before a data byte (with the adjustment information) is transmitted, a subaddress byte has **always** to be transmitted.

Example: The headphone volume (HP vol) has to be increased in several (i.e. 3) steps.

Right		Wrong	
Start condition		Start condition	
Chip address	84 (Hex)	Chip address	84 (Hex)
Subaddr. vol	03 (Hex)	Subaddr. vol	03 (Hex)
Volume step 8	08 (Hex)	Volume step 8	08 (Hex)
Subaddr. vol	03 (Hex)	Volume step 9	09 (Hex)
Volume step 9	09 (Hex)	Volume step 10	0A (Hex)
Subaddr. vol	03 (Hex)	Stop condition	
Volume step 10	0A (Hex)		
Stop condition			

Within a telegram (i.e. without a new start condition) any different subaddresses can be accessed. The changeover between "listen" and "talk" however has always to be initialized via the sequence "stop condition - start condition - chip address". Before each readout always a start condition and chip address (talk) has to be transmitted. The data to be read out are loaded into the I²C-bus interface after this sequence and are available for the transfer to the μ C.

Chip Address

MSB	•	•	•	•	•	•	LSB
1	0	0	0	0	1	0	R/W

R/W = 0 → Read (Listen)

R/W = 1 → Write (Talk)

SIEMENS AKTIENGESELLSCHAFT

Subaddress Bytes

	MSB	•	•	•	•	•	•	LSB
Loudspeaker volume left	X	X	X	X	X	0	0	1
Loudspeaker volume right	X	X	X	X	X	0	1	0
Headphone volume	X	X	X	X	X	0	1	1
Treble/bass	X	X	X	X	X	1	0	1
Switch byte I	X	X	X	X	X	1	1	1
Switch byte II	X	X	X	X	X	0	0	0

Setting Bytes

a) Loudspeaker Volume Left / Right

	MSB	•	•	•	•	•	•	LSB
Maximum volume	X	X	1	1	1	1	1	1
Max – 1 step	X	X	1	1	1	1	1	0
Max – 15 steps	X	X	1	1	0	0	0	0
Max – 55 steps	X	X	0	0	1	0	0	0
MUTE	X	X	0	0	0	1	1	1
MUTE	X	X	0	0	0	0	0	0
MUTE	X	X	0	0	0	X	X	X
Power ON	0	0	0	0	0	0	0	1

b) Headphone Volume

	MSB	•	•	•	•	•	•	LSB
Max. volume	T2	T1	T0	1	1	1	1	1
Max – 1 step	T2	T1	T0	1	1	1	1	0
Max – 15 steps	T2	T1	T0	1	0	0	0	0
Max – 31 steps	T2	T1	T0	0	0	0	0	1
MUTE	T2	T1	T0	0	0	0	0	0
Power ON	0	0	0	0	0	0	0	1

T0 - T2 are test bits; these have to be set to 0 for normal operation.

SIEMENS AKTIENGESELLSCHAFT

c) Treble / Bass

	MSB	•	•	•	•	•	•	LSB
Linear	1	0	0	0	1	0	0	0
Max. treble, lin. bass	1	1	0	0	1	0	0	0
Max. treble, lin. bass	1	1	X	X	1	0	0	0
Min. treble, lin. bass	0	1	0	0	1	0	0	0
Min. treble, lin. bass	0	0	X	X	1	0	0	0
Lin. treble, max. bass	1	0	0	0	1	1	0	1
Lin. treble, max. bass	1	0	0	0	1	1	X	1
Lin. treble, max. bass	1	0	0	0	1	1	1	X
Lin. treble, min. bass	1	0	0	0	0	1	0	0
Lin. treble, min. bass	1	0	0	0	0	0	X	X
Max. treble, max. bass	1	1	X	X	1	1	X	1
Min. treble, min. bass	0	0	X	X	0	0	X	X
Power ON	0	0	0	0	0	0	0	1
	MSB				LSB	MSB		LSB
	treble				treble	bass		bass

SIEMENS AKTIENGESELLSCHAFT

d) Switch Byte I

MSB	LSB
MUTE I	MUTE II	Ch1/Ch2 _{vol}	Ch1/Ch2 _{HP}	Mono	SCART	SCART-D	AM
MUTE I = 0	All AF-outputs are muted (loudspeakers, headphones, SCART); power ON						
MUTE I = 1	All AF-outputs ON						
MUTE II = 0	Loudspeaker outputs muted; power ON						
MUTE II = 1	Loudspeaker outputs ON						
MUTE I and MUTE II are OR gated with respect to the loudspeaker outputs							

MUTE I	MUTE II	Loudspeaker outputs	Headphones, SCART-outputs
0	0	muted	muted
0	1	muted	muted
1	0	muted	ON
1	1	ON	ON

CH1/Ch2_{vol} = 0 Sound 1 on the loudspeaker outputs; power ON

CH1/Ch2_{vol} = 1 Sound 2 on the loudspeaker outputs

CH1/Ch2_{HP} = 0 Sound 1 on the headphone outputs; power ON

CH1/Ch2_{HP} = 1 Sound 2 on the headphone outputs

CH1/Ch2_{vol} and CH1/Ch2_{HP} are only effective if the matrix is set to the position "dual sound".

Mono = 0 identification signal decoder is set to mono position and held; power ON

Mono = 1 normal operation of identification signal decoder

SCART = 0 normal TV-operation; power ON

SCART = 1 SCART-playback; connection of SCART-inputs - AF-outputs. SCART = 1 has priority over AM = 1 (loudspeaker and headphones)

SCART-D = 0 SCART-playback stereo (mono); power ON

SCART-D = 1 Enable for the Ch1/Ch2 switch during SCART-playback (only effective when SCART = 1)

Standard L = 0 normal operation (G-standard)

Standard L = 1 AM AF-input is activated; power ON
AM = 1 has priority over bypass = 1

e) Switch Byte II

MSB							•	LSB						
MPX0	MPX1	Quasi-st	Be	H-pul	Matrix 0	Matrix 1	Bypass							
MPX0	MPX 1	MPX period					recommended $C_{25, 26}$							
0	0	2 s		power ON		1 μ F								
0	1	4 s				2.2 μ F								
1	0	8 s				4.7 μ F								
1	1	1 s				470 nF								

MPX-period = 2 s signifies: Identification (ID) signal decoder searches 1 s for dual and 1 s for stereo transmission

Quasi-st = 0 Quasi-stereo OFF; Power ON
 Quasi-St = 1 Quasi-stereo ON
 Be = 0 Stereo basewidth expansion OFF; Power ON
 Be = 1 Stereo basewidth expansion ON

H pul = 0 ID-signal decoder synchronization with $f_H = 15.625$ kHz; power ON
 H pul = 1 ID-synchronization with $4 \times f_H$

Matrix 0 Matrix 1 Matrix status
 0 0 mono power ON
 0 1 stereo
 1 0 dual
 1 1 automatic according to ID-signal decoder

Bypass = 0 Normal operations (G-standard)
 Bypass = 1 Matrix is bridged so that left/right signals can be fed in; power ON
 (AM = 1 has priority over bypass = 1)

SIEMENS AKTIENGESELLSCHAFT

Priority List of Setting Bits

1. MUTE I
2. MUTE II (only with regard to the loudspeaker outputs)
3. SCART
4. Standard L
5. Bypass
6. Matrix 0, 1

h) Talk Mode

MSB	•	•	•	•	•	•	LSB
St	D	T5	T4	T3	X	X	X
0	0	decoder detects mono					
1	0	decoder detects stereo					
0	1	decoder detects dual					
1	1	internally inhibited					

T3 - T5 are test bits

SIEMENS AKTIENGESELLSCHAFT

Absolute Maximum Ratings

$T_A = 0$ to 70 °C; all voltages relatives to V_{SS}

Parameter	Symbol	Limit Values		Unit	Remarks
		min.	max.		
Supply voltage	V_{21}	0	14	V	
Max. DC-voltage	V_1	0	V_{21}	V	
Max. DC-voltage	V_2	0	V_{21}	V	
Max. DC-voltage	V_3	0	V_{21}	V	
Max. DC-voltage	V_4	0	V_{21}	V	
Max. DC-voltage	V_6	0	V_{21}	V	
Max. DC-voltage	V_7	0	V_{21}	V	
Max. DC-voltage	V_8	0	V_{21}	V	
Max. DC-voltage	V_{11}	0	V_{21}	V	
Max. DC-voltage	V_{12}	0	V_{21}	V	
Max. DC-voltage	V_{13}	0	V_{21}	V	
Max. DC-voltage	V_{14}	0	V_{21}	V	
Max. DC-voltage	V_{17}	0	V_{21}	V	
Max. DC-voltage	V_{18}	0	V_{21}	V	
Max. DC-voltage	V_{22}	0	V_{21}	V	
Max. DC-voltage	V_{23}	0	V_{21}	V	
Max. DC-voltage	V_{24}	0	V_{21}	V	
Max. DC-voltage	V_{25}	0	V_{21}	V	
Max. DC-voltage	V_{26}	0	V_{21}	V	
Max. DC-current	I_5	0	2	mA	
Max. DC-current	I_9	0	2	mA	
Max. DC-current	I_{10}	0	2	mA	
Max. DC-current	I_{15}	0	2	mA	
Max. DC-current	I_{16}	0	2	mA	
Max. DC-current	I_{19}	0	2	mA	
Max. DC-current	I_{20}	0	2	mA	
Max. DC-current	I_{27}	0	1	mA	
Junction temperature	T_j		150	°C	
Storage temperature	T_{stg}	- 40	125	°C	
Thermal resistance system ambient	$R_{th SA}$		53	K/W	

Operating Range

Supply voltage	V_6	10	13.2	V	
Ambient temperature	T_A	0	70	°C	
Input frequency range	f_i	0.01	20	kHz	

www.DataSheet4U.com

Characteristics

$V_S = 12\text{ V}$; $T_A = 25\text{ °C}$, in accordance with test circuit 1

I²C-bus present: start - 84 - 01,3F - 0 2,3F - 0 3,1F - 0 5,88 - 0 6,10 - 07,C8 - 00,01 - stop

Chip address - *Vol_{LSI} 63* - *Vol_{LSr} 63* - *Vol_{HP} 31* - *tone lin* - *adj 0dB* - *MUTE I*, *MUTE II*, *Mono* - *Bypass*

The basic setting for each point in the specification is always preset; only settings which deviate from this are given in the test conditions. Details in *italics* only provide explanation of the hexadecimal code and with switch bits on the set bits and features are stated.

Parameter	Symbol	Limit Values			Unit	Test Condition
		min.	typ.	max.		
Current consumption	I_{21}		50		mA	

Signal Section

Max. gain	V_{16-1}	-2	0	2	dB	
Max. gain	V_{15-3}	-2	0	2	dB	
Max. gain	V_{20-1}	-2	0	2	dB	
Max. gain	V_{19-3}	-2	0	2	dB	
Max. gain	V_{16-3}	-2	0	2	dB	00,02; $V_1 = 01$ <i>Matrix: Stereo</i>
Max. gain	V_{15-3}	-2	0	2	dB	00,02; $V_1 = 01$ <i>Matrix: Stereo</i>
Max. gain	V_{20-3}	-2	0	2	dB	00,02; $V_1 = 0$ <i>Matrix: Stereo</i>
Max. gain	V_{19-3}	-2	0	2	dB	00,02; $V_1 = 0$ <i>Matrix: Stereo</i>
Max. gain	V_{16-1}	4	6	8	dB	00,02; $V_3 = 0$ <i>Matrix: Stereo</i>
Max. gain	V_{20-1}	4	6	8	dB	00,02; $V_3 = 0$ <i>Matrix: Stereo</i>
Max. gain	V_{16-7}	-5	-3	-1	dB	07,CC, SCART
Max. gain	V_{15-8}	-5	-3	-1	dB	07,CC, SCART
Max. gain	V_{20-7}	-5	-3	-1	dB	07,CC, SCART
Max. gain	V_{19-8}	-5	-3	-1	dB	07,CC, SCART
Max. gain	V_{16-6}	-2	0	2	dB	07,C9, Standard L
Max. gain	V_{15-6}	-2	0	2	dB	07,C9, Standard L
Max. gain	V_{20-6}	-2	0	2	dB	07,C9, Standard L
Max. gain	V_{19-6}	-2	0	2	dB	07,C9, Standard L

Characteristics (cont'd)

$V_S = 12\text{ V}$; $T_A = 25\text{ }^\circ\text{C}$, in accordance with test circuit 1

Parameter	Symbol	Limit Values			Unit	Test Condition
		min.	typ.	max.		
Gain	V_{9-1}	-2	0	2	dB	00,02; $V_1 = 0$ Matrix: Stereo
Gain	V_{10-3}	-2	0	2	dB	
Gain	V_{9-3}	-2	0	2	dB	
Gain	V_{10-3}	-2	0	2	dB	00,02; $V_1 = 0$ Matrix: Stereo
Gain	V_{9-1}	4	6	8	dB	00,02; $V_3 = 0$ Matrix: Stereo
Gain	V_{10-6}	-2	0	2	dB	07,C9 Standard L
Gain	V_{9-6}	-2	0	2	dB	07,C9 Standard L
Min. gain	V_{16-1}	-65	-70		dB	01,08-02,08 $Vol_{LSI} 8 - Vol_{LSr} 8$
Min. gain	V_{15-3}	-65	-70		dB	01,08-02,08 $Vol_{LSI} 8 - Vol_{LSr} 8$
Min. gain	V_{20-1}	-57	-62		dB	03,01 $Vol_{HP} 1$
Min. gain	V_{19-3}	-57	-62		dB	03,01 $Vol_{HP} 1$
Min. gain	V_{16-7}	-68	-73		dB	07,CC-01,08-02,08 SCART- $Vol_{LSI} 8 - Vol_{LSr} 8$
Min. gain	V_{15-8}	-68	-73		dB	07,CC-01,08-02,08 SCART- $Vol_{LSI} 8 - Vol_{LSr} 8$
Min. gain	V_{20-7}	-60	-65		dB	07,CC-03,01 SCART- $Vol_{KH} 1$
Min. gain	V_{19-8}	-60	-65		dB	07,CC-03,01 SCART- $Vol_{KH} 1$
Min. gain	V_{16-6}	-60	-70		dB	07,C9-01,08-02,08 Standard L $Vol_{LSI} 8 - Vol_{LSr} 8$
Min. gain	V_{15-6}	-60	-70		dB	07,C9-01,08-02,08 Standard L $Vol_{LSI} 8 - Vol_{LSr} 8$
Min. gain	V_{20-6}	-57	-62		dB	07,C9-03,01 Standard L $Vol_{KH} 1$
Min. gain	V_{19-6}	-57	-62		dB	07,C9-03,01 Standard L $Vol_{KH} 1$
Flutter and wow	ΔV_{15-16}			± 2	dB	01,3F to 01,24 02,3F to 02,24 $Vol_{LSI} 63-36 - Vol_{LSr} 63-36$
Flutter and wow	ΔV_{19-20}			± 2	dB	03,1F to 03,13 $Vol_{KH} 31-19$

SIEMENS AKTIENGESELLSCHAFT

Characteristics (cont'd)

$V_S = 12\text{ V}$; $T_A = 25\text{ °C}$, in accordance with test circuit 1

Parameter	Symbol	Limit Values			Unit	Test Condition
		min.	typ.	max.		
Step width Vol_{15}	ΔV_{15}	0	1.25	2.5	dB	01,X-01, ($X \pm 1$) $Vol_{LSI} X - Vol_{LSI} (X \pm 1)$
Step width Vol_{16}	ΔV_{16}	0	1.25	2.5	dB	02,X-02, ($X \pm 1$) $Vol_{LSr} X - Vol_{LSr} (X \pm 1)$
Step width Vol_{19}	ΔV_{19}	0	2	4	dB	03,X-03, ($X \pm 1$) $Vol_{KH} X - Vol_{KH} (X \pm 1)$
Step width Vol_{20}	ΔV_{20}	0	2	4	dB	03,X-03, ($X \pm 1$) $Vol_{KH} X - Vol_{KH} (X \pm 1)$
Bass boost	V_{16-1}	13	15		dB	05,8F; $f_1 = 40\text{ Hz}$ Bass max, treble lin.
Bass boost	V_{15-3}	13	15		dB	05,8F; $f_1 = 40\text{ Hz}$ Bass max, treble lin.
Bass boost	V_{16-1}	- 10	- 12		dB	05,8F; $f_1 = 40\text{ Hz}$ Bass max, treble lin.
Bass boost	V_{15-3}	- 10	- 12		dB	05,8F; $f_1 = 40\text{ Hz}$ Bass max, treble lin.
Step wide bass	ΔV_{15}	1	3	5	dB	05,8X-05,8 ($X \pm 1$) Bass X - bass ($X \pm 1$)
Step wide bass	ΔV_{16}	1	3	5	dB	05,8X-05,8 ($X \pm 1$) Bass X - bass ($X \pm 1$)
High frequency emphasis	V_{16-1}	10	12		dB	05,8F; $f_1 = 15\text{ kHz}$ Treble max, bass lin.
High frequency emphasis	V_{15-3}	10	12		dB	05,8F; $f_1 = 15\text{ kHz}$ Treble max, bass lin.
High frequency emphasis	V_{16-1}	- 10	- 12		dB	05,8F; $f_1 = 15\text{ kHz}$ Treble max, bass lin.
High frequency emphasis	V_{15-3}	- 10	- 12		dB	05,8F; $f_1 = 15\text{ kHz}$ Treble max, bass lin.
Step wide treble	ΔV_{15}	1	3	5	dB	05,X8-0,5 ($X \pm 1$) 8 Treble X - treble ($X \pm 1$)
Step wide treble	ΔV_{16}	1	3	5	dB	05,X8-0,5 ($X \pm 1$) 8 Treble X - treble ($X \pm 1$)
Linearity sound	ΔV_{15}			± 2	dB	05,88; $f_1 = 40\text{ Hz} - 15\text{ kHz}$ Treble, bass lin.
Linearity sound	ΔV_{16}			± 2	dB	05,88; $f_1 = 40\text{ Hz} - 15\text{ kHz}$ Treble, bass lin.
Channel separation	ΔV_{15-16}	50			dB	V_3 or $V_1 = 600\text{ mVrms}$
Channel separation	ΔV_{19-20}	50			dB	V_3 or $V_1 = 600\text{ mVrms}$
Channel separation	ΔV_{9-10}	50			dB	V_3 or $V_1 = 600\text{ mVrms}$

Characteristics (cont'd)

$V_S = 12\text{ V}$; $T_A = 25\text{ }^\circ\text{C}$, in accordance with test circuit 1

Parameter	Symbol	Limit Values			Unit	Test Condition
		min.	typ.	max.		
Cross talk attenuation switch	$\alpha_{\text{input interf / Output rms}}$	60			dB	$V_{1\text{ rms}} = 0$ $V_{1\text{ Int}1,3,6} = 600\text{ mVrms}$ $V_{1\text{ Int}7,8} = 2\text{ Vrms}$
Attenuation MUTE	α_{1-16}	80			dB	01,00-02,00 $Vol_{LSI} 0 - Vol_{LSr} 0$ $V_1 = 600\text{ mVrms}$
Attenuation MUTE	α_{1-16}	80			dB	07,48; $V_1 = 600\text{ mVrms}$ MUTE I: 0
Attenuation MUTE	α_{1-16}	80			dB	07,88; $V_1 = 600\text{ mVrms}$ MUTE II: 0
Attenuation MUTE	α_{3-15}	80			dB	01,00-02,00 $Vol_{LSI} 0 - Vol_{LSr} 0$ $V_3 = 600\text{ mVrms}$
Attenuation MUTE	α_{3-15}	80			dB	07,48; $V_3 = 600\text{ mVrms}$ MUTE I: 0
Attenuation MUTE	α_{3-15}	80			dB	07,88; $V_3 = 600\text{ mVrms}$ MUTE II: 0
Attenuation MUTE	α_{1-20}	80			dB	03,00; $V_1 = 600\text{ mVrms}$ $Vol_{KH} 0$
Attenuation MUTE	α_{1-20}	80			dB	07,48; $V_1 = 600\text{ mVrms}$ MUTE I: 0
Attenuation MUTE	α_{3-19}	80			dB	03,00; $V_3 = 600\text{ mVrms}$ $Vol_{KH} 0$
Attenuation MUTE	α_{3-19}	80			dB	07,48; $V_3 = 600\text{ mVrms}$ MUTE I: 0
Analog values are valid for feed-in at the pin 6, 7, 8; $V_{7,8} = 2\text{ Vrms}$; $V_6 = 600\text{ mVrms}$						
Attenuation MUTE	α_{3-10}	80			dB	07,48; $V_3 = 600\text{ mVrms}$ MUTE I: 0
Attenuation MUTE	α_{1-9}	80			dB	07,48; $V_3 = 600\text{ mVrms}$ MUTE I: 0
Attenuation MUTE	α_{6-10}	80			dB	07,49; $V_6 = 600\text{ mVrms}$ MUTE I: 0, Standard L
Attenuation MUTE	α_{6-9}	80			dB	07,49; $V_6 = 600\text{ mVrms}$ MUTE I: 0, Standard L

SIEMENS AKTIENGESELLSCHAFT

Characteristics (cont'd)

$V_S = 12\text{ V}$; $T_A = 25\text{ }^\circ\text{C}$, in accordance with test circuit 1

Parameter	Symbol	Limit Values			Unit	Test Condition
		min.	typ.	max.		
Max. input voltage	V_6	600			mVrms	$THD_{15,16} = 1\%$
Max. input voltage	V_3	600			mVrms	$THD_{15} = 1\%$
Max. input voltage	V_1	600			mVrms	$THD_{16} = 1\%$
Max. input voltage	V_1	300			mVrms	$THD_{16} = 1\%$; 00,02 <i>Matrix: Stereo</i>
Max. input voltage	V_7	2			Vrms Vrms	$THD_{16} = 1\%$ 07, CC, SCART
Max. input voltage	V_8	2			%	$THD_{15} = 3\%$ 07, CC, SCART
Distorsion	THD_{19}	0	0.01	0.1	%	$V_3 = 250\text{ mVrms}$
Distorsion	THD_{20}		0.01	0.1	%	$V_1 = 250\text{ mVrms}$
Distorsion	THD_{19}		0.01	0.1	%	$V_3 = 250\text{ mVrms}$; 03,15 $Vol_{KH} 21$
Distorsion	THD_{20}		0.01	0.1	%	$V_1 = 250\text{ mVrms}$; 03,15 $Vol_{KH} 21$

Analog values are valid for feed-in at the pin 6, 7, 8; $V_{7,8} = 2\text{ Vrms}$; $V_6 = 250\text{ mVrms}$

Distorsion	THD_{16}		0.01	0.1	%	$V_1 = 250\text{ mVrms}$
Distorsion	THD_{15}		0.01	0.1	%	$V_3 = 250\text{ mVrms}$
Distorsion	THD_{16}		0.01	0.2	%	$V_1 = 250\text{ mVrms}$; 01 2F-02,2F $Vol_{LSI} 47$ - $Vol_{LSr} 47$
Distorsion	THD_{15}		0.01	0.2	%	$V_3 = 250\text{ mVrms}$; 01 2F-02,2F $Vol_{LSI} 47$ - $Vol_{LSr} 47$
Distorsion	THD_{16}		0.01	0.4	%	$V_1 = 250\text{ mVrms}$; 05,XX <i>any sound</i>
Distorsion	THD_{15}		0.01	0.4	%	$V_3 = 250\text{ mVrms}$; 05,XX <i>any sound</i>

Analog values are valid for feed-in at the pin 6, 7, 8; $V_{7,8} = 2\text{ Vrms}$; $V_6 = 250\text{ mVrms}$

Distorsion	THD_{10}		0.01	0.1	%	$V_3 = 250\text{ mVrms}$
Distorsion	THD_9		0.01	0.1	%	$V_1 = 250\text{ mVrms}$
Distorsion	THD_{10}		0.01	0.1	%	$V_6 = 250\text{ mVrms}$ 07,C9, Standard L
Distorsion	THD_9		0.01	0.1	%	$V_1 = 250\text{ mVrms}$ 07,C9, Standard L
Antiphase Cross talk atten.	ΔV_{16-15}	0.5	0.55			$V_3 = 600\text{ mVrms}$
Base width						$f_1 = 2\text{ kHz}$; 00,11, <i>Basis width</i>

Characteristics (cont'd)

$V_S = 12\text{ V}$; $T_A = 25\text{ °C}$, in accordance with test circuit 1

Parameter	Symbol	Limit Values			Unit	Test Condition
		min.	typ.	max.		
Antiphase Cross talk atten.	ΔV_{16-15}	0.5	0.55			$V_3 = 600\text{ mVrms}$
Base width						$f_1 = 2\text{ kHz}$; 00,11, <i>Basis width</i>
Base width phase	Φ_{16-15}	150	180	210	deg	$V_1 = 600\text{ mVrms}$; 00,11 <i>Basis width, f = 2 kHz</i>
Base width phase	Φ_{15-16}	150	180	210	deg	$V_1 = 600\text{ mVrms}$; 00,11 <i>Basis width, f = 2 kHz</i>
Phase rotation quasi stereo	Φ_{16-15}	0	10	40	deg	$V_{3,1} = 600\text{ mVrms}$; 00,21 <i>Quasi stereo, f = 40 Hz</i>
Phase rotation quasi stereo	Φ_{16-15}	130	180	230	deg	$V_{3,1} = 600\text{ mVrms}$; 00,21 <i>Quasi stereo, f = 1 kHz</i>
Phase rotation quasi stereo	Φ_{16-15}	-30	10	0	deg	$V_{3,1} = 600\text{ mVrms}$; 00,21 <i>Quasi stereo, f = 15 kHz</i>
Unweighted signal- to-noise ratio	$\alpha_{S/N16}$	1	90	97	dB	$V_{N\text{ rms } 20\text{ Hz-20 kHz}}$; $V_1 = 0.6\text{ Vrms}$
Unweighted signal- to-noise ratio	$\alpha_{S/N15}$	1	90	97	dB	$V_{N\text{ rms } 20\text{ Hz-20 kHz}}$; $V_3 = 0.6\text{ Vrms}$
Unweighted signal- to-noise ratio	$\alpha_{S/N16}$	70	80		dB	$V_{N\text{ rms } 20\text{ Hz-20 kHz}}$; $V_1 = 0.6\text{ Vrms}$ 01,27-02,27 <i>Vol_{LSr} 39-Vol_{LSr} 39</i>
Unweighted signal- to-noise ratio	$\alpha_{S/N15}$	70	80		dB	$V_{N\text{ rms } 20\text{ Hz-20 kHz}}$; $V_3 = 0.6\text{ Vrms}$ 01,27-02,27 <i>Vol_{LSr} 39-Vol_{LSr} 39</i>
External voltage	V_{N15}		2	10	μVrms	$V_{N\text{ rms } 20\text{ Hz-20 kHz}}$ 01,00-02,00 <i>Vol_{LSr} 0-Vol_{LSr} 0</i>
External voltage	V_{N16}		2	10	μVrms	$V_{N\text{ rms } 20\text{ Hz-20 kHz}}$ 01,00-02,00 <i>Vol_{LSr} 0-Vol_{LSr} 0</i>

SIEMENS AKTIENGESELLSCHAFT

Characteristics (cont'd)

$V_S = 12\text{ V}$; $T_A = 25\text{ °C}$, in accordance with test circuit 1

Parameter	Symbol	Limit Values			Unit	Test Condition
		min.	typ.	max.		
Unweighted signal-to-noise ratio	$\alpha_{S/N20}$	90	97		dB	$V_{N\text{ rms } 20\text{ Hz-20 kHz}}$; $V_1 = 0.6\text{ Vrms}$
Unweighted signal-to-noise ratio	$\alpha_{S/N19}$	1	90	97	dB	$V_{N\text{ rms } 20\text{ Hz-20 kHz}}$; $V_3 = 0.6\text{ Vrms}$
Unweighted signal-to-noise ratio	$\alpha_{S/N20}$	70	80		dB	$V_{N\text{ rms } 20\text{ Hz-20 kHz}}$; $V_1 = 0.6\text{ Vrms}$ 03,10, $Vol_{KH} 16$
Unweighted signal-to-noise ratio	$\alpha_{S/N19}$	70	80		dB	$V_{N\text{ rms } 20\text{ Hz-20 kHz}}$; $V_3 = 0.6\text{ Vrms}$ 03,10, $Vol_{KH} 16$
External voltage	V_{N20}		2	10	μVrms	$V_{N\text{ rms } 20\text{ Hz-20 kHz}}$; 03,00 $Vol_{KH} 0$
External voltage	V_{N19}		2	10	μVrms	$V_{N\text{ rms } 20\text{ Hz-20 kHz}}$; 03,00 $Vol_{KH} 0$
Unweighted signal-to-noise ratio	$\alpha_{S/N9}$	1	90	97	dB	$V_{N\text{ rms } 20\text{ Hz-20 kHz}}$; $V_1 = 0.6\text{ Vrms}$
Unweighted signal-to-noise ratio	$\alpha_{S/N10}$	1	90	97	dB	$V_{N\text{ rms } 20\text{ Hz-20 kHz}}$; $V_1 = 0.6\text{ Vrms}$
Change of DC-switch $\Delta 1$ Bit	ΔV_{16}			± 10	mV	01,X-01,X ± 1 $Vol_{LSI} X - Vol_{LSI} (X \pm 1)$
Change of DC-switch $\Delta 1$ Bit	ΔV_{15}			± 10	mV	02,X-02,X ± 1 $Vol_{LSr} X - Vol_{LSr} (X \pm 1)$
Change of DC-switch $\Delta 1$ Bit	ΔV_{16}			± 10	mV	05,X-05,X ± 1 Sound X-Sound (X ± 1)
Change of DC-switch $\Delta 1$ Bit	ΔV_{15}			± 10	mV	05,X-05,X ± 1 Sound X-Sound (X ± 1)
Change of DC-switch $\Delta 1$ Bit	ΔV_{19}			± 10	mV	03,X-03,X ± 1 $Vol_{KH} X - Vol_{KH} (X \pm 1)$
Change of DC-switch $\Delta 1$ Bit	ΔV_{20}			± 10	mV	03,X-03,X ± 1 $Vol_{KH} X - Vol_{KH} (X \pm 1)$

Characteristics (cont'd)

$V_S = 12\text{ V}$; $T_A = 25\text{ }^\circ\text{C}$, in accordance with test circuit 1

Parameter	Symbol	Limit Values			Unit	Test Condition
		min.	typ.	max.		

Design-Related Data

Input resistance	R_7	35			$\text{k}\Omega$	
Input resistance	R_8	35			$\text{k}\Omega$	
Input resistance	R_6	20			$\text{k}\Omega$	
Input resistance	R_3	20			$\text{k}\Omega$	
Input resistance	R_1	20			$\text{k}\Omega$	
Output resistance	R_{19}			200	Ω	
Output resistance	R_{20}			200	Ω	
Output resistance	R_{15}			200	Ω	
Output resistance	R_{16}			200	Ω	
Output resistance	R_9			200	Ω	
Output resistance	R_{10}			200	Ω	

SIEMENS AKTIENGESELLSCHAFT

Characteristics (cont'd)

$V_S = 12\text{ V}; T_A = 25\text{ }^\circ\text{C}$

Parameter	Symbol	Limit Values			Unit	Test Condition	Test Circuit
		min.	typ.	max.			

ID-Signal Decoder

Gain Filter OP-amp	V_5	13	14	15	dB	$V_{IF} = 80\text{ mVpp}$	1
Max. input voltage	V_5	6			mVpp	Function	2
VCO voltage PLL	V_{27}	1.3			V	$f_{24} = 14.6\text{ kHz};$ $V_{24} = 2.5\text{ V}_{OS}$	2
VCO voltage PLL	V_{27}	2	3	4	V	$f_{24} = 15.625\text{ kHz};$ $V_{24} = 2.5\text{ V}_{OS}$	2
VCO voltage PLL	V_{27}			4.7	V	$f_{24} = 16.6\text{ kHz};$ $V_{24} = 2.5\text{ V}_{OS}$	2
VCO voltage PLL	V_{27}	1.3			V	$f_{24} = 58.4\text{ kHz};$ $V_{24} = 2.5\text{ V}_{OS}$ 00,09, H-Imp	2
VCO voltage PLL	V_{27}			4.7	V	$f_{24} = 66.4\text{ kHz};$ $V_{24} = 2.5\text{ V}_{OS}$ 00,09, H-Imp	2

$$V_{KT\text{ FILTER}} = \frac{\sqrt{(V_{25} - V_{25}^*)^2 + (V_{26} - V_{26}^*)^2}}{V_5} \quad \begin{array}{l} V_{25} \text{ or } V_{26} \text{ when } V_5 = 0 \\ V_{25}^* \text{ or } V_{26}^* \text{ when } V_5 = 400\text{ mVpp} \end{array}$$

ID-filter gain	$V_{KT\text{ Filter}}$	3.4		6.8		$f_5 = \text{Pilot signal: Dual}$ I ² C-talk: Dual	
ID-filter gain	$V_{KT\text{ Filter}}$	3.4		6.8		$f_5 = \text{Pilot signal: Stereo}$ I ² C-talk: Stereo	

$$V_{25\text{ test}} = V_{25} (V_5 = 0) \pm \Delta V_{25}; \quad V_{26\text{ test}} = V_{26} (V_5 = 0) \pm \Delta V_{26}$$

Detection threshold	ΔV_{25}	900			mV	I ² C-talk: Stereo o. Dual	3
Detection threshold	$-\Delta V_{25}$	900			mV	I ² C-talk: Stereo o. Dual	3
Detection threshold	ΔV_{26}	900			mV	I ² C-talk: Stereo o. Dual	3
Detection threshold	$-\Delta V_{26}$	900			mV	I ² C-talk: Stereo o. Dual	3

Characteristics (cont'd)
 $V_S = 12\text{ V}; T_A = 25\text{ }^\circ\text{C}$

Parameter	Symbol	Limit Values			Unit	Test Condition	Test Circuit
		min.	typ.	max.			
Mono threshold	ΔV_{25}	0		100	mV	I ² C-talk: Mono	3
Mono threshold	$-\Delta V_{25}$	0		100	mV	I ² C-talk: Mono	3
Mono threshold	ΔV_{26}	0		100	mV	I ² C-talk: Mono	3
Mono threshold	$-\Delta V_{26}$	0		100	mV	I ² C-talk: Mono	3
Detection response	t_{det}	1/4		1/2	t_{MPX}	I ² C-talk: Stereo o. Dual $\pm \Delta V_{25} = 1\text{ V}$	3
Detection response	t_{det}	1/4		1/2			
Switching threshold f_{REF} -input	V_{24L}	0		1.5	V		2
Switching threshold f_{REF} -input	V_{24L}	3.5		V_{21}	V		2
Multiplexer clock	t_{MPX}		1.08		s	00,C0, $MPX = 1\text{ s}$	
Multiplexer clock	t_{MPX}		2.17		s	00,C0, $MPX = 2\text{ s}$	
Multiplexer clock	t_{MPX}		4.34		s	00,C0, $MPX = 4\text{ s}$	
Multiplexer clock	t_{MPX}		8.68		s	00,C0, $MPX = 8\text{ s}$	

Design-Related Data

Filter output resistance	$R_{25, 26}$	110			k Ω		
f_{REF} -input resistance	R_{24}	7			k Ω		

SIEMENS AKTIENGESELLSCHAFT

Characteristics

$V_S = 12\text{ V}$; $T_A = 25\text{ °C}$

Parameter	Symbol	Limit Values			Unit
		min.	typ.	max.	
I²C-Bus (SCL, SDA)					
SCL, SDA edges					
Rise time	t_R			1	μs
Fall time	t_F			300	ns
Shift register clock pulse SCL					
Frequency	f_{SCL}	0		100	kHz
H-pulse width	t_{HIGH}	4			μs
L-pulse width	t_{LOW}	4			μs
Start					
Setup time	t_{SUSTA}	4			μs
Hold time	t_{HDSTA}	4			μs
Stop					
Setup time	t_{SUSTO}	4			μs
Bus free time	t_{BUF}	4			μs
Data transfer					
Setup time	t_{SUDAT}	1			μs
Hold time	t_{HDDAT}	1			μs
Input SCL, SDA					
Input voltage	V_{QH} V_{QL}	2.4		5.5 1	V V
Input current	I_{QH} I_{QL}			20 20	μA μA
Output SDA (open collector)					
Output voltage	V_{QH} V_{QL}	5.4			V V
$R_L = 2.5\text{ k}\Omega$ $I_{\text{QL}} = 3\text{ mA}$				0.4	

SIEMENS AKTIENGESELLSCHAFT

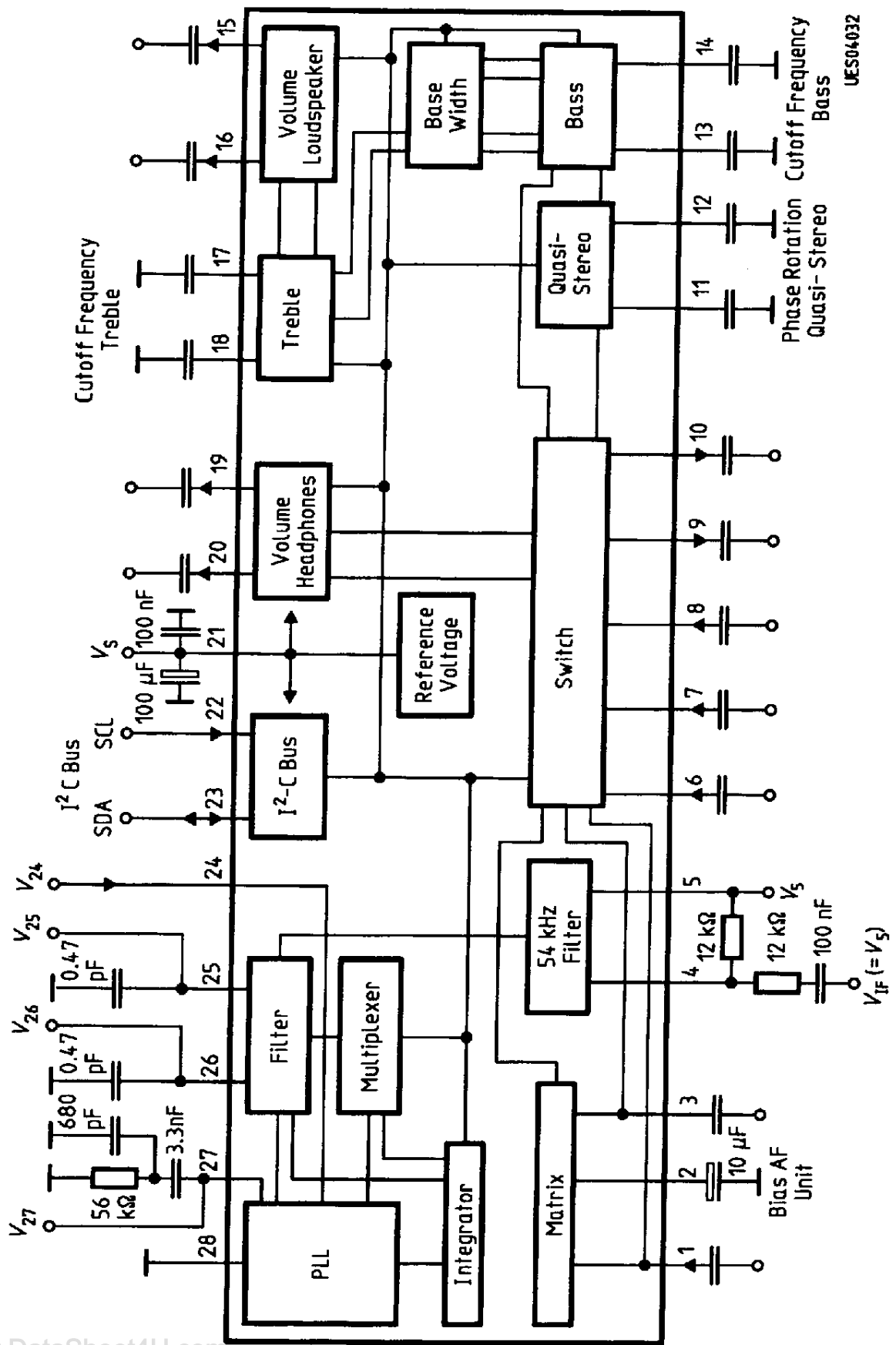

UES04032

www.DataSheet4U.com

Test Circuit 2

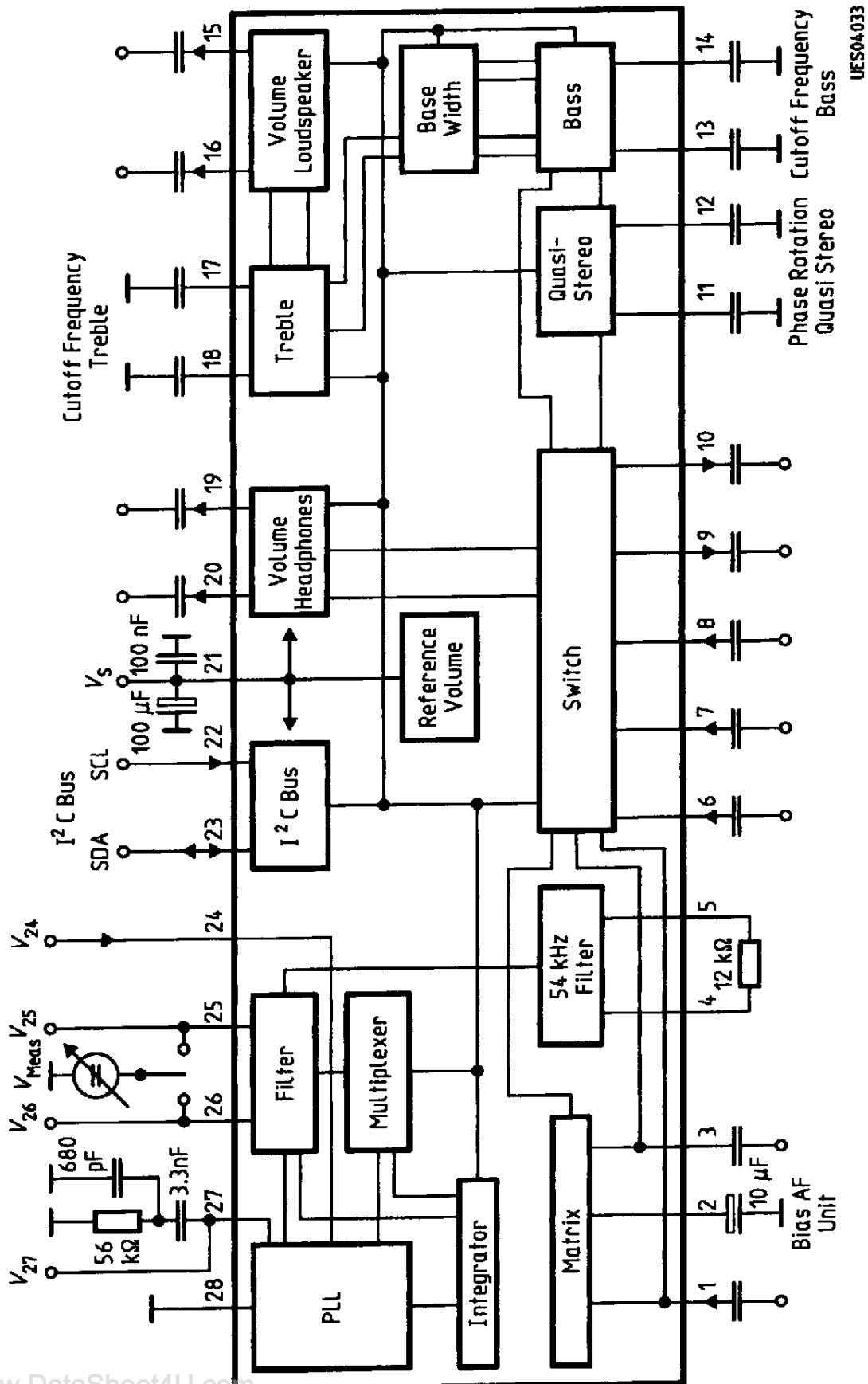

UES04.033

www.DataSheet4U.com

Test Circuit 3

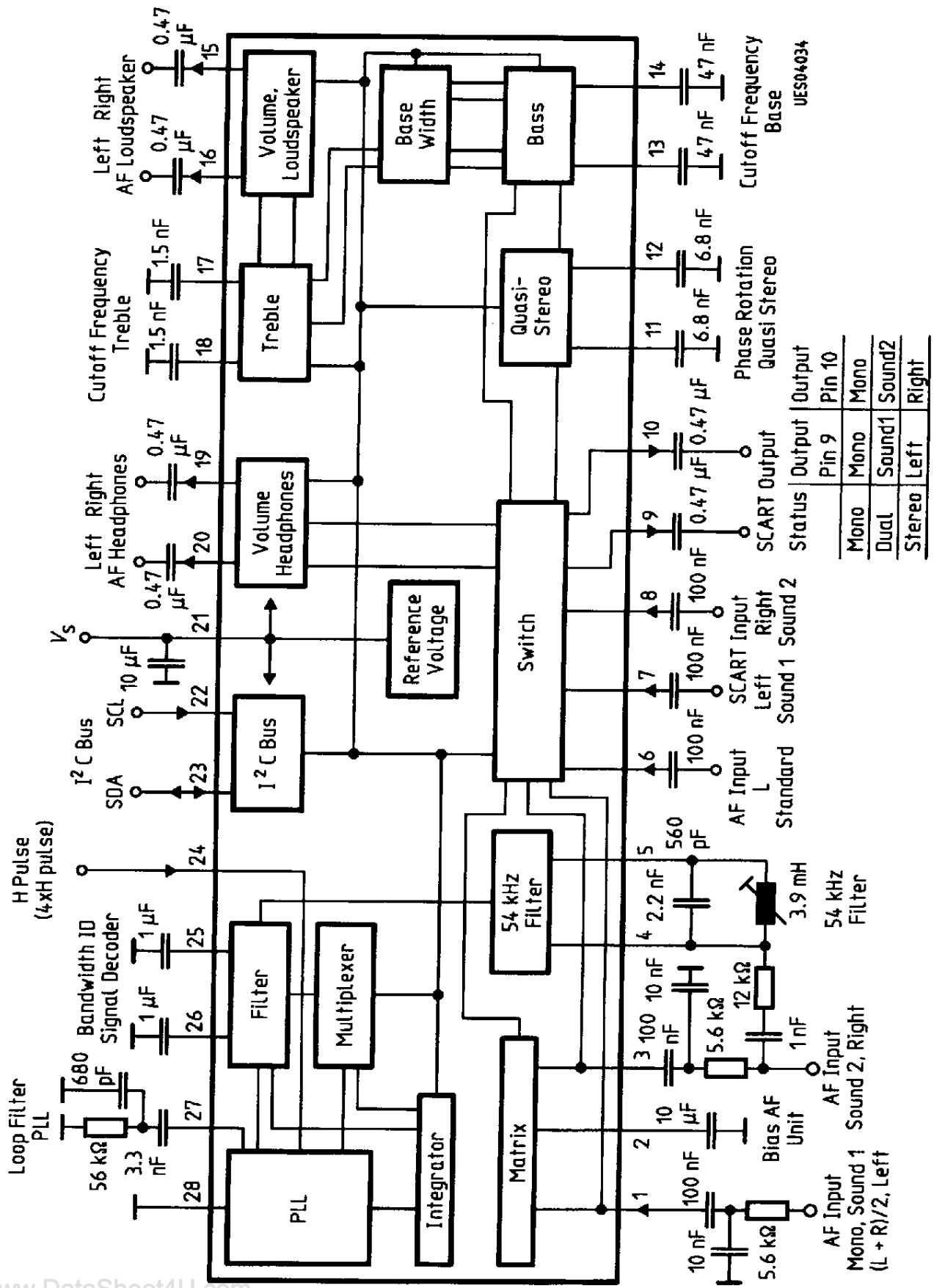

Status	Output Pin 9	Output Pin 10
Mono	Mono	Mono
Dual	Sound1	Sound2
Stereo	Left	Right

www.DataSheet4U.com

Application Circuit 1

SIEMENS AKTIENGESELLSCHAFT

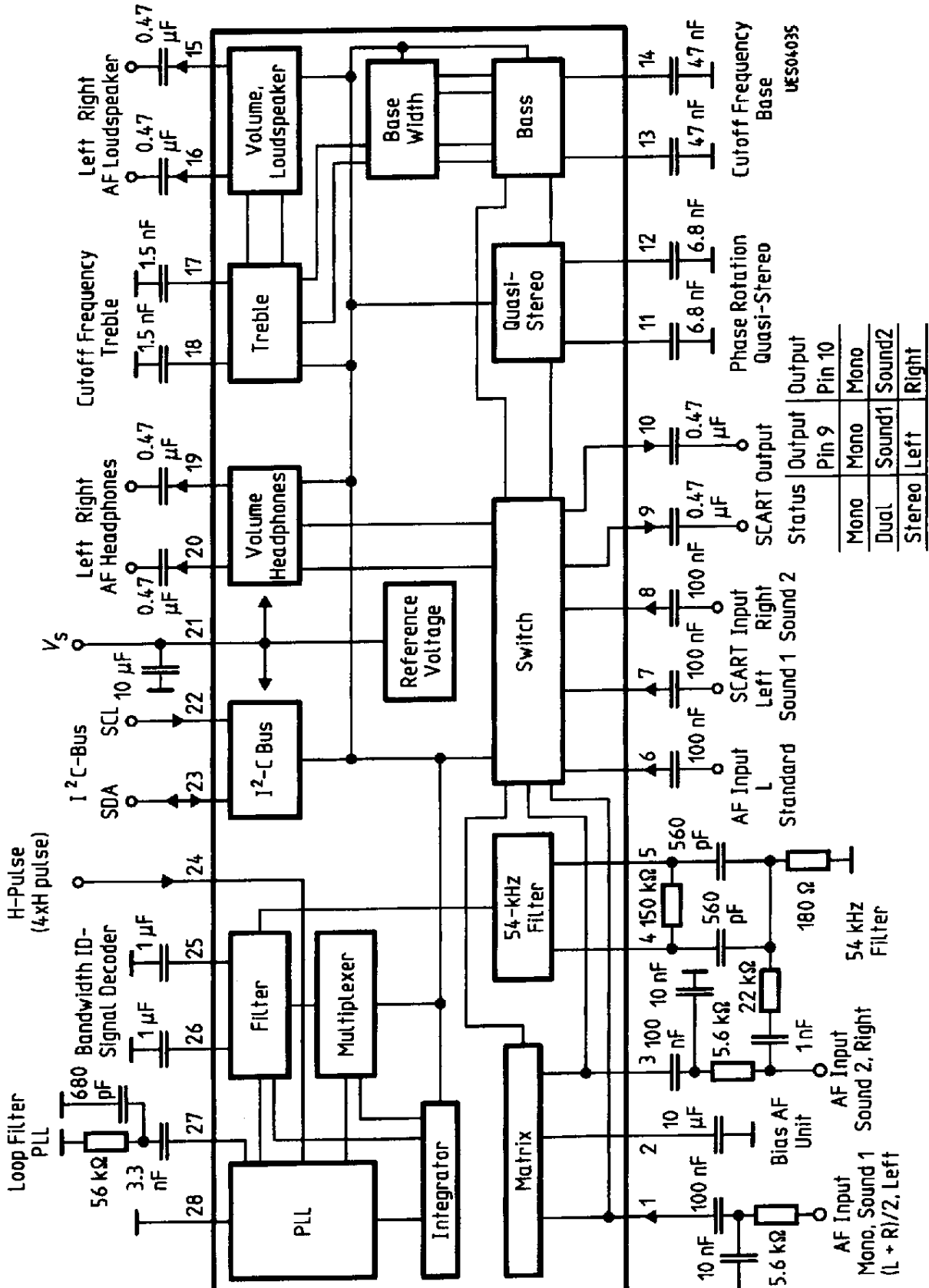

U6504035

Output	Pin 9	Pin 10
Mono	Mono	Mono
Dual	Sound1	Sound2
Stereo	Left	Right

www.DataSheet4U.com

Application Circuit 2

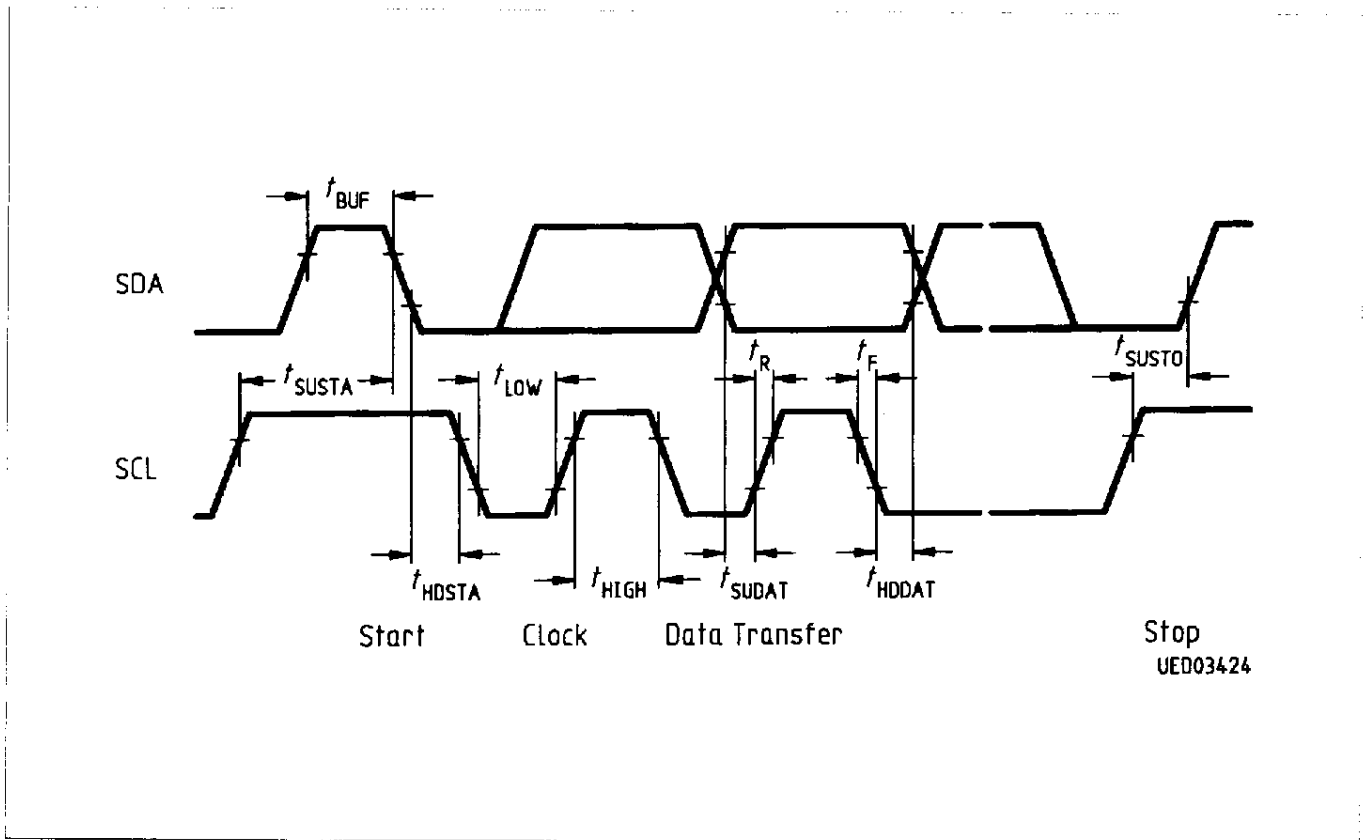

I²C-Bus Timing Diagram

t_{SUSTA}	Setup time (start)
t_{HDSTA}	Hold time (start)
t_{HIGH}	H-pulse width (clock)
t_{LOW}	L-pulse width (clock)
t_{SUDAT}	Setup time (data transfer)
t_{HDDAT}	Hold time (data transfer)
t_{SUSTO}	Setup time (stop)
t_{BUF}	Bus free time
t_F	Fall time
t_R	Rise time

All times referred to V_{IH} and V_{IL} values.