

TV-Stereo-Sound

TDA 6612-5

Preliminary Data

Bipolar IC

Features

The TDA 6612-5 represents a complete TV-stereo system controlled by the I²C Bus according to German TV-Stereo standard.

- All functions inclusive matrix adjustment are I²C Bus controlled
- Inputs for AM sound or NICAM
- SCART-interface
- Independent headphones
- Universal clock generation circuit build-in
- Clipping detector build-in
- Volume control
- High signal-to-noise ratio
- Extremely low total harmonic distortions
- High security for the detection of the identification signals because of the digital interference suppression and the very narrow bandwidth

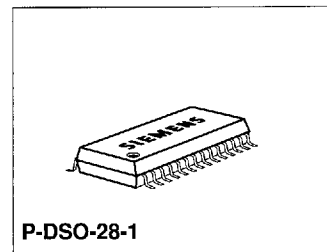
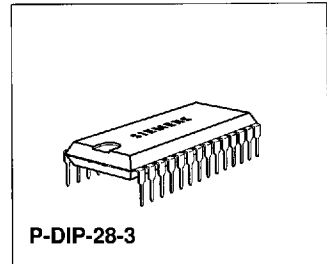

Type	Ordering Code	Package
TDA 6612-5	Q67000-A5130	P-DIP-28-3
TDA 6612-5X	Q67000-A5197	P-DSO-28-1

The IC is divided into three functional blocks

1. Stereo Sound Processing with High Performance (exceeds DIN 45500; suitable for NICAM and CD)

- a) Matrix for G-standard with crosstalk compensation controlled via the I²C Bus
- b) Additional single channel AF input (for e.g. AF signal according to L-standard)
- c) Stereo SCART interface according to FTZ-official specification
- d) Stereo loudspeaker signal section with Ch1/Ch2 switch, bass/treble control, quasi stereo/stereo base width expansion and separate loudspeaker volume control for left and right (balance)
- e) Separate stereo head phone signal section with Ch1/Ch2 switch and volume control

2. TV Sound Identification Signal Decoder Consisting of:

- a) Active pilot signal filter
- b) Phase independent rectifier with very narrow bandwidth for evaluation of the identification signal
- c) Digital integrator to reduce interferences by noise
- d) Multiplexer for cyclical switch over between "stereo" or "dual" evaluation
- e) Reference signal generation with externally synchronized PLL
 - synchronization with external H-sync pulse or 62.5-kHz clock
 - build-in crystal oscillator and external 4-MHz crystal
 - external 4-MHz (or 1-MHz) clock signal

Control Section for:

- a) I²C Bus interface with listen/talk function
- b) Control of the complete AF-sound signal detector
- c) Read access to the clipping detector
- d) Control of the identification signal decoder
- e) Reading of the status of the identification signal decoder
- f) Test modes

Circuit Description

Signal Section

The audio signal processing in the matrix and the switch-over for multi channel TV-sound signals according to the two carrier system used in Germany takes place in the matrix and switching sections. Crosstalk compensation is carried out in the sound 1 input stage. The crosstalk compensation range has an adjustment range of ± 3 dB with a step width of 0.2 dB. In addition to the two inputs for the demodulated sound carrier a two channel SCART input and an additional mono input (e.g. for demodulated L-standard sound) are provided. The two AF (pin 1 and pin 2) inputs can be bypassed internally in such a way that decoded stereo sound of other audio systems (NICAM) can be processed. The switching section includes also the SCART output with the possibility to select the sound 1 or 2 during the "Dual" mode. The Ch1/Ch2 switches for the loudspeaker and headphone outputs are independently switchable.

In the signal path for the volume control unit output there is the Ch1/Ch2 switch followed by two different volume control units. The first has a control range from 0 to -15 dB with a step width of 1.25 dB. In conjunction with the main volume control after bass and treble control a high immunity against overdriving the output stage is reached. The first volume control is used as a "pre-stage" of the main volume control in conjunction with the clipping detector. This section is followed by a switchable quasi stereo stage which provides a stereophonic audio effect with mono signals due to a 180° phase shift at medium frequencies (about 1 kHz) in one channel. The following bass control has a control range of $+15/-12$ dB with a step width of 3 dB. The cut-off frequency for each channel is set with an external capacitor. The implemented switchable circuit for stereo base width expansion provides a three dimensional aural reception. This is realized with a 50% frequency dependent crosstalk with opposite phase of the signal between both channels. The circuit operates with the same cut-off frequency as the bass control, but the function is widely independent. The treble control has a step width of 3 dB with an control range of ± 12 dB. The cut-off frequency of the treble control is derived from one capacitor for each channel. The loudspeaker signal path is terminated with the loudspeaker control, independently adjustable for left and right. With 57 steps of 1.25 dB the adjustment range is 70 dB, where step 57 activates the "MUTE" function. Functions such as "balance" or "loudness" are realized by software and adjustment of the appropriate tone and volume controls. In the volume control unit there is a clipping detector. The status of the clipping detector can be evaluated via the I²C Bus. Therefore it is possible to implement an automatic volume control using the clipping detector and software implemented into the controller.

After every evaluation the clipping bit is reset. Therefore after a read access to the clipping bit a new evaluation of the clipping detector status is possible.

The signal path for the headphones contains a volume control after the Ch1/Ch2 switch with a common adjustment for left and right. Thirty two steps of 2 dB give an adjustment range of 62 dB (31 x 2 dB = 62 dB, the 32nd step is MUTE).

Identification Signal Decoder

The input of the identification signal decoder consists of an op-amp for the pilot signal with its side bands. An external LC circuit is used. The signal is then passed to a phase independent active band-pass filter with a very narrow bandwidth (adjustable externally). This filter detects whether the lower side band of the pilot carrier, which is modulated with the identification signal, is present. The

center frequency of the filter is switched between "dual" and "stereo" by a multiplexer. The multiplexing frequency is adjustable by software. If a side band is detected, the multiplexer stops. The interferences on the first "detected" criterion are suppressed by a digital integrator with a following comparator and can be read out via I²C Bus (talk mode) as the "stereo" or "dual" mode. The control of the corresponding signal can be either directly internally or through the μ C. All the necessary clock signal are derived from a fast setting PLL which is synchronized by a reference frequency. This reference frequency must be sufficiently close to the horizontal frequency, but a **rigid phase coupling is not required**. Therefore, alternatively the use of a crystal controlled 62.5-kHz frequency commonly found in PLL-tuning systems is possible. A further alternative for the clock signal generation is a build-in crystal oscillator with an external 4-MHz crystal or the use an external 1- or 4-MHz clock frequency.

Control Section

All functions are controlled via an I²C Bus interface with "listen" / "talk" functions. The data bytes currently used are stored in a block of latches.

The telegram structure is formed in the following manner:

start condition - chip address - any number of bytes - stop condition

The following conditions apply to the data bytes:

Before the actual data byte (with the adjustment information), always an I²C Bus sub-address byte has to be transmitted. The I²C Bus interface however is interpreting this sub-address byte as a data byte.

Example: The headphone volume is to be increased in a number of steps.

Right	Wrong
Start condition	Start condition
Chip address 84 (Hex)	Chip address 84 (Hex)
Sub-addr. vol. HP 03 (Hex)	Sub-addr. vol. HP 03 (Hex)
Vol. step 8 08 (Hex)	Vol. step 8 08 (Hex)
Sub-addr. vol HP 03 (Hex)	Vol. step 9 09 (Hex)
Vol. step 9 09 (Hex)	Vol. step 10 0A (Hex)
Sub-addr. vol. HP 03 (Hex)	Stop condition
Vol. step 10 0A (Hex)	
Stop condition	

Within a telegram (i.e. without a new start condition) any different sub-addresses can be accessed. The changeover between "listen" and "talk" access to the IC however must always occur using the following sequence: stop condition - start condition - chip address. Before each read access always a start condition and chip address (talk) must be transmitted. The data to be read out are then loaded into the I²C Bus interface and can be transferred to the μ C.

Chip Address

MSB	LSB
1	0	0	0	0	1	0	R/W

R/W = 0 → Read (Listen)

R/W = 1 → Write (Talk)

Subaddress Bytes

	MSB	LSB
Volume input control	X	X	X	X	X	1	0	0
Volume of left speaker	X	X	X	X	X	0	0	1
Volume of right speaker	X	X	X	X	X	0	1	0
Volume of headphones	X	X	X	X	X	0	1	1
Treble / bass	X	X	X	X	X	1	0	1
Switch byte I	X	X	X	X	X	1	1	1
Switch byte II	X	X	X	X	X	0	0	0
Crosstalk adjustment	X	X	X	X	X	1	1	0

Control Bytes

a) Volume Input Control

	MSB	LSB
Maximum volume	Qu-H	Ch1/Ch2 EN	Ch1/Ch2sc	0	0	0	0	MUTE III
Max - 1	Qu-H	Ch1/Ch2 EN	Ch1/Ch2sc	0	0	0	1	MUTE III
Min + 1	Qu-H	Ch1/Ch2 EN	Ch1/Ch2sc	1	0	1	1	MUTE III
Minimum volume	Qu-H	Ch1/Ch2 EN	Ch1/Ch2sc	1	1	0	0	MUTE III
Power ON	0	0	0	0	0	0	0	1

Qu-H = 0 PLL synchronization with H-pulse; power ON

Qu-H = 1 PLL synchronization with crystal oscillator,
 additionally the bit "H-pulse" has to be set to "H" in switch byte II

Ch1/Ch2 EN	Ch1/Ch2 sc	SCART output	SCART output
		pin 9	pin 10
0	0	sound 1	sound 2
0	1	sound 2	sound 1
1	0	sound 1	sound 1
1	1	sound 2	sound 2

CH1/Ch2 EN, Ch1/Ch2 sc are only activated if the matrix is in the dual mode

(switch byte II: matrix 0 = 1 and matrix 1 = 0 or matrix 0 = 1 , matrix 1 = 1 and the identification decoder is in the mode "dual")

MUTE III = 0 SCART output are muted.

MUTE III = 1 SCART output ON; power ON

(will be overwritten by MUTE 1 = 0 equal to all audio outputs muted)

MUTE III is "or" wired with MUTE I.

b) Volume of Left / Right Loudspeaker

	MSB	LSB
Maximum volume	X	X	1	1	1	1	1	1
Max -1	X	X	1	1	1	1	1	0
Max -15	X	X	1	1	0	0	0	0
Max -55	X	X	0	0	1	0	0	0
MUTE	X	X	0	0	0	1	1	1
MUTE	X	X	0	0	0	0	0	0
MUTE	X	X	0	0	0	X	X	X
Power ON	0	0	0	0	0	0	0	1

c) Volume of Headphones

	MSB	LSB
Maximum volume	T2	T1	T0	1	1	1	1	1
Max -1	T2	T1	T0	1	1	1	1	0
Max -15	T2	T1	T0	1	0	0	0	0
Max -31	T2	T1	T0	0	0	0	0	1
MUTE	T2	T1	T0	0	0	0	0	0
Power ON	0	0	0	0	0	0	0	1

T0 T2 are test bits; these must be set to 0 for normal operation

d) Crosstalk Compensation Matrix (sound 1)

	MSB	LSB
Max. amplification	0	0	0	1	1	1	1	1
Max -1	0	0	0	1	1	1	1	0
Gain 0 dB	0	0	0	1	0	0	0	0
Min. gain	0	0	0	0	0	0	0	1
Min. gain	0	0	0	0	0	0	0	X
Power ON	0	0	0	0	0	0	0	1

e) Treble/Bass

	MSB	LSB
Linear	1	0	0	0	1	0	0	0
Max. treble, lin. bass	1	1	0	0	1	0	0	0
Max. treble, lin. bass	1	1	X	X	1	0	0	0
Min. treble, lin. bass	0	1	0	0	1	0	0	0
Min. treble, lin. bass	0	0	X	X	1	0	0	0
Lin. treble, max. bass	1	0	0	0	1	1	0	1
Lin. treble, max. bass	1	0	0	0	1	1	X	1
Lin. treble, max. bass	1	0	0	0	1	1	1	X
Lin. treble, min. bass	1	0	0	0	0	1	0	0
Lin. treble, min. bass	1	0	0	0	0	0	X	X
Max. treble, max. bass	1	1	X	X	1	1	X	1
Min. treble, min. bass	0	0	X	X	0	0	X	X
Power ON	0	0	0	0	0	0	0	1
	MSB			LSB	MSB			LSB
	treble			treble	bass			bass

f) Switch Byte I

MSB	LSB
MUTE I	MUTE II	CH1/CH2 _{LS}	CH1/CH2 _{KH}	Mono	SCART	SCART-D	AM

MUTE I = 0 All AF outputs are muted (speakers, headphones, SCART); power ON

MUTE I = 1 All AF outputs ON

MUTE II = 0 Loudspeaker outputs muted; power ON

MUTE II = 1 Loudspeaker outputs ON

MUTE I and MUTE II are OR gated with respect to the loudspeaker outputs

MUTE I and MUTE III are OR gated with respect to the SCART output

MUTE I	MUTE II	MUTE III	Loudspeaker output	Headphone output	SCART output
0	0	0	muted	muted	muted
0	0	1	muted	muted	muted
0	1	0	muted	muted	muted
0	1	1	muted	muted	muted
1	0	0	muted	ON	muted
1	0	1	muted	ON	ON
1	1	0	ON	ON	muted
1	1	1	ON	ON	ON

CH1/Ch2_{LS} = 0 Sound 1 on the loudspeaker outputs; power ON

Ch1/Ch2_{LS} = 1 Sound 2 on the loudspeaker outputs

Ch1/Ch2_{KH} = 0 Sound 1 on the headphone outputs; power ON

Ch1/Ch2_{KH} = 1 Sound 2 on the headphone outputs

Ch1/Ch2_{LS} and Ch1/Ch2_{KH} are only effective if the matrix is set to the position "dual sound".

Mono = 0 identification signal decoder is set to the position mono and held; power ON

Mono = 1 normal operation if ID-signal decoder

SCART = 0 normal TV operation; power ON

SCART = 1 SCART playback; connection of SCART inputs - AF - outputs
SCART = 1 has priority over AM = 1 (loudspeaker and headphones)

SCART-D = 0 SCART-playback stereo (mono); power ON

SCART-D = 1 Enable for the Ch1/Ch2 switch during SCART playback. (only effective when SCART = 1)

AM = 0 Normal operation (G standard)

AM = 1 AM AF input is activated; power ON
AM = 1 has priority over bypass = 1

Qu-H, Ch1/Ch2_{EN}, Ch1/Ch2_{SC} MUTE III see chapter Control Bytes a.

■ 8235605 0058327 178 ■

g) Switch Byte II

MSB		LSB
MPX0	MPX1	Quasi-st	BS	H-pulse	Matrix 0	Matrix 1	Bypass	
MPX0	MPX1	MPX period		recommended	$C_{25, 26}$	permissible	crystal tolerance	
0	0	2 s	power ON	1 μ F			± 20 ppm	
0	1	4 s		2.2 μ F			± 10 ppm	
1	0	8 s		4.7 μ F			± 5 ppm	
special for crystal operation recommended adjustments:								
0	0	2 s		470 nF			± 40 ppm	
0	1	4 s		330 nF			± 70 ppm	

MPX period = 2 s signifies: ID-signal decoder searches 1 second dual and 1 second stereo
 It is in principle permitted to make with given $C_{25, 26}$ the MPX-period higher than indicated, but not lower.

MPX period = 2 s signifies: ID-signal decoder searches 1 s dual and 1 s stereo

Quasi stereo = 0 Quasi stereo OFF; power ON
 Quasi stereo = 1 Quasi stereo ON
 Bb = 0 Stereo base width expansion OFF; power ON
 Bb = 1 Stereo base width expansion ON;

H-pulse = 0 ID-signal decoder synchronization with $f_H = 15.625$ kHz; power ON
 H-pulse = 1 ID synchronization with $4 \times f_H$
 (has to be set to 1 during operation with crystal or 4-MHz reference frequency)

Matrix 0 Matrix1 Matrix status
 0 0 mono power ON
 0 1 stereo
 1 0 dual
 1 1 automatic according to ID-signal decoder

Bypass = 0 Normal operations (G standard)
 Bypass = 1 Matrix is bridge so that left/right signals can be fed; power ON
 (AM = 1 has priority over bypass = 1)

Priority List of Setting Bits

1. MUTE I
2. MUTE II (only with regard to the loudspeaker output)
3. SCART
4. AM
5. Bypass
6. Matrix 0, 1

h) Talk Mode

MS	•	•	•	•	•	•	LSB
St	D	T3	T4	T5	CL	X	X
0	0	decoder detects mono					
1	0	decoder detects stereo					
0	1	decoder detects dual					
1	1	internally inhibited					
CL = 1	The signal path for the loudspeaker reached the clipping level (The bit CL is automatical reset)						

T3 - T5 are test bits

Pin Functions

Pin No.	Function
1	AF-input mono, left, sound 1 (may be balanced)
2	Bias for F operating point
3	AF-input right, sound 2
4	54-kHz input
5	54-kHz filter
6	AF-input (L-standard)
7	AF-input SCART left (sound 1)
8	AF-input SCART right (sound 2)
9	AF-output SCART (mono, sound 1, left)
10	AF-output SCART (mono, sound 2, right)
11	Phase shifter quasi stereo
12	Phase shifter quasi stereo
13	Cut-off frequency bass (base width) left
14	Cut-off frequency bass (base width) right
15	AF-output, loudspeaker right
16	AF-output, loudspeaker left
17	Cut-off frequency treble left
18	Cut-off frequency treble right
19	AF-output, headphones right
20	AF-output, headphones left
21	+ V_S (supply voltage)
22	I ² C Bus SCL
23	I ² C Bus SDA
24	Input H-pulse (4 x H-pulse), crystal oscillator
25	Filter ID-signal decoder
26	Filter ID-signal decoder
27	PLL filter ID-signal decoder
28	Ground

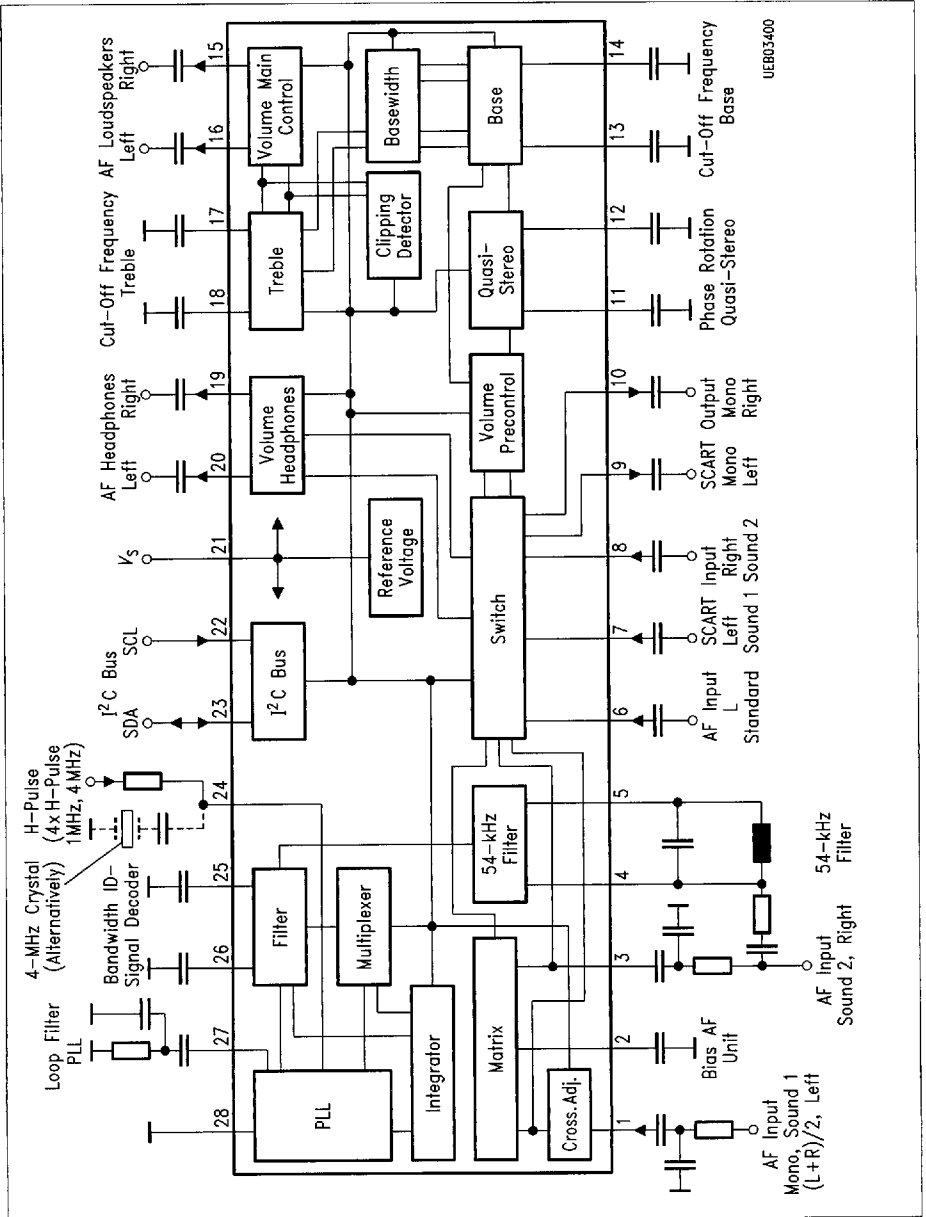

Block Diagram

8235605 0058331 6T9

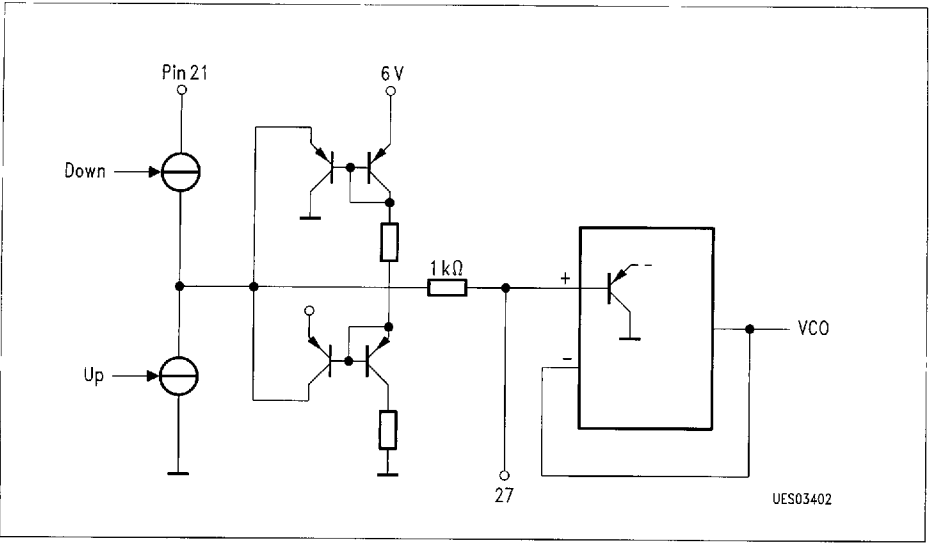

PLL Filter ID-Signal Decoder

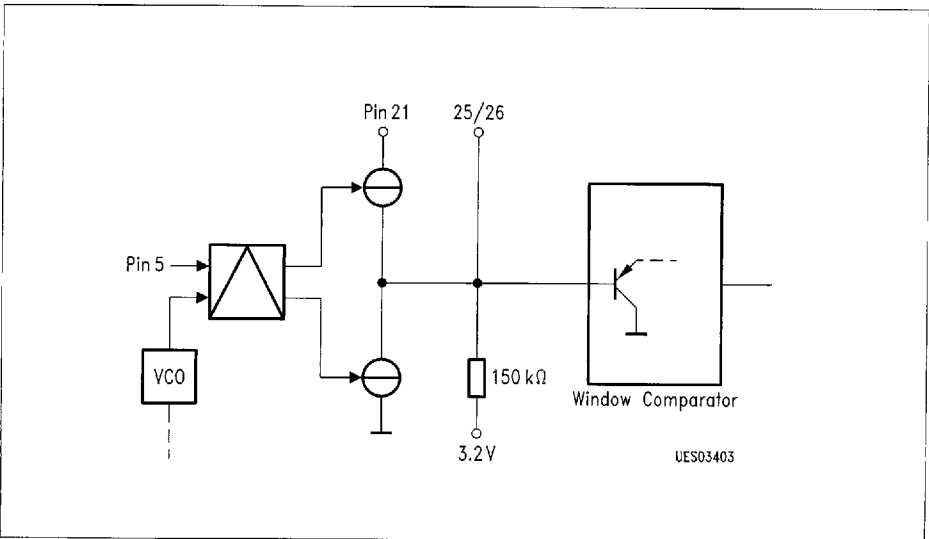

Filter ID-Signal Decoder (Pin 25/26)

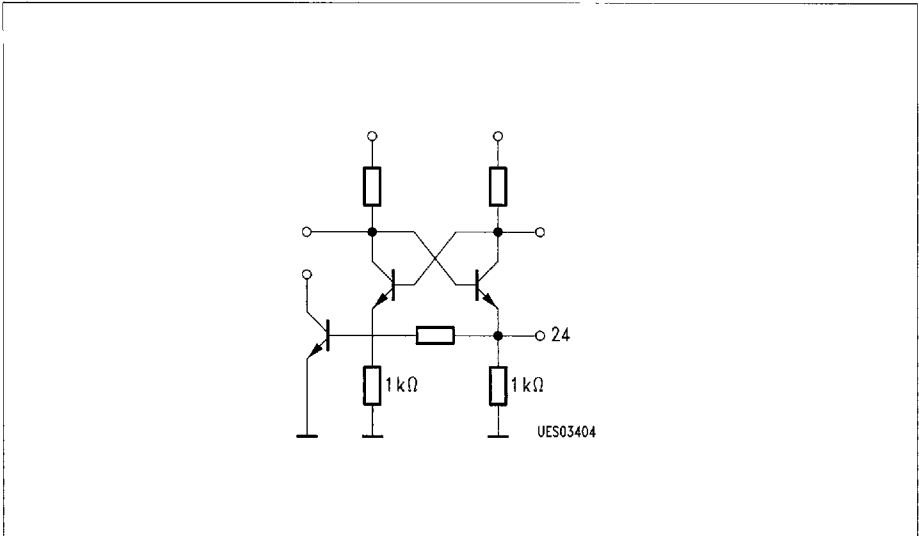

H-Pulse/Crystal Oscillator (Pin 24)

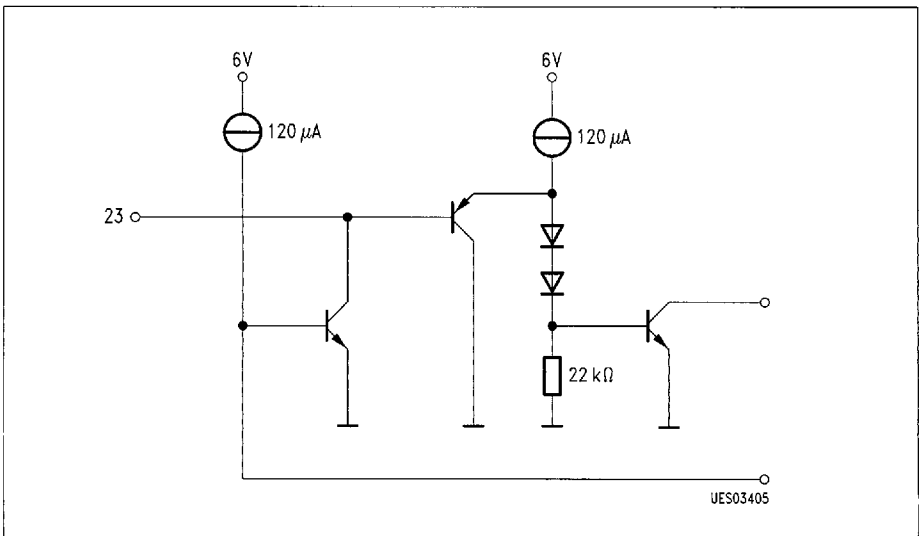

I²C Bus SDA (Pin 23)

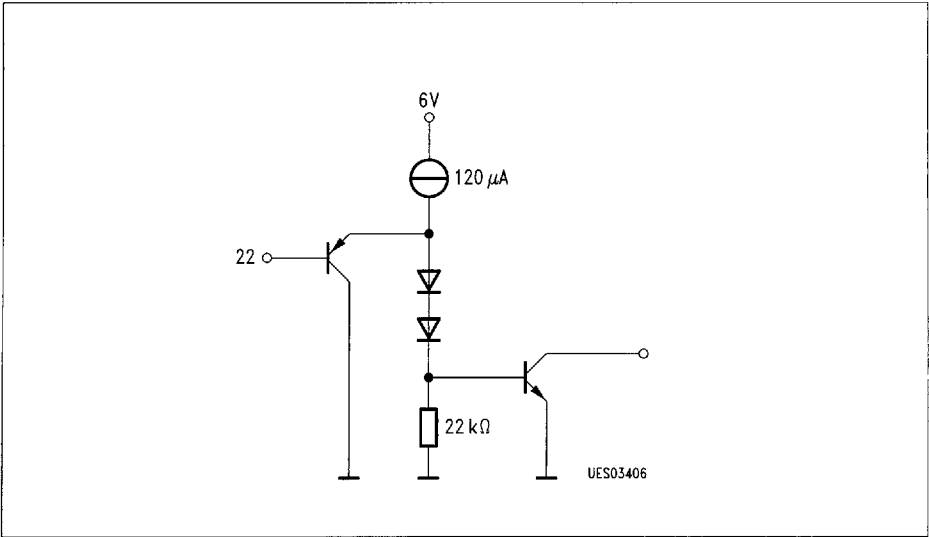

I²C Bus SCL (Pin 22)

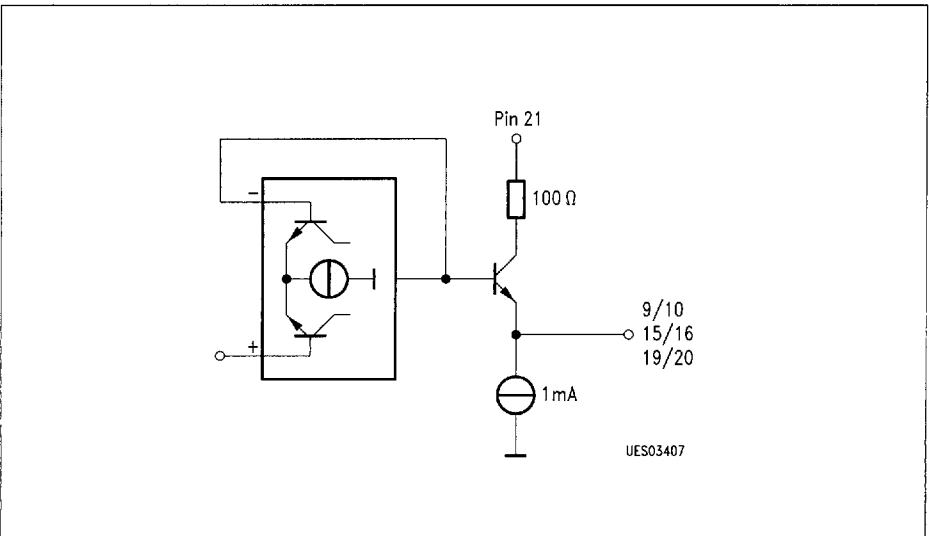

AF Outputs Headphones (Pin 19/20)
Loudspeaker (Pin 15/16)
SCART (Pin 9/10)

■ 8235605 0058334 308 ■

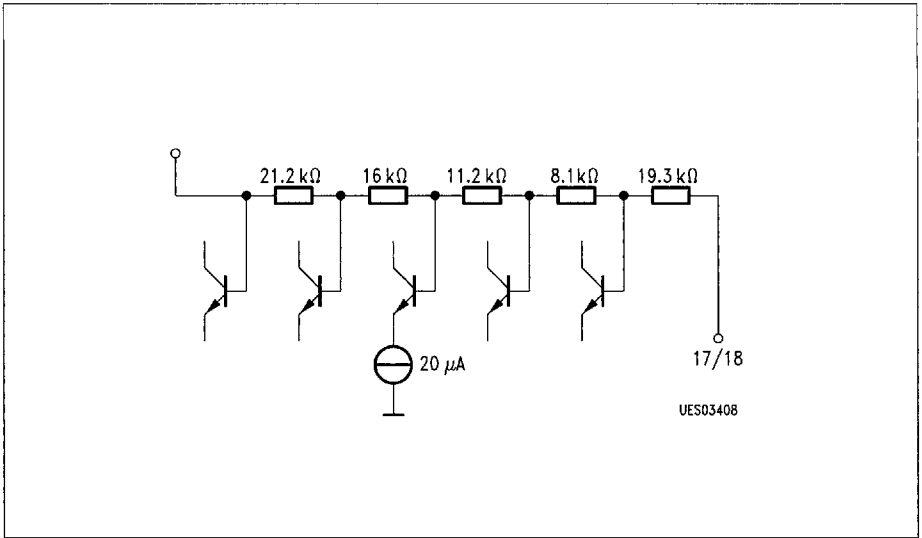

Cut-off Frequency Treble (Pin 17/18)

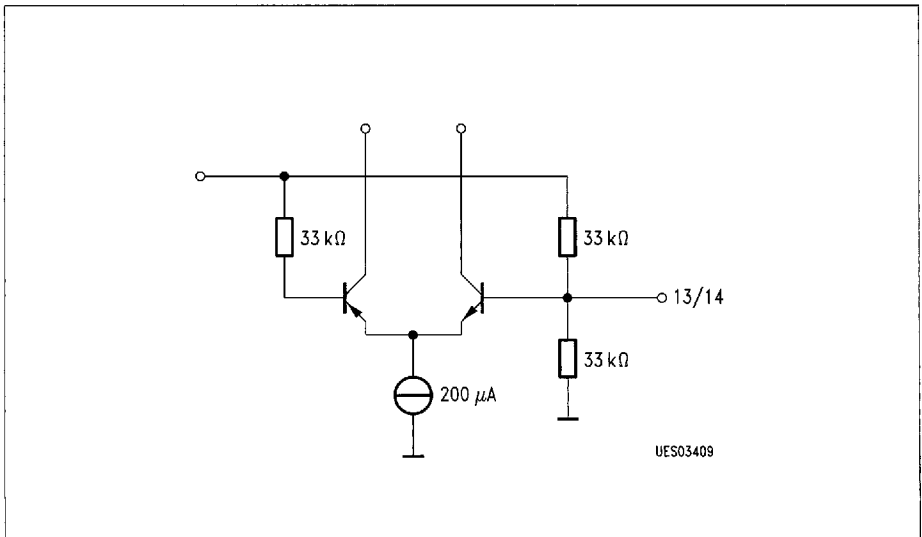

Cut-off Frequency Bass (Pin 13/14)

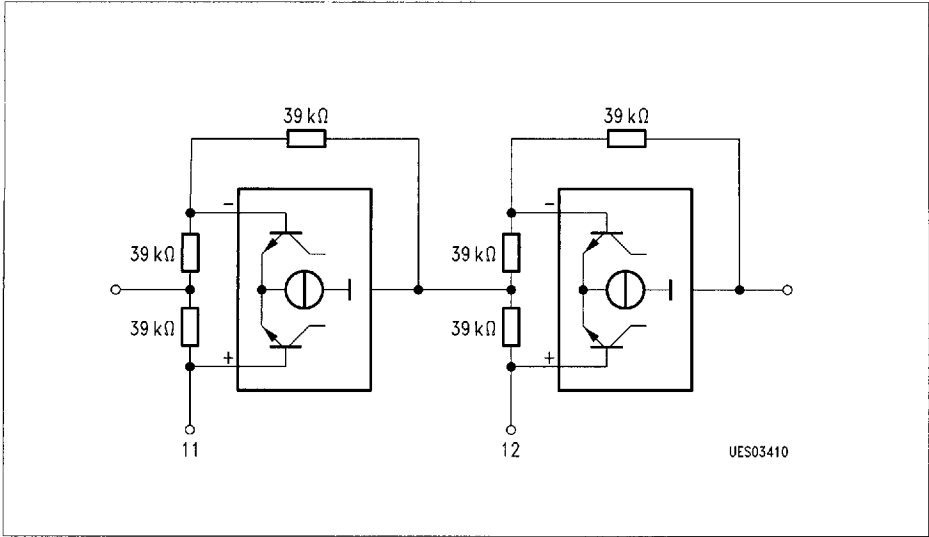

Phase Advancer Quasi Stereo (Pin 11/12)

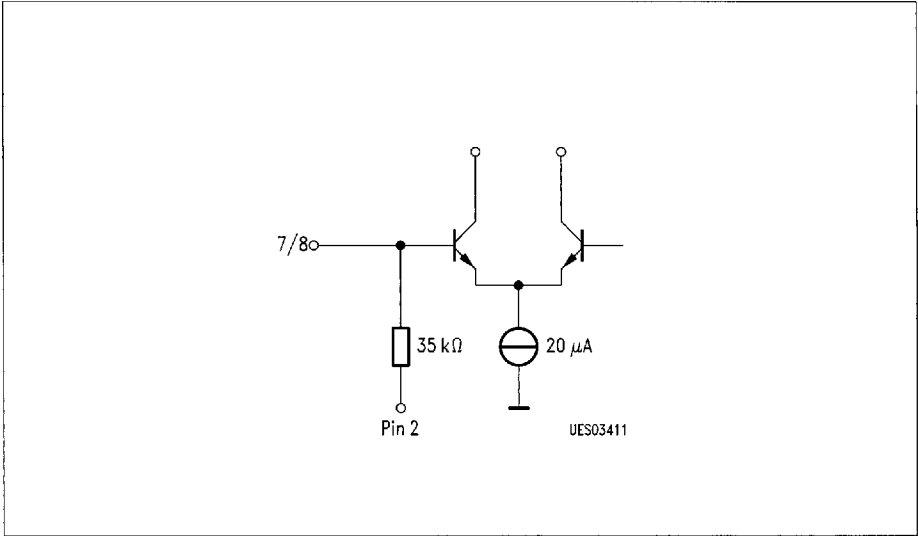

AF Inputs SCART (Pin 7/8)

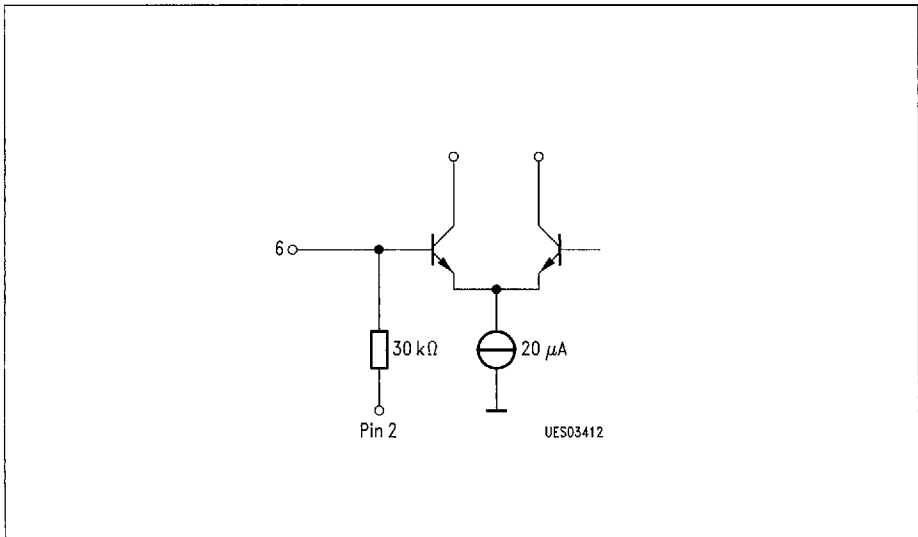

AF Input AM (Pin 6)

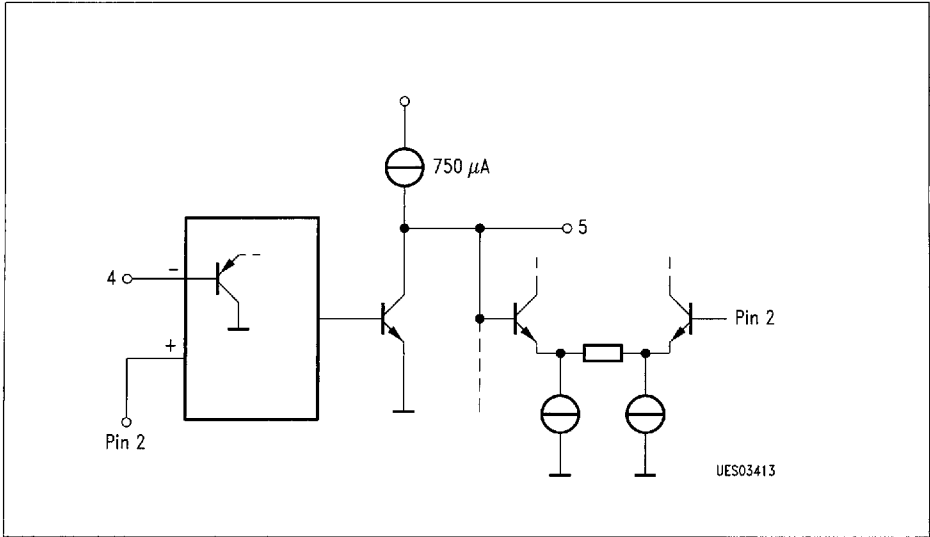

54-kHz Filter (Pin 4/5)

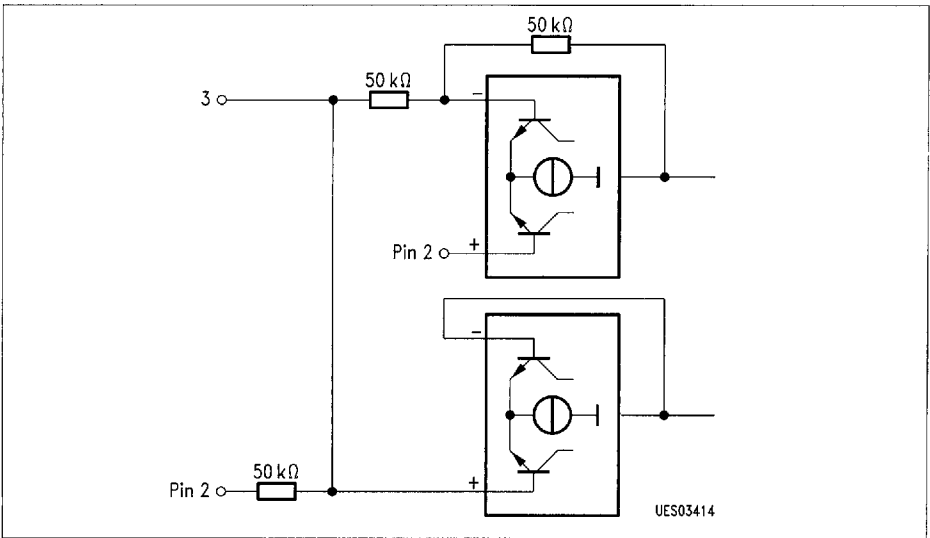

AF Input (Pin 3)

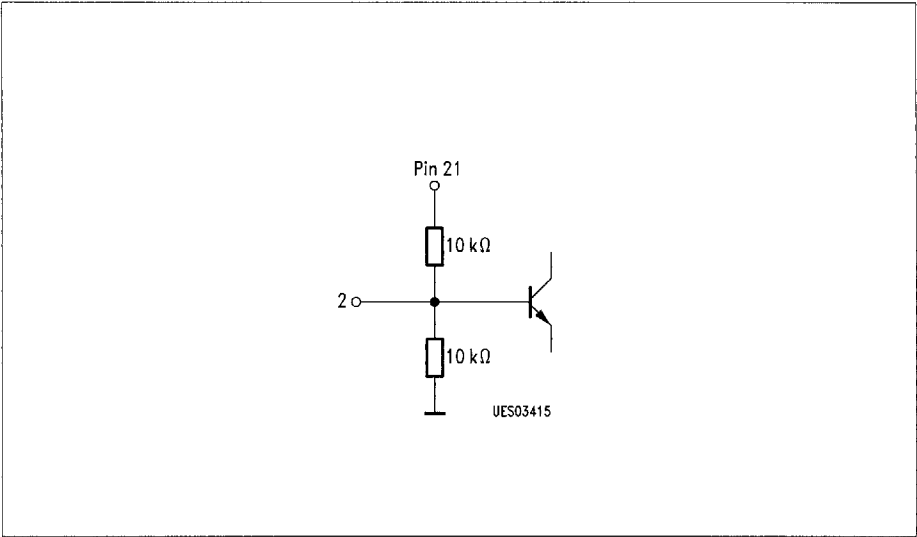

Input for AF Unit Bias Blocking Capacitor (Pin 2)

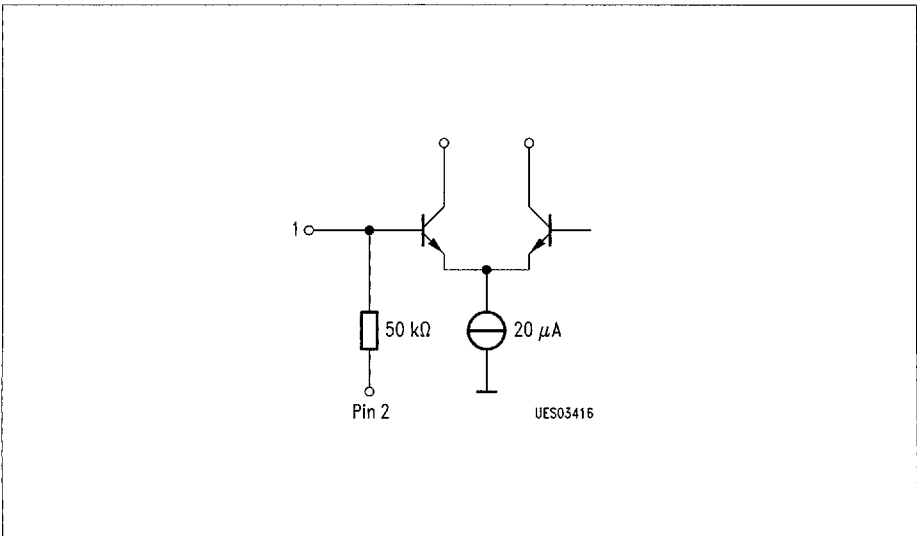

AF Input (Pin 1)

Absolute Maximum Ratings

$T_A = 0$ to 70 °C; all voltages relatives to V_{SS}

Parameter	Symbol	Limit Values		Unit	Remarks
		min.	max.		
Supply voltage	V_{21}	0	14	V	
Max. DC-voltage	V_1	0	V_{21}	V	
Max. DC-voltage	V_2	0	V_{21}	V	
Max. DC-voltage	V_3	0	V_{21}	V	
Max. DC-voltage	V_4	0	V_{21}	V	
Max. DC-voltage	V_6	0	V_{21}	V	
Max. DC-voltage	V_7	0	V_{21}	V	
Max. DC-voltage	V_8	0	V_{21}	V	
Max. DC-voltage	V_{11}	0	V_{21}	V	
Max. DC-voltage	V_{12}	0	V_{21}	V	
Max. DC-voltage	V_{13}	0	V_{21}	V	
Max. DC-voltage	V_{14}	0	V_{21}	V	
Max. DC-voltage	V_{17}	0	V_{21}	V	
Max. DC-voltage	V_{18}	0	V_{21}	V	
Max. DC-voltage	V_{22}	0	V_{21}	V	
Max. DC-voltage	V_{23}	0	V_{21}	V	
Max. DC-voltage	V_{24}	0	V_{21}	V	
Max. DC-voltage	V_{25}	0	V_{21}	V	
Max. DC-voltage	V_{26}	0	V_{21}	V	
Max. DC-current	I_5	0	2	mA	
Max. DC-current	I_9	0	2	mA	
Max. DC-current	I_{10}	0	2	mA	
Max. DC-current	I_{15}	0	2	mA	
Max. DC-current	I_{16}	0	2	mA	
Max. DC-current	I_{19}	0	2	mA	
Max. DC-current	I_{20}	0	2	mA	
Max. DC-current	I_{27}	0	1	mA	

Absolute Maximum Ratings (cont'd)

Parameter	Symbol	Limit Values		Unit	Remarks
		min.	max.		
ESD-voltage	V_{ESD}	-2	2	kV	HBM ($R = 1.5 \text{ k}\Omega$, $C = 100 \text{ pF}$)
ESD-voltage	$V_{ESD7,8,9,10}$	-6	6	kV	HBM ($R = 1.5 \text{ k}\Omega$, $C = 100 \text{ pF}$)
Junction temperature	T_j		150	°C	
Storage temperature	T_{stg}	-40	125	°C	
Thermal resistance system ambient	$R_{th SA}$		53	K/W	

Operating Range

Supply voltage	V_6	10	13.2	V	
Ambiente temperature	T_A	0	70	°C	
Input frequency range	f_I	0.01	20	kHz	

Characteristics

$V_S = 12\text{ V}$; $T_A = 25\text{ }^\circ\text{C}$, audio reference level 0 dB–250 mVrms, if not differently defined; in accordance with test circuit 1

I²C Bus present: start - 84 - 01,3F - 0 2,3F - 04,00 - 0 3,1F - 0 5,88 - 0 6,10 - 07,C8 - 00,01 - stop

Chip address - *Vol_{LSI} 63 - Vol_{LSr} 63 - Vol_{VLs} - Vol_{HP} 31 - Sound lin Adjust 0dB - MUTE I, MUTE II, Mono - Bypass*

The basic setting for each point in the specification is always present; only settings which deviate from this are given in the test conditions. Details in *italics* only provide explanation of the hexadecimal codes. If switch byte are mentioned only the bit status and activated features are indicated.

Parameter	Symbol	Limit Values			Unit	Test Condition
		min.	typ.	max.		
Current consumption	I_{21}		55	80	mA	

Signal Section

Max. gain	V_{16-1}	-2	0	2	dB	
Max. gain	V_{15-3}	-2	0	2	dB	
Max. gain	V_{20-1}	-2	0	2	dB	
Max. gain	V_{19-3}	-2	0	2	dB	
Max. gain	V_{16-3}	-2	0	2	dB	00,02; $V_1 = 01$ <i>Matrix: Stereo</i>
Max. gain	V_{15-3}	-2	0	2	dB	00,02; $V_1 = 01$ <i>Matrix: Stereo</i>
Max. gain	V_{20-3}	-2	0	2	dB	00,02; $V_1 = 0$ <i>Matrix: Stereo</i>
Max. gain	V_{19-3}	-2	0	2	dB	00,02; $V_1 = 0$ <i>Matrix: Stereo</i>
Max. gain	V_{16-1}	4	6	8	dB	00,02; $V_3 = 0$ <i>Matrix: Stereo</i>
Max. gain	V_{20-1}	4	6	8	dB	00,02; $V_3 = 0$ <i>Matrix: Stereo</i>
Max. gain	V_{16-7}	-2	0	2	dB	07,CC, SCART
Max. gain	V_{15-8}	-2	0	2	dB	07,CC, SCART
Max. gain	V_{20-7}	-2	0	2	dB	07,CC, SCART
Max. gain	V_{19-8}	-2	0	2	dB	07,CC, SCART
Max. gain	V_{16-6}	-2	0	2	dB	07,C9, AM
Max. gain	V_{15-6}	-2	0	2	dB	07,C9, AM
Max. gain	V_{20-6}	-2	0	2	dB	07,C9, AM
Max. gain	V_{19-6}	-2	0	2	dB	07,C9, AM

Characteristics (cont'd)

Parameter	Symbol	Limit Values			Unit	Test Condition
		min.	typ.	max.		
Gain	V_{9-1}	-2	0	2	dB	
Gain	V_{10-3}	-2	0	2	dB	
Gain	V_{9-3}	-2	0	2	dB	
Gain	V_{10-3}	-2	0	2	dB	00,02; $V_1 = 0$ <i>Matrix: Stereo</i>
Gain	V_{9-1}	4	6	8	dB	00,02; $V_1 = 0$ <i>Matrix: Stereo</i>
Gain	V_{10-6}	-2	0	2	dB	00,02; $V_1 = 0$ <i>Matrix: Stereo</i>
Gain	V_{9-6}	-2	0	2	dB	07,C9, AM
Min. gain Main control	V_{16-1}		-70	-65	dB	01,08-02,08 $Vol_{LS} 8 - Vol_{LSr} 8$
Min. gain Main control	V_{15-3}		-70	-65	dB	01,08-02,08 $Vol_{LS} 8 - Vol_{LSr} 8$
Min. gain 1st. control	V_{16-1}	-17	-15	-13	dB	04,18 $Vol_{VLS} 24$
Min. gain 1st. control	V_{15-3}	-17	-15	-13	dB	04,18 $Vol_{VLS} 24$
Min. gain	V_{20-1}		-62	-57	dB	03,01, $Vol_{HP} 1$
Min. gain	V_{19-3}		-62	-57	dB	03,01, $Vol_{HP} 1$

Characteristics (cont'd)

Parameter	Symbol	Limit Values			Unit	Test Condition
		min.	typ.	max.		
Analogous values are valid for feed in at the pins 6, 7 and 8						
Channel tracking error	ΔV_{15-16}			± 2	dB	01,3F to 01,24 02,3F to 02,24 $Vol_{LSI} 63-36 - Vol_{LSr} 63-36$
Channel tracking error	ΔV_{19-26}			± 2	dB	03,1F to 03,13 $Vol_{HP} 31-19$
Step width Vol ₁₅	ΔV_{15}	0	1.25	2.5	dB	01,X-01,(X ± 1) $Vol_{LSI} X - Vol_{LSI} (X 1)$
Step width Vol ₁₆	ΔV_{16}	0	1.25	2.5	dB	02,X-02,(X ± 1) $Vol_{LSr} X - Vol_{LSr} (X 1)$
Step width Vol ₁₅	ΔV_{15}	0	1.25	2.5	dB	04,X-04,(X ± 1) $Vol_{VLS} X - Vol_{VLS} (X 1)$
Step width Vol ₁₆	ΔV_{16}	0	1.25	2.5	dB	04,X-04,(X ± 1) $Vol_{VLS} X - Vol_{VLS} (X 1)$
Step width Vol ₁₉	ΔV_{19}	0	2	4	dB	03,X-03,(X ± 1) $Vol_{HP} X - Vol_{HP} (X 1)$
Step width Vol ₂₀	ΔV_{20}	0	2	4	dB	03,X-03,(X ± 1) $Vol_{HP} X - Vol_{HP} (X 1)$
Matrix adjustment	V_{16-1}	2.5	3	3.5	dB	06,1F, <i>Adjust. max</i>
Matrix adjustment	V_{20-1}	2.5	3	3.5	dB	06,1F, <i>Adjust. max</i>
Matrix adjustment	V_{9-1}	2.5	3	3.5	dB	06,1F, <i>Adjust. max</i>
Matrix adjustment	V_{16-1}	-3.5	-3	-2.5	dB	06,01, <i>Adjust. min</i>
Matrix adjustment	V_{20-1}	-3.5	-3	-2.5	dB	06,01, <i>Adjust. min</i>
Matrix adjustment	V_{9-1}	-3.5	-3	-2.5	dB	06,1F, <i>Adjust. max</i>
Adjust. step width	ΔV_{16}	0.1	0.2	0.3	dB	06,X-06,(X ± 1) <i>Adjust. X - adjust. (X 1)</i>

Characteristics (cont'd)

Parameter	Symbol	Limit Values			Unit	Test Condition
		min.	typ.	max.		
Adjust. step width	ΔV_{20}	0.1	0.2	0.3	dB	06,X-06,(X ± 1) <i>Adjust. X – adjust. (X ± 1)</i>
Adjust. step width	ΔV_9	0.1	0.2	0.3	dB	06,X-06,(X ± 1) <i>Adjust. X – adjust. (X ± 1)</i>
Bass boost	V_{16-1}	13	15		dB	05,8 F; $f_1 = 40$ Hz <i>Bass max, treble lin.</i>
Bass boost	V_{15-3}	13	15		dB	05,8 F; $f_1 = 40$ Hz <i>Bass max, treble lin.</i>
Bass cut	V_{16-1}		-12		dB	05,8 F; $f_1 = 40$ Hz <i>Bass max, treble lin.</i>
Bass cut	V_{15-3}		-12		dB	05,8 F; $f_1 = 40$ Hz <i>Bass max, treble lin.</i>
Step width bass	ΔV_{15}	1	3	5	dB	05,8X-05,8 (X ± 1) <i>Bass X – bass (X ± 1)</i>
Step width bass	ΔV_{16}	1	3	5	dB	05,8X-05,8 (X ± 1) <i>Bass X – bass (X ± 1)</i>

Characteristics (cont'd)

Parameter	Symbol	Limit Values			Unit	Test Condition
		min.	typ.	max.		
Treble boost	V_{16-1}	10	12		dB	05,8 F; $f_1 = 15$ Hz <i>Treble max, bass lin.</i>
Treble boost	V_{15-3}	10	12		dB	05,8 F; $f_1 = 15$ Hz <i>Treble max, bass lin.</i>
Treble cut	V_{16-1}		-12		dB	05,8 F; $f_1 = 15$ Hz <i>Treble max, bass lin.</i>
Treble cut	V_{15-3}		-12		dB	05,8 F; $f_1 = 15$ Hz <i>Treble max, bass lin.</i>
Step width bass	ΔV_{15}	1	3	5	dB	05,X8-05 ($X \pm 1$)8 <i>Treble X - treble (X 1)</i>
Step width bass	ΔV_{16}	1	3	5	dB	05,X8-05 ($X \pm 1$)8 <i>Treble X - treble (X 1)</i>
Linearity sound	ΔV_{15}			± 2	dB	05,88; $f_1 = 40$ Hz - 15 kHz <i>Treble, bass lin.</i>
Linearity sound	ΔV_{16}			± 2	dB	05,88; $f_1 = 40$ Hz - 15 kHz <i>Treble, bass lin.</i>
Detection level of the clipping detector	V_1		580		mVrms	05,8 F; $f_1 = 40$ Hz <i>Treble lin, bass max.</i> 01,2F - 02,2F $Vol_{LS1} 47 - Vol_{LSr} 47$

The same values are valid if the test signals are applied at pin 3, 6, 7 or 8

Channel separation	ΔV_{15-16}	50			dB	V_3 or $V_8 = 600$ mVrms
Channel separation of the clipping	ΔV_{19-20}	50			dB	V_3 or $V_8 = 600$ mVrms
Channel separation	ΔV_{9-10}	50			dB	V_3 or $V_8 = 600$ mVrms
Cross talk attenuation switch	$\alpha_{1 \text{ Interf. / Q rms}}$	60			dB	$V_{1 \text{ rms}} = 0$ $V_{1 \text{ Interf., 3,6}} = 600$ mVrms $V_{1 \text{ Interf., 7,8}} = 2$ Vrms

Characteristics (cont'd)

Parameter	Symbol	Limit Values			Unit	Test Condition
		min.	typ.	max.		
Attenuation MUTE	α_{1-16}	80			dB	01,00 - 02,00 <i>Vol_{LSI} 0 - Vol_{LSr} 0</i> <i>V₁ = 600 mVrms</i>
Attenuation MUTE	α_{1-16}	80			dB	07,48; <i>V₁ = 600 mVrms</i> <i>MUTE I: 0</i>
Attenuation MUTE	α_{1-16}	80			dB	07,88; <i>V₁ = 600 mVrms</i> <i>MUTE II: 0</i>
Attenuation MUTE	α_{3-15}	80			dB	01,00 - 02,00 <i>Vol_{LSI} 0 - Vol_{LSr} 0</i> <i>V₃ = 600 mVrms</i>
Attenuation MUTE	α_{3-15}	80			dB	07,48; <i>V₃ = 600 mVrms</i> <i>MUTE I: 0</i>
Attenuation MUTE	α_{3-15}	80			dB	07,88; <i>V₃ = 600 mVrms</i> <i>MUTE II: 0</i>
Attenuation MUTE	α_{1-20}	80			dB	03,00; <i>V₁ = 600 mVrms</i> <i>Vol_{HP} 0</i>
Attenuation MUTE	α_{1-20}	80			dB	07,48; <i>V₁ = 600 mVrms</i> <i>MUTE I: 0</i>

Characteristics (cont'd)

Parameter	Symbol	Limit Values			Unit	Test Condition
		min.	typ.	max.		
Attenuation MUTE	α_{3-19}	80			dB	03,00; $V_3 = 600$ mVrms MUTE I: 0
Attenuation MUTE	α_{3-19}	80			dB	07,48; $V_1 = 600$ mVrms MUTE I: 0
Analogous values are valid for feed in at pins 6, 7, 8; $V_{7,8} = 2$ Vrms; $V_6 = 600$ mVrms						
Attenuation MUTE	α_{3-10}	80			dB	07,48; $V_3 = 600$ mVrms MUTE I: 0
Attenuation MUTE	α_{1-9}	80			dB	07,48; $V_1 = 600$ mVrms MUTE I: 0
Attenuation MUTE	α_{6-10}	80				07,49; $V_6 = 600$ mVrms MUTE I: 0, AM
Attenuation MUTE	α_{6-9}	80				07,49; $V_6 = 600$ mVrms MUTE I: 0, AM
Max. input voltage	V_6	600			mVrms	THD _{15,16} = 1%
Max. input voltage	V_3	600			mVrms	THD ₁₅ = 1%
Max. input voltage	V_3	600			mVrms	THD ₁₆ = 1%
Max. input voltage	V_1	300			mVrms	THD ₁₆ = 1%; 00,02 Matrix; Stereo
Max. input voltage*)	V_7	2			Vrms	THD ₁₆ = 3%; 07, CC, Scart
Max. input voltage*)	V_8	2			Vrms	THD ₁₅ = 1%; 07, CC, Scart

*) The tone control is possible over the full functional range if 04, 18, Vol_{VLS} 24

Characteristics (cont'd)

Parameter	Symbol	Limit Values			Unit	Test Condition
		min.	typ.	max.		
Distortion	THD_{19}		0.01	0.1	%	$V_3 = 250$ mVrms
Distortion	THD_{20}		0.01	0.1	%	$V_1 = 250$ mVrms
Distortion	THD_{19}		0.01	0.1	%	$V_3 = 250$ mVrms; 03,15 Vol _{HP} 21
Distortion	THD_{20}		0.01	0.1	%	$V_3 = 250$ mVrms; 03,15 Vol _{HP} 21
Analogous values are valid for feed in at pins 6, 7, 8; $V_{7,8} = 600$ Vrms; $V_6 = 250$ mVrms						
Distortion	THD_{16}		0.01	0.1	%	$V_1 = 250$ mVrms;
Distortion	THD_{15}		0.01	0.1	%	$V_3 = 250$ mVrms
Distortion	THD_{15}		0.01	0.2	%	$V_1 = 250$ mVrms; 01,2F-02,2F Vol _{LSI} 47 Vol _{LSr} 47
Distortion	THD_{15}		0.01	0.2	%	$V_3 = 250$ mVrms; 01,2F-02,2F Vol _{LSI} 47 Vol _{LSr} 47
Distortion	THD_{16}		0.1	0.4	%	$V_1 = 250$ mVrms; 05,XX any sound
Distortion	THD_{15}		0.1	0.4	%	$V_3 = 250$ mVrms; 05,XX any sound
Analogous values are valid for feed in at pins 6, 7, 8; $V_{7,8} = 600$ mVrms; $V_6 = 250$ mVrms						
Distortion	THD_{10}		0.01	0.1	%	$V_3 = 250$ mVrms
Distortion	THD_9		0.01	0.1	%	$V_1 = 250$ mVrms
Distortion	THD_{10}		0.01	0.1	%	$V_6 = 250$ mVrms; 07,C9,AM
Distortion	THD_9		0.01	0.1	%	$V_6 = 250$ mVrms; 07,C9,AM

Characteristics (cont'd)

Parameter	Symbol	Limit Values			Unit	Test Condition
		min.	typ.	max.		
Anti-phase cross talk Base width	ΔV_{16-15}	0.5	0.55			$V_3 = 600 \text{ mVrms}$ $f_1 = 2 \text{ kHz}; 00, 11$ <i>Base width</i>
Anti-phase cross talk Base width	ΔV_{15-16}	0.5	0.55			$V_1 = 600 \text{ mVrms}$ $f_1 = 2 \text{ kHz}; 00, 11$ <i>Base width</i>
Base width phase	Φ_{16-15}	150	180	210	deg	$V_1 = 600 \text{ mVrms}$ $f = 2 \text{ kHz}; 00, 11$ <i>Base width</i>
Base width phase	Φ_{15-16}	150	180	210	deg	$V_3 = 600 \text{ mVrms}$ $f = 2 \text{ kHz}; 00, 11$ <i>Base width</i>
Phase rotation quasi stereo	Φ_{16-15}	0	10	40	deg	$V_{3,1} = 600 \text{ mVrms}$ $f = 40 \text{ kHz}; 00, 21$ <i>Quasi stereo</i>
Phase rotation quasi stereo	Φ_{16-15}	130	180	230	deg	$V_{3,1} = 600 \text{ mVrms}$ $f = 700 \text{ kHz}; 00, 21$ <i>Quasi stereo</i>
Phase rotation quasi stereo	Φ_{16-15}	-30	10	0	deg	$V_{3,1} = 600 \text{ mVrms}$ $f = 15 \text{ kHz}; 00, 21$ <i>Quasi stereo</i>
Signal-to-noise ratio	$\alpha_{S/N16}$	90	97		dB	$V_{N \text{ rms } 20 \text{ Hz-20 kHz}}$ $V_1 = 0.6 \text{ Vrms}$
Signal-to-noise ratio	$\alpha_{S/N15}$	90	97		dB	$V_{N \text{ rms } 20 \text{ Hz-20 kHz}}$ $V_3 = 0.6 \text{ Vrms}$
Signal-to-noise ratio	$\alpha_{S/N16}$	70	80		dB	$V_{N \text{ rms } 20 \text{ Hz-20 kHz}}$ $V_1 = 0.6 \text{ Vrms}$ 01,27-02,27 $Vol_{LSI} 39 - Vol_{LSr} 39$
Signal-to-noise ratio	$\alpha_{S/N15}$	70	80		dB	$V_{N \text{ rms } 20 \text{ Hz-20 kHz}}$ $V_3 = 0.6 \text{ Vrms}$ 01,27-02,27 $Vol_{LSI} 39 - Vol_{LSr} 39$

Characteristics (cont'd)

Parameter	Symbol	Limit Values			Unit	Test Condition
		min.	typ.	max.		
Output noise voltage	V_{N16}		2	10	μVrms	$V_{N \text{ rms } 20 \text{ Hz-20 kHz; } 01,00-02,00}$ $Vol_{LSI} 0-Vol_{LSr} 0$
Output noise voltage	V_{N15}		2	10	μVrms	$V_{N \text{ rms } 20 \text{ Hz-20 kHz; } 01,00-02,00}$ $Vol_{LSI} 0-Vol_{LSr} 0$
Signal-to-noise ratio	$\alpha_{S/N20}$	90	97		dB	$V_{N \text{ rms } 20 \text{ Hz-20 kHz; } V_1 = 0.6 \text{ Vrms}}$
Signal-to-noise ratio	$\alpha_{S/N19}$	90	97		dB	$V_{N \text{ rms } 20 \text{ Hz-20 kHz; } V_3 = 0.6 \text{ Vrms}}$
Signal-to-noise ratio	$\alpha_{S/N20}$	70	80		dB	$V_{N \text{ rms } 20 \text{ Hz-20 kHz; } V_1 = 0.6 \text{ Vrms}}$ 03, 10, $Vol_{HP} 16$
Signal-to-noise ratio	$\alpha_{S/N19}$	70	80		dB	$V_{N \text{ rms } 20 \text{ Hz-20 kHz; } V_3 = 0.6 \text{ Vrms}}$ 03, 10, $Vol_{HP} 16$
Output noise voltage	V_{N20}		2	10	μVrms	$V_{N \text{ rms } 20 \text{ Hz-20 kHz; } 03, 00, Vol_{HP} 0}$
Output noise voltage	V_{N19}		2	10	μVrms	$V_{N \text{ rms } 20 \text{ Hz-20 kHz; } 03, 00, Vol_{HP} 0}$
Signal-to-noise ratio	$\alpha_{S/N9}$	90	97		dB	$V_{N \text{ rms } 20 \text{ Hz-20 kHz; } V_1 = 0.6 \text{ Vrms}}$
Signal-to-noise ratio	$\alpha_{S/N10}$	90	97		dB	$V_{N \text{ rms } 20 \text{ Hz-20 kHz; } V_1 = 0.6 \text{ Vrms}}$

Characteristics (cont'd)

Parameter	Symbol	Limit Values			Unit	Test Condition
		min.	typ.	max.		
DC/pop Δ1 Bit	ΔV_{16}			±10	mV	01, X-01, X ± 1 $Vol_{LSI} X - Vol_{LSI} (X \pm 1)$
DC/pop Δ1 Bit	ΔV_{15}			±10	mV	02, X-02, X ± 1 $Vol_{LSr} X - Vol_{LSr} (X \pm 1)$
DC/pop Δ1 Bit	ΔV_{16}			±10	mV	04, X-04, X ± 1 $Vol_{VLS} X - Vol_{VLS} (X \pm 1)$
DC/pop Δ1 Bit	ΔV_{15}			±10	mV	04, X-04, X ± 1 $Vol_{VLS} X - Vol_{VLS} (X \pm 1)$
DC/pop Δ1 Bit	ΔV_{16}			±10	mV	05, X-05, X ± 1 $ToneX - Tone (X \pm 1)$
DC/pop Δ1 Bit	ΔV_{15}			±10	mV	05, X-05, X ± 1 $ToneX - Tone (X \pm 1)$
DC/pop Δ1 Bit	ΔV_{19}			±10	mV	03, X-03, X ± 1 $Vol_{HP} X - Vol_{HP} (X \pm 1)$
DC/pop Δ1 Bit	ΔV_{20}			±10	mV	03, X-03, X ± 1 $Vol_{HP} X - Vol_{HP} (X \pm 1)$

Design-Related Data

Input resistance	R_7	35			kΩ	
Input resistance	R_8	35			kΩ	
Input resistance	R_6	20			kΩ	
Input resistance	R_3	40			kΩ	
Input resistance	R_1	40			kΩ	
Output resistance	R_{19}			200	Ω	
Output resistance	R_{20}			200	Ω	
Output resistance	R_{15}			60	Ω	
Output resistance	R_{16}			60	Ω	
Output resistance	R_9			60	Ω	
Output resistance	R_{10}			60	Ω	

Characteristics (cont'd)

Parameter	Symbol	Limit Values			Unit	Test Condition	Test Circuit
		min.	typ.	max.			
ID-Signal Decoder							
Gain filter OP-amplif.	V_5	13	14	15	dB	$V_{IF} = 80 \text{ mVpp}$	1
Max. input voltage	V_5	600			mVpp	Function	2
VCO voltage PLL	V_{27}	1.3			V	$f_{24} = 14.6 \text{ kHz};$ $V_{24} = 2.5 \text{ V}$	2
VCO voltage PLL	V_{27}	2	3	4	V	$f_{24} = 15.625 \text{ kHz};$ $V_{24} = 2.5 \text{ V}$	2
VCO voltage PLL	V_{27}			4.7	V	$f_{24} = 16.6 \text{ kHz};$ $V_{24} = 2.5 \text{ V}$	2
VCO voltage PLL	V_{27}	1.3			V	$f_{24} = 58.4 \text{ kHz};$ $V_{24} = 2.5 \text{ V}$ 00,08, H-pulse	2
VCO voltage PLL	V_{27}	2	3	4.7	V	$f_{24} = 66.4 \text{ kHz};$ $V_{24} = 2.5 \text{ V}$ 00,08, H-pulse	2
VCO voltage PLL	V_{27}				V	00,08 - 04.81 H-pulse; quartz cont. function	4

$$V_{\text{Filter gain}} = \frac{\sqrt{(V_{25} - V_{25}^*)^2 + (V_{26} - V_{26}^*)^2}}{V_5} \begin{matrix} V_{25} \text{ or } V_{26} \text{ when } V_5 = 0 \\ V_{25}^* \text{ or } V_{26}^* \text{ when } V_5 = 100 \text{ mVpp}; m = 50\% \end{matrix}$$

ID filter gain	$V_{KT \text{ Filter}}$	3.4		6.8	V	$f_5 = \text{Pilot signal dual};$ I ² C-talk: dual	2
ID filter gain	$V_{KT \text{ Filter}}$	3.4		6.8	V	$f_5 = \text{Pilot signal stereo};$ I ² C-talk: stereo	2

$$V_{5 \text{ test}} = V_{25} (V_5 = 0) \pm \Delta V_{25}; V_{26 \text{ test}} = V_{26} (V_5 = 0) \pm \Delta V_{26}$$

Characteristics (cont'd)

Parameter	Symbol	Limit Values			Unit	Test Condition	Test Circuit
		min.	typ.	max.			
Detection threshold	ΔV_{25}	900			mV	I ² C-talk: stereo or dual	3
Detection threshold	$-\Delta V_{25}$	900			mV	I ² C-talk: stereo or dual	3
Detection threshold	ΔV_{26}	900			mV	I ² C-talk: stereo or dual	3
Detection threshold	$-\Delta V_{26}$	900			mV	I ² C-talk: stereo or dual	3
Mono threshold	ΔV_{25}	0		100	mV	I ² C-talk: mono	3
Mono threshold	$-\Delta V_{25}$	0		100	mV	I ² C-talk: mono	3
Mono threshold	ΔV_{26}	0		100	mV	I ² C-talk: mono	3
Mono threshold	$-\Delta V_{26}$	0		100	mV	I ² C-talk: mono	3
Response of detection	f_{detect}	1/4		1/2	t _{MPX}	I ² C-talk: stereo or dual; $\pm \Delta V_{25} = 1V$	3
Response of detection	f_{detect}	1/4		1/2	t _{MPX}	I ² C-talk: stereo or dual; $\pm \Delta V_{26} = 1V$	3

Characteristics (cont'd)

Parameter	Symbol	Limit Values			Unit	Test Condition	Test Circuit
		min.	typ.	max.			
Switching threshold f_{REF} -input	$V_{H\ in\ L}$	0		1.5	V		2
Switching threshold f_{REF} -input	$V_{H\ in\ L}$	3.5		V_{21}	V		2
Amplitude crystal oscillator	V_{24}		2		V_{pp}	$f_0 = 4.00000\ MHz$ Serial resonance	2
Ext. 1- or 4 MHz-clock signal	V_{24}		0.3		V_{pp}		3
Multiplexer clock	f_{MPX4}		1.08		s	00,C0, $MPX = 1$	
Multiplexer clock	f_{MPX4}		2.17		s	00,00, $MPX = 2$	
Multiplexer clock	f_{MPX4}		4.34		s	00,40, $MPX = 4$	
Multiplexer clock	f_{MPX4}		8.68		s	00,80, $MPX = 8$	

Design-Related Data

Filter output resistance	$R_{25,26}$	110			$k\Omega$		
f_{REF} input resistance	R_{24}	800			Ω		
Input impedance crystal oscillator	Z_{24}		-120		Ω		

Characteristics (cont'd)

Parameter	Symbol	Limit Values			Unit	Test Condition
		min.	typ.	max.		
I²C Bus (SCL, SDA)						
SCL, SDA edges						
Rise time	t_R			1	μ s	
Fall time	t_F			300	ns	
Shift register clock pulse SCL						
Frequency	f_{SCL}	0		100	kHz	
H-pulse width	t_{HIGH}	4			μ s	
L-pulse width	t_{LOW}	4			μ s	
Start						
Set-up time	t_{SUSTA}	4			μ s	
Hold time	t_{HDSTA}	4			μ s	
Stop						
Set-up time	t_{SUDAT}	1			μ s	
Bus free time	t_{HDDAT}	1			μ s	
Data transfer						
Set-up time	t_{SUDAT}	1			μ s	
Hold time	t_{HDDAT}	1			μ s	
Input SCL, SDA						
Input voltage	V_{QH}	2.4		5.5	V	
	V_{QL}			1	V	
Input current	V_{QH}			50	μ A	
	V_{QL}			100	μ A	
Output SDA (Open collector)						
Output voltage	V_{QH}	5.4			V	$R_L = 2.5 \text{ k}\Omega$
	V_{QL}			0.4	V	$I_{QL} = 3 \text{ mA}$

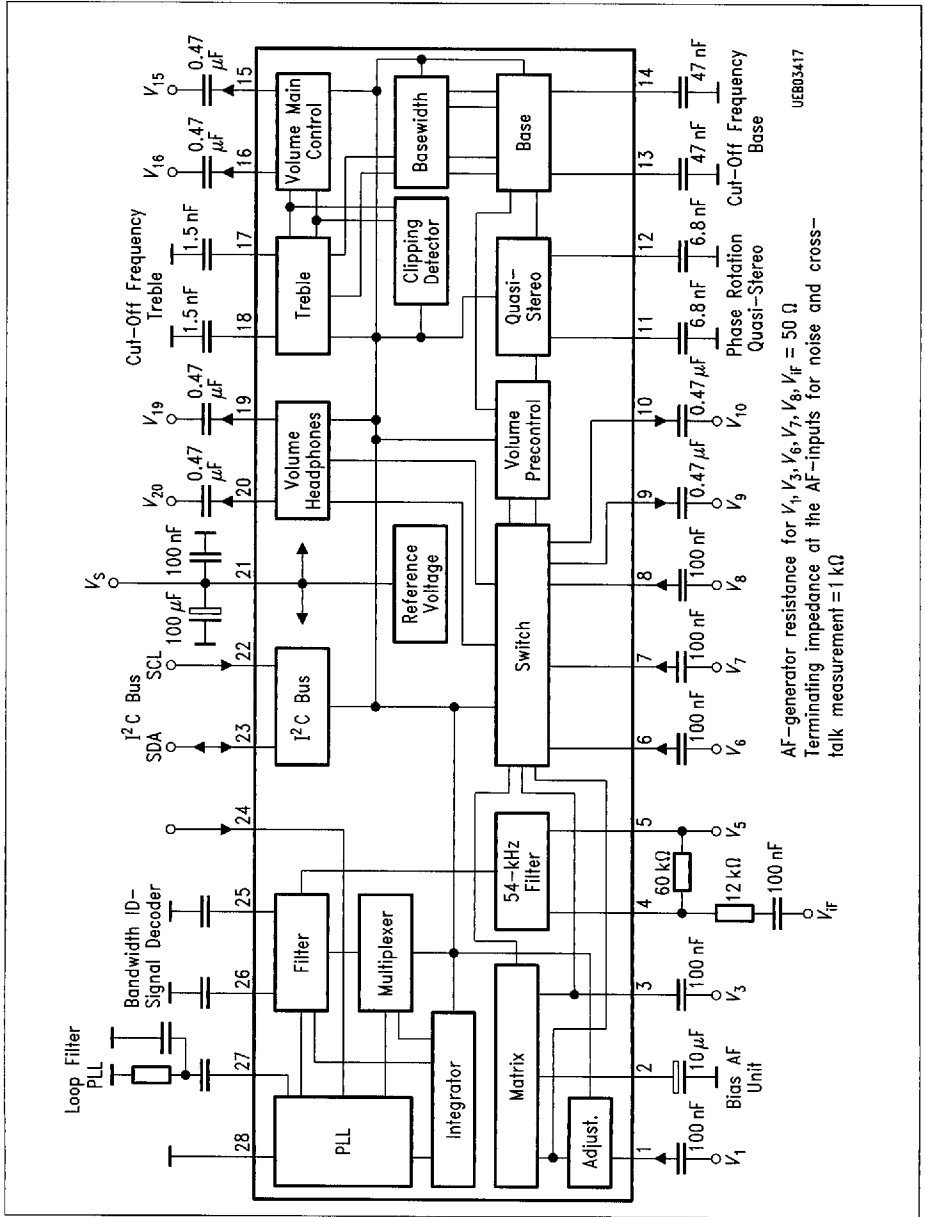

Test Circuit 1

■ 8235605 0058357 905 ■

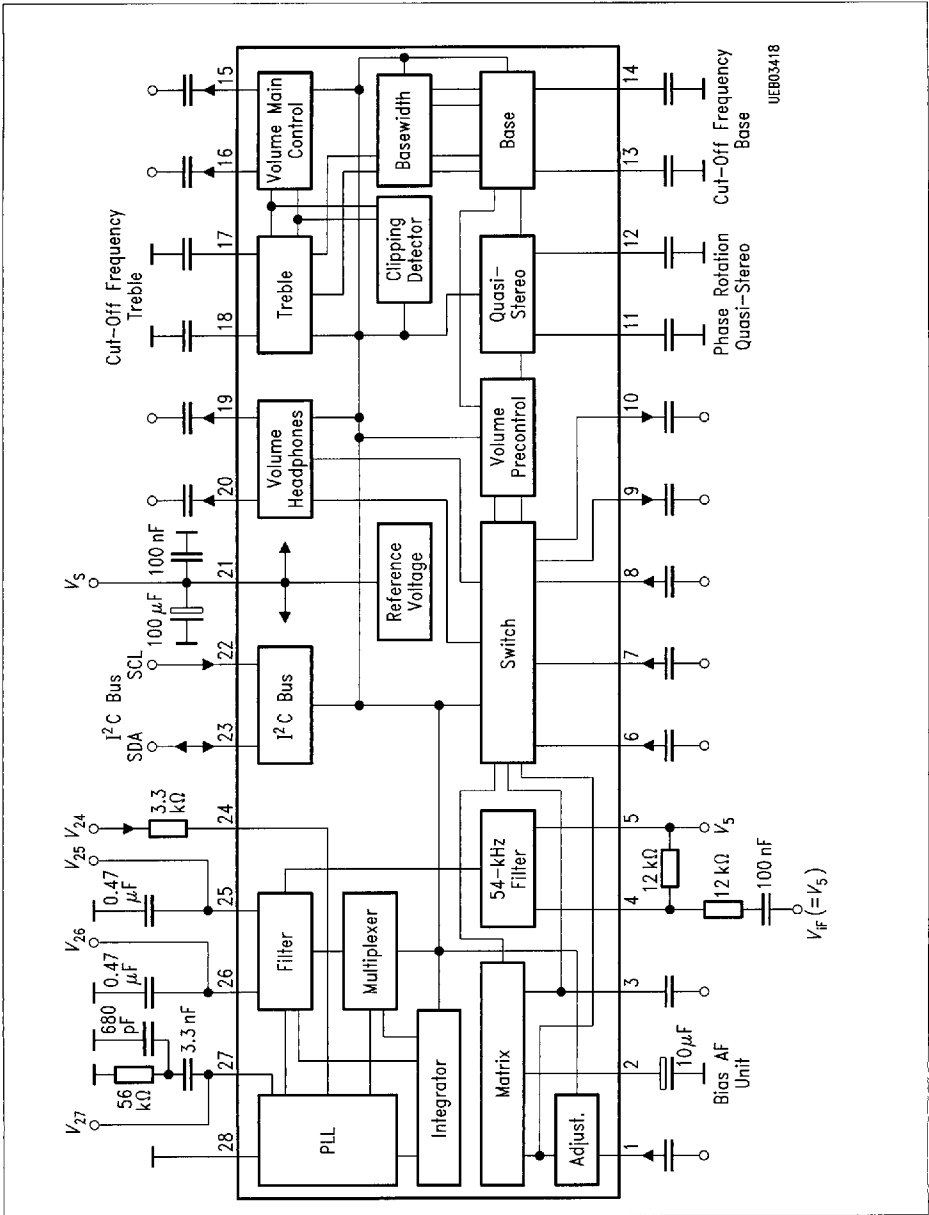

UF603418

Test Circuit 2

8235605 0058358 841

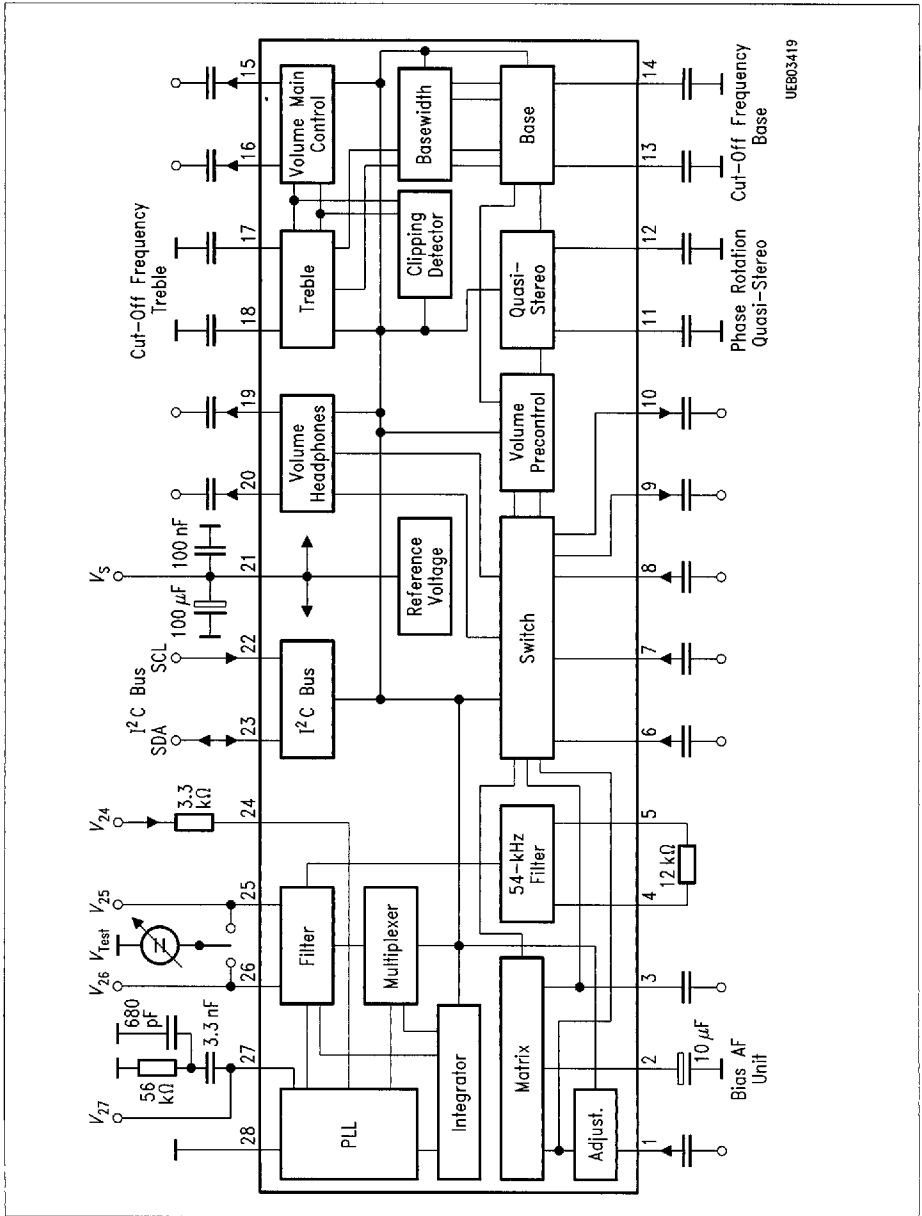

Test Circuit 3

8235605 0058359 788

Plastic Package, P-DIP-28-3
(Dual-in-Line)

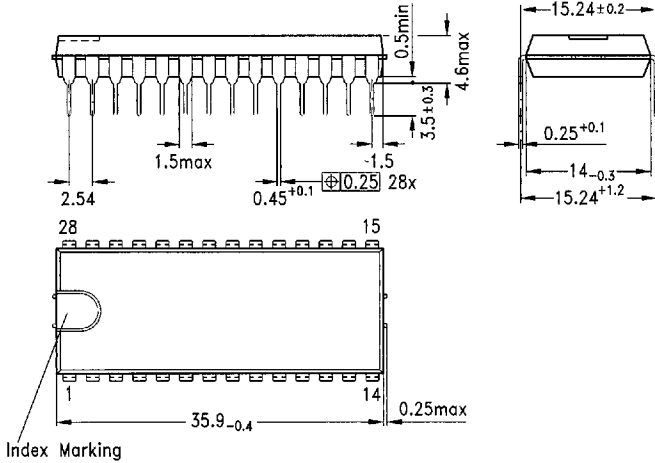

Plastic Package, P-DIP-40-2
(Dual-in-Line)

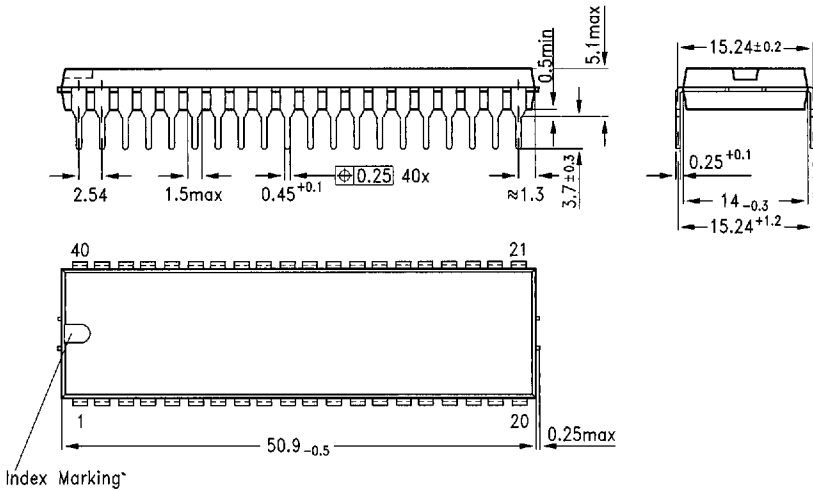

Dimensions in mm

Plastic Package P-DSO-28-1 (SMD)
 (Plastic Dual Small Outline)

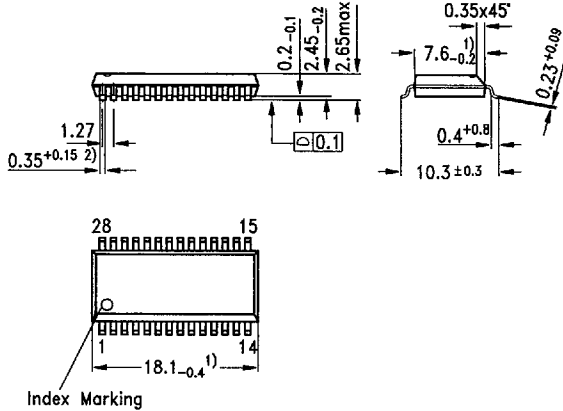

- 1) Does not include plastic or metal protrusions of 0.15 max per side
- 2) Does not include dambar protrusion of 0.05 max per side

Sorts of Packing

Package outlines for tubes, trays ect. are contained in our Data Book "Package Information"

SMD - Surface Mounted Devices

■ 8235605 0058398 428 ■

Semiconductor Group

Dimensions in mm
 B111-H6621-
 G1-X-7600