



TDA7297

LINEAR INTEGRATED CIRCUIT

10+10W DUAL BRIDGE AMPLIFIER

■ DESCRIPTION

The UTC **TDA7297** is a dual bridge amplifier, it uses UTC advanced technology to provide customers with wide supply voltage, stand-by function, mute function, thermal overload protection and short circuit protection, etc.

The UTC **TDA7297** is suitable for TV and Portable Radio applications, etc.

■ FEATURES

- * St-by and mute functions
- * OTP and short circuit protections
- * Work with a minimum external components
- * Wide supply voltage range (6.5V~18V)

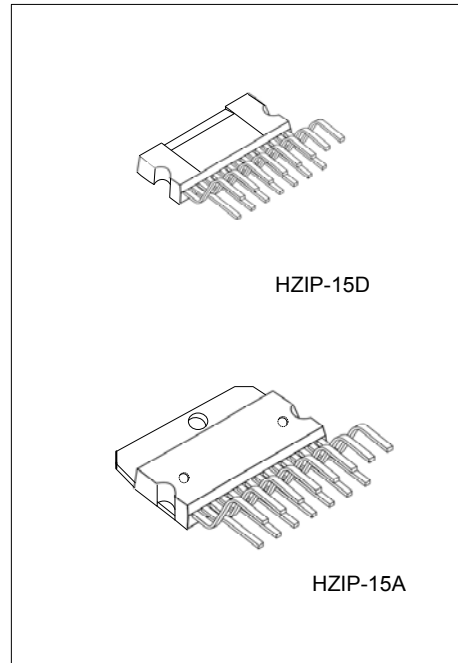

■ ORDERING INFORMATION

Ordering Number		Package	Packing
Lead Free	Halogen Free		
TDA7297L-J15-A-T	TDA7297G-J15-A-T	HZIP-15A	Tube
TDA7297L-J15-D-T	TDA7297G-J15-D-T	HZIP-15D	Tube

Note: xx: Output Voltage, refer to Marking Information.

<p>TDA7297L-J15-D-T</p> <ul style="list-style-type: none"> (1) Packing Type (2) Package Type (3) Green Package 	<ul style="list-style-type: none"> (1) T: Tube (2) J15-A: HZIP-15A, J15-D: HZIP-15D (3) L: Lead Free, G: Halogen Free and Lead Free
---	--

■ MARKIN

HZIP-15A	HZIP-15D

■ PIN CONFIGURATION

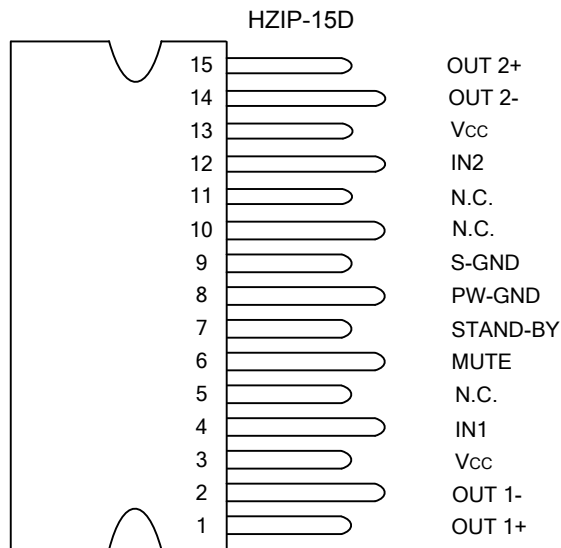
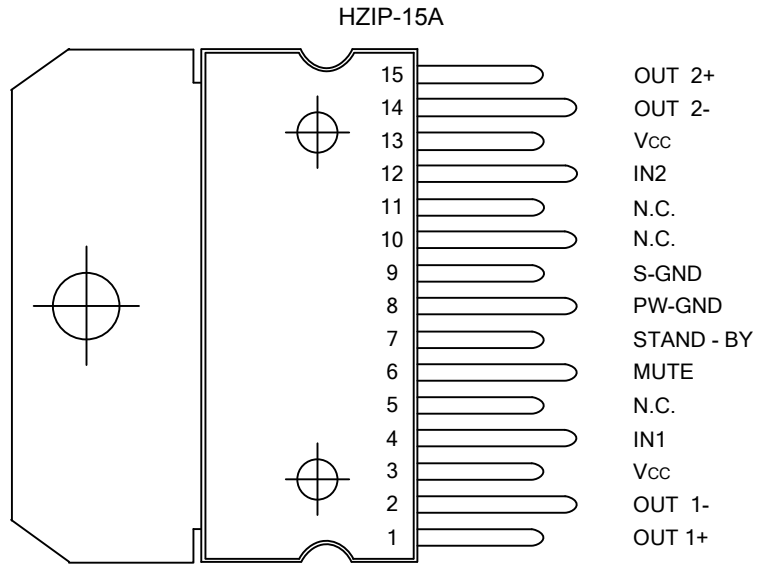

■ PIN DESCRIPTION

PIN NO.	PIN NAME	DESCRIPTION
1	OUT1+	Non-Inverting Output of Channel 1
2	OUT1-	Inverting Output of Channel 1
3	V _{CC}	Supply Voltage
4	IN1	Input of Channel 1
5	N.C.	Not Connected
6	MUTE	Mute Function Terminal
7	STAND-BY	Stand-by Function Terminal
8	PW-GND	Power Ground
9	S-GND	Signal Ground
10	N.C.	Not Connected
11	N.C.	Not Connected
12	IN2	Input of Channel 2
13	V _{CC}	Supply Voltage
14	OUT2-	Inverting Output of Channel 2
15	OUT2+	Non-Inverting Output of Channel 2

■ BLOCK DIAGRAM

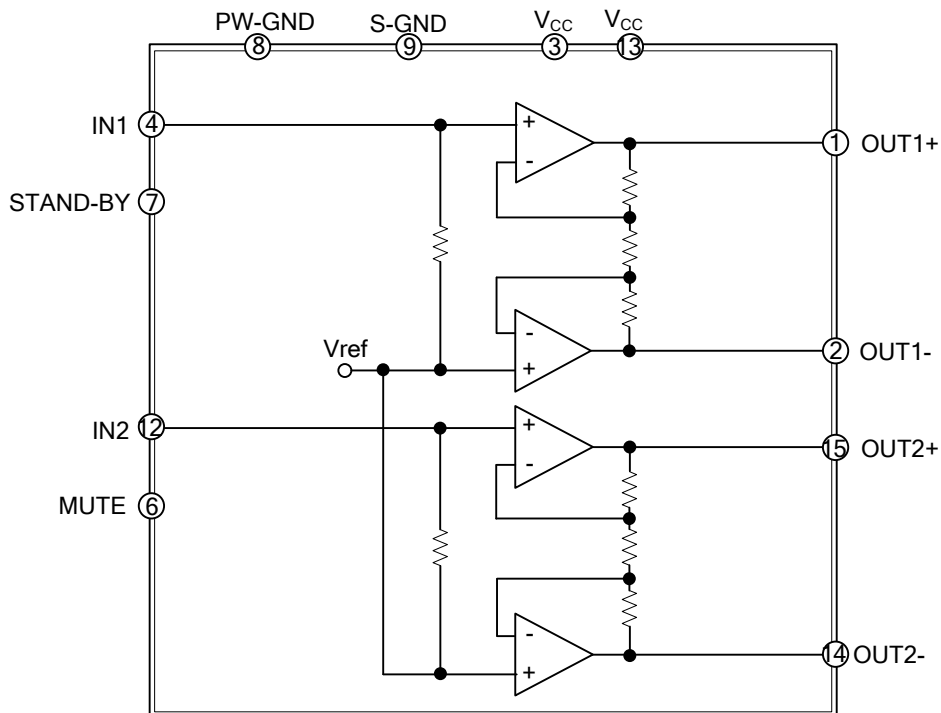

■ ABSOLUTE MAXIMUM RATING

PARAMETER	SYMBOL	RATINGS	UNIT
Supply Voltage	V_S	20	V
Output Peak Current (Internally Limited)	I_O	2	A
Total Power Dissipation ($T_C=70^\circ\text{C}$)	P_{TOT}	30	W
Operating Temperature	T_{OPR}	0~70	$^\circ\text{C}$
Junction Temperature	T_J	150	$^\circ\text{C}$
Storage Temperature	T_{STG}	-40~+150	$^\circ\text{C}$

Note: Absolute maximum ratings are those values beyond which the device could be permanently damaged. Absolute maximum ratings are stress ratings only and functional device operation is not implied.

■ THERMAL DATA

DESCRIPTION	SYMBOL	RATINGS	UNIT
Junction to Ambient	HZIP-15A	38	$^\circ\text{C/W}$
	HZIP-15D	48	$^\circ\text{C/W}$
Junction to Case	HZIP-15A	1.5	$^\circ\text{C/W}$
	HZIP-15D	1.8	$^\circ\text{C/W}$

■ ELECTRICAL CHARACTERISTICS

($V_{CC}=13\text{V}$, $R_L=8\Omega$, $f=1\text{kHz}$, $T_A=25^\circ\text{C}$, unless otherwise specified)

PARAMETER	SYMBOL	TEST CONDITIONS	MIN	TYP	MAX	UNIT
Supply Range	V_{CC}		6.5		18	V
Total Quiescent Current	I_q	$R_L=\infty$		50	65	mA
Output Offset Voltage	V_{OS}				120	mV
Output Power	P_O	THD=10%	8.3	10		W
Total Harmonic Distortion	THD	$P_O=1\text{W}$		0.1	0.3	%
		$P_O=0.1\text{W}\sim 2\text{W}$, $f=100\text{Hz}\sim 15\text{kHz}$			1	%
Supply Voltage Rejection	SVR	$f=100\text{Hz}$ $V_R=0.5\text{V}$	40	56		dB
Crosstalk	CT		46	60		dB
Mute Attenuation	A_{MUTE}		60	80		dB
Thermal Threshold	T_W			150		$^\circ\text{C}$
Closed Loop Voltage Gain	G_V		31	32	33	dB
Voltage Gain Matching	ΔG_V				0.5	dB
Input Resistance	R_i		25	30		k Ω
Mute Threshold	$V_{T_{MUTE}}$	$V_O=-30\text{dB}$	2.3	2.9	4.1	V
ST-BY Threshold	$V_{T_{ST-BY}}$		0.8	1.3	1.8	V
ST-BY Current $V_6=\text{GND}$	I_{ST-BY}				100	μA
Total Output Noise Voltage	e_N	A curve		150		μV
		$f=20\text{Hz}\sim 20\text{kHz}$		220	500	μV

■ APPLICATION SUGGESTION

STAND-BY AND MUTE FUNCTIONS

a. Microprocessor Application

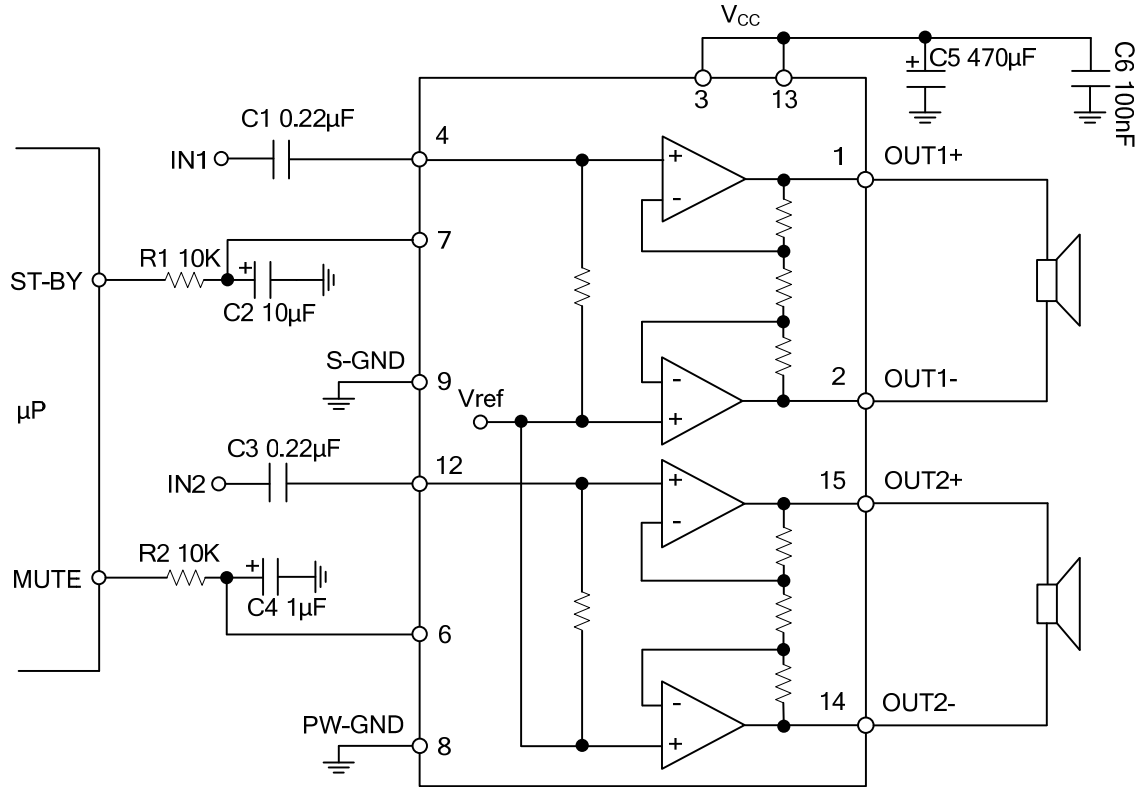

Fig. 1 Microprocessor Application

■ APPLICATION SUGGESTION(Cost.)

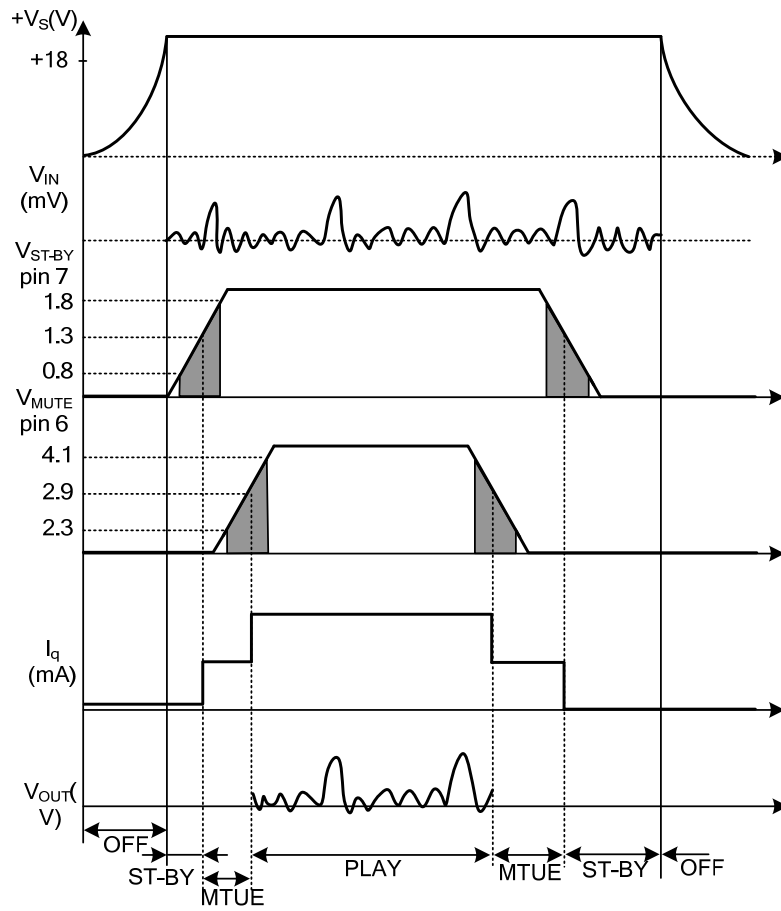

Fig. 2 Microprocessor Driving Signals

■ APPLICATION SUGGESTION(Cost.)

b. Low Cost Application

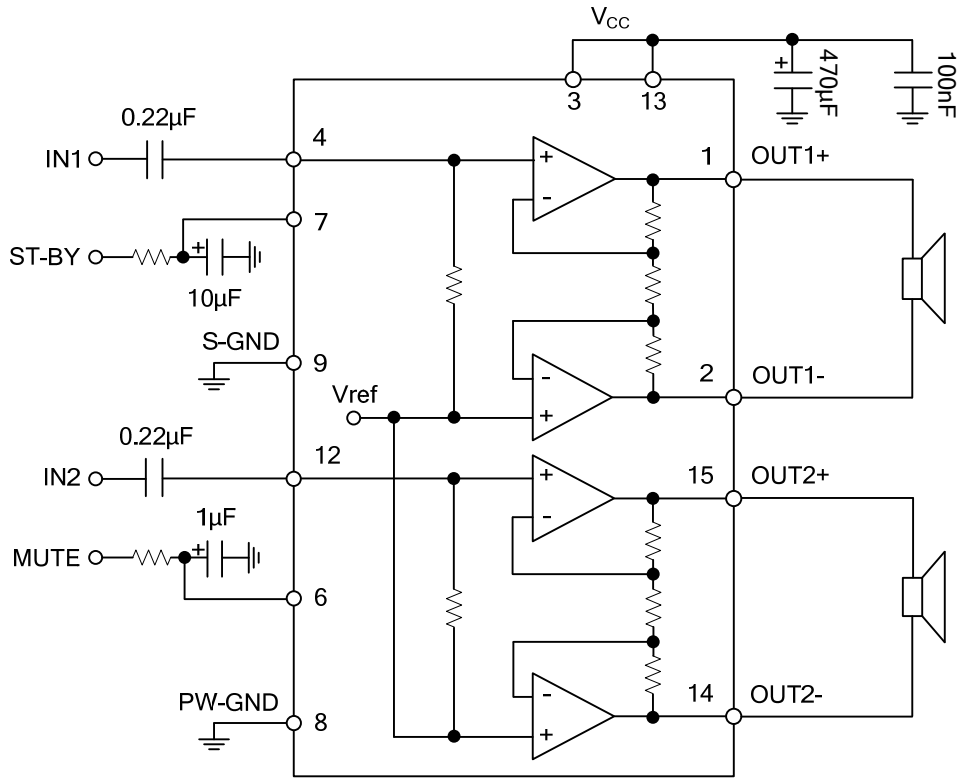
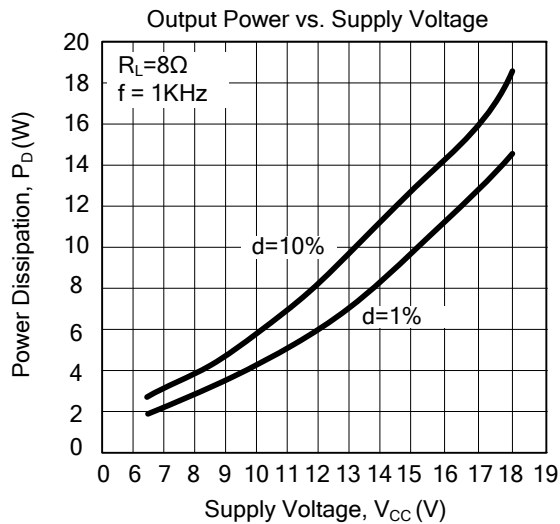
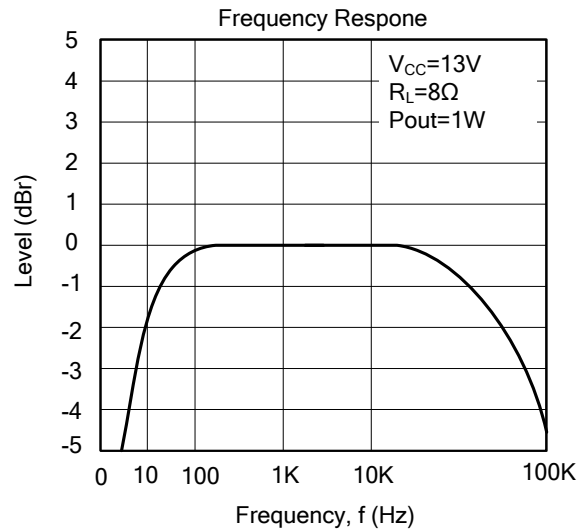
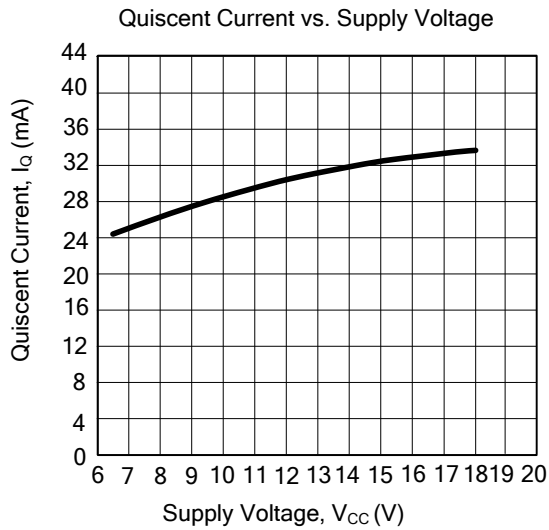

Fig. 3 Stand-alone Low-cost Application

■ TYPICAL CHARACTERISTICS



UTC assumes no responsibility for equipment failures that result from using products at values that exceed, even momentarily, rated values (such as maximum ratings, operating condition ranges, or other parameters) listed in products specifications of any and all UTC products described or contained herein. UTC products are not designed for use in life support appliances, devices or systems where malfunction of these products can be reasonably expected to result in personal injury. Reproduction in whole or in part is prohibited without the prior written consent of the copyright owner. The information presented in this document does not form part of any quotation or contract, is believed to be accurate and reliable and may be changed without notice.