

**CONTROL HEAD PLAYBACK
& RECORD AMPLIFIER AND SIGNALS INTERFACE**

- CONTROL HEAD PLAYBACK AMPLIFIER WITH AGC
- CONTROL HEAD RECORD AMPLIFIER WITH SINK/SOURCE OUTPUT STAGE
- CONTROL PLAY-BACK SIGNAL INVERTER
- 4 COMPARATORS WITH INTERNAL FIXED THRESHOLD (2.5V)
- COMPARATORS WITH GROUND/ V_s COMPATIBLE INPUTS AND OPEN COLLECTOR OUTPUTS

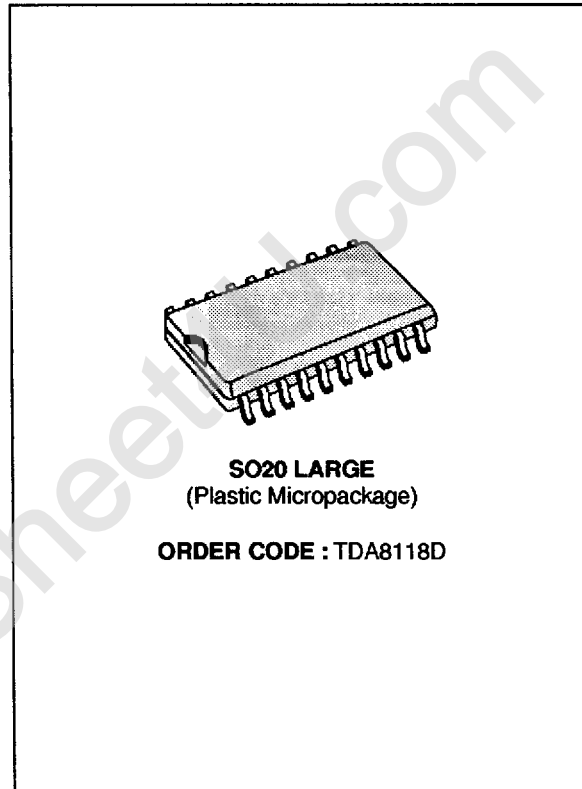

DESCRIPTION

The TDA8118 is a bipolar integrated circuit for VCR application. It is intended to process the CTL-signal in record and playback mode. An internal AGC provides a wide range of input signal level. 5 further internal hysteresis comparators are intended to convert signals from optical and hall sensors to TTL-level.

PIN CONNECTIONS

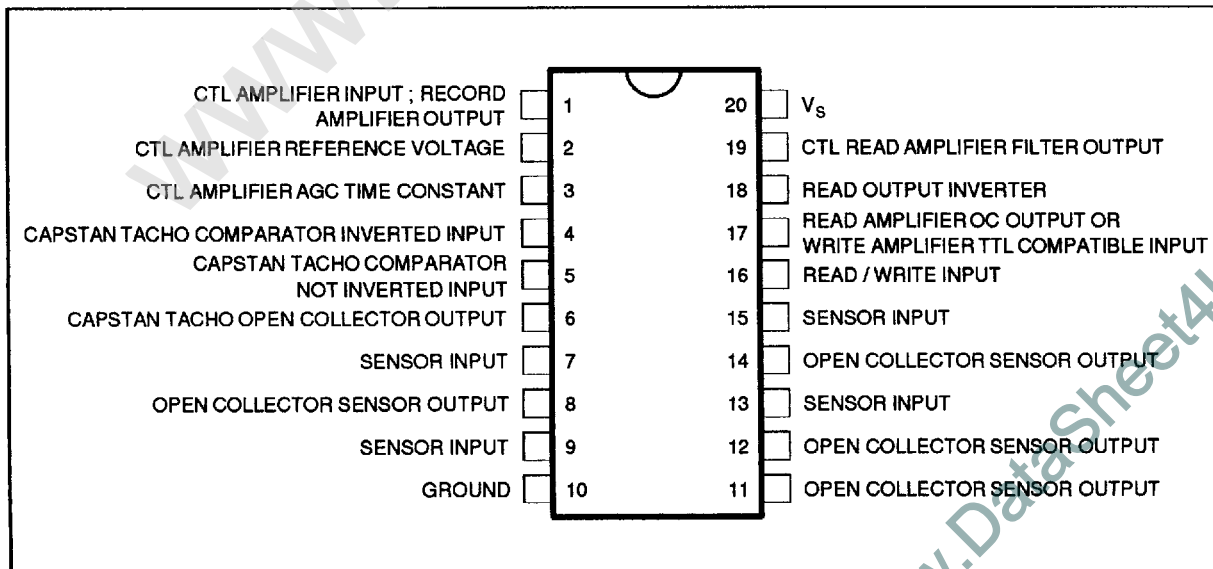

8118-01.EPS

BLOCK DIAGRAM

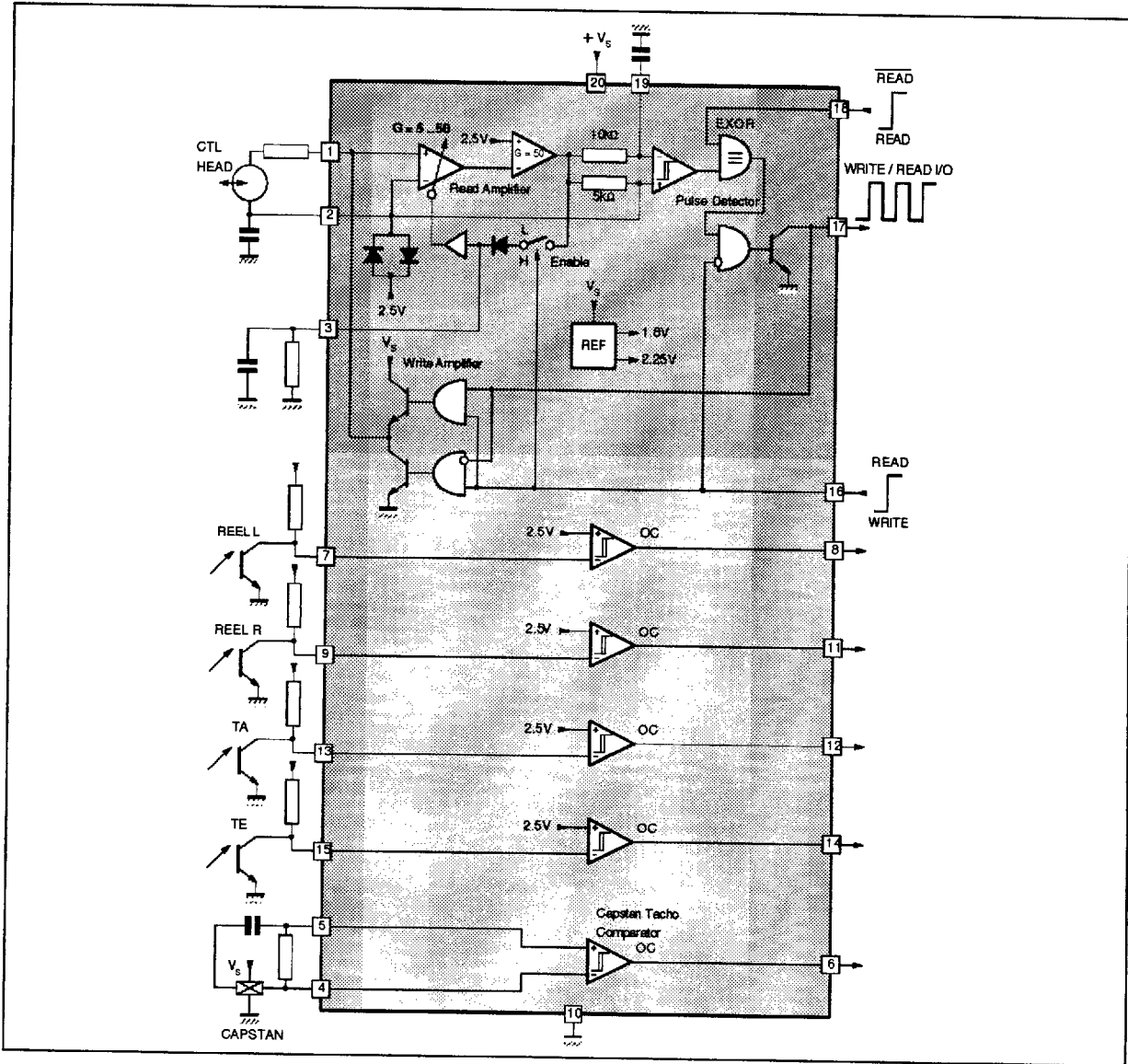

8118-02.ERS

ABSOLUTE MAXIMUM RATINGS

Symbol	Parameter	Value	Unit
V_s	DC Supply Voltage	14	V
V_i	DC Input Voltage	- 0.3 to V_s	V
V_o	DC Output Voltage	V_s	V
I_o	Open Collector Output Current	5	mA
T_{stg}	Storage Temperature	-55 to 125	°C
T_j	Operating Junction Temperature	0 to 85	°C

Note : The circuit is ESD protected according to MIL-STD-883C

8118-01.TBL

THERMAL DATA

Symbol	Parameter	Value	Unit
$R_{th(j-a)}$	Junction-ambient Thermal Resistance	70	°C/W

8118-02.TBL

ELECTRICAL CHARACTERISTICS

$V_S = 5V \pm 5\%$, $T_{amb} = 25^\circ C$ (unless otherwise specified)

Symbol	Parameter	Test Conditions	Min.	Typ.	Max.	Unit
V_S	Operating Supply Voltage (Pin 20)		4.5		6	V
I_S	Supply Current (Pin 20)	Pins 6, 8, 11, 12, 14, 16, 17 open			5	mA

CTL READ AMPLIFIER

V_{REF}	CTL Reference Voltage (Pin 2)		2.1	2.25	2.4	V
R_{IN}	Input Resistance (Pin 1)		100			k Ω
G_V	Voltage Gain (Pins 1/19)	AGC not active, Pin 3 = GND, $f = 1\text{kHz}$	66			dB
ΔG_V	Voltage Gain range of AGC (Pins 1/19)	$f = 1\text{kHz}$, $R_S = 220\text{k}\Omega$, $C_3 = 33\mu\text{F}$		18		dB
R_F	Filter Output Impedance (Pin 19)		7	10	13	k Ω
V_{IN}	Minimum Peak Input Voltage (Pin 1)		0.5			mV

CTL PULSE DETECTOR

I_{H+}	Positive Schmitt Trigger Threshold (Pins 17/19)	See timing diagram		$V_Z + 0.5$		V
I_{H-}	Negative Schmitt Trigger Threshold (Pins 17/19)	See timing diagram		$V_Z - 0.5$		V
V_{SAT}	Output Saturation Voltage (Pin 17)	$V_{17} = \text{Low}$, $I_{17} = 1.8\text{mA}$			0.4	V
I_C	Output Leakage Current (Pin 17)	$V_{17} = V_S$			10	μA
V_{REL}	Read Inverter Input Low Voltage (Pin 18)		-0.3		1.5	V
V_{REH}	Read Inverter Input High Voltage (Pin 18)		2.3		V_S	V

CTL WRITE AMPLIFIER

V_{RWL}	Read/Write Enable Input Low Voltage (Pin 16)		-0.3		1.5	V
V_{RWH}	Read/Write Enable Input High Voltage (Pin 16)		2.3		V_S	V
V_{WRL}	Write Input Low Voltage (Pin 17)	Pin 16 = Low	-0.3		1.5	V
V_{WRH}	Write Input High Voltage (Pin 17)	Pin 16 = Low	2.3		V_S	V
V_{SATL}	Output Saturation Voltage Low State (Pin 1)	$I_{SINK} = 5\text{mA}$, Pin 16 = Low, Pin 17 = Low			0.4	V
V_{SATH}	Output Saturation Voltage High State (Pin 1)	Pin 16 = Low, Pin 17 = High $I_{SOURCE} = 5\text{mA}$ $I_{SOURCE} = 2\text{mA}$			1.5 1.3	V V

SENSOR INTERFACE

I_{IN}	Input Bias Current (Pins 7/9, 13/15)	$V_{IN} = 1V$	-3		1	μA
I_{TH}	Input Threshold Voltage (Pins 7/9, 13/15)		2.1	2.25	2.4	V
I_{HYS}	Input Hysteresis (Pins 7/9, 13/15)		150	200	250	mV
V_{SAT}	Output Saturation Voltage (Pins 8/11/12/14)	$I_{SINK} = 1.8\text{mA}$			0.4	V
I_L	Output Leakage Current (Pins 8/11/12/14)	$V_{OUT} = V_S$			10	μA

CAPSTAN TACHO COMPARATOR

I_{IN}	Input Bias Current (Pins 4/5)	$V_{IN} = \text{Low}$	-3		1	μA
V_{OFF}	Input Offset Voltage (Pins 4/5)				5	mV
I_{HYS}	Input Hysteresis (Pins 4/5)			5	10	mV
V_{SAT}	Output Saturation Voltage (Pin 6)	$I_{SINK} = 1.8\text{mA}$			0.4	V
I_{LEAK}	Output Leakage Current (Pin 6)	$V_{OUT} = V_S$			10	μA

8118-03.TBL

TIMING DIAGRAM

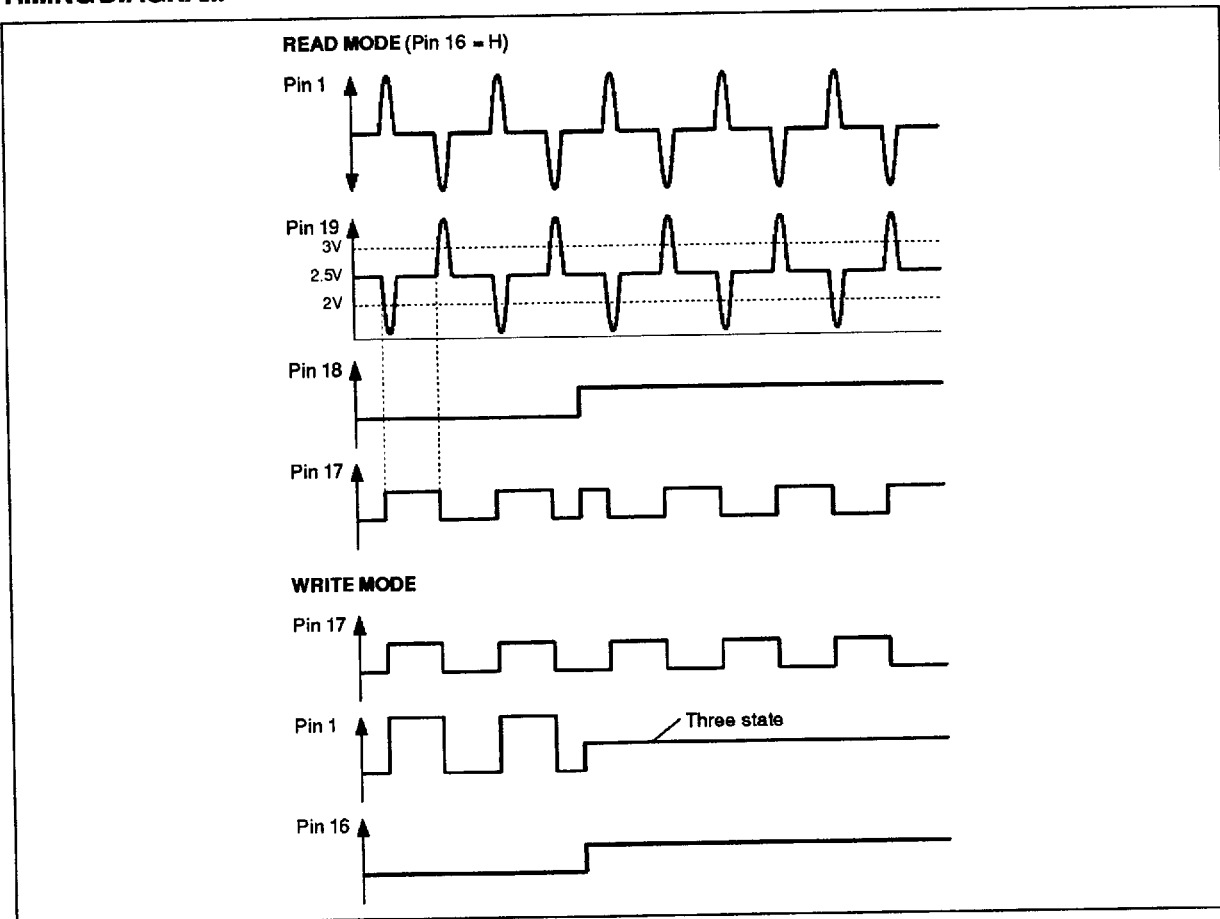

8118-03.EPS

PACKAGE MECHANICAL DATA
20 PINS - PLASTIC MICROPACKAGE

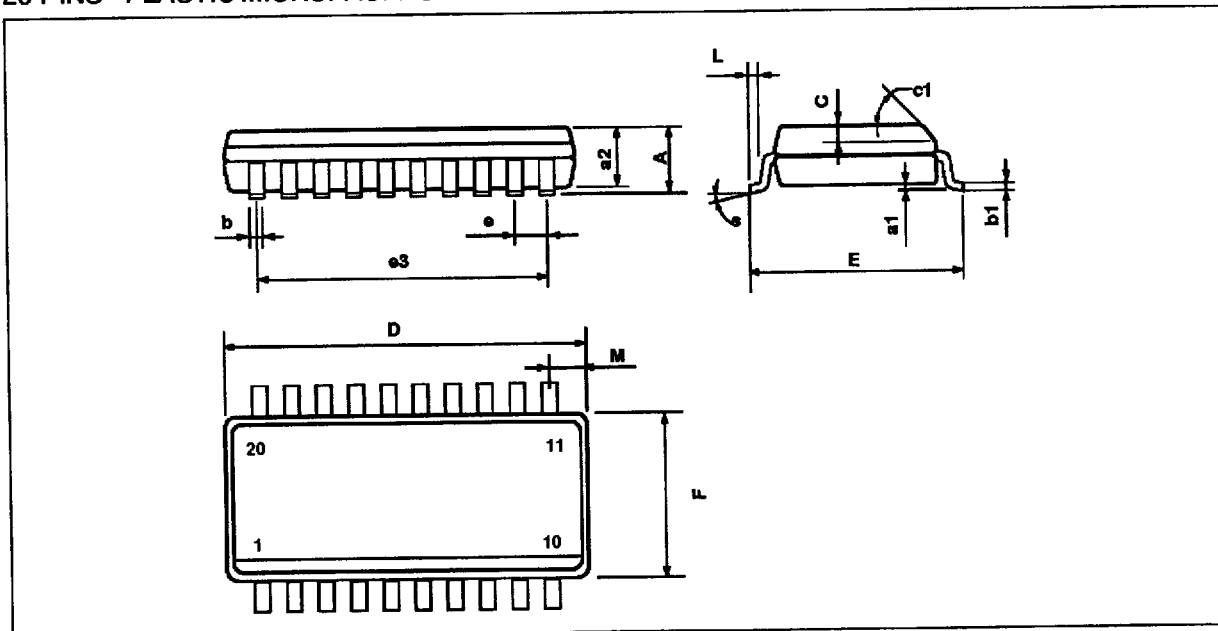

Dimensions	Millimeters			Inches		
	Min.	Typ.	Max.	Min.	Typ.	Max.
A			2.65			0.104
a1	0.1		0.2	0.004		0.008
a2			2.45			0.096
b	0.35		0.49	0.014		0.019
b1	0.23		0.32	0.009		0.013
C		0.5			0.020	
c1	45° (typ.)					
D	12.6		13.0	0.496		0.510
E	10		10.65	0.394		0.419
e		1.27			0.050	
e3		11.43			0.450	
F	7.4		7.6	0.291		0.300
L	0.5		1.27	0.020		0.050
M			0.75			0.030
S	8° (max.)					

Information furnished is believed to be accurate and reliable. However, SGS-THOMSON Microelectronics assumes no responsibility for the consequences of use of such information nor for any infringement of patents or other rights of third parties which may result from its use. No licence is granted by implication or otherwise under any patent or patent rights of SGS-THOMSON Microelectronics. Specifications mentioned in this publication are subject to change without notice. This publication supersedes and replaces all information previously supplied. SGS-THOMSON Microelectronics products are not authorized for use as critical components in life support devices or systems without express written approval of SGS-THOMSON Microelectronics.

© 1994 SGS-THOMSON Microelectronics - All Rights Reserved

Purchase of μ C Components of SGS-THOMSON Microelectronics, conveys a license under the Philips μ C Patent. Rights to use these components in a μ C system, is granted provided that the system conforms to the μ C Standard Specifications as defined by Philips.

SGS-THOMSON Microelectronics GROUP OF COMPANIES

Australia - Brazil - China - France - Germany - Hong Kong - Italy - Japan - Korea - Malaysia - Malta - Morocco
 The Netherlands - Singapore - Spain - Sweden - Switzerland - Taiwan - Thailand - United Kingdom - U.S.A.