

2N AND 2P-CHANNEL Enhancement Mode MOSFET

TDM3411

**DESCRIPTION**

The TDM3411 uses advanced trench technology to provide excellent RDS(ON) and low gate charge. This device is suitable for use as a load switch or in PWM applications.

**GENERAL FEATURES**

- N CHANNEL  
RDS(ON) < 35mΩ @ VGS=4.5V  
RDS(ON) < 31mΩ @ VGS=10V
- P CHANNEL  
RDS(ON) < 43mΩ @ VGS=-4.5V  
RDS(ON) < 33mΩ @ VGS=-10V
- High Power and current handling capability
- Lead free product is available
- SOP-8 Package

**Application**

- PWM applications
- Load switch
- Power management
- Hard Switched and High Frequency Circuits

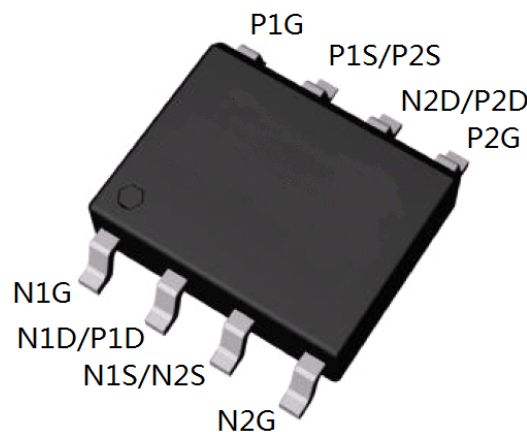
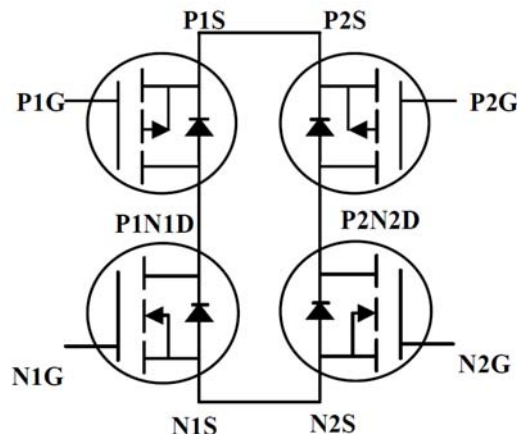

ABSOLUTE MAXIMUM RATINGS(TA=25°C unless otherwise noted)

Parameter	Symbol	Limit		Unit
		N-channel	P-channel	
Drain-Source Voltage	V <sub>DS</sub>	30	-30	V
Gate-Source Voltage	V <sub>GS</sub>	+20	+20	V
Drain Current @ Continuous	I <sub>D</sub> (TA=25°C)	6	-4.5	A
	I <sub>D</sub> (TA=70°C)	4.8	-3.6	A
Drain Current @ Current-Pulsed (Note 1)	I <sub>DM</sub>	22.5	22.5	A
Maximum Power Dissipation (TA=25°C)	P <sub>D</sub>	2.0		W
Maximum Operating Junction Temperature	T <sub>J</sub>	150		°C
Storage Temperature Range	T <sub>STG</sub>	-55 To 150		°C

THERMAL CHARACTERISTICS

Thermal Resistance,Junction-to-Ambient (Note 1)	R <sub>θJA</sub>	90	°C/W
---	------------------	----	------

**N-CH ELECTRICAL CHARACTERISTICS** ( $T_A=25^\circ\text{C}$  unless otherwise noted)

Parameter	Symbol	Condition	Min	Typ	Max	Unit
<b>OFF CHARACTERISTICS</b>						
Drain-Source Breakdown Voltage	$BV_{DSS}$	$V_{GS}=0V, I_D=250\mu A$	30			V
Zero Gate Voltage Drain Current	$I_{DSS}$	$V_{DS}=24V, V_{GS}=0V$			1	$\mu A$
Gate-Body Leakage Current	$I_{GSS}$	$V_{GS}=\pm 20V, V_{DS}=0V$			$\pm 100$	nA
<b>ON CHARACTERISTICS</b> (Note 2)						
Gate Threshold Voltage	$V_{GS(th)}$	$V_{DS}=V_{GS}, I_D=250\mu A$	1.3	1.8	2.5	V
Drain-Source On-State Resistance	$R_{DS(on)}$	$V_{GS}=4.5V, I_D=5A$		31	35	m $\Omega$
		$V_{GS}=10V, I_D=8A$		25	31	m $\Omega$
<b>DYNAMIC CHARACTERISTICS</b> (Note3)						
Input Capacitance	$C_{iss}$	$V_{DS}=15V, V_{GS}=0V, F=1.0MHz$	300	410	550	PF
Output Capacitance	$C_{oss}$		40	70	100	PF
Reverse Transfer Capacitance	$C_{rss}$		30	40	60	PF
<b>SWITCHING CHARACTERISTICS</b> (Note 3)						
Total Gate Charge	$Q_g$	$V_{DS}=15V, I_D=8A, V_{GS}=4.5V$	-	3.8	5.5	nC
Gate-Source Charge	$Q_{gs}$		-	1.3	-	nC
Gate-Drain Charge	$Q_{gd}$		-	1.6	-	nC
<b>DRAIN-SOURCE DIODE CHARACTERISTICS</b>						
Diode Forward Voltage (Note 2)	$V_{SD}$	$V_{GS}=0V, I_S=5A$		0.8	1.3	V

**NOTES:**

1. Pulse width limited by max. junction temperature.
2. Pulse Test: Pulse Width  $\leq 300\mu s$ , Duty Cycle  $\leq 2\%$ .
3. Guaranteed by design, not subject to production testing

**P-CH ELECTRICAL CHARACTERISTICS ( $T_A=25^{\circ}\text{C}$  unless otherwise noted)**

Parameter	Symbol	Condition	Min	Typ	Max	Unit
<b>OFF CHARACTERISTICS</b>						
Drain-Source Breakdown Voltage	$BV_{DSS}$	$V_{GS}=0V, I_D=-250\mu A$	-30			V
Zero Gate Voltage Drain Current	$I_{DSS}$	$V_{DS}=-24V, V_{GS}=0V$			-1	$\mu A$
Gate-Body Leakage Current	$I_{GSS}$	$V_{GS}=\pm 20V, V_{DS}=0V$			$\pm 100$	nA
<b>ON CHARACTERISTICS (Note 2)</b>						
Gate Threshold Voltage	$V_{GS(th)}$	$V_{DS}=V_{GS}, I_D=250\mu A$	-1.3	-1.8	-2.3	V
Drain-Source On-State Resistance	$R_{DS(on)}$	$V_{GS}=-4.5V, I_D=-4A$		39	43	$m\Omega$
		$V_{GS}=-10V, I_D=9.3A$		29	33	$m\Omega$
<b>DYNAMIC CHARACTERISTICS (Note3)</b>						
Input Capacitance	$C_{iss}$	$V_{DS}=-15V, V_{GS}=0V, F=1.0MHz$	-	840	-	PF
Output Capacitance	$C_{oss}$		-	150	-	PF
Reverse Transfer Capacitance	$C_{rss}$		-	110	-	PF
<b>SWITCHING CHARACTERISTICS (Note 3)</b>						
Total Gate Charge	$Q_g$	$V_{DS}=-15V, I_D=-9.3A, V_{GS}=-10V$	-	18	-	nC
Gate-Source Charge	$Q_{gs}$		-	3	-	nC
Gate-Drain Charge	$Q_{gd}$		-	4	-	nC
<b>DRAIN-SOURCE DIODE CHARACTERISTICS</b>						
Diode Forward Voltage (Note 2)	$V_{SD}$	$V_{GS}=0V, I_S=-2A$		-0.8	-1.1	V

**NOTES:**

1. Pulse width limited by max. junction temperature.
2. Pulse Test: Pulse Width  $\leq 300\mu s$ , Duty Cycle  $\leq 2\%$ .
3. Guaranteed by design, not subject to production testing

Package Information

SOP-8 Package

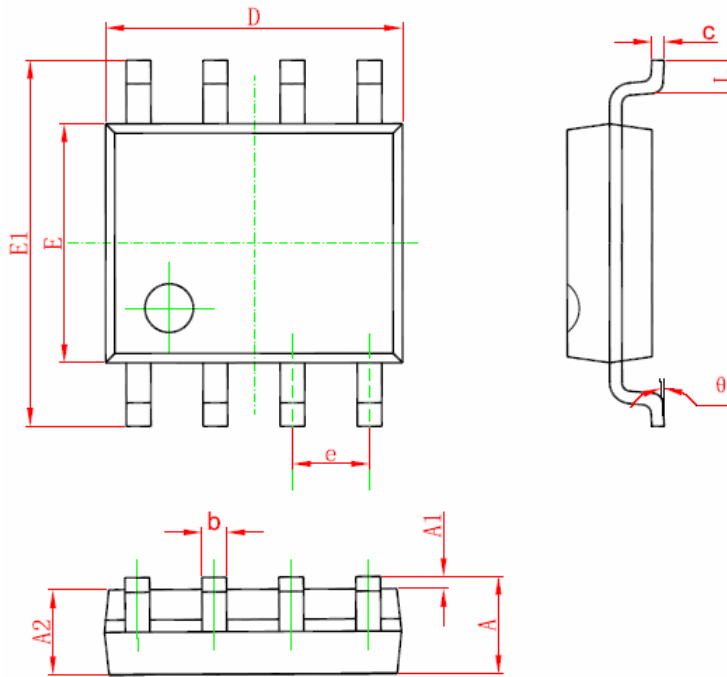

Symbol	Dimensions In Millimeters		Dimensions In Inches	
	Min	Max	Min	Max
A	1.350	1.750	0.053	0.069
A1	0.100	0.250	0.004	0.010
A2	1.350	1.550	0.053	0.061
b	0.330	0.510	0.013	0.020
c	0.170	0.250	0.006	0.010
D	4.700	5.100	0.185	0.200
E	3.800	4.000	0.150	0.157
E1	5.800	6.200	0.228	0.244
e	1.270 (BSC)		0.050 (BSC)	
L	0.400	1.270	0.016	0.050
θ	0°	8°	0°	8°

Design Notes