

**SHENZHEN SHILIN
ELECTRONICS CO., LTD.**

**PRODUCT
SPECIFICATION**

MODEL
TDQ6A

PAGE
1

DESCRIPTION
B/G,D/K,I,M/N

TDQ6A

FOR RF IN THE PC MULTI-MEDIA ENVIRONMENT
Desktop Video & FM Radio

CUSTOMER APPROVAL

A	Original Release		
REV.	DESCRIPTION	DATE	SIGN
DESCRIPTION Desktop Video tuner system B/G,D/K,I,M/N		APPROVAL DATE	CHECK DATE
DRAWING NO.		DESIGN DATE	
REVISIONS 1.0	PAGES TOTAL 20		

NO	ITEM	SPECIFICATION																																			
1.	GENERAL																																				
1. 1	Supply Voltage	True 5V device (low power dissipation)																																			
1. 2	Control system	I ² C bus control of tuning , address selection AFC status information																																			
1. 3	Tuning System	PLL controlled tuning																																			
1. 4	IF System	True – synchronous PLL vision IF demodulator																																			
1. 5	Receiving System	Systems PAL B/G,D/K,I, SECAM B/G,D/K, NTSC M/N FM																																			
1. 6	Receiving Channels	Full frequency range																																			
		<table border="1"> <thead> <tr> <th>BAND</th> <th>CHANNELS (MHz)</th> </tr> </thead> <tbody> <tr> <td>FM radio band</td> <td>87.5 to 108.00</td> </tr> <tr> <td>VHF LOW</td> <td>44.25 -140.25</td> </tr> <tr> <td>VHF HIGH</td> <td>147.25-423.25</td> </tr> <tr> <td>UHF</td> <td>431.25 - 863.25</td> </tr> </tbody> </table>	BAND	CHANNELS (MHz)	FM radio band	87.5 to 108.00	VHF LOW	44.25 -140.25	VHF HIGH	147.25-423.25	UHF	431.25 - 863.25																									
BAND	CHANNELS (MHz)																																				
FM radio band	87.5 to 108.00																																				
VHF LOW	44.25 -140.25																																				
VHF HIGH	147.25-423.25																																				
UHF	431.25 - 863.25																																				
1. 7	Intermediate Frequency	<table border="1"> <thead> <tr> <th rowspan="2">SYSTEM</th> <th colspan="5">FREQUENCY(MHz)(1)</th> </tr> <tr> <th>B/G</th> <th>D/K.</th> <th>I</th> <th>M/N</th> <th>FM</th> </tr> </thead> <tbody> <tr> <td>Picture</td> <td>38.90</td> <td>38.90</td> <td>38.90</td> <td>38.90</td> <td></td> </tr> <tr> <td>Colour</td> <td>34.47</td> <td>34.47</td> <td>34.47</td> <td>34.47</td> <td></td> </tr> <tr> <td>Sound 1</td> <td>33.40</td> <td>32.40</td> <td>32.90</td> <td>34.40</td> <td>10.7</td> </tr> <tr> <td>Sound 2</td> <td>33.16</td> <td>--</td> <td>--</td> <td></td> <td></td> </tr> </tbody> </table>	SYSTEM	FREQUENCY(MHz)(1)					B/G	D/K.	I	M/N	FM	Picture	38.90	38.90	38.90	38.90		Colour	34.47	34.47	34.47	34.47		Sound 1	33.40	32.40	32.90	34.40	10.7	Sound 2	33.16	--	--		
SYSTEM	FREQUENCY(MHz)(1)																																				
	B/G	D/K.	I	M/N	FM																																
Picture	38.90	38.90	38.90	38.90																																	
Colour	34.47	34.47	34.47	34.47																																	
Sound 1	33.40	32.40	32.90	34.40	10.7																																
Sound 2	33.16	--	--																																		
1. 8	Antenna Input Impedance	VHF/UHF: 75 ohm unbalanced																																			
1. 9	Output Impedance	Demodulator Video output: AF Sound output																																			
1. 10	Weight	Approximate: 20 grams																																			
1. 11	Connection	Antenna :pin																																			
	SYMBOL	PIN	DESCRIPTION																																		
	V _{OUT}	1	Composite Video Baseboard signal output																																		
	A _{OUT}	2	AF sound output																																		
	AFT	3	AFT OUT(FM)																																		
	RF AGC	4	RF AGC 4.0V IN(factory section)																																		
	+B	5	Supply Voltage : +5V																																		
	SIF	6	SIF OUT																																		
	SCL	7	I ² C-bus Serial clock																																		
	SDA	8	I ² C -bus Serial data																																		
	AS	9	I ² C -bus address select																																		
	BT	10	Tuning Voltage (factory section)																																		
	IF OUT	11	IF signal output																																		

NO	ITEM	SPECIFICATION					
1. 13	Operating Temp	-10℃ to +60℃: Standard +25℃					
1. 14	RH	0 to 90%: Standard 60%					
1. 15	Storage Temp	-20℃ to +80℃: Standard +25℃					
1. 16	Maximum Supply Voltage to terminal						
	SYMBOL	PARAMETER	PIN	MIN	TYP	MAX	UNIT
	Vs	Supply voltage	5	4.75	5.00	5.25	V
	Vs (ripple)	Peak-to-peak ripple voltage susceptibility (at 5V+5%): 20Hz to 100KHz >100KHz to 500KHz		--	--	20	mVp-p
				--	--	10	mVp-p
	Is	Supply current		--	--	120	mA
	Vscl	SCL-bus input Voltage	7	-0.3	--	+5.25	V
	VSDA	SDA-bus input Voltage	8	-0.3	--	+5.25	V
	ISDA	SDA-bus current open collector		+1	--	+5	mA
	VAS	Address select Voltage	9	--	--	+5.25	V
	ZIF	2ndIF Sound output load impedance DC AC	11	0.5	--	--	KΩ
				0.5	--	--	KΩ
	ZCVBS	Compile Video Baseboard signal load impedance: DC AC	1	--	75	--	Ω
				--	75	--	Ω
	Ti	Load dune constant		--	--	100	ns
	VIF	IF supply voltage		4.75	5.00	5.25	V
	VIF (ripple)	Peak-to-peak ripple voltage susceptibility (at 5V±5%) 20Hz to 100KHz >100KHz to 500KHz		--	--	20	mVp-p
				--	--	10	mVp-p
	IIF	IF supply carnet					100
	ZAF	AF Sound output load impedance DC AC	2	1.0	--	--	KΩ
				0.6	--	--	KΩ

NO	ITEM							
1. 17	Overall performance							
	SYMBOL	PARAMETER	VALUE	UNIT				
	Tamp	Ambient temperature	25±5	°C				
	RH	Relative humidity	60±5	%				
	V _S	Supply voltage	5±0.125	V				
	Z _{CVBS}	Video output load impedance	75	Ω				
	Z _{IF}	IF sound output load impedance	>500	Ω				
	TPR	Pre-heating tune: +5V at pin	40	mnule				
	Z _{SAF}	Aerial source impedance unbalance	75	Ω				
2.	ELECTRICAL CHARACTERISTICS							
NO	ITEM		SPECIFICATION					Notes
2. 1	V _{SWR}		Min	Typ	Max	Unit	Condition	
			--	--	5			
2. 2	Vant Radiation	0~1.75GHz			46	dBμ V	75Ω Terminate	
2. 3	Image rejection	VHF low VHF high UHF	51 55 46	70 70 55		dB		
2. 4	If rejection		60	--		dB		
2. 5	1/2 IF susceptibility off-air UHF		50 56	-- --		dB		
2. 6	Cross modulation		70	--		dBμ V		
2. 7	OSC Voltage at all pins		--	--	80	dBμ V		
2. 8	OSC lock-in time		--	--	150	ms		
2. 9	The Video signal-to-Sound interference ratio with the tuner exposed to sound dingles in the audio frequency range 100Hz to 10KHz and sound pressure levels up to 105dB		40	--	--	dB		
3.	Video and audio characteristics							
NO	ITEM	Test Point	Min	Type	Ma x	Uni t	Condition	Notes
3. 1	CVBS characteristics: Video amplitude signal at pin 8 DC level sync pulse at pin 8	1 1	0.7 --	-- 0.35	1.2 --	V V		

NO	ITEM	Test Point	MIN	TYPE	MAX	UNIT	CONDITION	NOTES
3. 2	Video amplitude drop with respect to modulation 0.1 MHz at Temp=45°C At 1MHz At 2MHz At 3MHz At 4MHz At 4.43MHz	1	-1.0 -1.5 -2.5 -3.0 -7.0	--	+1.0 +1.5 +1.5 +2.0 +3.0	dB		
3. 3	Sound carrier rejection	1	40	--	--	dB		
3. 4	CVBS S/N(outweighed)	1	44	--	--	dB		
3. 5	Gain limited sensitivity at 1dB reduction of Video output	1	--	--	30	dBμ V		
3. 6	Audio characteristics: AF output level measured via LP 20KHz filter RMS detector 50 us de-emphasis THD measured via LP 20KHz filter RMS detector 50 us de-emphasis S/N measured via filter peak detector 50 us de-emphasis	2	0.25 -- 44	0.35 --	0.5 0.5	V %		
3. 7	AF 3dB response measured via LP 20KHz filter RMS detector de-emphasis off	2	16	--	--	KHz		
3. 8	AM suppression ratio	2	40	--	--	dB		

4. Digital AFC Status

Parameter	Conditions	Frequency (KHz)	Digital read-out
	Input voltage at ADC:0.00 to 0.15 Vs	-125	00
ADC word at I2C bus	Input voltage at ADC :0.15 to 0.30 Vs	-62.5	01
During read operation	Input voltage at ADC:0.30 to 0.45 Vs	0	02
	Input voltage at ADC:0.45 to 0.60 Vs	+62.5	03
	Input voltage at ADC:0.60 to 1.00 Vs	+125	04

5. Application information (I²C -bus date format)

A detailed description of the I²C -bus specification with application, is gives in brochure “the I²C -bus and how to use it”,

BYTE	MSB	DATA BYTE						LSB	COMMAND
Address byte (ADB)	1	1	0	0	0	MA1	MA0	0	A
Divider byte (DB1)	0	N ₁₄	N ₁₃	N ₁₂	N ₁₁	N ₁₀	N ₉	N ₈	A
Divider byte (DB2)	N ₇	N ₆	N ₅	N ₄	N ₃	N ₂	N ₁	N ₀	A
Control byte (CB)	1	CP	T2	T1	T0	RSA	RSB	0	A
Ports byte (PB)	X	X	X	X	BS4	BS3	BS2	BS1	A

NOTE:

5. 1 A = Acknowledge
 5. 2 Address selection
 V_s = +5V(PLL supply voltage)

Voltage applied on as input	MA1	MA0	Address
0 to 0.1 V _s	0	0	C0 default
0.2 to 0.3 V _s	0	1	C2
0.4 to 0.6 V _s	1	0	C4
0.9 to 1 V _s	1	1	C8

5. 3 Divider ratio:
 $N=16*\{f_{RF}(pc) + f_{IF}(pc)\}$, where (pc) is picture carrier and f_{RF} and f_{IF} are expressed in MHz.
 $f_{osc}=N/16(\text{MHz})$
 $N=2^{14} \times N_{14} + 2^{13} \times N_{13} + 2^{12} \times N_{12} + \dots + 2^2 \times N_2 + 2^1 \times N_1 + 2^0 \times N_0$

5. 4 Ratio select bits

RSA	RSB	STEP SIZE
X	0	50KHz
0	1	31.25KHz(for slow picture search)
1	1	62.50KHz(for normal picture search)

5. 5 Band switching

BAND	BITE							
	X	X	X	X	BS4	BS3	BS2	BS1
FM	X	X	X	X	0	0	0	1
Low band	X	X	X	X	0	0	0	1
mid band	X	X	X	X	0	0	1	0
High band	X	X	X	X	1	0	0	0

NOTES:

- X = don't care BS1 to BS4 are output ports on the PLL device.
- BS3 is a system switch output for customer applications.

5. 6 Control Byte:

CP=0, Change pump current 60uA

CP=1, Change pump current 240uA(normal operation)

5. 7 Test mode settings:

T2=T1=0; T0=1 for normal operation.

5. 8 Write mode:

Start-Adb-Ack-Db1-Ack-Db2-Ack-cb-Ack-pb-Ack-Stop.

Start-Adb-Ack -cb-Ack-pb-Ack-Db1-Ack-Db2-Ack-Stop.

Start-Adb-Ack-Db1-Ack-Db2-Ack-cb-Ack-Stop.

Start-Adb-Ack-Db1-Ack-Db2-Ack-Stop.

Where:

Start = start condition Adb = address byte Ack = acknowledge

Db1 = divider byte1 Db2 = divider byte2 Cb = control byte

Pb = ports byte

Stop = stop condition

5. 9 READ mode:

The in-lock can be to read by setting the R/W bit to logical1.

BYTE	MSB	DATA BYTE						LSB	COMMAND
Address byte	1	1	0	0	0	MA1	MA0	1	A
Status byte	POR(1)	FL(2)	1	1	1	A2 ³	A1 ³	AO ³	A

NOTES:

1. POR = Power on Reset, POR=1 at power-on.

2. FL = In-lock flag, FL=1: loop is phase-locked.

3. A2 to A0=digital outputs of the 5-level ADC.

4. A = Acknowledge.

5. READ mode.

Start-Adb-Ack-STB-Ack-STROb2-stoping Ack form processor-End-of data.

Start-Adb-Ack-STB-stoping Ack form processor-End-of data.

Where:

STB = status bytes.

6 SIF/VIF I²C-CONTROL (TDA9885)

6.1 Read format

Table 1 I²C-bus read format(slave transmits data)

S	BYTE 1								A	BRTE 2								AN	P
	A6	A5	A4	A3	A2	A1	A0	R/W		D7	D6	D5	D4	D3	D2	D1	D0		
	Slave address								1	data									

Table 2 Explanation of Table 1

SYMBOL	FUNCTION
S	START condition, generated by the master
Slave address	100 001 1(first MAD)
R/W=1	Read command, generated by the master
A	Acknowledge bit, generated by the slave
Date	8-bit data word, transmitted by the slave
AN	Acknowledge-not bit, generated by the master
P	STOP condition, generated by the master

The master generates an acknowledge when it has received the data word READ. The master next generates an acknowledge, then slave begins transmitting the data word READ, and so on until the master generates an Acknowledge-not bit and transmits a STOP condition.

6.1.1 SLAVE ADDRESS

The first module address MAD1 is the standard address.

For applications without I²C-bus:see Tables 14 and 15.

6.1.2 DATA BYTE

Table 3 Data read register (status register)

MSB							BIT
LSB							
D7	D6	D5	D4	D3	D2	D1	D0
AFCWIN	RIFLEV	--	AFC4	AFC3	AFC2	AFC1	PONR

Table 4 Description of status register bits

BIT	VALUE	DESCRIPTION
AFCWIN	1	AFC window VCO in ± 1.6 MHZ AFC window. note 1
	0	VCO out of ± 1.6 MHZ AFC window
VIFLEV	1	VIF input level High level; VIF input voltage ≥ 200 Uv(typically)
	0	Low level
AFC4:1		Automatic frequency control See Table 5
PONR	1	Power-on reset After power-on reset or after supply breakdown
	0	After a successful reading of the status register

Note

1. if no IF input is applied, then bit AFCWIN=1 due to the fact that the VCO is forced to the AFC window border for fast load-in behaviour.

Table 5 Automatic frequency control; note 1

BIT				fvIF
AFC4	AFC3	AFC2	AFC1	
0	1	1	1	$\leq (f_p - 187.5\text{KHz})$
0	1	1	0	Fp-16 .5KHz
0	1	0	1	Fp-137.5KHz
0	1	0	0	Fp-112.5KHz
0	0	1	1	Fp-87.5KHz
0	0	1	0	Fp-62.5KHz
0	0	0	1	Fp-37.5KHz
0	0	0	0	Fp-12.5KHz
1	1	1	1	Fp+12.5KHz
1	1	1	0	Fp+37.5KHz
1	1	0	1	Fp+62.5KHz
1	1	0	0	Fp+87.5KHz
1	0	1	1	Fp+112.5KHz
1	0	1	0	Fp+137.5KHz
1	0	0	1	Fp+162.5KHz
1	0	0	0	$\geq (F_p + 187.5\text{KHz})$

Note

- 1.Fp is the nominal frequency of fvIF.

6.2 Write format

Table 6 I²C- bus write format(slave receives data);note 1

S	BYTE1		A	BYTE2	A	BYTE3	A	BYTE n	A	P
	A6 to A0	R/W		A7 to A0		Bits7 to 0		Bits 7 to 0		
	Slave address	0		sub address		Data 1		Data n		

Note

1. The auto-increment of the subaddress stops. if the subaddress is 3.

Table 7 Explanation of Table 6

SYMBOL	FUNCTION
S	START condition, generated by the master
Slave address	100 001 1
R/W=0	Write command, generated by the master
A	Acknowledge bit, generated by the slave
Subaddress(SAD)	See Table 8
Date 1,data n	8-bit data words, transmitted by the master(see Tables 9,10 and12
P	STOP condition

6.2.1 SUBADDRESS

If more than 1 data byte is transmitted, then auto-increment is performed: starting from the transmitted subaddress and auto-increment of subaddress in accordance with the order of Table 8.

Table 8 Definition of the subaddress (second byte after slave address);note 1

REGISTER	MSB LSB BIT							
	A7 ²	A6 ³	A5 ³	A4 ³	A3 ³	A2 ³	A1	A0
SAD for switching mode	0	×	×	×	×	×	0	0
SAD for adjust mode	0	×	×	×	×	×	0	1
SAD for data mode	0	×	×	×	×	×	1	0

Notes

- 1.x=don't care
- 2.Bit A7=1 is not allowed.
- 3.Bits A6 to A2 will be ignored by the internal hardware.

6.2.2 DATA BYTE FOR SWITCHING MODE

Table 9 Bit description of SAD register for switching mode(SAD=00)

BIT	VALUE	DESCRIPTION
7	1 0	Output port2 for SAW switching or monitoring High-impedance, disabled or HIGH Low-impedance, active or LOW
6	1 0	Output port 1 for SAW switching or external input High-impedance, disabled or HIGH Low-impedance, active or LOW
5	1 0	Forced audio mute On Off
4 and 3	00 01 10 11	TV standard modulation Positive AM TV(for positive AM TV choose 6.5MHz for second SIF) FM Negative FM TV FM
2	1 0	Carrier mode QSS mode Inter carrier mode
1	1 0	Mute of FM AF outputs Active Inactive
0	1 0	Video mode(sound trap) Sound trap bypass Sound trap active

6.2.3 DATA BYTE FOR ADJUST MODE

Table 10 Bit description of SAD register for adjust mode(SAD=01)

BIT	VALUE	DESCRIPTION
7	1 0	Audio gain -6Db 0dB
6	1 0	De-emphasis time constant 50us 75us
5	1 0	De-emphasis On off
4to0		Tuner takeover point adjustment See Table 11

Table 11 Tuner takeover point adjustment bits

BIT					TOP ADJUSTMENT (DB)
4	3	2	1	0	
1	1	1	1	1	+15
1	1	1	1	0	+14
1	1	1	0	1	+13
1	1	1	0	0	+12
1	1	0	1	1	+11
1	1	0	1	0	+10
1	1	0	0	1	+9
1	1	0	0	0	+8
1	0	1	1	1	+7
1	0	1	1	0	+6
1	0	1	0	1	+5
1	0	1	0	0	+4
1	0	0	1	1	+3
1	0	0	1	0	+2
1	0	0	0	1	+1
1	0	0	0	0	0
0	1	1	1	1	-1
0	1	1	1	0	-2
0	1	1	0	1	-3
0	1	1	0	0	-4
0	1	0	1	1	-5
0	1	0	1	0	-6
0	1	0	0	1	-7
0	1	0	0	0	-8
0	0	1	1	1	-9
0	0	1	1	0	-10
0	0	1	0	1	-11
0	0	1	0	0	-12
0	0	0	1	1	-13
0	0	0	1	0	-14
0	0	0	0	1	-15
0	0	0	0	0	-16

Note

1.0 dB is equal to 17mV(RMS).

6.2.4 DATA BYTE FOR DATA MODE

Table 12 Bit description of SAD register for data mode(SAD=10)

BIT	VALUE	DESCRIPTION
7		VIF-AGC output at pin OP2 Dependent on bits 5 and 1;see Table 13
6	1 0	L standard PLL gating HIGH Gating in case of 36% positive modulation Gating in case of 0% positive modulation
5		VIF,SIF and tuner minimum gain Dependent on bit 7;see Table 13
4 to 2	000 001 010 011 100 101 110 111	Standard frequency video IF FvIF=58.75MHz FvIF=45.75MHz FvIF=38.9MHz FvIF=38.0MHz FvIF=33.9MHz FvIF=33.4MHz Not used Not used
1 and 0	00 01 10 11	Standard frequency sound inter carrier(sound 2 nd IF) FFM=4.5MHz FFM =5.5MHz FFM =6.0MHz FFM =6.5MHz(for positive modulation choose 6.5 MHz)

Table 13 Options in extended TV mode bit3=0 of SAD 00 register

FUNCTION	BIT 7=0		BIT 7=1	
	BIT5=0	BIT5=1	BIT5=0	BIT5=1
Pin OP1	Port function	Port function	Port function	VIF-AGC external input
Pin OP2	Port function	Port function	VIF-AGC output	Port function
Gain	Normal gain	Minimum gain	Normal gain	External gain

Table 14 Data setting after power-on reset(default setting for MAD=0)

REGISTER	MSB								LSB
	D7	D6	D5	D4	D3	D2	D1	D0	
Switching mode	1	1	0	1	0	1	1	0	
Adjust mode	0	0	1	1	0	0	0	0	
Data mode	0	0	0	0	0	0	0	0	

Table 15 Data setting after power-on reset(default setting for MAD=1)

REGISTER	MSB								LSB
	D7	D6	D5	D4	D3	D2	D1	D0	
Switching mode	1	1	0	1	0	1	1	0	
Adjust mode	0	0	1	1	0	0	0	0	
Data mode	0	0	0	0	0	1	0	0	

For convenience, the programming has consolidated as a single table.

FUNCTION		MSB							LSB		Hex
		D7	D6	D5	D4	D3	D2	D1	D0		
Switching (B data)		0	0	0	1	0	1	1	0	0x16	
Adjust (C data)		0	0	1	1	0	0	0	0	0x30	
Data (E data)	NTSC M/N	0	0	0	0	1	0	0	0	0x08	

Description	Bits	TV System					Force audio mute
		B/G	I	D/K	M/N		
Video Trap Bypass	B0	0	0	0	0		X
Auto Mute FM	B1	1	1	1	1		X
Carrier Mode	B2	1	1	1	1		X
FM Mode	B3	0	0	0	0		X
TV Modulation	B4	1	1	1	1		X
Forced Mute Audio	B5	0	0	0	0		1
Not Used(OP1)	B6	0	0	0	0		X
Not Used (OP2)	B7	0	0	0	0		X
Top Adjustment	C0	0	0	0	0		X
	C1	0	0	0	0		X
	C2	1	1	1	0		X
	C3	0	0	0	0		X
	C4	1	1	1	1		X
De-Emphasis	C5	1	1	1	1		X
De-Emphasis Time	C6	1	1	1	0		X
Audio Gain	C7	0	0	0	0		X
Sound Intercarrier	E0	1	0	1	0		X
	E1	0	1	1	0		X
Video IF	E2	0	0	0	0		X
	E3	1	1	1	1		X
	E4	0	0	0	0		X
IF Gain	E5	0	0	0	0		X
L/L' PLL Gating	E6	0	0	0	0		X
VIF AGC Output	E7	0	0	0	0		0

System typical application

一、TV system

FUNCTION		MSB							LSB		Hex
		D7	D6	D5	D4	D3	D2	D1	D0		
Switching(B data)		0	0	0	1	0	1	1	0	0x16	
Adjust (C data)		0	1	1	1	0	0	0	0	0x70	
Data (E data)	D/K	0	0	0	0	1	0	1	1	0x0B	
	I	0	0	0	0	1	0	1	0	0x0A	
	B/G	0	0	0	0	1	0	0	1	0x09	

FUNCTION		MSB							LSB		Hex
		D7	D6	D5	D4	D3	D2	D1	D0		
Switching(B data)		0	0	0	1	0	1	1	0	0x16	
Adjust (C data)		0	0	1	1	0	0	0	0	0x30	
Data (E data)	M/N	0	0	0	0	1	0	0	0	0x08	

NOTE: 1、 First write the data of IF unit, then write the RF data.
2、 According to conditions of each channel and TV set, the AGC control data can be changed through I²C bus anytime. Then the best setup of each channel can be achieved.

Example : To tune to B/G (471.25 MHz) in high band

Fosc = 471.25 + 38.9 = 510.15 MHz N = (510.15 MHz) / (62.5 kHz) = 1F E2 (Hexadecimal)

DB1 = 1F H and DB2 = E2 H

CB = CE H

PB = 18 H (because of high band selected)

MSB Bit6 Bit5 Bit4 Bit3 Bit2 Bit1LSB										
Address										
ADB	1	1	0	0	0	MA1	MA0	RAW	= C0	
Write										
DB1	0	N14	N13	N12	N11	N10	N9	N8	= 1F	
DB2	N7	N6	N5	N4	N3	N2	N1	N0	= E2	
CB	1	CP	T2	T1	T0	RSA	RSB	OS	= CE	
BB	P8	P7	P6	P5	BS4	BS3	BS2	BS1	= 18	
Read										
SB	POR	FL	1	1	1	A2	A1	A0	= 00	
Close										

RF PROGRAM

MSB Bit6 Bit5 Bit4 Bit3 Bit2 Bit1LSB										
Address										
Slave	1	0	0	M1	0	1	M2	RAW	= 86	
Sub (SAD)	0	0	0	0	0	0	SAD1	SAD0	= 00	
Write										
Switching (B)	L	FMS	FMA	TVM	FM	CM	AMF	VM	= 16	
Adjust (C)	AG	DE1	DE0	TOP4	TOP3	TOP2	TOP1	TOP0	= 70	
Data (E)	AGC	Gate	GIF	VIF2	VIF1	VIF0	SIF1	SIF0	= 09	
Read										
Status (SR)	AFCW	VIFL	FMIFL	AFC4	AFC3	AFC2	AFC1	POR	= 00	
Close										

IF PROGRAM

B/G Vision IF=38.90MHz sound IF=33.40MHz

FREQUENCY TABLE(B/G)

UNIT: MHz

BAND	CHANNEL NO.	PICTURE FREQ.	SOUND FREQ.	LOCAL OSC FREQ.	IMAGE FREQ.
VHF LOW	1	48.25	53.75	87.15	126.05
	2	55.25	60.75	94.15	133.05
	3	62.25	67.75	101.15	140.05
	4	69.25	74.75	108.15	147.05
	5	76.25	81.75	115.15	154.05
	6	83.25	88.75	122.15	161.05
	7	90.25	95.75	129.15	168.05
	8	97.25	102.75	136.15	175.05
	9	105.25	110.75	144.15	183.05
	10	112.25	117.75	151.15	190.05
	11	119.25	124.75	158.15	197.05
	12	126.25	131.75	165.15	204.05
	13	133.25	138.75	172.15	211.05
	14	140.25	145.75	179.15	218.05
VHF HIGH	15	147.25	152.75	186.15	225.05
	16	154.25	159.75	193.15	232.05
	17	161.25	166.75	200.15	239.05
	18	168.25	173.25	207.15	246.05
	19	175.25	180.75	214.15	253.05
	20	182.25	187.75	221.15	260.05
	21	189.25	194.75	228.15	267.05
	22	196.25	201.75	235.15	274.05
	23	203.25	208.75	242.15	281.05
	24	210.25	215.75	249.15	288.05
	25	217.25	222.75	256.15	295.05
	26	224.25	229.75	263.15	302.05
	27	231.25	236.75	270.15	309.05
	28	238.25	243.75	277.15	316.05
	29	245.25	250.75	284.15	323.05
	30	252.25	257.75	291.15	330.05
	31	259.25	264.75	298.15	337.05
	32	266.25	271.75	305.15	344.05
	33	273.25	278.75	312.15	351.05
	34	280.25	285.75	319.15	358.05

B/G Vision IF=38.90MHz sound IF=33.40MHz

FREQUENCY TABLE (B/G)

UNIT: MHz

BAND	CHANNEL NO.	PICTURE FREQ.	SOUND FREQ.	LOCAL OSC FREQ.	IMAGE FREQ.
VHF HIGH	35	287.25	292.75	326.15	365.05
	36	294.25	299.75	333.15	372.05
	37	303.25	308.75	342.15	381.05
	38	311.25	316.75	350.15	389.05
	39	319.25	324.75	358.15	397.05
	40	327.25	332.75	366.15	405.05
	41	335.25	340.75	374.15	413.05
	42	343.25	348.75	382.15	421.05
	43	351.25	356.75	390.15	429.05
	44	359.25	364.75	398.15	437.05
	45	367.25	372.75	406.15	445.05
	46	375.25	380.75	414.15	453.05
	47	383.25	388.75	422.15	461.05
	48	391.25	396.75	430.15	469.05
	49	399.25	404.75	438.15	477.05
	50	407.25	412.75	446.15	485.05
	51	415.25	420.75	454.15	493.05
	52	423.25	428.75	462.15	501.05
UHF	53	431.25	436.75	470.15	509.05
	54	439.25	444.75	478.15	517.05
	55	447.25	452.75	486.15	525.05
	56	455.25	460.75	494.15	533.05
	57	463.25	468.75	502.15	541.05
	121	471.25	476.75	510.15	549.05
	122	479.25	484.75	518.15	557.05
	123	487.25	492.75	526.15	565.05
	124	495.25	500.75	534.15	573.05
	125	503.25	508.75	542.15	581.05
	126	511.25	516.75	550.15	589.05
	127	519.25	524.75	558.15	597.05
	128	527.25	532.75	566.15	605.05
	129	535.25	540.75	574.15	613.05
	130	543.25	548.75	582.15	621.05
	131	551.25	556.75	590.15	629.05
132	559.25	564.75	598.15	637.05	
133	567.25	572.75	606.15	645.05	

B/G Vision IF=38.90MHz sound IF=33.40MHz

FREQUENCY TABLE (B/G)

UNIT: MHz

BAND	CHANNEL NO.	PICTURE FREQ.	SOUND FREQ.	LOCAL OSC FREQ.	IMAGE FREQ.
UHF	134	575.25	580.75	614.15	653.05
	135	583.25	588.75	622.15	661.05
	136	591.25	596.75	630.15	669.05
	137	599.25	604.75	638.15	677.05
	138	607.25	612.75	646.15	685.05
	139	615.25	620.75	654.15	693.05
	140	623.25	628.75	662.15	701.05
	141	631.25	636.75	670.15	709.05
	142	639.25	644.75	678.15	717.05
	143	647.25	652.75	686.15	725.05
	144	655.25	660.75	694.15	733.05
	145	663.25	668.75	702.15	741.05
	146	671.25	676.75	710.15	749.05
	147	679.25	684.75	718.15	757.05
	148	687.25	692.75	726.15	765.05
	149	695.25	700.75	734.15	773.05
	150	703.25	708.75	742.15	781.05
	151	711.25	716.75	750.15	789.05
	152	719.25	724.75	758.15	797.05
	153	727.25	732.75	766.15	805.05
	154	735.25	740.75	774.15	813.05
	155	743.25	748.75	782.15	821.05
	156	751.25	756.75	790.15	829.05
	157	759.25	764.75	798.15	837.05
	158	767.25	772.75	806.15	845.05
	159	775.25	780.75	814.15	853.05
	160	783.25	788.75	822.15	861.05
	161	791.25	796.75	830.15	869.05
	162	799.25	804.75	838.15	877.05
	163	807.25	812.75	846.15	885.05
	164	815.25	820.75	854.15	893.05
	165	823.25	828.75	862.15	901.05
166	831.25	836.75	870.15	909.05	
167	839.25	844.75	878.15	917.05	
168	847.25	852.75	886.15	925.05	
169	855.25	860.75	894.15	933.05	
170	863.25	868.75	902.15	941.05	

unit mm

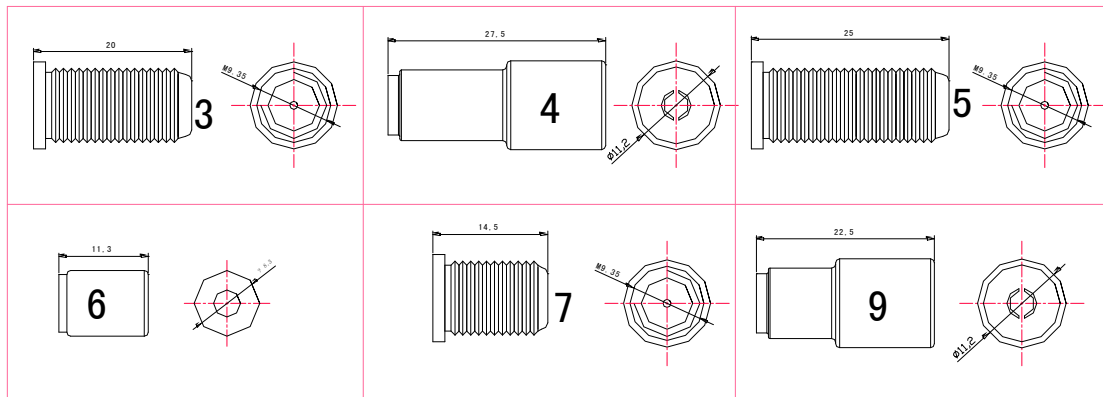
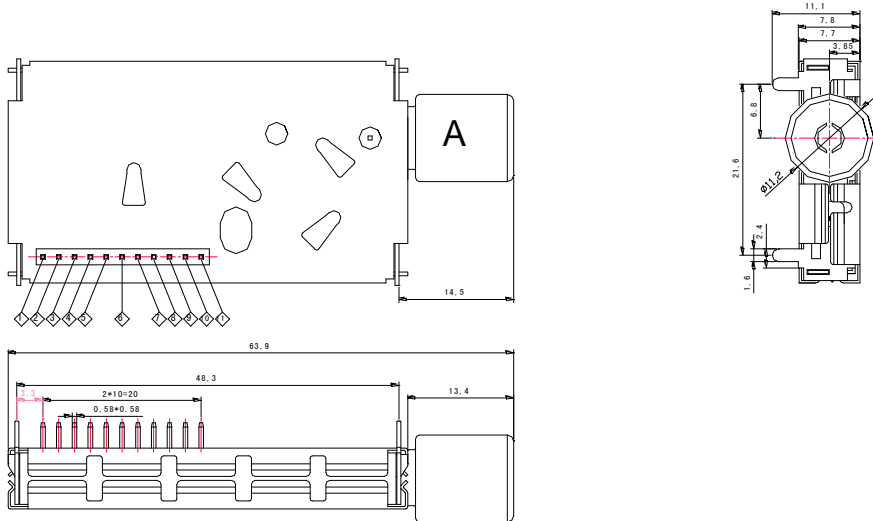

note: tolerances are ± 0.3 , unless otherwise specified.

SYMBOL	PIN	DESCRIPTION
V _{OUT}	1	Composite Video Baseboard signal output
A _{OUT}	2	AF sound output
AFT	3	AFT OUT(FM)
RF AGC	4	RF AGC 4.0V IN(factory section)
+B	5	Supply Voltage : +5V
SIF	6	SIF OUT
SCL	7	I ² C-bus Serial clock
SDA	8	I ² C -bus Serial data
AS	9	I ² C -bus address select
BT	10	Tuning Voltage (factory section)
IF OUT	11	IF signal output