

TEA1622P

STARplug™

Rev. 01 — 17 March 2004

Product data sheet

1. General description

The TEA1622P is a Switched Mode Power Supply (SMPS) controller IC that operates directly from the rectified universal mains. It is implemented in the high voltage EZ-HV™ SOI process, combined with a low voltage BICMOS process.

The device includes a high voltage power switch and a circuit for start-up directly from the rectified mains voltage. A dedicated circuit for valley switching is built in, which makes a very efficient slim-line electronic power-plug concept possible.

In its most basic version of application, the TEA1622P acts as a voltage source. Here, no additional secondary electronics are required. A combined voltage and current source can be realized with minimum costs for external components. Implementation of the TEA1622P renders an efficient and low cost power supply system.

2. Features

- Designed for general purpose supplies
- Integrated power switch: 12 Ω and 650 V
- Operates from universal AC mains supplies: 80 V to 276 V
- Adjustable frequency for flexible design
- RC oscillator for load insensitive regulation loop constant
- Valley switching for minimum switch-on loss
- Frequency reduction at low power output for low standby power: <100 mW
- Adjustable overcurrent protection
- Undervoltage protection
- Temperature protection
- Short winding protection
- Safe restart mode for system fault conditions
- Simple application with both primary and secondary (opto) feedback
- Available in 8-pin DIP package.

3. Applications

- Adapters
- Set-Top Box (STB)
- DVD
- VCD
- CD(R)
- PC Silverbox standby SMPS.

4. Quick reference data

Table 1: Quick reference data

Symbol	Parameter	Conditions	Min	Typ	Max	Unit
$V_{CC(max)}$	maximum supply voltage		-	-	40	V
$V_{DRAIN(max)}$	maximum voltage at pin DRAIN	$T_j > 0\text{ °C}$	-	-	650	V
I_{DRAIN}	supply current drawn from pin DRAIN	no auxiliary supply	-	0.5	-	mA
R_{DSon}	drain-source on-state resistance	$I_{SOURCE} = -0.25\text{ A}$				
		$T_j = 25\text{ °C}$	-	12	13.8	Ω
		$T_j = 100\text{ °C}$	-	17	19.6	Ω
f_{osc}	oscillator frequency range		10	-	200	kHz
T_{amb}	ambient temperature		-20	-	+85	$^{\circ}\text{C}$

5. Ordering information

Table 2: Ordering information

Type number	Package		
	Name	Description	Version
TEA1622P	DIP8	plastic dual in-line package; 8 leads (300 mil)	SOT97-1

6. Block diagram

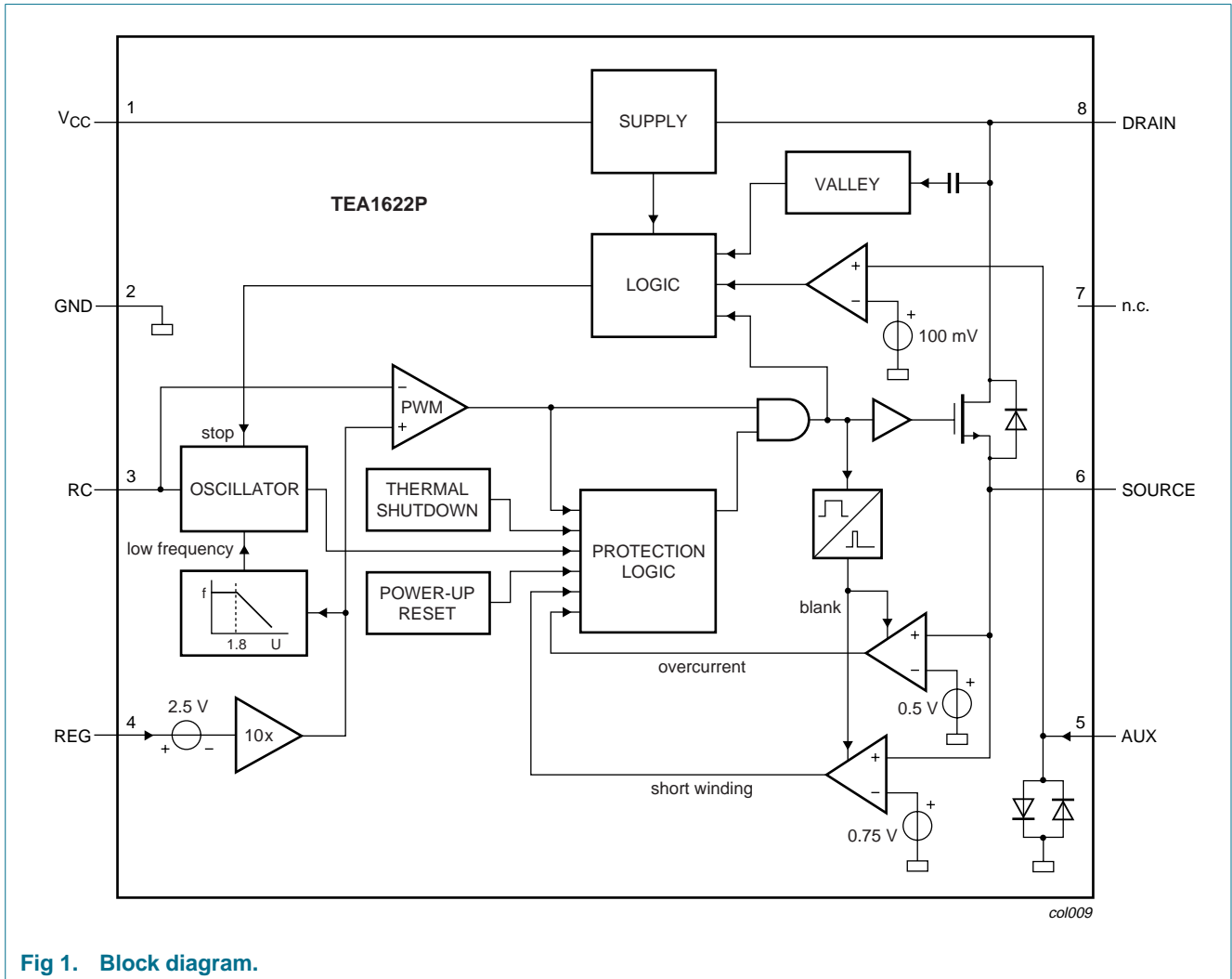

Fig 1. Block diagram.

7. Pinning information

7.1 Pinning

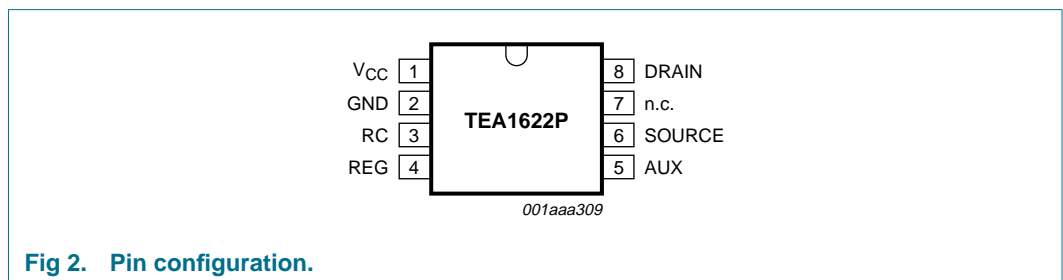

Fig 2. Pin configuration.

7.2 Pin description

Table 3: Pin description

Symbol	Pin	Description
V_{CC}	1	supply voltage
GND	2	ground
RC	3	frequency setting
REG	4	regulation input
AUX	5	input for voltage from auxiliary winding for timing (demagnetization)
SOURCE	6	source of internal MOS switch
n.c.	7	not connected
DRAIN	8	drain of internal MOS switch; input for start-up current and valley sensing

8. Functional description

The TEA1622P is the heart of a compact flyback converter, with the IC placed at the primary side. The auxiliary winding of the transformer can be used for indirect feedback to control the isolated output. This additional winding also powers the IC. A more accurate control of the output voltage and/or current can be implemented with an additional secondary sensing circuit and optocoupler feedback.

The TEA1622P uses voltage mode control. The frequency is determined by the maximum transformer demagnetizing time and the time of the oscillator. In the first case, the converter operates in the Self Oscillating Power Supply (SOPS) mode. In the latter case, it operates at a constant frequency, which can be adjusted with external components R_{RC} and C_{RC} . This mode is called Pulse Width Modulation (PWM). Furthermore, a primary stroke is started only in a valley of the secondary ringing. This valley switching principle minimizes capacitive switch-on losses.

8.1 Start-up and undervoltage lock-out

Initially, the IC is self supplying from the rectified mains voltage. The IC starts switching as soon as the voltage on pin V_{CC} passes the $V_{CC(start)}$ level. The supply is taken over by the auxiliary winding of the transformer as soon as V_{CC} is high enough and the supply from the line is stopped for high efficiency operation.

As soon as the voltage on pin V_{CC} drops below the $V_{CC(stop)}$ level, the IC stops switching and restarts from the rectified mains voltage.

8.2 Oscillator

The frequency of the oscillator is set by the external resistor and capacitor on pin RC. The external capacitor is charged rapidly to the $V_{RC(max)}$ level and, starting from a new primary stroke, it discharges to the $V_{RC(min)}$ level. Because the discharge is exponential, the relative sensitivity of the duty factor to the regulation voltage at low duty factor is almost equal to the sensitivity at high duty factors. This results in a more constant gain over the duty factor range compared to PWM systems with a linear sawtooth oscillator. Stable operation at low duty factors is easily realized. For high efficiency, the frequency is reduced as soon as the duty factor drops below a certain value. This is accomplished by increasing the oscillator charge time.

To ensure that the capacitor can be charged within the charge time, the value of the oscillator capacitor should be limited to approximately 1 nF.

8.3 Duty factor control

The duty factor is controlled by the internal regulation voltage and the oscillator signal on pin RC. The internal regulation voltage is equal to the external regulation voltage (minus 2.5 V) multiplied by the gain of the error amplifier (typical 20 dB or 10 ×).

The minimum duty factor of the switched mode power supply is 0 %. The maximum duty factor is set to 75 % (typical value at 100 kHz oscillation frequency).

8.4 Valley switching

A new cycle is started at the primary stroke when the switch is switched on (see [Figure 3](#)). After a certain time (determined by the RC oscillator voltage and the internal regulation level), the switch is turned off and the secondary stroke starts. The internal regulation level is determined by the voltage on pin REG. After the secondary stroke, the drain voltage shows an oscillation with a frequency of approximately $\frac{1}{2\pi \times \sqrt{L_p C_p}}$

Where:

L_p is the primary self inductance on the drain node

C_p is the parasitic capacitance on the drain node.

As soon as the oscillator voltage is high again and the secondary stroke has ended, the circuit waits for a low drain voltage before starting a new primary stroke.

The primary stroke starts some time before the actual valley at low ringing frequencies, and some time after the actual valley at high ringing frequencies. [Figure 4](#) shows a typical curve for a reflected voltage $N \times V_o$ of 80 V. This voltage is the output voltage V_o (see [Figure 5](#)) transferred to the primary side of the transformer with the factor N (determined by the turns ratio of the transformer). [Figure 4](#) shows that the system switches exactly at minimum drain voltage for ringing frequencies of 480 kHz, thus reducing the switch-on losses to a minimum. At 200 kHz, the next primary stroke is started at 33° before the valley. The switch-on losses are still reduced significantly.

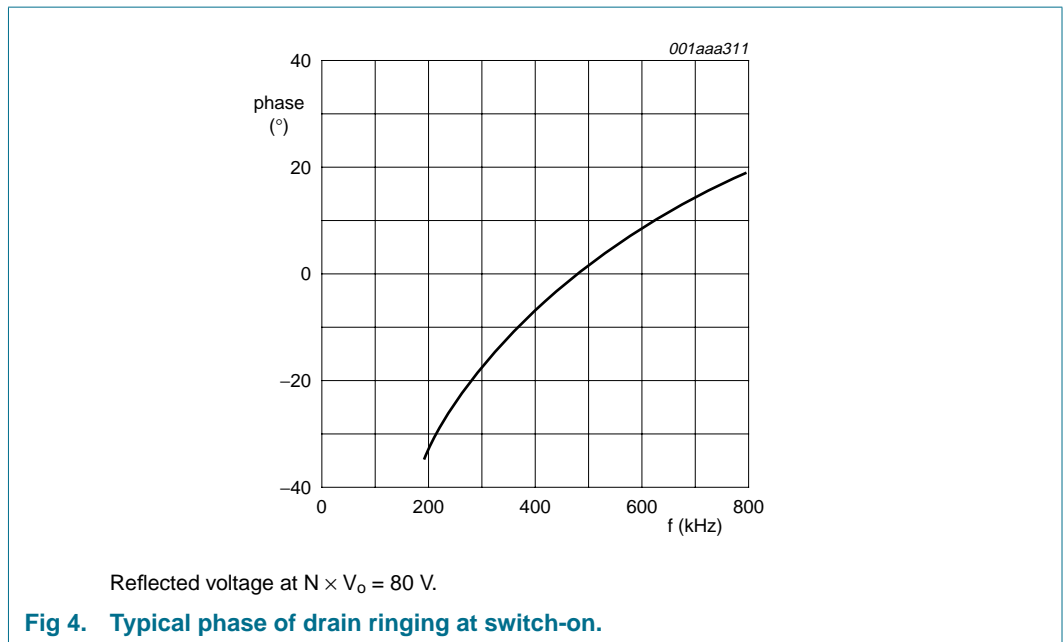
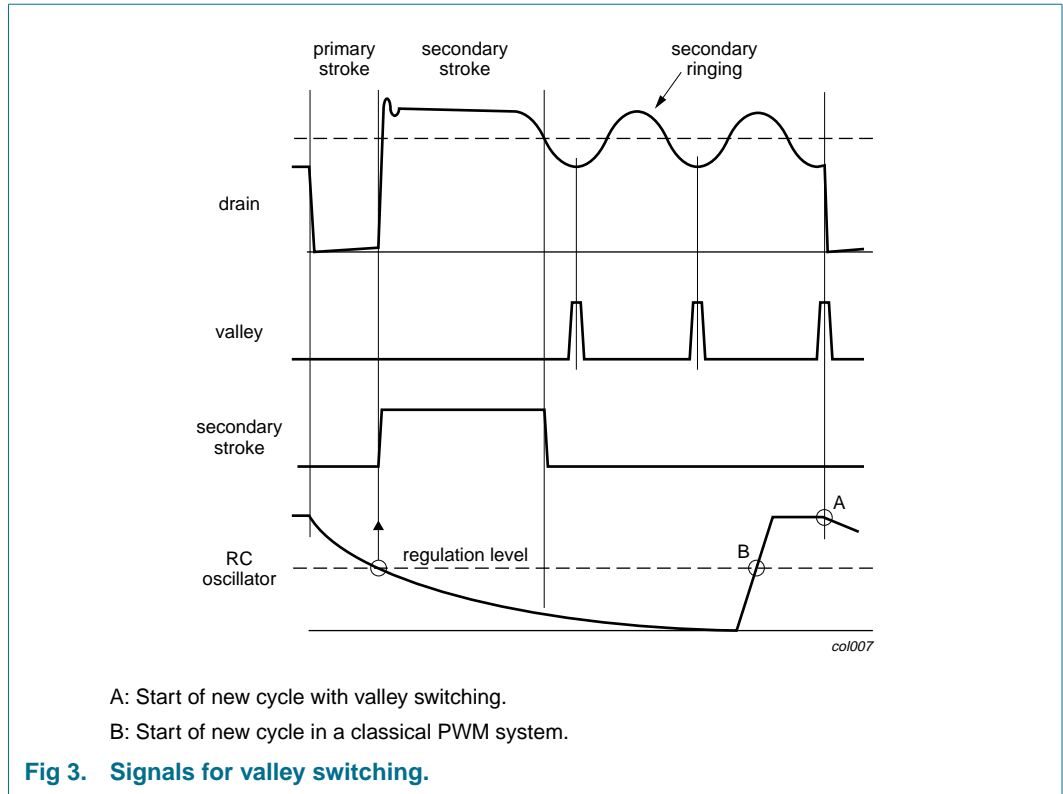

8.5 Demagnetization

The system operates in discontinuous conduction mode all the time. As long as the secondary stroke has not ended, the oscillator will not start a new primary stroke. During the suppression time t_{suppr} , demagnetization recognition is suppressed. This suppression may be necessary in applications where the transformer has a large leakage inductance and at low output voltages.

8.6 Protections

8.6.1 Overcurrent protection

The cycle-by-cycle peak drain current limit circuit uses the external source resistor R_I (see [Figure 5](#)) to measure the current. The circuit is activated after the leading edge blanking time t_{leb} . The protection circuit limits the source voltage to $V_{\text{source(max)}}$, and thus limits the primary peak current.

8.6.2 Short winding protection

The short winding protection circuit is also activated after the leading edge blanking time. If the source voltage exceeds the short winding protection voltage V_{swp} , the TEA1622P stops switching. Only a power-on reset will restart normal operation. The short winding protection also protects in case of a secondary diode short circuit.

8.6.3 Overtemperature protection

An accurate temperature protection is provided in the TEA1622P. When the junction temperature exceeds the thermal shutdown temperature, the IC stops switching. During thermal protection, the IC current is lowered to the start-up current. The IC continues normal operation as soon as the overtemperature situation has disappeared.

8.6.4 Overvoltage protection

Overvoltage protection can be achieved in the application by pulling pin REG above its normal operation level, or by keeping the level of pin AUX above V_{demag} . The current primary stroke is terminated immediately, and no new primary stroke is started until the voltage on pin REG drops to its normal operation level. Pin REG has an internal clamp. The current feed into pin REG must be limited.

8.7 Characteristics of the complete power-plug

8.7.1 Input

The input voltage range comprises the universal AC mains from 80 V to 276 V.

8.7.2 Accuracy

The accuracy of the complete converter, functioning as a voltage source with primary sensing, is approximately 8 % (mainly dependent on the transformer coupling). The accuracy with secondary sensing is defined by the accuracy of the external components. For safety requirements in case of optocoupler feedback loss, the primary sensing remains active when an overvoltage circuit is connected.

8.7.3 Efficiency

An efficiency of 75 % at maximum output power can be achieved for a complete converter designed for universal mains.

8.7.4 Ripple

A minimum ripple is obtained in a system designed for a maximum duty factor of 50 % under normal operating conditions, and a minimized dead time. The magnitude of the ripple in the output voltage is determined by the frequency and duty factor of the converter, the output current level, and the value and ESR of the output capacitor.

9. Limiting values

Table 4: Limiting values

In accordance with the Absolute Maximum Rating System (IEC 60134).

Symbol	Parameter	Conditions	Min	Max	Unit	
Voltages						
V_{CC}	supply voltage	continuous	[1] -0.4	+40	V	
V_{RC}	oscillator input voltage		[1] -0.4	+3	V	
V_{SOURCE}	DMOS power transistor source voltage		-0.4	+5	V	
V_{DRAIN}	DMOS power transistor drain voltage		-0.4	+650	V	
Currents						
I_{REG}	regulation input current		[2] -	6	mA	
I_{AUX}	auxiliary winding input current		[2] -10	+5	mA	
I_{RC}	oscillator capacitor charge current		-3	-	mA	
I_{SOURCE}	source current		-1	+1	A	
I_{DRAIN}	drain current		-1	+1	A	
General						
P_{tot}	total power dissipation	$T_{amb} < 45\text{ °C}$	-	1.0	W	
T_{stg}	storage temperature		-55	+150	°C	
T_{amb}	ambient temperature		-20	+85	°C	
T_j	junction temperature		-20	+145	°C	
V_{esd}	electrostatic discharge voltage	human body model	[3]			
		pin DRAIN		-1000	+1000	V
		all other pins		-2000	+2000	V
		machine model	[4]			
		all pins		-200	+200	V

[1] Pins V_{CC} and RC are not allowed to be current driven.

[2] Pins REG and AUX are not allowed to be voltage driven.

[3] Human body model: equivalent to discharging a 100 pF capacitor through a 1.5 k Ω series resistor.

[4] Machine model: equivalent to discharging a 200 pF capacitor through a 0.75 μ H coil and a 10 Ω series resistor.

10. Thermal characteristics

Table 5: Thermal characteristics

Symbol	Parameter	Conditions	Typ	Unit
$R_{th(j-a)}$	thermal resistance from junction to ambient	in free air	[1] 100	K/W

[1] Thermal resistance $R_{th(j-a)}$ can be lower when pin GND is connected to sufficient copper area on the printed-circuit board. See the TEA152x application notes for details.

11. Characteristics

Table 6: Characteristics

$T_{amb} = 25\text{ °C}$; no overtemperature; all voltages are measured with respect to ground; currents are positive when flowing into the IC; unless otherwise specified.

Symbol	Parameter	Conditions	Min	Typ	Max	Unit
Supplies						
Supply on pin V_{CC}						
$V_{CC(start)}$	start voltage		9	9.5	10	V
$V_{CC(stop)}$	stop voltage	undervoltage lock-out	7.0	7.5	8.0	V
$I_{CC(operate)}$	operating supply current	normal operation	-	1.3	1.9	mA
$I_{CC(startup)}$	start-up supply current	start-up	-	180	400	μ A
$I_{CC(ch)}$	charging current	$V_{DRAIN} > 60\text{ V}$				
		$V_{CC} = 0\text{ V}$	-650	-520	-390	μ A
		$V_{CC} = 8.5\text{ V}$	-375	-275	-175	μ A
Supply on pin DRAIN						
I_{DRAIN}	supply current drawn from pin DRAIN	no auxiliary supply	-	0.5	-	mA
		with auxiliary supply; $V_{DRAIN} > 60\text{ V}$	-	30	125	μ A
Pulse width modulator mode						
δ_{min}	minimum duty factor		-	0	-	%
δ_{max}	maximum duty factor	$f_{osc} = 100\text{ kHz}$	-	75	-	%
Self oscillating power supply mode						
V_{demag}	demagnetization recognition voltage level		50	100	150	mV
t_{suppr}	time of suppression of transformer ringing at start of secondary stroke		1.0	1.5	2.0	μ s
Oscillator: pin RC						
$V_{RC(min)}$	minimum voltage of RC oscillator setting		60	75	90	mV
$V_{RC(max)}$	maximum voltage of RC oscillator setting		2.4	2.5	2.6	V
$t_{RC(ch)}$	RC charging time		-	1	-	μ s
f_{osc}	oscillator frequency range		10	-	200	kHz
Duty factor regulator: pin REG						
V_{REG}	input voltage on pin REG		2.4	2.5	2.6	V

Table 6: Characteristics ...continued

$T_{amb} = 25\text{ °C}$; no overtemperature; all voltages are measured with respect to ground; currents are positive when flowing into the IC; unless otherwise specified.

Symbol	Parameter	Conditions	Min	Typ	Max	Unit
$G_{V(\text{erroramp})}$	voltage gain of error amplifier		-	20	-	dB
$V_{REG(\text{clamp})}$	clamping voltage on pin REG	$I_{REG} = 6\text{ mA}$	-	-	7.5	V
Valley switching recognition						
dV/dt_{valley}	valley recognition		-102	-	+102	V/μs
f_{valley}	ringing frequency for valley switching	$N \times V_o = 100\text{ V}$	200	550	800	kHz
$t_{d(\text{valley-on})}$	delay from valley recognition to switch-on		-	150	-	ns
Output stage (FET)						
$I_{L(\text{drain})}$	drain leakage current	$V_{DRAIN} = 650\text{ V}$	-	-	125	μA
$V_{BR(\text{drain})}$	drain breakdown voltage	$T_j > 0\text{ °C}$	650	-	-	V
R_{DSon}	drain-source on-state resistance	$I_{SOURCE} = -0.06\text{ A}$				
		$T_j = 25\text{ °C}$	-	12	13.8	Ω
		$T_j = 100\text{ °C}$	-	17	19.6	Ω
$t_{\text{drain}(f)}$	drain fall time	$V_{DRAIN(\text{switch-on})} = 300\text{ V}$; no external capacitor at pin DRAIN	-	75	-	ns
Temperature protection						
$T_{\text{prot}(\text{max})}$	maximum threshold temperature		150	160	170	°C
$T_{\text{prot}(\text{hys})}$	threshold temperature hysteresis		-	2	-	°C
Overcurrent and short winding protection: pin SOURCE						
$V_{\text{source}(\text{max})}$	overcurrent protection voltage	$dV/dt = 0.1\text{ V}/\mu\text{s}$	0.47	0.50	0.53	V
V_{swp}	short winding protection voltage	$dV/dt = 0.5\text{ V}/\mu\text{s}$	0.7	0.75	0.8	V
$t_{d(\text{propagation})}$	delay from detecting $V_{\text{source}(\text{max})}$ to switch-off	$dV/dt = 0.5\text{ V}/\mu\text{s}$	-	160	185	ns
t_{leb}	leading edge blanking time	both overcurrent and short winding protection	250	350	450	ns

12. Application information

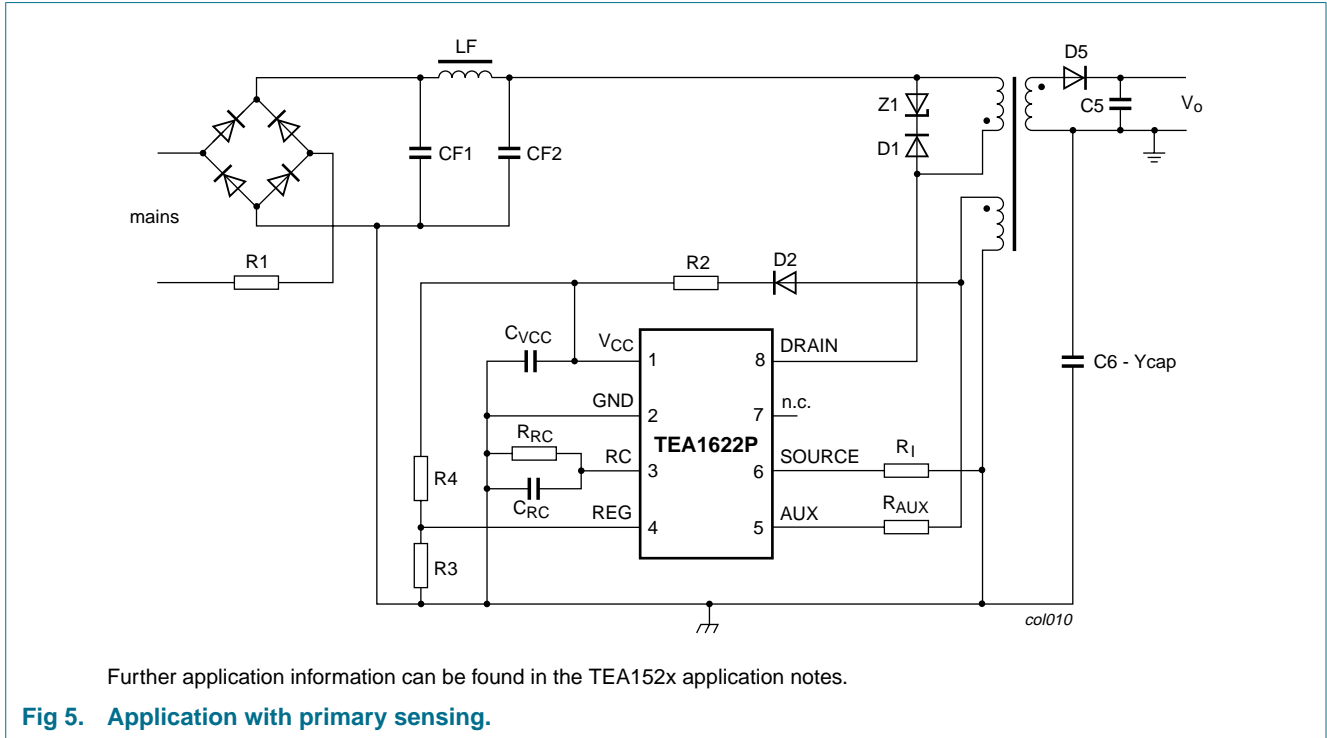

13. Test information

13.1 Quality information

The *General Quality Specification for Integrated Circuits*, SNW-FQ-611 is applicable.

14. Package outline

DIP8: plastic dual in-line package; 8 leads (300 mil)

SOT97-1

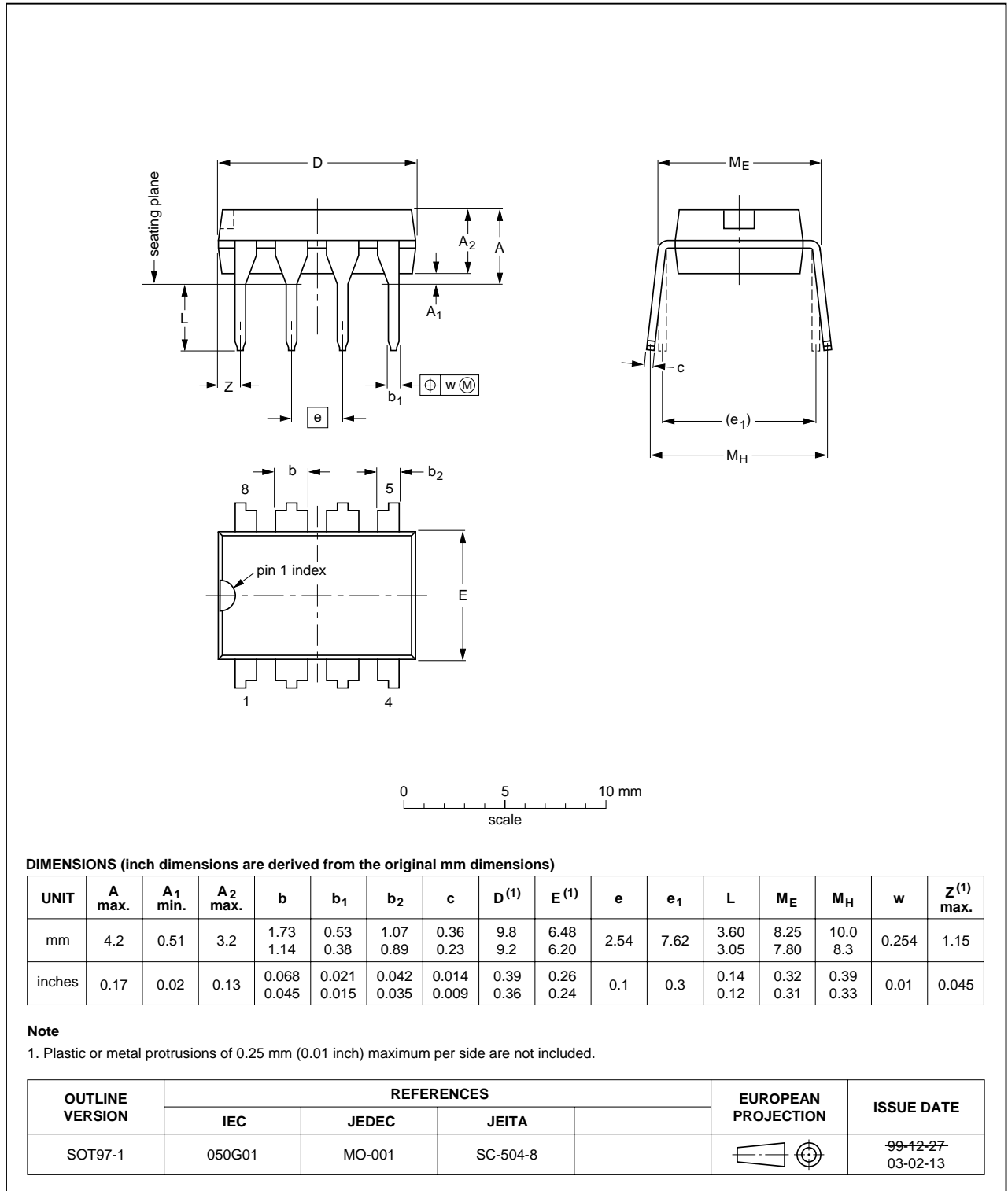

www.DataSheet4U.com
Fig 6. Package outline.

15. Soldering

15.1 Introduction to soldering through-hole mount packages

This text gives a brief insight to wave, dip and manual soldering. A more in-depth account of soldering ICs can be found in our *Data Handbook IC26; Integrated Circuit Packages* (document order number 9398 652 90011).

Wave soldering is the preferred method for mounting of through-hole mount IC packages on a printed-circuit board.

15.2 Soldering by dipping or by solder wave

Driven by legislation and environmental forces the worldwide use of lead-free solder pastes is increasing. Typical dwell time of the leads in the wave ranges from 3 to 4 seconds at 250 °C or 265 °C, depending on solder material applied, SnPb or Pb-free respectively.

The total contact time of successive solder waves must not exceed 5 seconds.

The device may be mounted up to the seating plane, but the temperature of the plastic body must not exceed the specified maximum storage temperature ($T_{stg(max)}$). If the printed-circuit board has been pre-heated, forced cooling may be necessary immediately after soldering to keep the temperature within the permissible limit.

15.3 Manual soldering

Apply the soldering iron (24 V or less) to the lead(s) of the package, either below the seating plane or not more than 2 mm above it. If the temperature of the soldering iron bit is less than 300 °C it may remain in contact for up to 10 seconds. If the bit temperature is between 300 and 400 °C, contact may be up to 5 seconds.

15.4 Package related soldering information

Table 7: Suitability of through-hole mount IC packages for dipping and wave soldering methods

Package	Soldering method	
	Dipping	Wave
DBS, DIP, HDIP, RDBS, SDIP, SIL	suitable	suitable ^[1]
PMFP ^[2]	–	not suitable

[1] For SDIP packages, the longitudinal axis must be parallel to the transport direction of the printed-circuit board.

[2] For PMFP packages hot bar soldering or manual soldering is suitable.



16. Revision history

Table 8: Revision history

Document ID	Release date	Data sheet status	Change notice	Order number	Supersedes
TEA1622P_1	20040317	Product data	-	9397 750 12578	-

17. Data sheet status

Level	Data sheet status ^[1]	Product status ^[2] ^[3]	Definition
I	Objective data	Development	This data sheet contains data from the objective specification for product development. Philips Semiconductors reserves the right to change the specification in any manner without notice.
II	Preliminary data	Qualification	This data sheet contains data from the preliminary specification. Supplementary data will be published at a later date. Philips Semiconductors reserves the right to change the specification without notice, in order to improve the design and supply the best possible product.
III	Product data	Production	This data sheet contains data from the product specification. Philips Semiconductors reserves the right to make changes at any time in order to improve the design, manufacturing and supply. Relevant changes will be communicated via a Customer Product/Process Change Notification (CPCN).

[1] Please consult the most recently issued data sheet before initiating or completing a design.

[2] The product status of the device(s) described in this data sheet may have changed since this data sheet was published. The latest information is available on the Internet at URL <http://www.semiconductors.philips.com>.

[3] For data sheets describing multiple type numbers, the highest-level product status determines the data sheet status.

18. Definitions

Short-form specification — The data in a short-form specification is extracted from a full data sheet with the same type number and title. For detailed information see the relevant data sheet or data handbook.

Limiting values definition — Limiting values given are in accordance with the Absolute Maximum Rating System (IEC 60134). Stress above one or more of the limiting values may cause permanent damage to the device. These are stress ratings only and operation of the device at these or at any other conditions above those given in the Characteristics sections of the specification is not implied. Exposure to limiting values for extended periods may affect device reliability.

Application information — Applications that are described herein for any of these products are for illustrative purposes only. Philips Semiconductors make no representation or warranty that such applications will be suitable for the specified use without further testing or modification.

19. Disclaimers

Life support — These products are not designed for use in life support appliances, devices, or systems where malfunction of these products can reasonably be expected to result in personal injury. Philips Semiconductors

21. Contact information

For additional information, please visit: <http://www.semiconductors.philips.com>

For sales office addresses, send an email to: sales.addresses@www.semiconductors.philips.com

customers using or selling these products for use in such applications do so at their own risk and agree to fully indemnify Philips Semiconductors for any damages resulting from such application.

Right to make changes — Philips Semiconductors reserves the right to make changes in the products - including circuits, standard cells, and/or software - described or contained herein in order to improve design and/or performance. When the product is in full production (status 'Production'), relevant changes will be communicated via a Customer Product/Process Change Notification (CPCN). Philips Semiconductors assumes no responsibility or liability for the use of any of these products, conveys no license or title under any patent, copyright, or mask work right to these products, and makes no representations or warranties that these products are free from patent, copyright, or mask work right infringement, unless otherwise specified.

20. Trademarks

STARplug — is a trademark of Koninklijke Philips Electronics N.V.

EZ-HV — is a trademark of Koninklijke Philips Electronics N.V.

22. Contents

1	General description	1
2	Features	1
3	Applications	1
4	Quick reference data	2
5	Ordering information	2
6	Block diagram	3
7	Pinning information	3
7.1	Pinning	3
7.2	Pin description	4
8	Functional description	4
8.1	Start-up and undervoltage lock-out	4
8.2	Oscillator	4
8.3	Duty factor control	5
8.4	Valley switching	5
8.5	Demagnetization	7
8.6	Protections	7
8.6.1	Overcurrent protection	7
8.6.2	Short winding protection	7
8.6.3	Overtemperature protection	7
8.6.4	Overvoltage protection	7
8.7	Characteristics of the complete power-plug ...	7
8.7.1	Input	7
8.7.2	Accuracy	7
8.7.3	Efficiency	8
8.7.4	Ripple	8
9	Limiting values	8
10	Thermal characteristics	9
11	Characteristics	9
12	Application information	11
13	Test information	11
13.1	Quality information	11
14	Package outline	12
15	Soldering	13
15.1	Introduction to soldering through-hole mount packages	13
15.2	Soldering by dipping or by solder wave	13
15.3	Manual soldering	13
15.4	Package related soldering information	13
16	Revision history	14
17	Data sheet status	15
18	Definitions	15
19	Disclaimers	15
20	Trademarks	15
21	Contact information	15

© Koninklijke Philips Electronics N.V. 2004

All rights are reserved. Reproduction in whole or in part is prohibited without the prior written consent of the copyright owner. The information presented in this document does not form part of any quotation or contract, is believed to be accurate and reliable and may be changed without notice. No liability will be accepted by the publisher for any consequence of its use. Publication thereof does not convey nor imply any license under patent- or other industrial or intellectual property rights.

Date of release: 17 March 2004
Document order number: 9397 750 12578

Published in The Netherlands

