



**Features**

- **2A continuous output current**
- **Wide input voltage range: 4.5V to 26V**
- **Wide output voltage range: 0.923V to 23V**
- **Tight  $V_{FB}$  variation: 1.5% (TF6002A), 2.5% (TF6002)**
- **High, >90%, efficiency ( $V_{IN} = 5V, 0.15A < I_L < 2A$ ) enabled by integrated 130 mΩ MOSFET switches**
- **Operates at fixed 340 kHz frequency for small filter size**
- **3 μA (MAX) shut-down supply current**
- **Programmable soft-start, cycle-by-cycle over-current protection and input under-voltage lockout**
- **Industrial temperature range: -40 °C to +85 °C**
- **Drop-in replacement for MP2305, MP1482**

**Applications**

- High-Density Point-of-Load Regulators
- Distributed Power Systems
- Notebook and Netbook Computers
- Power Supplies for FPGAs, DSP Blocks and ASICs
- Set-Top Boxes
- xDSL Modems

**Typical Application**

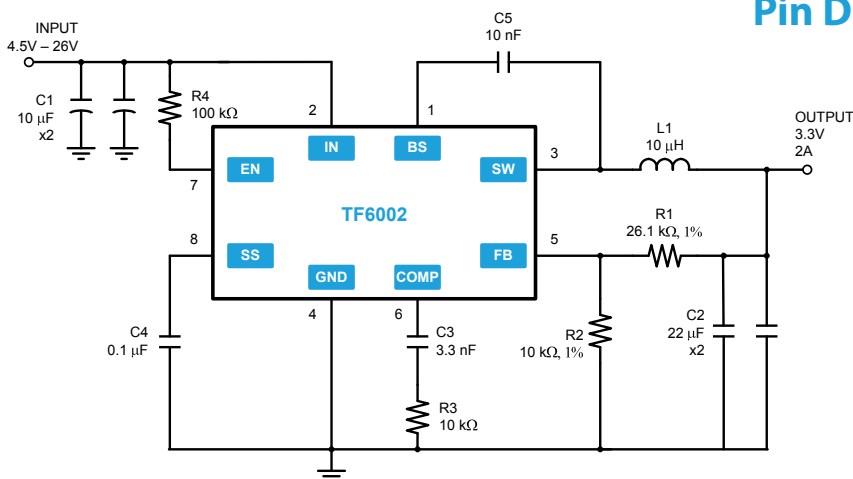

**Description**

The TF6002 and TF6002A are monolithic synchronous buck regulators featuring integrated 130 mΩ MOSFETs that provide continuous 2A output load current. They operate over a wide 4.5V to 26V input voltage range and provide output voltage from 0.923V to 23V at up to 93% efficiency. Their current mode control circuitry provides fast transient response and cycle-by-cycle current limit.

The TF6002 and TF6002A have the  $V_{FB}$  variation of only 2.5% and 1.5%, respectively, providing tight output regulation.

The TF6002 and TF6002A operate at fixed 340 kHz switching frequency. They feature programmable soft-start which prevents inrush current at turn-on. In shut-down mode they draw only 3 μA (MAX).

Both devices are offered in an 8-pin SOIC narrow package and operate over an extended -40 °C to +85 °C temperature range.



**Ordering Information**

PART NUMBER	PACKAGE	PACKING	Year Year Week Week		MARK
			Year	Week	
TF6002-TAS	SOIC-8(N)	Tube,	95		TF YYWW TF6002 Lot ID
TF6002-TAP	SOIC-8(N)	Tape & Reel,	1000		
TF6002-TAQ	SOIC-8(N)	Tape & Reel,	2500		
TF6002A-TAP	SOIC-8(N)	Tape & Reel,	1000		TF YYWW TF6002A Lot ID
TF6002A-TAQ	SOIC-8(N)	Tape & Reel,	2500		

**Pin Diagram**

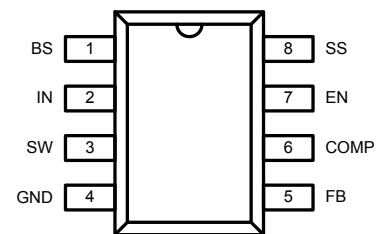

**Top View**

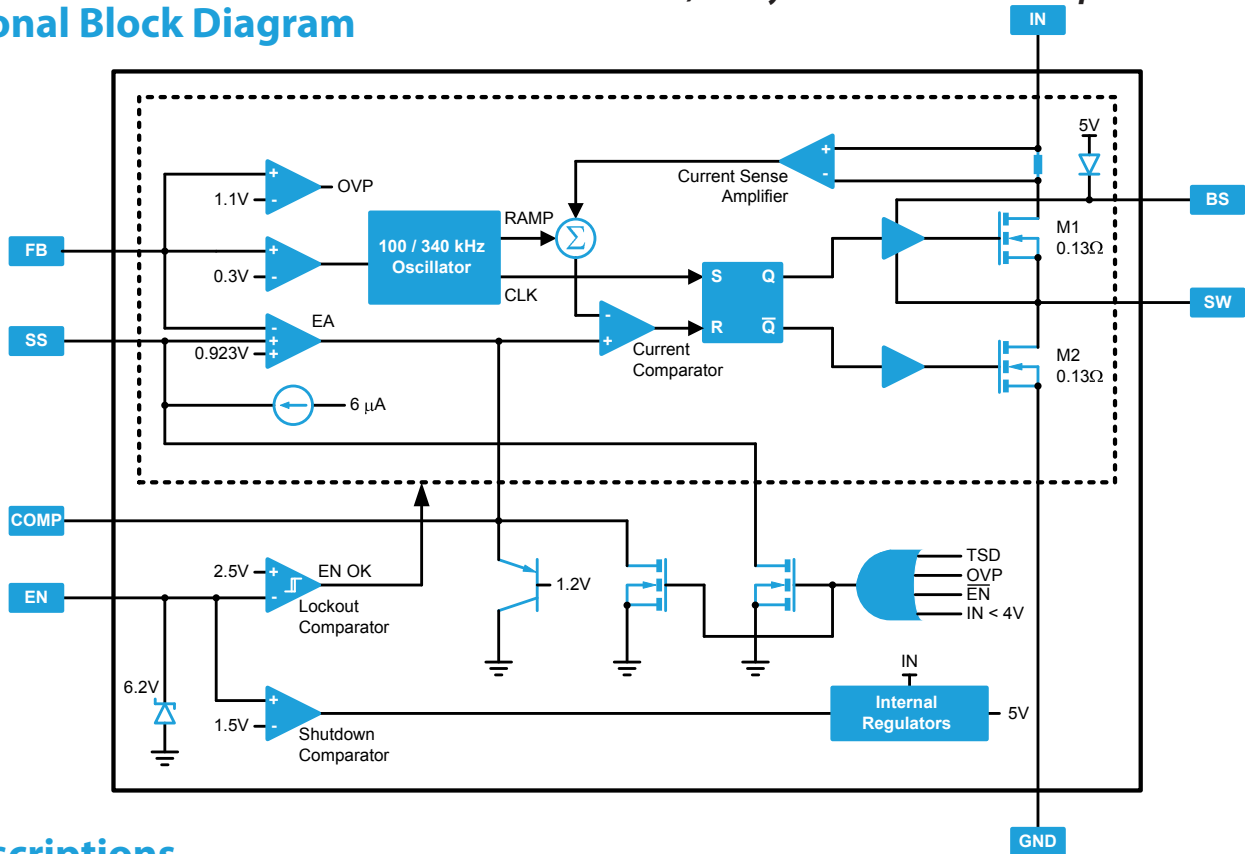
**2A, 26V Synchronous Rectified Step-Down Converter**
**Functional Block Diagram**

**Pin Descriptions**

PIN NAME	PIN NUMBER	PIN DESCRIPTION
BS	1	High-side gate drive boost input pin. The BS pin supplies the drive for the high-side N-Channel MOSFET switch. Connect a 0.01 $\mu\text{F}$ or greater capacitor from SW to BS to power up the high-side switch.
IN	2	Power input pin. The IN pin supplies the power to the IC and the step-down converter switches. Drive the IN pin with a 4.5V to 26V power source. Bypass the IN pin to GND pin with an appropriate large capacitor to minimize noise on the input to the device.
SW	3	Power switching output pin. The SW pin is the switching node that supplies power to the output. Connect a LC filter from SW pin to the output load. Note that a capacitor is needed from SW pin to BS pin to power the high-side switch.
GND	4	Ground pin.
FB	5	Feedback input pin. The FB pin senses the output voltage to regulate that voltage. Drive the FB pin with a resistive voltage divider from the output voltage. The feedback threshold is 0.923V.
COMP	6	Compensation input pin. The COMP pin is used to compensate the regulation control loop. Connect a series RC filter from COMP to GND pin to compensate the regulation loop. In some cases, additional capacitor is needed.
EN	7	Enable input pin. The EN pin is a digital input pin that enables or disables the regulator. Set the EN pin to high to turn the regulator on; set it to low, to turn the regulator off. Use 100 k $\Omega$ pull-up resistor for automatic start-up.
SS	8	Soft-start control input pin. The SS pin controls the soft-start period. Connect a capacitor from the SS pin to the GND pin to set the soft-start period. A 0.1 $\mu\text{F}$ capacitor sets the soft-start period to 15 ms. To disable the soft-start feature, leave the SS pin unconnected.

**2A, 26V Synchronous Rectified Step-Down Converter**
**Absolute Maximum Ratings (NOTE1)**

$V_{IN}$  - Supply voltage .....-0.3V to +28V  
 $V_{SW}$  - Switch voltage .....-1V to  $V_{IN}$   
 $V_{BS}$  - Boost voltage ..... $V_{SW} - 0.3V$  to  $V_{SW} + 6V$   
 All other pins .....-0.3V to +6V

**SOIC-8 Thermal Resistance (NOTE2)**

$\theta_{JC}$  .....45 °C/W  
 $\theta_{JA}$  .....90 °C/W

$T_J$  - Junction operating temperature .....+150 °C  
 $T_L$  - Lead temperature (soldering, 10s) ..... +260 °C  
 $T_{stg}$  - Storage temperature range .....-65 °C to +150 °C

**NOTE1** Stresses beyond those listed under "Absolute Maximum Ratings" may cause permanent damage to the device. These are stress ratings only, and functional operation of the device at these or any other conditions beyond those indicated in the operational sections of the specifications is not implied. Exposure to absolute maximum rating conditions for extended periods may affect device reliability.

**NOTE2** When mounted on a standard JEDEC 2-layer FR-4 board.

**Recommended Operating Conditions**

$V_{IN}$  - Input voltage .....4.5V to +26V  
 $V_{SW}$  - Output voltage .....0.923V to 23V  
 $T_A$  - Operating ambient temperature range.....-40 °C to +85 °C

**Electrical Characteristics**

$T_A = 25\text{ °C}$ ,  $V_{IN} = 12V$ , unless otherwise specified.

Symbol	Parameter	Conditions	MIN	TYP	MAX	Unit	
$I_{sd}$	Shutdown supply current	$V_{EN} = 0V$		1	3	$\mu A$	
$I_{IN}$	Supply current	$V_{EN} = 2V, V_{FB} = 1V$		1.3	1.5	mA	
$V_{FB}$	Feedback voltage	$4.5V < V_{IN} < 26V$ (NOTE3)	TF6002	0.9	0.923	0.946	V
			TF6002A	0.909	0.923	0.937	
$V_{FBth}$	Feedback over-voltage threshold			1.1		V	
$A_{EA}$	Error amplifier voltage gain	(NOTE4)		400		V/V	
$G_{EA}$	Error amplifier transconductance	$\Delta I_C = 10\ \mu A$		800		$\mu A/V$	
$R_{DS(ON)1}$	High-side switch ON resistance	(NOTE4)		130		m $\Omega$	
$R_{DS(ON)2}$	Low-side switch ON resistance	(NOTE4)		130		m $\Omega$	
$I_{DS(off)}$	High-side switch leakage current	$V_{EN} = 0V, V_{SW} = 0V$			10	$\mu A$	
$I_{DS(lim)1}$	Upper switch current limit	Minimum duty cycle	2.4	3.4		A	
$I_{DS(lim)2}$	Lower switch current limit	From drain to source		1.1		A	
$G_{CS}$	COMP to current sense transconductance			3.5		A/V	

## Electrical Characteristics

Symbol	Parameter	Conditions	MIN	TYP	MAX	Unit
$f_{osc}$	Oscillation frequency			340		kHz
$f_{osc(sc)}$	Short-circuit oscillation frequency	$V_{FB} = 0V$		100		kHz
$D_{MAX}$	Maximum duty cycle	$V_{FB} = 1V$		90		%
$t_{ONmin}$	Minimum ON time	<b>(NOTE4)</b>		220		ns
$V_{EN(sd\_th)}$	Enable shutdown threshold voltage	$V_{EN}$ rising	1.1	1.5	2.0	V
$V_{EN(sd\_th\_hyst)}$	Enable shutdown threshold voltage hysteresis			210		mV
$V_{EN(lo\_th)}$	Enable lockout threshold voltage		2.2	2.5	2.7	V
$V_{EN(lo\_th\_hyst)}$	Enable lockout threshold voltage hysteresis			210		mV
$V_{IN(lo\_th)}$	Input under-voltage lockout threshold voltage	$V_{IN}$ rising	3.8	4.0	4.4	V
$V_{IN(lo\_th\_hyst)}$	Input under-voltage lockout threshold voltage hysteresis			210		mV
$I_{SS}$	Soft-start current	$V_{SS} = 0V$		6		$\mu A$
$t_{SS}$	Soft-start period	$C_{SS} = 0.1 \mu F$		15		ms
$T_{sd}$	Thermal shutdown	<b>(NOTE4)</b>		160		$^{\circ}C$

**NOTE3** TF6002A: Typical performance 0-85 $^{\circ}C = 0.923V \pm 1.95\%$ , not tested over temperature during regular production

**NOTE4** Not subject to production test - verified by design/characterization

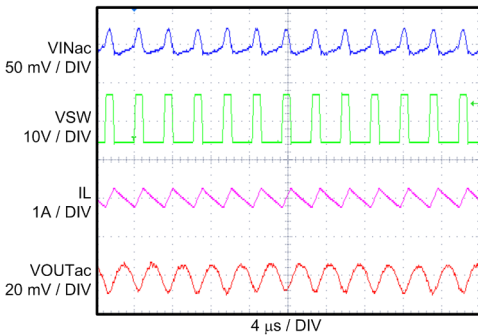
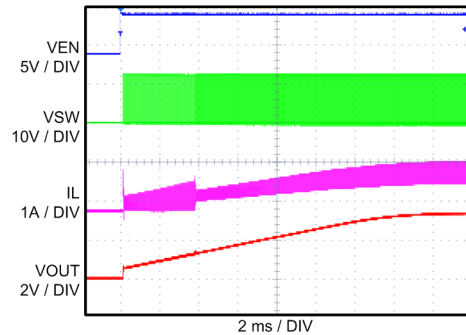
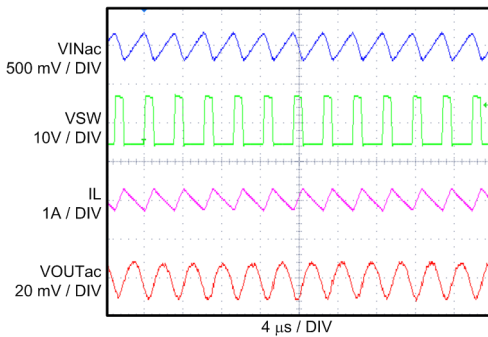
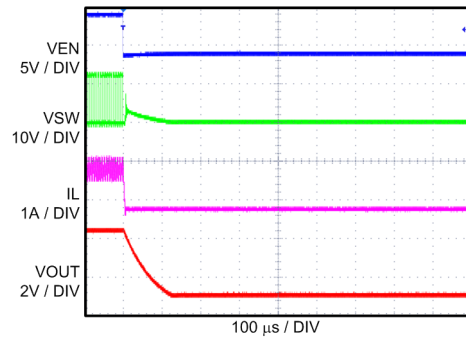
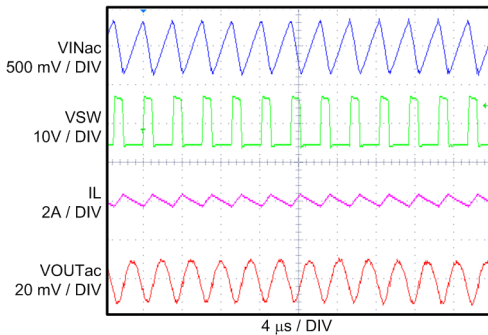
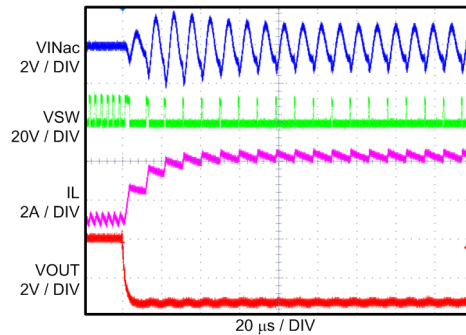
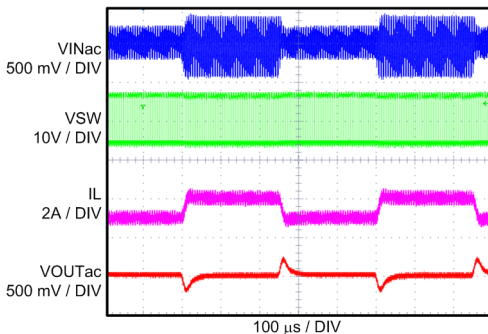
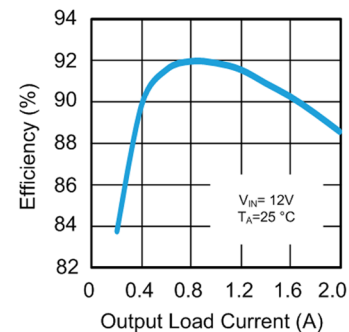
**2A, 26V Synchronous Rectified Step-Down Converter**
**Typical Performance**
 $V_{IN} = 12V, V_{OUT} = 3.3V, L = 15 \mu H, C_{IN} = 10 \mu F, C_{OUT} = 22 \mu F, T_A = 25^\circ C$ , unless otherwise specified.

**Figure 1.** No-Load Steady State Operation

**Figure 5.** 1A-Resistive-Load Startup Via Enable Operation

**Figure 2.** 1A-Load Steady State Operation

**Figure 6.** 1A-Resistive-Load Shutdown Via Enable Operation

**Figure 3.** 2A-Load Steady State Operation

**Figure 7.** Short Circuit Entry Operation

**Figure 4.** Transient Load Response

**Figure 8.** Efficiency as a Function of Load

**2A, 26V Synchronous Rectified Step-Down Converter**

## Application Information

The TF6002 is a monolithic synchronous buck regulator featuring integrated 130 mΩ Power MOSFETs that can provide up to 2A of load current. It regulates input voltages from 4.5V to 26V down to an output voltage as low as 0.923V while providing soft-start, cycle-by-cycle over-current, under-voltage lockout and over-temperature protection.

This section of the datasheet describes typical application circuits, provides recommendations on component selection, and discusses thermal and layout design considerations.

### TYPICAL APPLICATIONS

The TF6002 uses a fixed frequency, current-mode step-down regulator architecture to deliver constant voltage to the load. Figure 9 shows a typical application circuit.

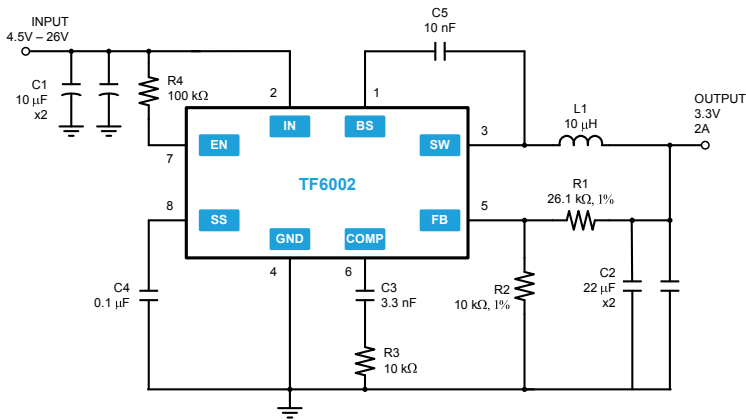

**Figure 9.** Typical Application Circuit

The circuit of Figure 9 takes an input voltage between 4.5V and 26V and regulates it down to 3.3V while bringing 2A of load current.

### SETTING THE OUTPUT VOLTAGE

Based on the circuit of Figure 9, the output voltage depends on the feedback voltage,  $V_{FB}$ , and the resistor divider network consisting of R1 and R2, as expressed with the following equation:

$$V_{OUT} = V_{FB} \cdot \frac{R_1 + R_2}{R_2}$$

The R2 resistor value may be as high as 100 kΩ, however 10 kΩ resistor value is typically recommended. Given this and the typical  $V_{FB}$  of 0.923V, the R1 resistor may easily be calculated for a desired output voltage. Table 1 exemplifies several standard resistor values needed to achieve desired output voltage. If standard resistor values are not available a parallel combination of two standard resistors may also be used.

$V_{OUT}$ [V]	R1 [kΩ]	R2 [kΩ]
1.2	3.0	10
1.8	9.53	10
2.5	16.9	10
3.3	26.1	10
5	44.2	10
12	121	10

**Table 1.** Examples of Standard Value Resistors for a Desired Output Voltage

**2A, 26V Synchronous Rectified Step-Down Converter**

## Component Selection

**Inductor:** High frequency operation of the TF6002 allows the use of small surface mount inductors. The minimum inductance value is inversely proportional to the operating frequency and is bounded by the following limits:

$$L = \frac{V_{OUT} \cdot (V_{IN} - V_{OUT})}{f_s \cdot I_{L(MAX)ripple} \cdot V_{IN}} [H]$$

where

- $f_s$  = Operating frequency [Hz]
- $I_{L(MAX)ripple}$  = Allowable maximum inductor current ripple [A]
- $V_{IN}$  = Input voltage [V]
- $V_{OUT}$  = Output voltage [V]

The inductor current ripple is typically set to 20% to 40% of the maximum load current. Given this, the operating frequency and the input and output voltages for the TF6002 regulator circuits, it is easy to calculate the optimal inductor value which typically ranges between 10 and 47  $\mu$ H. Note that a larger value inductor will result in less ripple current and ultimately in lower output ripple voltage. However, the larger value inductor will have a larger physical size, higher series resistance, and lower saturation current.

Choose an inductor that will not saturate under the maximum inductor peak current. The peak inductor current is given in the following equation:

$$I_{L(peak)} = I_{LOAD} + \frac{V_{OUT} \cdot (V_{IN} - V_{OUT})}{2 \cdot f_s \cdot L \cdot V_{IN}} [A]$$

For high efficiency, it is recommended to select an inductor with a high frequency core material (e.g. ferrite) to minimize core losses. Low ESR (equivalent series resistance) is another preferred inductor characteristic when designing for low losses. The inductor must handle the peak inductor current at full load without saturating. Note that the peak inductor current must be below the maximum switch current limit. Chip inductors typically do not have enough core to support the peak inductor currents above 1A and are not suitable for the TF6002 applications. Lastly, select a toroid, pot core or shielded bobbin inductor for low radiated noise. Table 2 provides a list of recommended inductor series.

Inductor Series	Supplier	Website
SRU8043	Bourns Inc.	www.bourns.com
MSS7341	Coilcraft	www.coilcraft.com
LQH88P	Murata	www.murata.com
DR1040	Coiltronics	www.coiltronics.com
CDRH8D43	Sumida	www.sumida.com

**Table 2.** List of Recommended Inductor Series

**Optional Schottky Diode:** During the transition between the high-side switch and the low side switch, the body diode of the low-side switch (N-channel power MOSFET) conducts the inductor current. Forward voltage of this body diode is relatively high, therefore, an optional Schottky diode may be paralleled between SW and GND pins. The Schottky diode which features low forward voltage and fast recovery time will result in improved peak efficiency of the buck regulator circuits. Table 3 provides a list of recommended diode series.

Diode Series	Supplier	Website
MBR130	MCC	www.mcc.com
SBR	Diodes Inc.	www.diodes.com
B130	Vishay	www.vishay.com

**Table 3.** List of Recommended Schottky Diode Series

The connection of the optional Schottky diode (D1) is shown in Figure 9.



**2A, 26V Synchronous Rectified Step-Down Converter**
**Component Selection (continued)**

**Input Capacitor:** The input current to the buck regulator is discontinuous, therefore, a capacitor is required to supply AC current to the regulator while maintaining the DC input voltage.

The input capacitor of Figure 9 (C1) absorbs the input switching current, therefore, it requires adequate ripple current rating. The RMS current in the input capacitor can be estimated using the following equation:

$$I_{C1} = I_{LOAD} \cdot \sqrt{\frac{V_{OUT}}{V_{IN}} \cdot \left[ 1 - \frac{V_{OUT}}{V_{IN}} \right]}$$

The worst case condition occurs when  $V_{IN}$  is twice the value of  $V_{OUT}$ . In this case, the  $I_{C1}$  is equal to the half of the load current. As a rule of thumb, select the input capacitor with the RMS current rating greater than the half of the maximum load current.

The input capacitor reduces peak currents drawn from the input source and reduces input switching noise. The input voltage ripple caused by the input capacitor can be estimated using the following equation:

$$\Delta V_{IN} = \frac{I_{LOAD}}{C_1 \cdot f_s} \cdot \frac{V_{OUT}}{V_{IN}} \cdot \left[ 1 - \frac{V_{OUT}}{V_{IN}} \right]$$

The input capacitor values in the range between 10 and 47  $\mu$ F are sufficient in most cases. Low ESR capacitors are recommended for a low loss operation. Ceramic capacitors with X5R or X7R dielectrics are preferred, however, tantalum and electrolytic capacitors are acceptable as well. When using electrolytic or tantalum capacitors, a small (e.g. 0.1  $\mu$ F), ceramic capacitors should also be used and placed as close to the IN pin as possible. Table 4 provides a list of recommended capacitor series.

**Output Capacitor:** The value of the output capacitor of Figure 9 (C2) has an effect on the output voltage ripple as expressed in the following equation:

$$\Delta V_{OUT} = \frac{V_{OUT}}{f_s \cdot L_1} \cdot \left[ 1 - \frac{V_{OUT}}{V_{IN}} \right] \cdot \left[ ESR_{C2} + \frac{1}{8 \cdot f_s \cdot C_2} \right]$$

where

- $f_s$  = Operating frequency [Hz]
- $ESR_{C2}$  = Equivalent series resistance of C2
- $V_{IN}$  = Input voltage [V]
- $V_{OUT}$  = Output voltage [V]

The output capacitor, C2, can be ceramic, tantalum or electrolytic type. When using ceramic capacitors, the impedance at the switching frequency is dominated by the capacitance, therefore, the above equation may be simplified as the following:

$$\Delta V_{OUT} = \frac{V_{OUT}}{8 \cdot f_s \cdot L_1 \cdot C_2} \cdot \left[ 1 - \frac{V_{OUT}}{V_{IN}} \right]$$

When using tantalum or electrolytic capacitors, the ESR dominates the impedance at the switching frequency, therefore, the original output voltage ripple equation can be re-written as the following expression:

$$\Delta V_{OUT} = \frac{V_{OUT}}{f_s \cdot L_1} \cdot \left[ 1 - \frac{V_{OUT}}{V_{IN}} \right] \cdot ESR_{C2}$$

The output capacitor values in the range between 10 and 47  $\mu$ F provide low output voltage ripple in most cases. Table 4 provides a list of recommended capacitor series.

Capacitor Series	Supplier	Website
0201-2225 Ceramic, TPS, TPM Tantalum	AVX	www.avx.com
MK107, MK212, MK316 Ceramic	Taiyo Yuden	www.t-yuden.com
POSCAP Electrolytic	Sanyo	edc.sanyo.com

**Table 4.** List of Recommended Capacitor Series



**2A, 26V Synchronous Rectified Step-Down Converter**
**Component Selection (continued)**

**Compensation Components:** TF6002 employs current mode control for easy compensation and fast transient response. System stability and transient response are controlled via COMP pin. COMP pin is the output of the internal transconductance error amplifier. A series RC network (C3 and R3 of Figure 9) sets a pole-zero combination and controls the characteristics of the control system. The DC gain of the voltage feedback loop is given by the following equation:

$$A_{VDC} = R_{LOAD} \cdot G_{CS} \cdot A_{VEA} \cdot \frac{V_{FB}}{V_{OUT}}$$

where

- $G_{CS}$  = Current sense transconductance
- $A_{VEA}$  = Error amplifier voltage gain

The system has two poles of importance. One is due to the compensation capacitor (C3 of Figure 9) and the output resistor of the error amplifier. The other one is due to output capacitor (C2 of Figure 9) and the load resistor. These poles are located at:

$$f_{P1} = \frac{G_{EA}}{2\pi \cdot C_3 \cdot A_{VEA}}$$

$$f_{P2} = \frac{1}{2\pi \cdot C_2 \cdot R_{LOAD}}$$

where

- $G_{EA}$  = Error amplifier transconductance

The system has one zero of importance, due to the compensation capacitor (C3) and the compensation resistor (R3). The zero is located at:

$$f_{Z1} = \frac{1}{2\pi \cdot C_3 \cdot R_3}$$

The system may also have another zero of importance due to high output capacitance and ESR of C2 (output capacitor of Figure 9). The zero is located at:

$$f_{Z2} = \frac{1}{2\pi \cdot C_2 \cdot ESR_{C2}}$$

The C6 may be added to compensate for the ESR of C2. The C6 together with R3 creates another pole which is located at:

$$f_{P3} = \frac{1}{2\pi \cdot C_6 \cdot R_3}$$

The aim of the compensation design is to shape the converter transfer function to get a desired loop gain. The system crossover frequency where the feedback loop has the unity gain is important. Lower crossover frequencies result in slower line and load transient responses, while higher crossover frequencies could cause system to be unstable. As a rule of thumb, the crossover frequency ( $f_c$ ) below one tenth of the switching frequency is recommended. This is expressed using in the following inequality:

$$f_c < \frac{f_s}{10}$$

The following steps may be used for optimizing the compensation components:

1. Select the compensation resistor, R3 to set the desired crossover frequency. The R3 resistor value can be determined using the following equation:

$$R_3 = \frac{2\pi \cdot C_2 \cdot f_c \cdot V_{OUT}}{G_{EA} \cdot G_{CS} \cdot V_{FB}}$$

2. Select the compensation capacitor C3 to achieve the desired phase margin. For applications with typical inductor values, setting the compensation zero,  $f_{Z1}$ , below one quarter of the crossover frequency provides sufficient phase margin. The C3 capacitor value can be determined using the following inequality:

$$C_3 > \frac{4}{2\pi \cdot R_3 \cdot f_c}$$

3. Determine if the second compensation capacitor, C6, is needed. It is needed if the ESR zero ( $f_{Z2}$ ) of the output capacitor (C2) is located at less than half of the switching frequency as expressed in the following inequality:

**2A, 26V Synchronous Rectified Step-Down Converter**
**Component Selection (continued)**

$$\frac{f_s}{2} > \frac{1}{2\pi \cdot C_2 \cdot ESR_{C_2}}$$

If the above inequality is valid, add the second compensation capacitor, C6, to set the third pole,  $f_{p3}$ , at the location of the ESR zero,  $f_{z2}$ . The C6 capacitor value can be determined using the following equation:

$$C_6 = \frac{C_2 \cdot ESR_{C_2}}{R_3}$$

**External Bootstrap Diode:** To improve the efficiency of the regulator, an external Bootstrap diode, D2, can be connected (Figure 10).

This is valid only if there is a 5V available in the system. Either a separate voltage or the regulator is set to generate 5V output voltage.

It helps efficiency when running with high dutycycle ( $V_{out}/V_{in}$ ) over 65%. Bootstrap diode can be a low cost type like 1N4148 or BAT54.

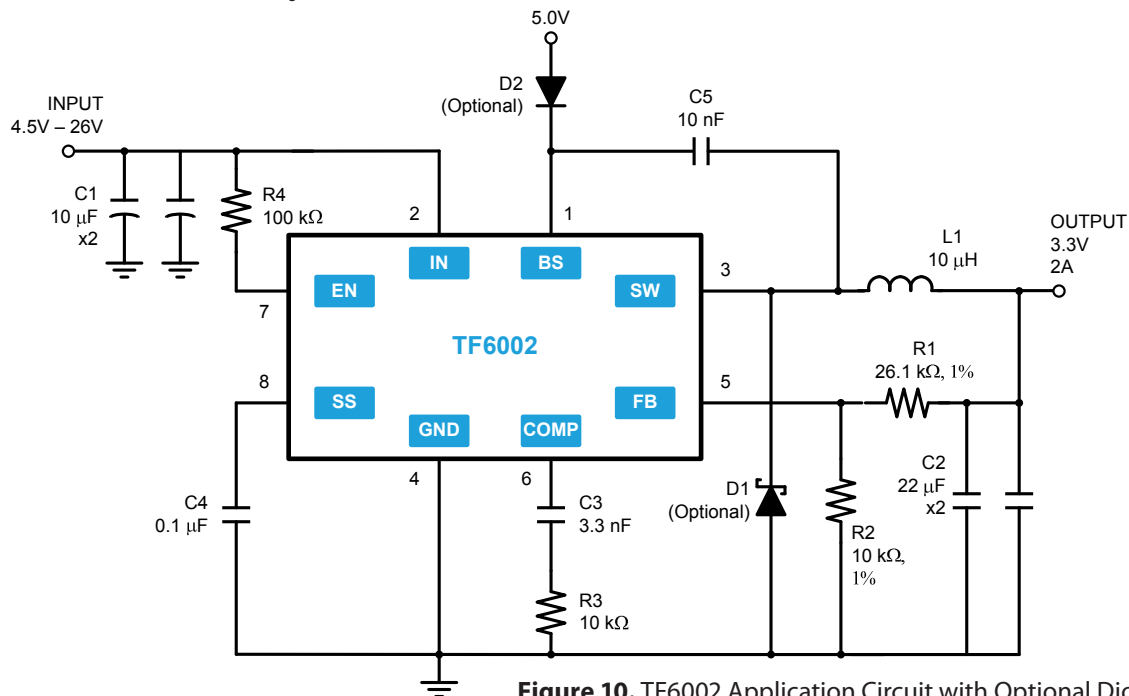

**Figure 10.** TF6002 Application Circuit with Optional Diodes

**PCB Layout Considerations**

**When using DC-DC switching power converters, a carefully designed PCB layout is mandatory.**

1. Because of the fast switching slopes, the wire areas and lengths between switching pins and connected components have to be small, to keep noise and electromagnetic interference as low as possible. Therefore place the inductor preferably close to the switch pin.
2. Sensitive high ohmic nodes may not be placed close to high current and/or switching paths. For example keep the feedback net away from the switching node. Also keep it short and as close to the chip as possible. If it's feasible, use ground paths to shield these sensitive lines.
3. Place the input capacitor as close to the chip as possible. The output capacitor should be placed close to the inductor and optional catch diode. Make sure that input and output capacitor are well connected at the ground side.
4. To keep the switching ripple on the input and output voltage low, use low ESR ceramic bypass capacitors.
5. Keep in mind the voltage- and temperature dependency of capacitor types. Therefore X5R and X7R capacitors are highly recommended as input and output capacitors as well as for the compensation.
6. Take care of possible ground shift! To avoid unwanted ground shift that may have disturbing effects on the regulation loop, a big ground plane is recommended. For optimal performance, use a PCB board with at least two metal layers, so that one of the layers can be used as a ground plane.
7. Consider high current paths. The connection between input board connector, input cap and input pin as well as the connection between output board connector, output cap and inductor and the connection between switch pin and inductor have to be wide enough to avoid unwanted voltage drop caused by parasitic resistance.

**Package Dimensions (SOIC-8(N))**

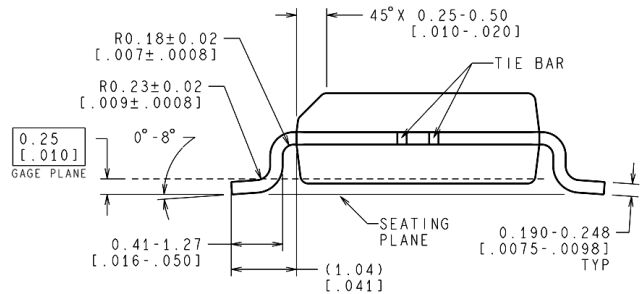
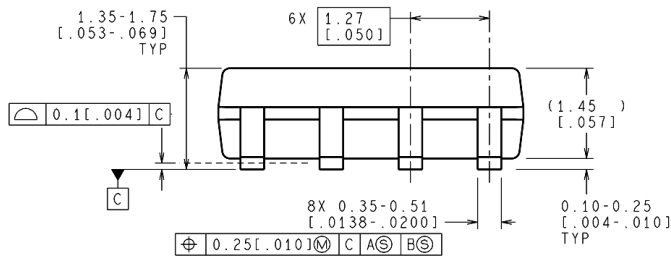
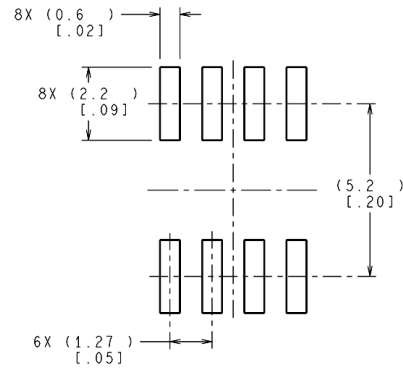
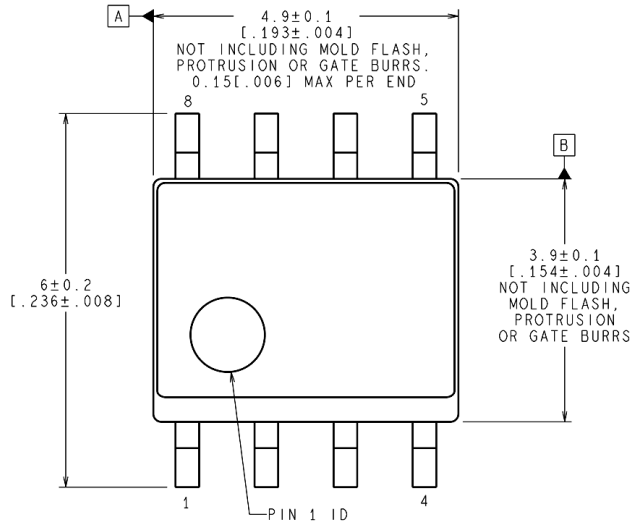

NOTES: UNLESS OTHERWISE SPECIFIED

1. REFERENCE JEDEC REGISTRATION MS-012, VARIATION AA.

**CONTROLLING DIMENSION IS MILLIMETER  
VALUES IN [ ] ARE INCHES  
DIMENSIONS IN ( ) FOR REFERENCE ONLY**

## Notes

### Important Notice

Telefunken Semiconductors PRODUCTS ARE NEITHER DESIGNED NOR INTENDED FOR USE IN MILITARY AND/OR AEROSPACE, AUTOMOTIVE OR MEDICAL DEVICES OR SYSTEMS UNLESS THE SPECIFIC Telefunken Semiconductors PRODUCTS ARE SPECIFICALLY DESIGNATED BY Telefunken Semiconductors FOR SUCH USE. BUYERS ACKNOWLEDGE AND AGREE THAT ANY SUCH USE OF Telefunken Semiconductors PRODUCTS WHICH Telefunken Semiconductors HAS NOT DESIGNATED FOR USE IN MILITARY AND/OR AEROSPACE, AUTOMOTIVE OR MEDICAL DEVICES OR SYSTEMS IS SOLELY AT THE BUYER'S RISK.

Telefunken Semiconductors assumes no liability for application assistance or customer product design. Customers are responsible for their products and applications using Telefunken Semiconductors products.

Resale of Telefunken Semiconductors products or services with statements different from or beyond the parameters stated by Telefunken Semiconductors for that product or service voids all express and any implied warranties for the associated Telefunken Semiconductors product or service. Telefunken Semiconductors is not responsible or liable for any such statements.

©2012 Telefunken Semiconductors. All rights reserved. Information and data in this document are owned by Telefunken Semiconductors and may not be edited, reproduced, or redistributed in any way without written consent from Telefunken Semiconductors.

For additional information please contact [support@telefunkensemi.com](mailto:support@telefunkensemi.com) or visit [www.telefunkensemiconductors.com](http://www.telefunkensemiconductors.com)