

TF SERIES

TORQUE FLANGE SENSORS

FEATURES

- Complete torque measuring system including: measuring flange with signal amplifier, HF transmitter, conditioner and 4m coaxial cable
- Contactless signal transmission: via telemetry
- Torque range: 20 N·m to 150,000 N·m (higher on demand)
- High accuracy: 0.1% to 0.2% (0.05% option)
- Overload capacity: up to 200% (limit of adhesion)
- Measuring range: 200%
- Breaking torque: 400%
- Compact, easy-to-mount design
- High torsional stiffness
- Bearingless: maintenance and wear-free
- Excellent noise immunity and shock resistance
- Protection class: IP 42 (IP 54 optional)
- Integrated speed sensor and conditioner for rotational speed measurement (optional)
- High temperature capability: up to 125 °C (optional)



Fig.1 : TF 213 Torque Flange sensor with signal amplifier

DESCRIPTION

With its compact, bearingless, maintenance-free design, the TF Torque Flange Sensor from Magtrol brings many appealing advantages to torque measurement applications. The TF's high torsional rigidity supports direct mounting on the machine shaft or flange, avoiding the use of couplings on one side. This allows easy integration into a test system, shortens the overall length of the test bench and reduces costs.

Based on strain-gauge technology, the TF Sensor's precise telemetry system enables highly accurate signal transmission. A signal amplifier mounted in the measuring flange amplifies the measuring signal, modulates it to high frequency and transmits it inductively (via the HF transmitter) to the conditioner. In the conditioner, the digitized torque signal is transformed into an

analog output signal of ± 5 VDC. Rotational speed can be measured and converted to a TTL output signal with the optional speed sensor.

The contactless design of the Torque Flange Sensor permits a gap of up to 5 mm (typically 2 or 3 mm) between the rotor antenna and HF transmitter, which makes the signal acquisition insensitive to any axial or radial misalignment. Another advantage of this torque measurement system is its insusceptibility to signal interference since the antenna does not need to be looped around the measuring flange. Additionally, a protective cover can be mounted close to the TF Sensor with no effect on the signal.

ASSEMBLY



Fig.2 : 1) HF Transmitter 2) Measuring flange with signal amplifier
3) 4 meter coaxial cable 4) Torque conditioner

APPLICATIONS

TF Torque Flange Sensors measure both static and dynamic torque on stationary and rotating shafts. They are used in general combustion engines, electric motor and gearbox test benches; and can also be mounted inline for active torque monitoring of transmissions, powertrains, wind generators, gas turbines, boat engines, etc.

SYSTEM CONFIGURATION

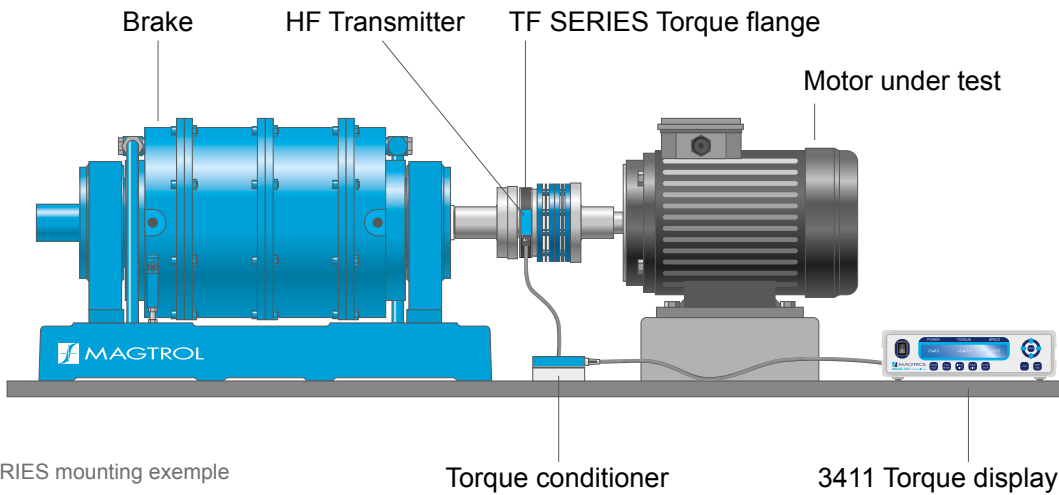

Fig.3 : TF SERIES mounting exemple

ELECTRICAL CONFIGURATION

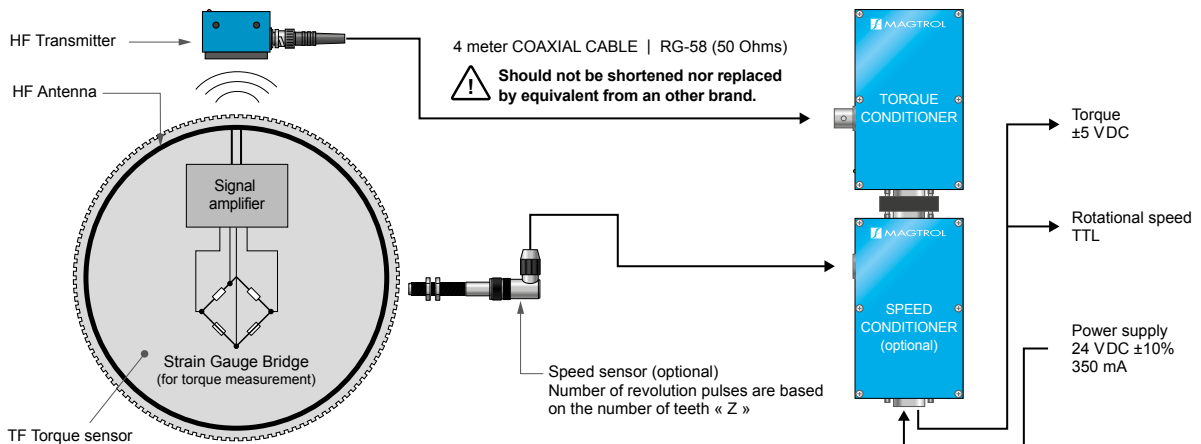

Fig.4 : TF SERIES electrical configuration schematic

TECHNICAL FEATURES

MECHANICAL CHARACTERISTICS

MODEL ^{a)}	RATED TORQUE	OVERLOAD CAPACITY	ACCURACY CLASS	MAXIMUM SPEED	NUMBER OF TEETH ^{c)}	TORSIONAL STIFFNESS	DEFORMATION ANGLE	SENSOR WEIGHT ^{d)}	MOMENT OF INERTIA	
	N·M	% OF RT		RPM	Z	N·M / RAD	°	KG	KG·M ²	LB·FT·S ²
TF 309 TFHS 309	20	200 %	0.1 %	17,000 20,000	52	5.04 x 10 ⁴	0.023	1.4	2.213 x 10 ⁻³	1.633 x 10 ⁻³
TF 310 TFHS 310	50	200 %	0.1 %	17,000 20,000	52	7.20 x 10 ⁴	0.04	1.5	2.236 x 10 ⁻³	1.650 x 10 ⁻³
TF 311 TFHS 311	100	200 %	0.1 %	17,000 20,000	52	8.57 x 10 ⁴	0.067	1.5	2.238 x 10 ⁻³	1.651 x 10 ⁻³
TF 312 TFHS 312	200	200 %	0.1 %	17,000 20,000	52	1.06 x 10 ⁵	0.108	1.5	2.254 x 10 ⁻³	1.663 x 10 ⁻³
TF 213	500	200 %	0.1 % ^{b)}	13,000	91	7.16 x 10 ⁵	0.04	3.3	7.803 x 10 ⁻³	5.758 x 10 ⁻³
TF 214	1,000	200 %	0.1 % ^{b)}	13,000	91	9.55 x 10 ⁵	0.06	3.3	7.818 x 10 ⁻³	5.769 x 10 ⁻³
TF 215	2,000	200 %	0.1 % ^{b)}	10,000	113	2.86 x 10 ⁶	0.04	5.2	1.868 x 10 ⁻²	1.378 x 10 ⁻²
TF 216	5,000	200 %	0.1 %	8,000	133	7.16 x 10 ⁶	0.04	9.3	4.747 x 10 ⁻²	3.505 x 10 ⁻²
TF 217	10,000	150 % ^{e)}	0.1 %	8,000	133	1.25 x 10 ⁷	0.046	9.3	4.706 x 10 ⁻²	3.472 x 10 ⁻²
TF 318	20,000	200 %	0.1 - 0.2 %	3,500	200	4.40 x 10 ⁷	0.026	56.0	1.343	9.905 x 10 ⁻¹
TF 319	50,000	180 % ^{e)}	0.1 - 0.2 %	3,500	200	7.47 x 10 ⁷	0.038	59.0	1.379	1.017
TF 320	100,000	180 % ^{e)}	0.1 - 0.2 %	3,500	200	10.47 x 10 ⁷	0.055	63.5	1.397	1.03

Maximum Dynamic Torque without Damage (Overload Limit)

400 % of Rated Torque

ENVIRONMENT

Rated Temperature Range	+10 °C to +85 °C
Storage Temperature Range	-25 °C to +85 °C
Extended Temperature Range (optional)	-30 °C to +125 °C
Temperature influence on zero	0.01 % / °C
Protection class	IP 42 (optional IP 54)

ELECTRICAL CHARACTERISTICS

Power Supply	24 VDC ±10%, max 350 mA TF 318, TF 319 & TF 320: 100-240 V AC
Torque Output Signal (rated / max.)	±5 V DC / ±10 V DC
Filter Bandwidth	0 to 1 kHz (-3dB) / (optional 5 kHz)

SPEED MEASUREMENT (OPTION)

Number of Teeth	Depending on TF size; refer to number of teeth
Speed Pick-Up Transducer	Magneto-resistive
Minimum Speed Detection	< 1 rpm
Speed Output	TTL (pulses per revolution corresponds to number of teeth)

- a) Torque up to 150 kN·m or higher, and high speed versions are available on request
- b) Linearity- hysteresis error 0.05 % is available on request
- c) Inductive speed detection is available on request
- d) Add 0.8-2.8 kg to weight (depending on configuration), for electronic devices attached to the sensor (HF transmitter, receiver, speed conditioner,...)
- e) Dynamic torque peak values are due to force transmission limit of mounting screws.

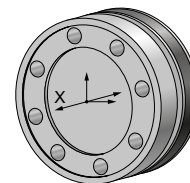
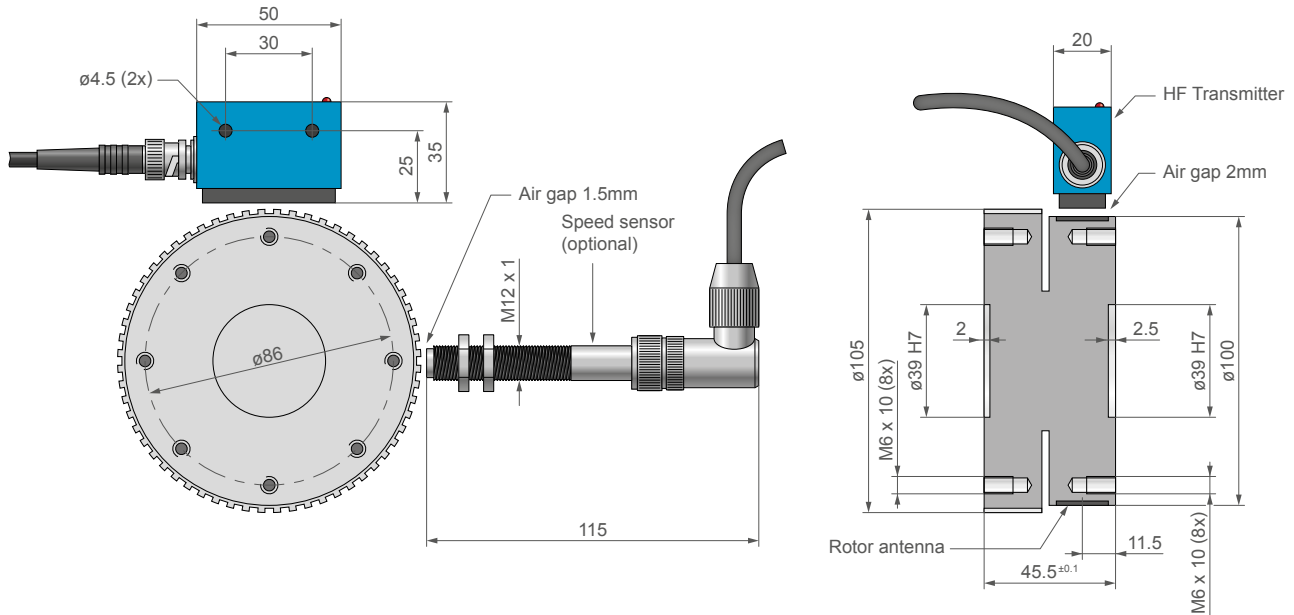
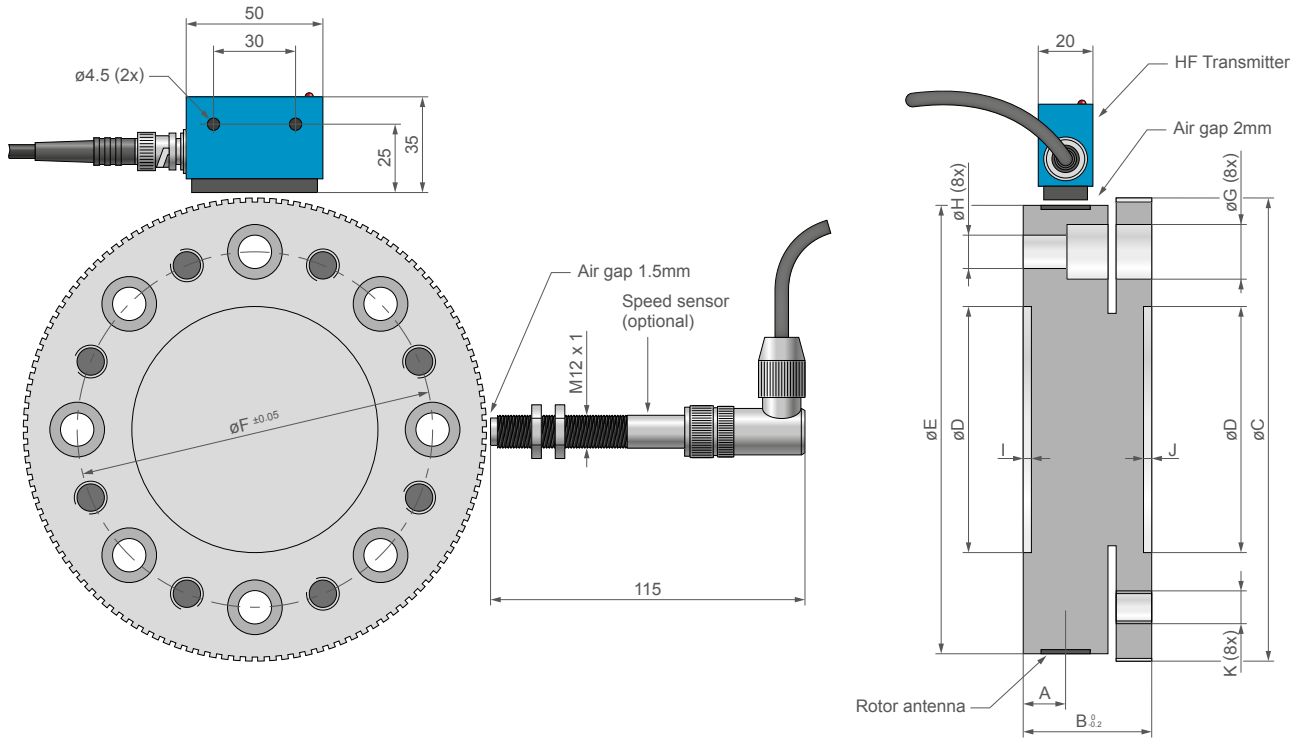

Fig.5 : Moment of inertia (X axis)

DIMENSIONS TF & TFHS 309 - 312



DIMENSIONS TF 213 - 217



MODEL	A	B _{±0.2}	øC	øD H7	øE	øF ±0.05	8x øG	8x øH	I	J	8x K
TF 213	11.5 mm	46 mm	136.5 mm	75 mm	132 mm	101.5 mm	18 mm	10.1 mm	3 mm	3 mm	M10
TF 214	11.5 mm	46 mm	136.5 mm	75 mm	132 mm	101.5 mm	18 mm	10.1 mm	3 mm	3 mm	M10
TF 215	15.5 mm	47 mm	169.5 mm	90 mm	164 mm	130.0 mm	20 mm	12.2 mm	3 mm	3 mm	M12
TF 216	27.0 mm	55 mm	199.5 mm	110 mm	194 mm	155.5 mm	23 mm	15.0 mm	11 mm	3 mm	M14
TF 217	27.0 mm	56.5 mm	199.5 mm	110 mm	194 mm	155.5 mm	26 mm	17.0 mm	11 mm	3 mm	M16

NOTES: 3D .STEP files of most of our products are available as free downloads from our website : www.magtrol.com. Other files are available on request.

DIMENSIONS TF 318 - 319

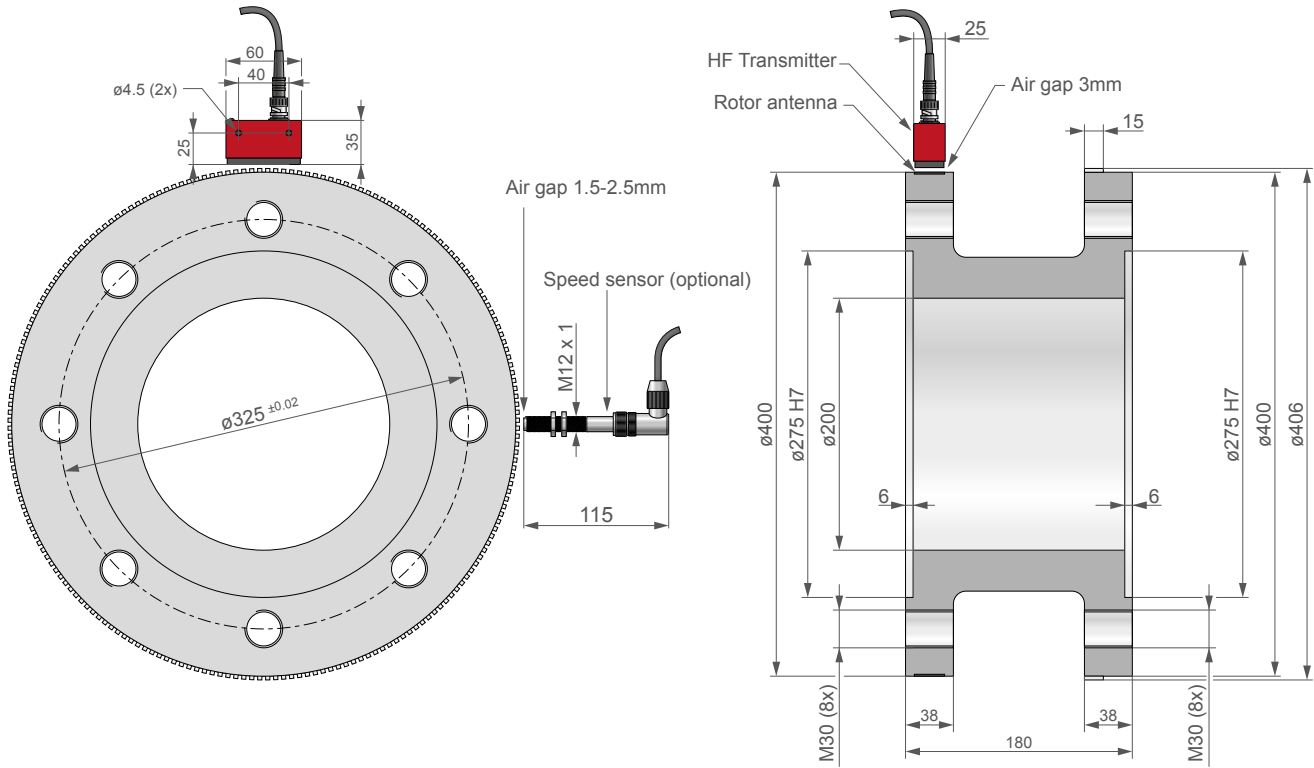

DIMENSIONS TF 320

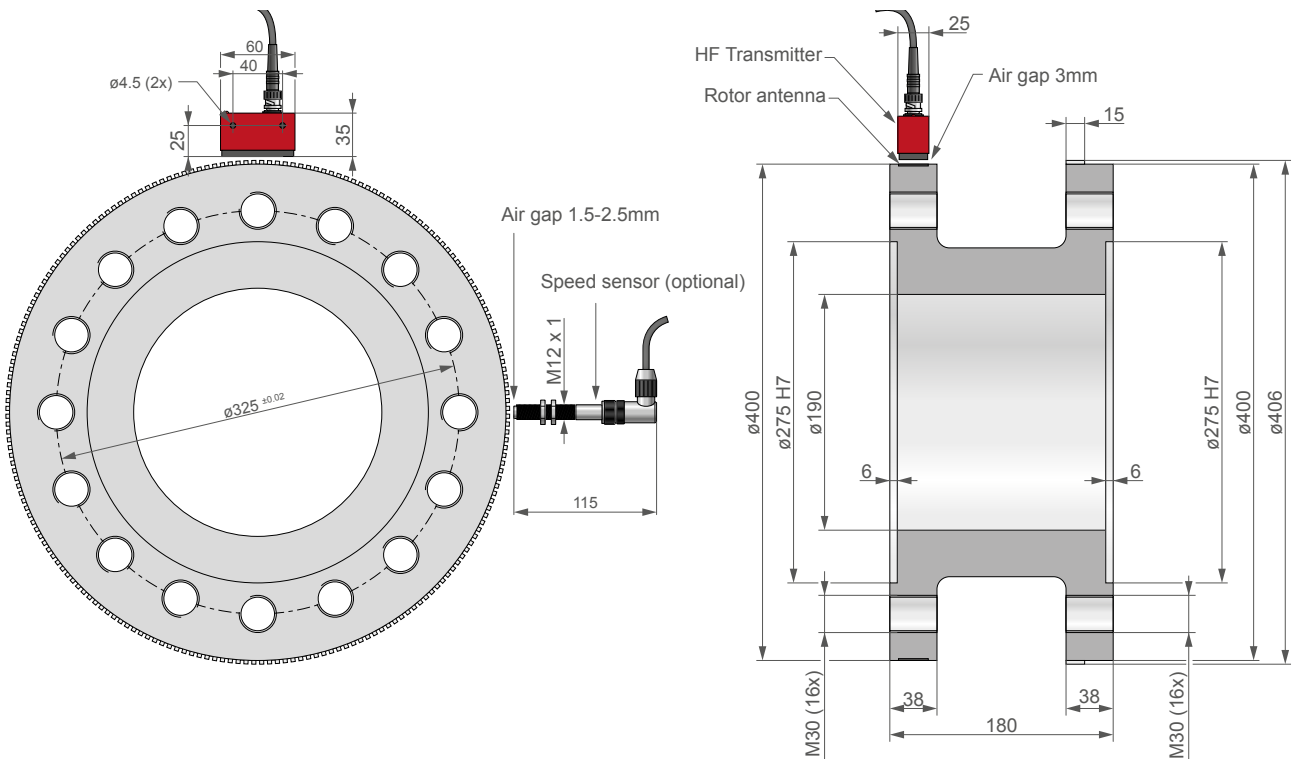

NOTES: 3D .STEP files of most of our products are available as free downloads from our website : www.magtrol.com. Other files are available on request.

STANDARD SPEED SENSOR

The standard speed sensor is delivered with TF Torque Flange Sensors when the speed measurement option is ordered.

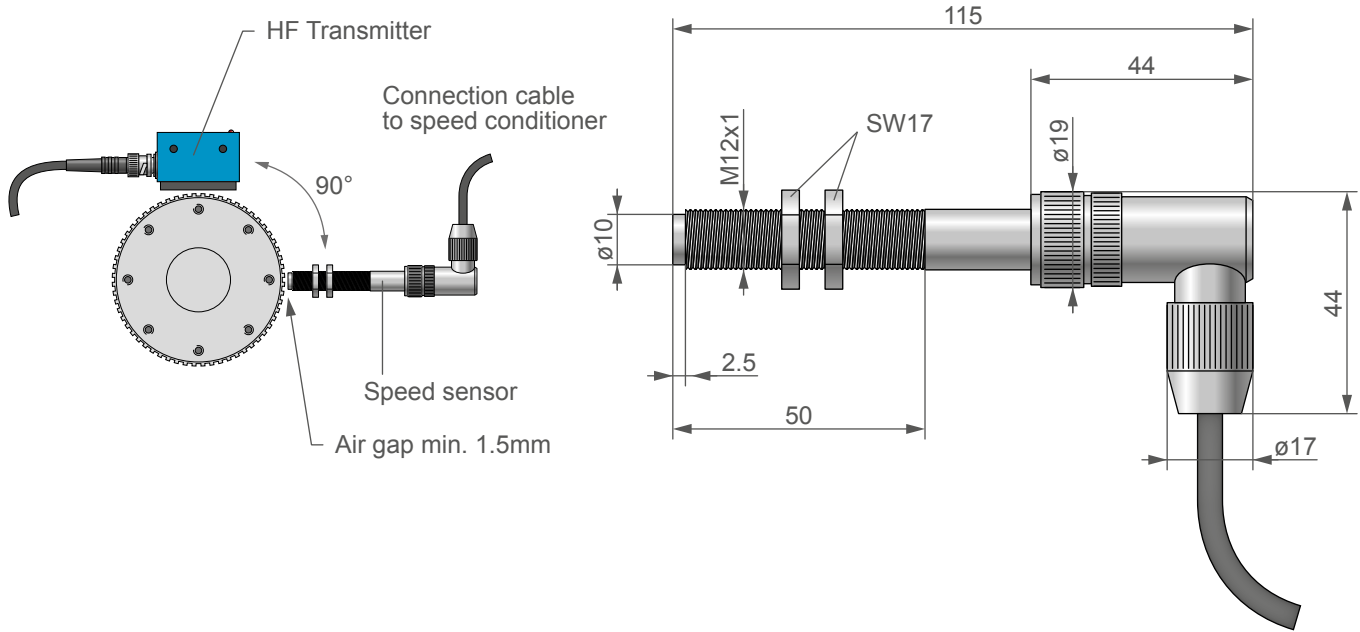

HIGH TEMPERATURE SPEED SENSOR

The high-temperature speed sensor is delivered with TF Torque Flange Sensors when both the speed measurement and extended temperature range options (125°C) are ordered.

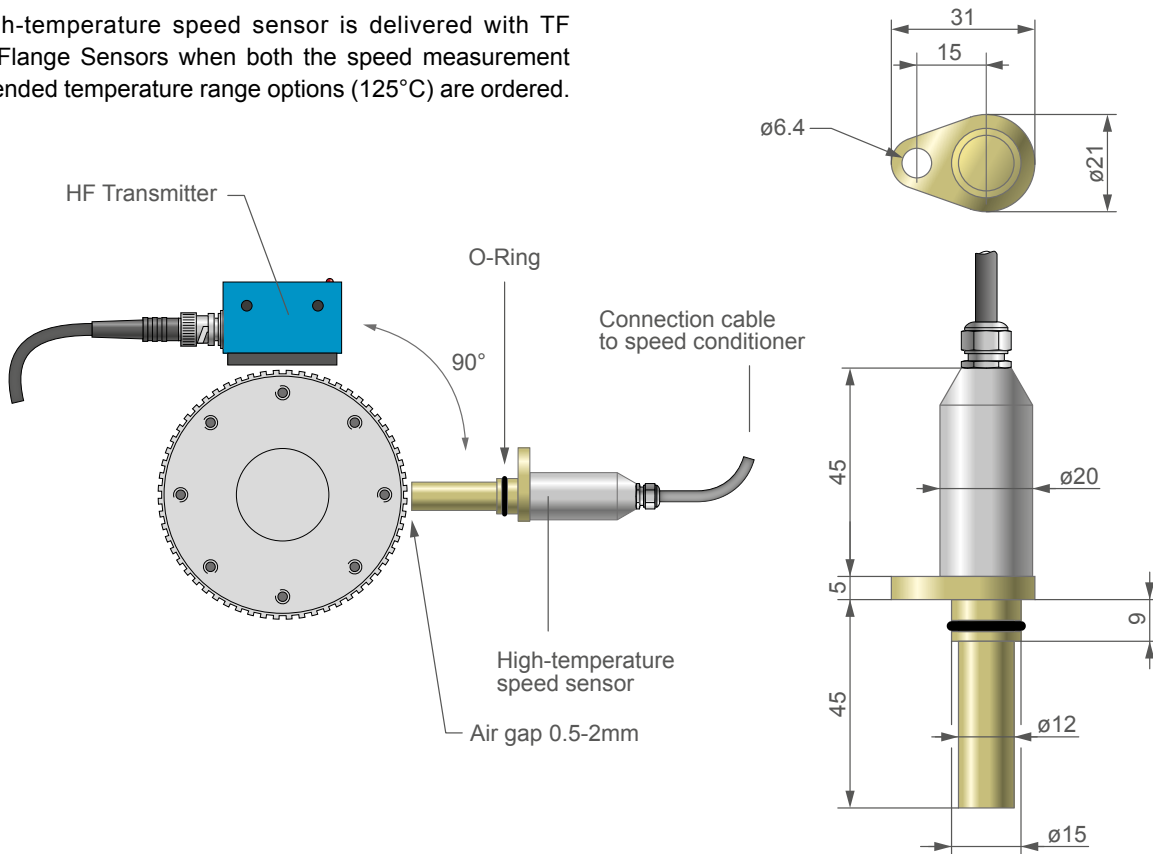

STANDARD CONDITIONER

Conditioner (1.5 W),
for TF 309 to TF 312 and TF 213 to TF 217

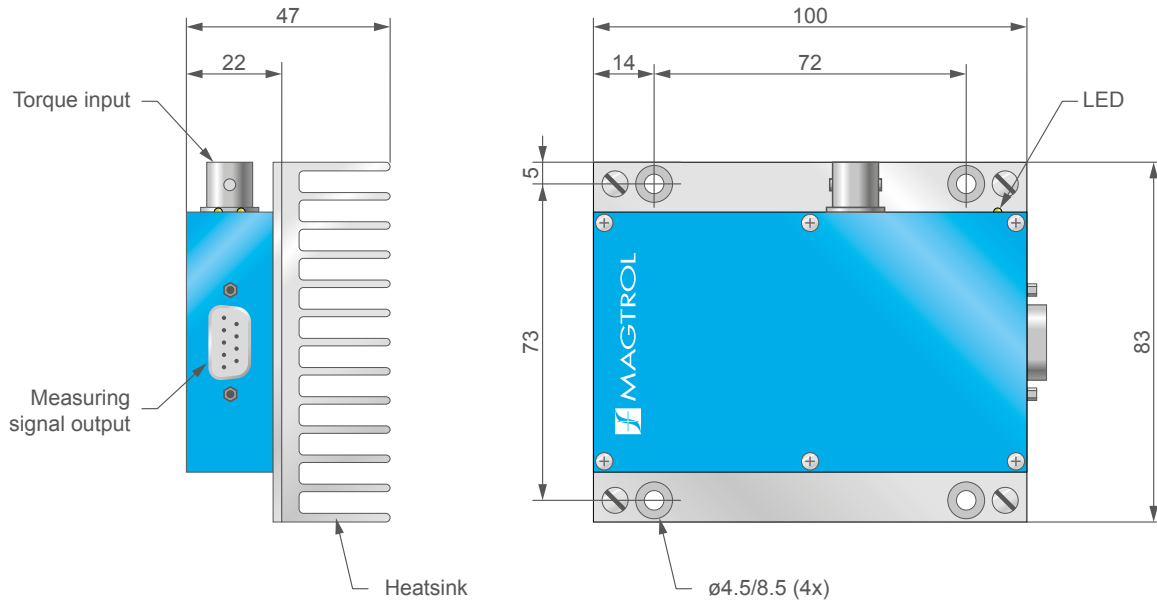

CONDITIONER WITH SPEED OPTION

Conditioner (1.5 W) with speed option,
for TF 309 to TF 312 and TF 213 to TF 217

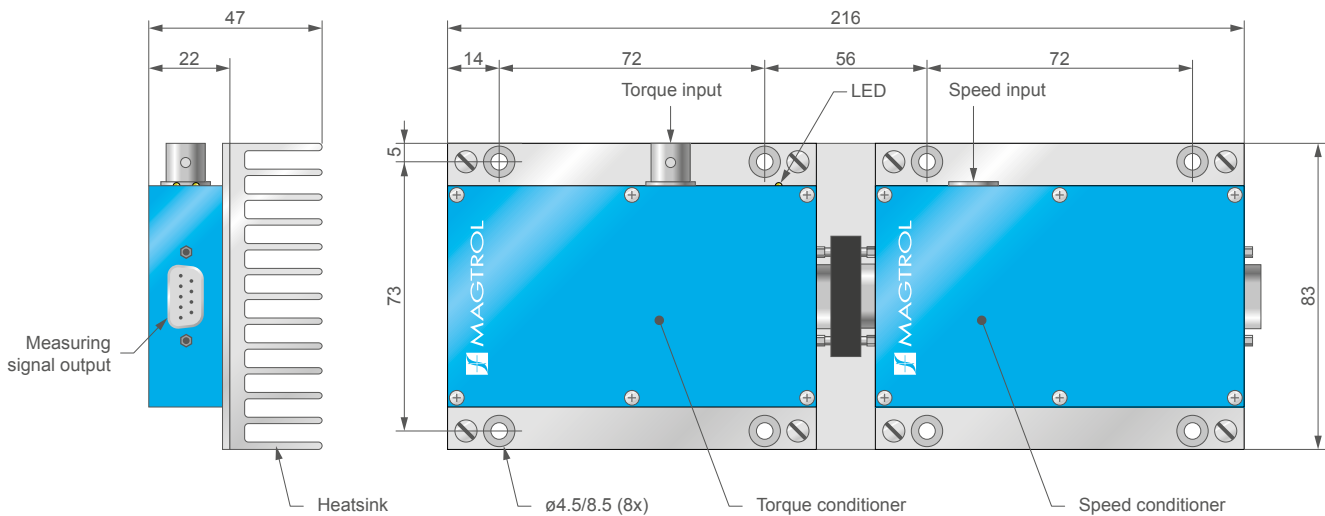

CONDITIONER FOR TF 318-320

Conditioner with speed (5 W),
for TF 318 to TF 320

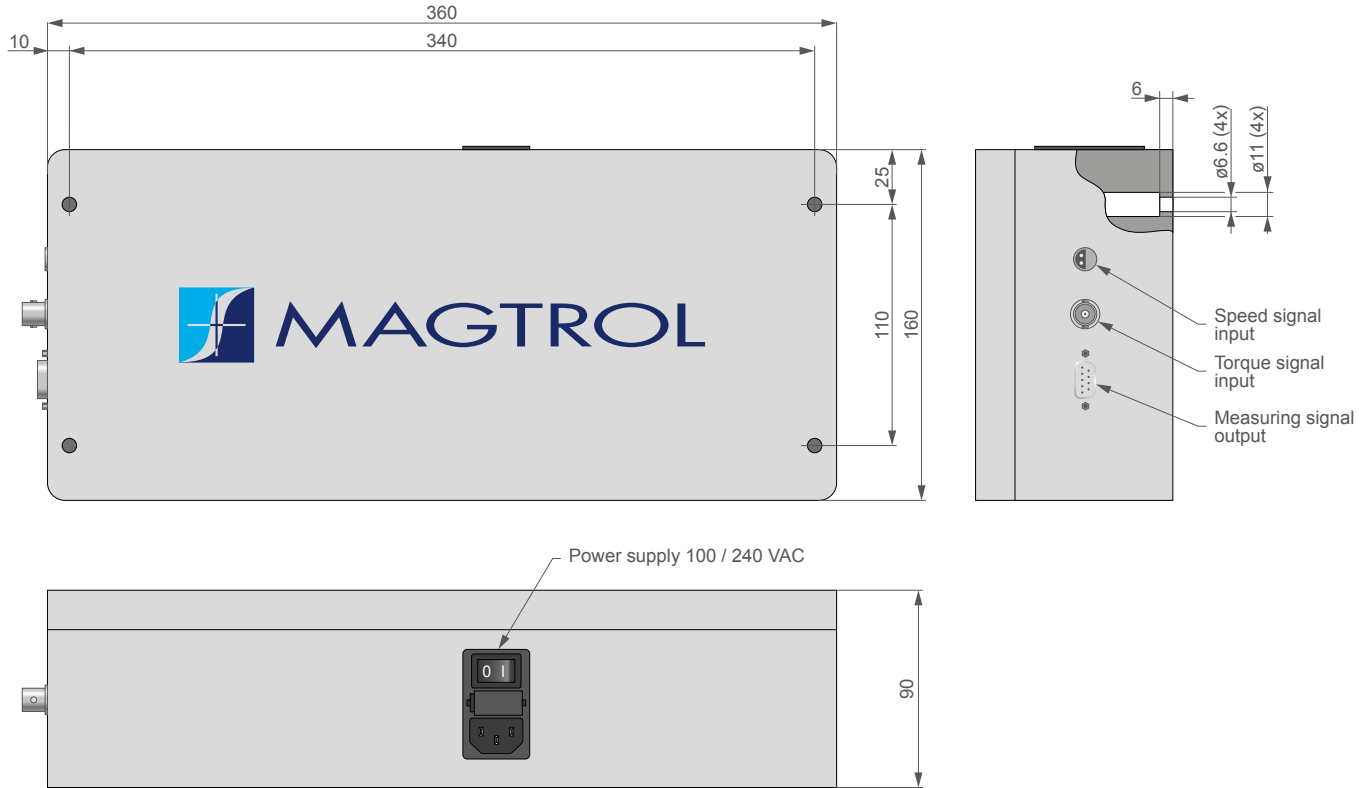

ORDERING INFORMATION

ORDERING NUMBER TF - - - / 0 - X

HS : for high speed series

309, 310, 214, 217, ... , 320 : Model TF or TFHS

- 1 : Basic
- 2 : With speed measurement
- 5 : High temperature version (up to 125°C)
- 6 : Speed measurement & high temperature (up to 125°C)

Example: TF 312 Torque Flange Sensor, high speed version, with speed measurement, would be ordered as: TFHS 312 / 02X.

SYSTEM OPTIONS

MODEL 3411 TORQUE TRANSDUCER DISPLAY

Magtrol offers the Model 3411 Display which supplies power to any TF Sensor and displays torque, speed and mechanical power. Features include:

- Adjustable English, metric and SI torque units
- Large, easy-to-read vacuum fluorescent display
- Built-in self-diagnostic tests
- Overload indication
- Tare function
- Ethernet connectivity
- Torque and speed outputs
- Closed-box calibration
- Includes Magtrol Torque 7 Software

TORQUE 7 SOFTWARE

Magtrol's Torque 7 Software is an easy-to-use Windows® executable program, used to automatically collect torque, speed and mechanical power data. The data can be printed, displayed graphically or quickly saved as a Microsoft® Excel spreadsheet. Standard features of Magtrol's Torque 7 Software include: peak torque capture, multi-axes graphing, measured parameter vs. time, adjustable sampling rates and polynomial curve fitting.

COUPLINGS

For our TF Torque Flange Sensors, Magtrol offers couplings (flexible disc or below type). For more details, please contact your regional sales office.

CABLE ASSEMBLY

ORDERING NUMBER ER 1 - - - - 0 - -

- 16 : 14 Pin connector ^{a)}
- 17 : Pigtail wires

- 1 : Cable length 5 m
- 2 : Cable length 10 m
- 3 : Cable length 20 m

a) For use with 3411 Torque Display or DSP Controller



Fig.7 : 3411 Torque Display



Fig.8 : example of flexible disc coupling