

VI TELEFILTER**Development Specification****TFS 770****1/5****Measurement condition**

Ambient temperature:	23	°C
Input power level:	0	dBm
Terminating impedance: *		
Input:	50	Ω
Output:	50	Ω

Characteristics

Remark:

The maximum attenuation in the pass band is defined as the insertion loss a_e . The nominal frequency f_N is fixed at 770 MHz without any tolerance or limit. The values of absolute attenuation a_{rel} are guaranteed for the whole operating temperature range. The frequency shift of the filter in the operating temperature range is included in the production tolerance scheme.

D a t a			typ. value	tolerance / limit	
Insertion loss	a_e		-	max.	2,5 dB
Nominal frequency	f_N		-	770	MHz
Passband	PB		-	$f_N \pm$	6 MHz
Pass band ripple			-	max.	0,7 dB
Absolute attenuation	a_{abs}				
0 MHz ...	707 MHz		-	min.	45 dB
707 MHz ...	723 MHz		-	min.	40 dB
723 MHz ...	739 MHz		-	min.	35 dB
739 MHz ...	743 MHz		-	min.	25 dB
800 MHz ...	813 MHz		-	min.	15 dB
813 MHz ...	868 MHz		-	min.	30 dB
868 MHz ...	998 MHz		-	min.	50 dB
998 MHz ...	1910 MHz		-	min.	30 dB
Operating temperature range	OTR		-	- 30 °C ... + 85 °C	
Storage temperature range			-	- 40 °C ... + 85 °C	
Temperature coefficient of frequency	TC_f **		T.B.D	ppm/K	-
Input power level			-	max.	15 dBm
VSWR	PB		-	max.	2:1

*) The terminating impedances depend on parasitics and q-values of matching elements and the board used, and are to be understood as reference values only. Should there be additional questions do not hesitate to ask for an application note or contact our design team.

***) $\Delta f_C(\text{Hz}) = TC_f(\text{ppm/K}) \times (T - T_0) \times f_{CAT}(\text{MHz})$.

Generated:**Checked / approved:**

Tele Filter GmbH
Potsdamer Straße 18
D-14 513 TELTOW / Germany
Tel: (+49) 3328 4784-0 / Fax: (+49) 3328 4784-30
E-Mail: tft@telefilter.com

VI TELEFILTER reserves the right to make changes to the product(s) and/or information contained herein without notice. No liability is assumed as a result of their use or application. No rights under any patent accompany the sale of any such product(s) or information.

Construction and pin configuration

(All dimensions in mm)

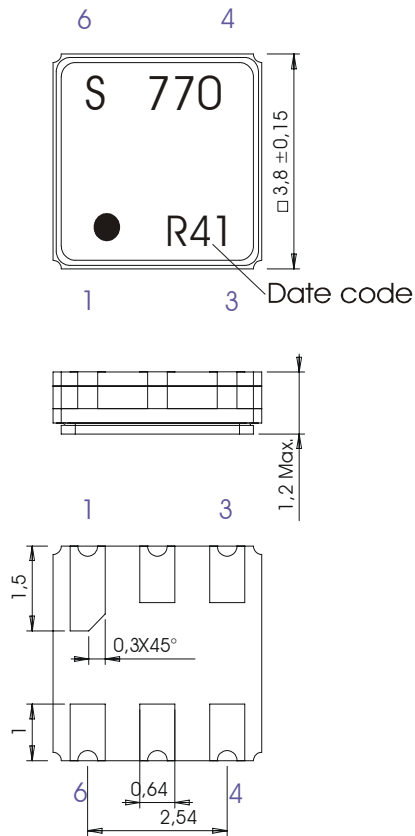

Date code: Year + week

N	2001
P	2002
R	2003
...	

Pin 1	Ground
Pin 2	Input
Pin 3	Ground
Pin 4	Ground
Pin 5	Output
Pin 6	Ground

Stability characteristics

Tele Filter GmbH
Potsdamer Straße 18
D-14 513 TELTOW / Germany
Tel: (+49) 3328 4784-0 / Fax: (+49) 3328 4784-30
E-Mail: tft@telefilter.com

VI TELEFILTER reserves the right to make changes to the product(s) and/or information contained herein without notice. No liability is assumed as a result of their use or application. No rights under any patent accompany the sale of any such product(s) or information.

After the following tests the filter shall meet the whole specification:

1. Shock: 500g, 18 ms, half sine wave, 3 shocks each plane;
DIN IEC 68 T2 - 27
2. Vibration: 10 Hz to 500 Hz, 0,35 mm or 5g respectively, 1 octave per min, 10 cycles per plan, 3 plans;
DIN IEC 68 T2 - 6
3. Change of temperature: -55 °C to 125°C / 30 min. each / 10 cycles
DIN IEC 68 part 2 – 14 Test N
4. Resistance to solder heat (reflow): reflow possible: twice max.;
for temperature conditions, please refer to the attached "Air reflow temperature conditions" on page 4;

Packing

Tape & Reel: IEC 286 - 3, with exception of value for N and minimum bending radius;
tape type II, embossed carrier tape with top cover tape on the upper side;

max. pieces of filters per reel:	3000
reel of empty components at start:	min 300 mm
reel of empty components at start including leader:	min 500 mm
trailer	min 300 mm

Tape (all dimensions in mm)

W	: 12	± 0,3
Po	: 4	± 0,1
Do	: 1,5	+ 0,1
E	: 1,75	± 0,1
F	: 5,5	± 0,05
G (min)	: 0,75	
P2	: 2	± 0,05
P1	: 8	± 0,1
D1(min)	: 1,5	
Ao	: 4,3	± 0,1
Bo	: 4,3	± 0,1
CT	: 9,5	± 0,1

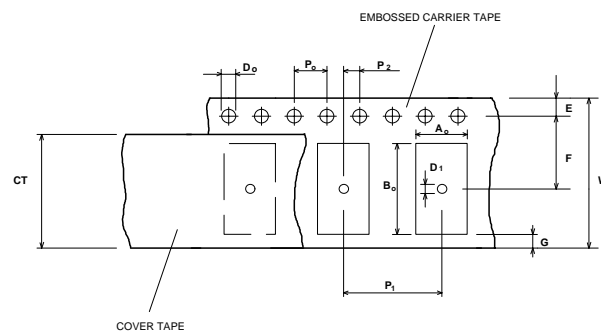

Reel (all dimensions in mm):

A	: 330
W1	: 12,4 + 2,0
W2 (max)	: 18,4
N (min)	: 50
C	: 13 +0,5/-0,2

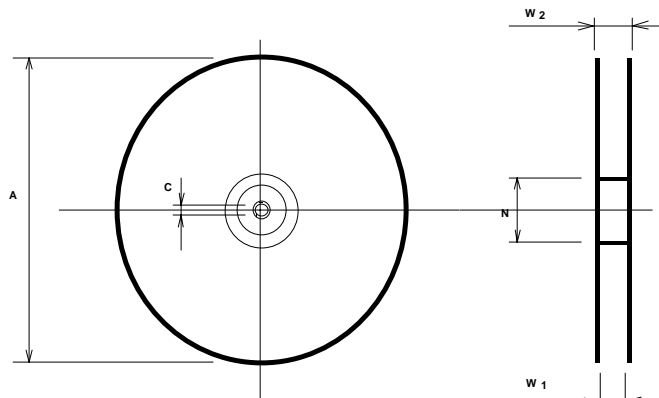

The minimum bending radius is 45 mm. The mounting surface of the filters faces the bottom side of the embossed carrier tape. Markings on the filters can be read if the upper side of the carrier tape is regarded with the sprocket holes on its right.

Tele Filter GmbH
Potsdamer Straße 18
D-14 513 TELTOW / Germany
Tel: (+49) 3328 4784-0 / Fax: (+49) 3328 4784-30
E-Mail: tft@telefilter.com

VI TELEFILTER reserves the right to make changes to the product(s) and/or information contained herein without notice. No liability is assumed as a result of their use or application. No rights under any patent accompany the sale of any such product(s) or information.

Air reflow temperature conditions

1st and 2nd air reflow profile

Name:	pre-heating periods	main-heating periods	peak temperature
Temperature:	150 °C - 170 °C	over 200 °C	255 °C ± 5 °C
Time:	60 sec. - 90 sec.	20 sec. - 25 sec.	

Chip-mount air reflow profile

Table for temperature vs. time during the air reflow process

Tolerance of temperatures: ± 5 °C

time / sec.	temperature / °C	time / sec.	temperature / °C
0	23	140	160
10	34	150	161
20	46	160	164
30	60	170	170
40	80	180	180
50	103	190	205
60	121	195	230
70	134	200	255
80	143	205	230
90	150	210	205
100	154	215	180
110	156	220	165
120	158	230	140
130	159	240	120

Tele Filter GmbH
Potsdamer Straße 18
D-14 513 TELTOW / Germany
Tel: (+49) 3328 4784-0 / Fax: (+49) 3328 4784-30
E-Mail: tft@telefilter.com

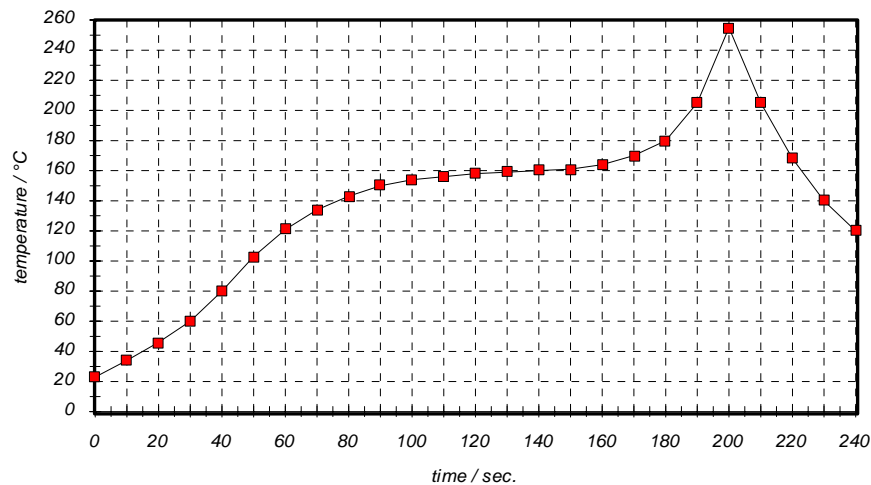
VI TELEFILTER reserves the right to make changes to the product(s) and/or information contained herein without notice. No liability is assumed as a result of their use or application. No rights under any patent accompany the sale of any such product(s) or information.

History

Version	Reason of Changes	Name	Date
1.0	- Generation of development specification	Roizengaft	8.10.2003
1.1	- Changes of remark in characteristics	Roizengaft	13.10.2003

Tele Filter GmbH
Potsdamer Straße 18
D-14 513 TELTOW / Germany
Tel: (+49) 3328 4784-0 / Fax: (+49) 3328 4784-30
E-Mail: tft@telefilter.com

VI TELEFILTER reserves the right to make changes to the product(s) and/or information contained herein without notice. No liability is assumed as a result of their use or application. No rights under any patent accompany the sale of any such product(s) or information.

This datasheet has been download from:

www.datasheetcatalog.com

Datasheets for electronics components.