

HALO Electronics has developed this standard series of 10/100 Isolation Modules to specifically address the isolation, insertion loss and return loss requirements of IEEE 802.3u. All HALO isolation transformers are UL/EN60950 and DEMKO recognized. Available in industry standard and low profile packages. Isolation Modules are available for most LAN IC manufacturer's products. To select the correct Isolation Module please refer to the HALO Electronics [10/100 Selector Guide](#).

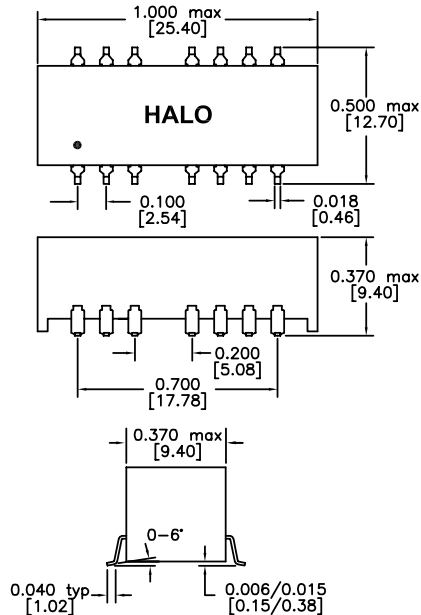

MECHANICAL DIMENSIONS

PACKAGE ND



DIMENSIONS : Inch[mm]
CO-PLANARITY : 0.004[0.10]

PACKAGE NL

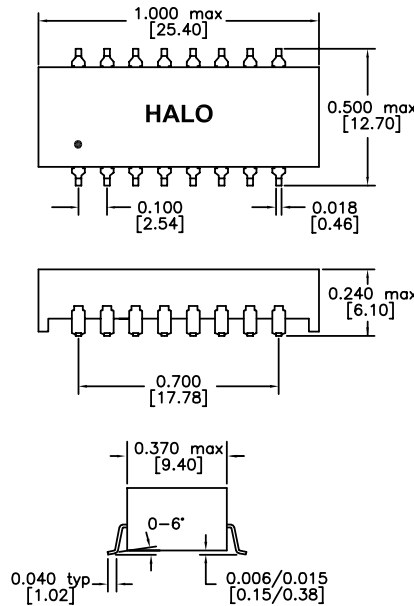

DIMENSIONS : Inch[mm]
CO-PLANARITY : 0.004[0.10]



SCHEMATIC

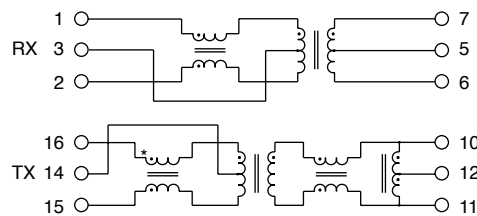

*TG32-3506ND ONLY

Patented Construction

US Pat Nbrs: 5,656,985 6,297,721 B1
6,297,720 B1 6,320,489 B1
6,344,785 B1 6,662,431 B1



Electrical Specifications @ 25°C

Isolation Voltage: 1,500 Vrms
OCL (100KHz, 0.1Vrms, 8mA): 350 μ H Min.
Leakage Inductance (1MHz): 0.4 μ H Max.
Cw/w: 15 pF Typ.
DCR: TG22 0.9 Ω Max.
TG32 1.0 Ω Max.
Rise Time: 2.5 nS Typ.
Insertion Loss (0.1-100MHz): -1.1 dB Max.
Cross Talk (0.1-100 MHz): -38 dB Min.
CMR (0.1-100MHz): TG22 -40 dB Typ.
TG32 -45 dB Typ.

Part Number	Turns Ratio		Return Loss			Package
	TX	RX	0.1-40MHz	50MHz	60-80MHz	
TG22-3506NDRL	1CT:1CT	1CT:1CT	-15.5dB Min.	-13.6dB Min.	-12dB Min.	ND
TG32-3506NDRL	1CT:1CT	1CT:1CT	-15.5dB Min.	-13.6dB Min.	-12dB Min.	ND*
TG22-3506NLRL	1CT:1CT	1CT:1CT	-15.5dB Min.	-13.6dB Min.	-10dB Min.	NL

Note: Please contact the factory for detailed data sheets.

HALO Electronics has developed this standard series of high performance Fast Ethernet Isolation Modules to specifically address the isolation, insertion loss and return loss requirements of IEEE 802.3u. Also compatible with ATM155 applications. All HALO isolation transformers are UL/EN60950 and DEMKO recognized. Available in industry standard and low profile packages. Isolation Modules are available for most LAN IC manufacturer's products. To select the correct Isolation Module please refer to the HALO Electronics [10/100 Selector Guide](#).



MECHANICAL DIMENSIONS

PACKAGE ND

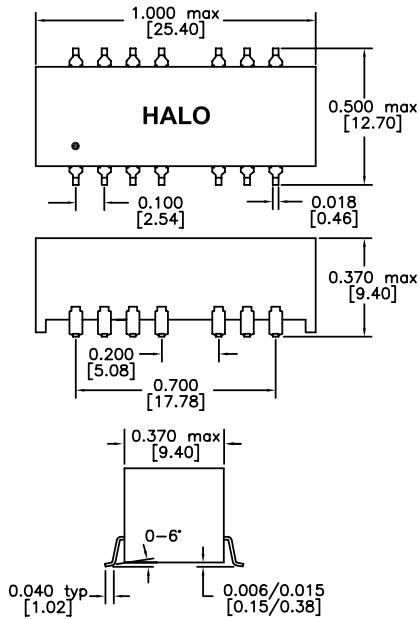

DIMENSIONS : Inch[mm]
CO-PLANARITY : 0.004[0.10]

PACKAGE NL

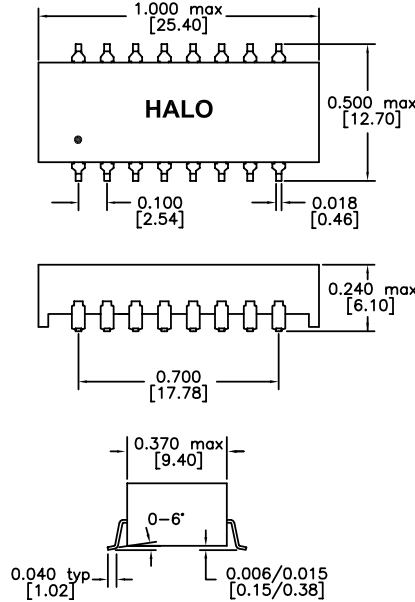

DIMENSIONS : Inch[mm]
CO-PLANARITY : 0.004[0.10]

Patented Construction

US Pat Nbrs: 5,656,985 6,297,721 B1
6,297,720 B1 6,320,489 B1
6,344,785 B1 6,662,431 B1

Electrical Specifications @ 25°C

Isolation Voltage: 1,500 Vrms
OCL (100KHz, 0.1Vrms, 8mA): 350 μ H Min.
Leakage Inductance (1MHz): 0.4 μ H Max.
Cw/w: 15 pF Typ.
DCR: 0.9 Ω Max.
Rise Time: 2.5 nS Typ.
Insertion Loss (0.1-100MHz): -1.1 dB Max.
Cross Talk (0.1-100 MHz): -38 dB Min.
CMR (0.1-100MHz): S010 -45 dB Typ.
S012 -40 dB Typ.

SCHEMATIC

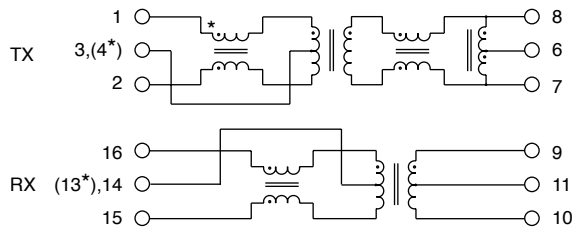

*TG22-S010ND ONLY



Part Number	Turns Ratio		Return Loss			Package
	TX	RX	0.1-40MHz	50MHz	60-80MHz	
TG22-S010NDRL	1CT:1CT	1CT:1CT	-15.5dB Min.	-13.6dB Min.	-12dB Min.	ND*
TG22-S012NDRL	1CT:1CT	1CT:1CT	-15.5dB Min.	-13.6dB Min.	-12dB Min.	ND
TG22-S012NLRL	1CT:1CT	1CT:1CT	-15.5dB Min.	-13.6dB Min.	-10dB Min.	NL

Note: Please contact the factory for detailed data sheets.

HALO Electronics has developed this standard series of 10/100 Isolation Modules to specifically address the isolation, insertion loss and return loss requirements of IEEE 802.3u. All HALO isolation transformers are UL/EN60950 and DEMKO recognized. Available in industry standard and low profile packages. Isolation Modules are available for most LAN IC manufacturer's products. To select the correct Isolation Module please refer to the HALO Electronics [10/100 Selector Guide](#).



MECHANICAL DIMENSIONS

PACKAGE ND

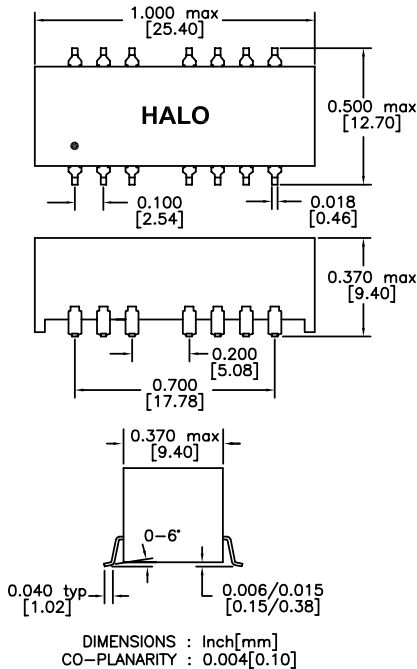

PACKAGE NL

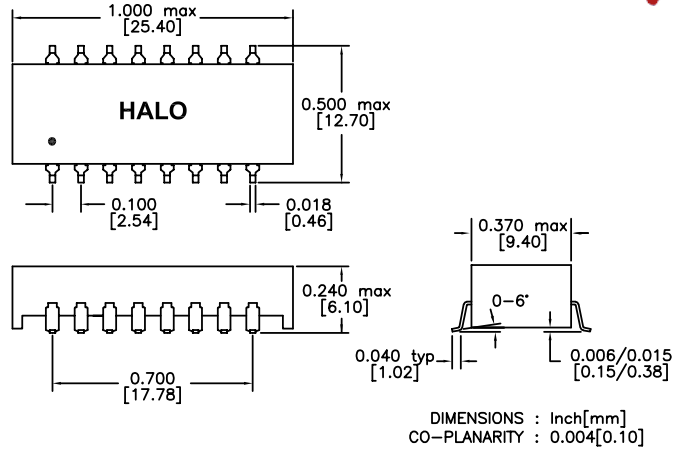

Patented Construction
 US Pat Nbrs: 5,656,985 6,297,721 B1
 6,297,720 B1 6,320,489 B1
 6,344,785 B1 6,662,431 B1

Electrical Specifications @ 25°C

Isolation Voltage: 1,500 Vrms
 OCL (100KHz, 0.1Vrms, 8mA): 350 μ H Min.
 Cw/w: 20 pF Typ.
 DCR: 0.9 Ω Max.
 Rise Time: 2.5 nS Typ.
 Cross Talk (0.1-100 MHz): -38 dB Min.

SCHEMATIC A

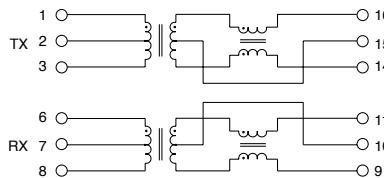

SCHEMATIC B

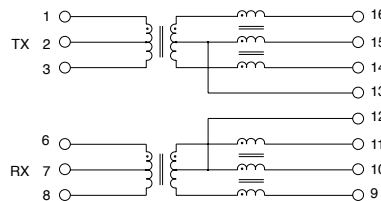

Part Number	Turns Ratio TX	RX	LL (μ H Max.)	(CMR Typ.) (0.1-100MHz)	Schematic	Package
TG22-S131NDRL	$\sqrt{2}$ CT:1CT	1CT:1CT	0.40	-40dB	A	ND
TG22-S131NLRL	$\sqrt{2}$ CT:1CT	1CT:1CT	0.40	-40dB	A	NL
TG22-S133NLRL	$\sqrt{2}$ CT:1CT	1CT:1CT	0.40	-35dB	B	NL
TG22-S136NLRL	1.25CT:1CT	1CT:1CT	0.35	-35dB	B	NL
TG22-S139NDRL	1.25CT:1CT	1CT:1CT	0.35	-40dB	A	ND
TG22-S139NLRL	1.25CT:1CT	1CT:1CT	0.35	-40dB	A	NL

Note: Please contact the factory for detailed data sheets.

HALO Electronics has developed this standard series of 10/100 Isolation Modules to specifically address the isolation, insertion loss and return loss requirements of IEEE 802.3u. All HALO isolation transformers are UL/EN60950 and DEMKO recognized. Available in industry standard and low profile packages. Isolation Modules are available for most LAN IC manufacturer's products. To select the correct Isolation Module please refer to the HALO Electronics [10/100 Selector Guide](#).



MECHANICAL DIMENSIONS

PACKAGE ND

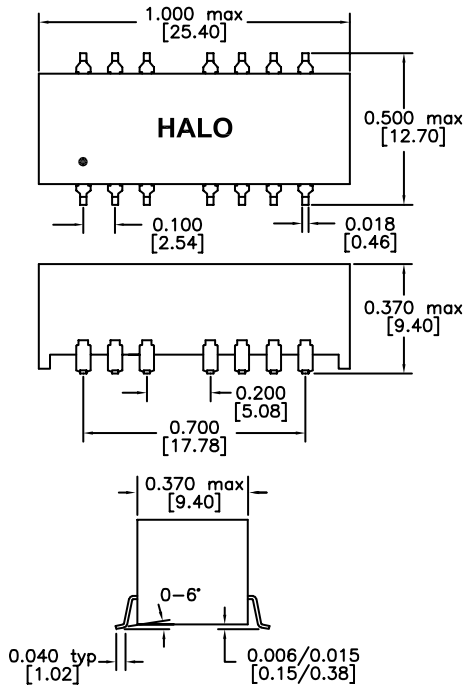

DIMENSIONS : Inch[mm]
CO-PLANARITY : 0.004[0.10]

Electrical Specifications @ 25°C

Isolation Voltage: 1,500 Vrms
 OCL (100KHz, 0.1Vrms, 8mA): 350 μ H Min.
 Cw/w: 20 pF Typ.
 DCR: 0.9 Ω Max.
 Rise Time: 2.5 nS Typ.
 Cross Talk (0.1-100 MHz): -38 dB Min.
 CMR (0.1-100MHz): -40 dB Typ.

PACKAGE NL

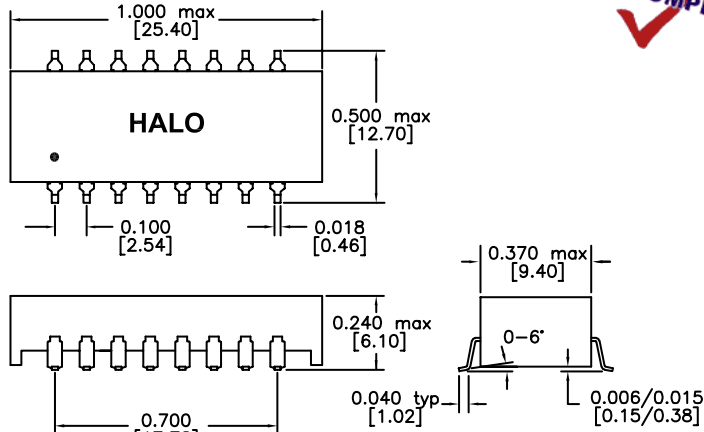

DIMENSIONS : Inch[mm]
CO-PLANARITY : 0.004[0.10]



SCHEMATIC A

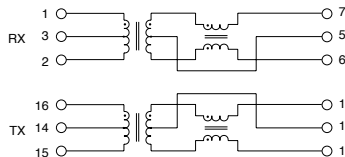

SCHEMATIC B

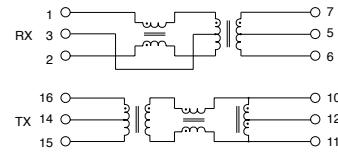

Patented Construction

US Pat Nbrs: 5,656,985 6,297,721 B1
 6,297,720 B1 6,320,489 B1
 6,344,785 B1 6,662,431 B1



Part Number	Turns Ratio		LL (μ H Max.)	(CMR Typ.) Schematic	Package
	TX	RX			
TG22-S132NDRL	$\sqrt{2}$ CT:1CT	1CT:1CT	0.40	A	ND
TG22-S132NLRL	$\sqrt{2}$ CT:1CT	1CT:1CT	0.40	A	NL
TG22-S134NDRL	1.25CT:1CT	1CT:1CT	0.35	A	ND
TG22-S134NLRL	1.25CT:1CT	1CT:1CT	0.35	A	NL
TG22-S137NDRL	1.25CT:1CT	1CT:1CT	0.35	B	ND
TG22-S137NLRL	1.25CT:1CT	1CT:1CT	0.35	B	NL
TG22-S141NDRL	1CT: $\sqrt{2}$ CT	1CT:1CT	0.40	A	ND
TG22-S143NDRL	1CT: $\sqrt{2}$ CT	1CT:1CT	0.40	B	ND

Note: Please contact the factory for detailed data sheets.

HALO Electronics has developed this standard series of 10/100 Isolation Modules to specifically address the isolation, insertion loss and return loss requirements of IEEE 802.3u. All HALO isolation transformers are UL/EN60950 and DEMKO recognized. Available in industry standard and low profile packages. Isolation Modules are available for most LAN IC manufacturer's products. To select the correct Isolation Module please refer to the HALO Electronics [10/100 Selector Guide](#).



MECHANICAL DIMENSIONS

PACKAGE ND

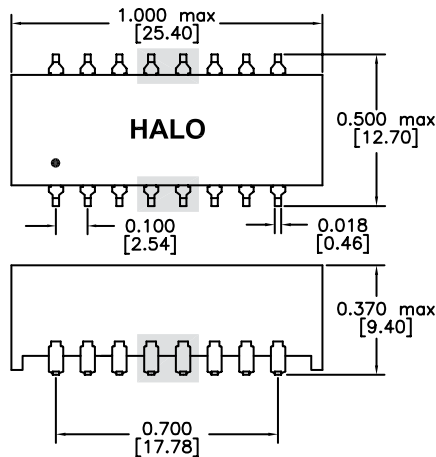

PACKAGE NL

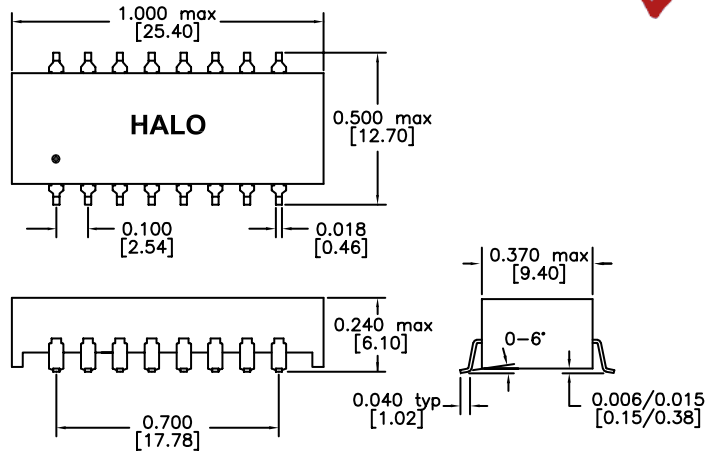

DIMENSIONS : Inch[mm]
CO-PLANARITY : 0.004[0.10]

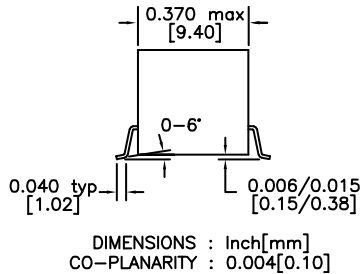

SCHEMATIC A

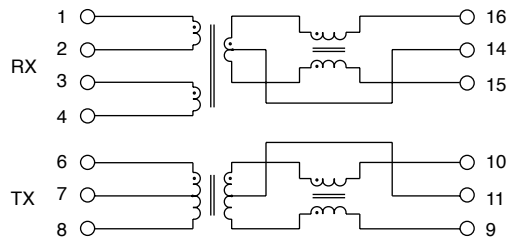

SCHEMATIC B

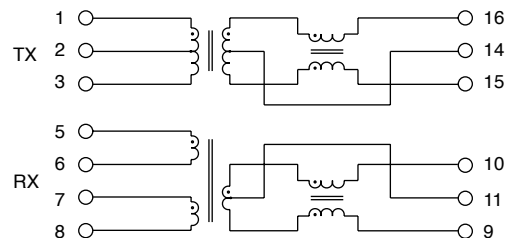

Patented Construction

US Pat Nbrs: 5,656,985 6,297,721 B1
6,297,720 B1 6,320,489 B1
6,344,785 B1 6,662,431 B1

Electrical Specifications @ 25°C

Isolation Voltage: 1,500 Vrms
OCL (100KHz, 0.1Vrms, 8mA): 350 μH Min.
Cw/w: 20 pF Typ.
DCR: 0.9 Ω Max.
Rise Time: 2.5 nS Typ.
Cross Talk (0.1-100 MHz): -38 dB Min.

Part Number	Turns Ratio Package		Schematic	Package	Description
	TX	RX			
TG110-S045NDRL	2CT:1CT	1 : 1 :1CT	A	ND	Pins 5 & 12 omitted
TG110-S045NLRL	2CT:1CT	1 : 1 :1CT	A	NL	-
TG110-S048NDRL	2CT:1CT	1 : 1 :1CT	B	ND	Pins 4 & 13 omitted
TG110-S048NLRL	2CT:1CT	1 : 1 :1CT	B	NL	-

Note: Please contact the factory for detailed data sheets.