

DATA IMAGE CORPORATION

LCD Module Specification

ITEM NO.: TG322400FFNNB-01

Table of Contents

1. COVER & CONTENTS	1
2. RECORD OF REVISION	2
3. GENERAL SPECIFICATIONS	3
4. ABSOLUTE MAXIMUM RATINGS	4
5. ELECTRICAL CHARACTERISTICS	5
6. ELECTRO-OPTICAL CHARACTERISTIC	5
7. TIMING CHARACTERISTICS	7
8. PIN CONNECTIONS	9
9. POWER SUPPLY	9
10. BLOCK DIAGRAM	10
11. QUALITY ASSURANCE	11
12. LOT NUMBERING SYSTEM	16
13. LCM NUMBERING SYSTEM	16
14. PRECAUTIONS IN USE LCM	17
15. OUTLINE DRAWING	18
16. PACKAGE INFORMATION	19

R&D Dept.	Q.C. Dept.	Eng. Dept.	Prod. Dept.
<i>Alex</i>	<i>Eric</i>	<i>Ken</i>	<i>Paul</i>
Version:	Issued Date:	Sheet Code:	Total Pages:
B	2003/3/14		19

2. RECORD OF REVISION

Rev	Date	Item	Page	Comment
B	MAR/14/03	13 11.2.3, 11.3,15	16 14-15,	New model numbering system updated from old P/N# TG32242FH 1.Change: 11.2.3 Inspection Parameters. 2.Add:11.3 Sampling Condition. 3. Modify: OUTLINE DRAWING.

3. GENERAL SPECIFICATION

Display Format : 320 (W) × 240 (H) dots
Dots Pitch : 0.36 (W) × 0.36 (H) mm
Dots Size : 0.34 (W) × 0.34 (H) mm
View Area : 121 (W) × 91.6 (H) mm
General Dimensions : 150 (W) × 106 (H) × 2.7 (T) mm Max.
Weight : g max.

LCD Type : STN Blue STN Yellow FSTN

Polarizer mode : Reflective Transflective

Transmissive Negative

View Angle : 6 O'clock 12 O'clock Others _____

Backlight : LED EL CCFL

Backlight Color : Yellow green Amber Blue Green

White Others

Controller / Driver : Msm6778/Msm6779

Temperature Range : Normal Wide Temperature
Operating 0 to 50°C Operating -20 to 70°C
Storage -20 to 70°C Storage -30 to 80°C

4. ABSOLUTE MAXIMUM RATINGS

4.1 ELECTRICAL ABSOLUTE MAXIMUM RATINGS

$V_{SS}=0V$, $T_a = 25^{\circ}C$

Item	Symbol	Min.	Max.	Unit
Supply Voltage (Logic)	$V_{DD}-V_{SS}$	-0.3	6.5	V
Supply Voltage (LCD Driver)	$V_{DD}-V_{EE}$	0	30	V
Input Voltage	V_I	-0.3	$V_{DD} + 0.3$	V
Operating Temperature	T_{OP}	-20	70	$^{\circ}C$
Storage Temperature	T_{STG}	-30	80	$^{\circ}C$

4.2 ENVIRONMENTAL ABSOLUTE MAXIMUM RATINGS

Item	Operating		Storage		Comment
	(Min.)	Max.)	(Min.)	(Max.)	
Ambient Temp	-20	70	-30	80	Note (1)
Humidity	Note (2)		Note(2)		Without Condensation
Vibration	--	4.9M/S ²	--	19.6M/S ²	XYZ Direction
Shock	--	29.4M/S ²	--	490M/S ²	XYZ Direction

Note(1) $T_a = 0^{\circ}C$: 50Hr Max.

Note(2) $T_a \leq 40^{\circ}C$: 90% RH Max.

$T_a \geq 40^{\circ}C$: Absolute humidity must be lower than the humidity of 90% RH at 40 $^{\circ}C$.

5. ELECTRICAL CHARACTERISTICS

Item	Symbol	Condition	Min.	Typ.	Max.	Unit
Supply Voltage (Logic)	VDD-VSS		4.5	5	5.5	V
Supply Voltage (LCD)	VDD-V ₀	-20°C	26.2	26.7	27.2	V
		-10°C	23	23.5	24	
		0°C	21.9	22.4	22.9	
		10°C	21.2	21.7	22.2	
		25°C	20.5	21.0	21.5	
		50°C	18.9	19.4	19.9	
		70°C	17.8	18.3	18.8	
Input Voltage	V _{IH}	--	0.8*VDD	--	VDD	V
	V _{IL}		VSS	--	0.2*VDD	
Logic Supply Current	I _{DD}	VDD-VSS=5V	--	3.6	--	mA
	I _{EE}	VEE-VSS=-24V	--	3.0	--	

6. ELECTRO-OPTICAL CHARACTERISTICS

ITEM	Symbol	Condition	Min.	Typ.	Max.	Unit	Ref.
Rise Time	Tr	-20°C	--	2000	3500	ms	Note (1)
		0°C		790	1300		
		25°C		200	400		
Fall Time	Tf	-20°C	--	1500	3000	ms	Note (1)
		0°C		670	1100		
		25°C		250	450		
Contrast	CR	25°C	4.0	6.0	--		Note (3)
View Angle	θ _{1-θ2} ∅ _{1, ∅2}	25°C & CR≥2	--	60	--		Note (2)
			--	50	--		
Frame Frequency	Ff	25°C	--	78	--	Hz	

Note (1) & (2) : See next page

Note (3) : Contrast ratio is defined under the following condition:

$$CR = \frac{\text{Brightness of non-selected condition}}{\text{Brightness of selected condition}}$$

- (a). Temperature ----- 25°C
- (b). Frame frequency ---- 78Hz
- (c). Viewing angle ----- θ= 0°, ∅ = 0°
- (d). Operating voltage --- 21.0V

Note (1) Response time is measured as the shortest period of time possible between the change in state of an LCD segment as demonstrated below:

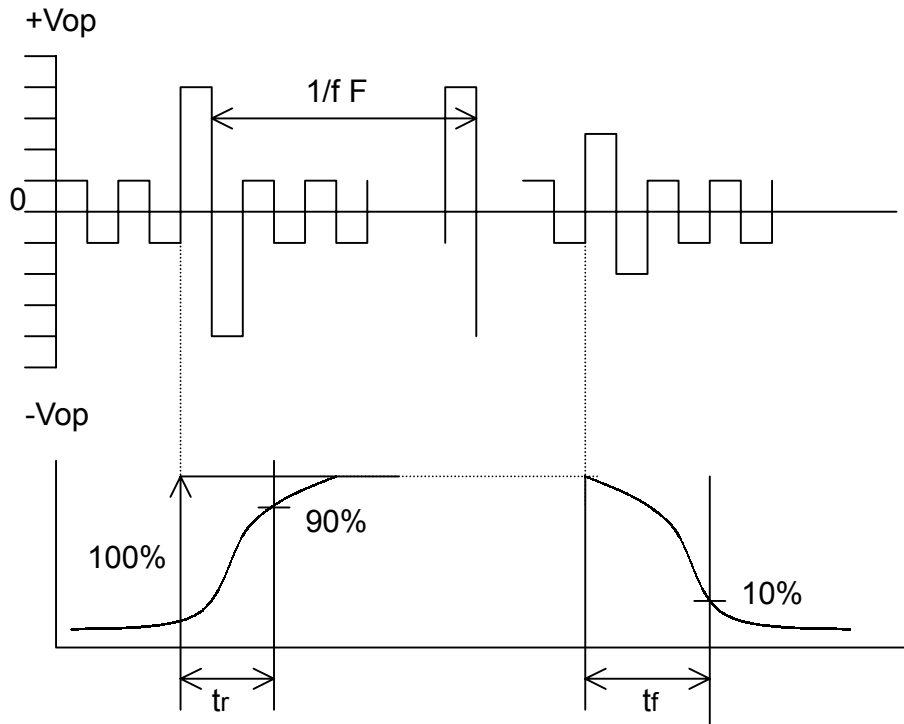

Condition:

- (a) . Temperature ----- $25^{\circ}C$
- (b) . Frame frequency ----- 78Hz
- (c) . View Angle ----- $\theta = 0^{\circ}$, $\phi = 0^{\circ}$
- (d) . Operating voltage ----- 21.0V

Note (2) Definition of View Angle

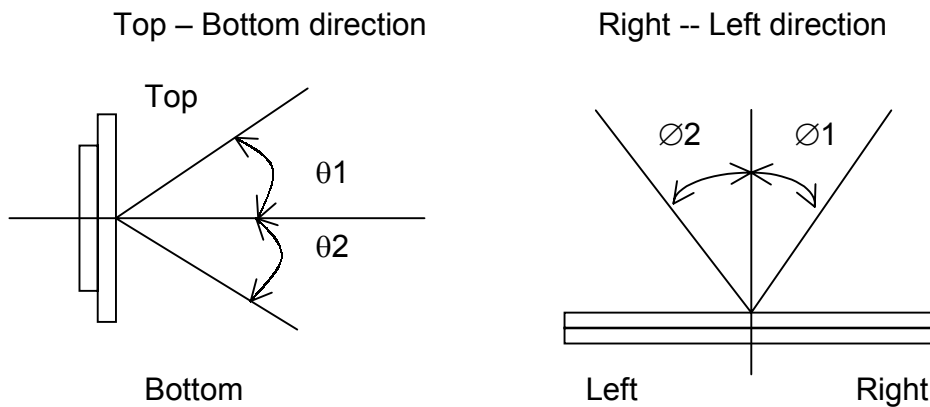

7. TIMING CHARACTERISTIC

Switching Characteristics

($V_{DD}=2.7$ to 5.5 V, $T_a=-20$ to $+75^\circ\text{C}$, $C_L=15$ pF)

Parameter	Symbol	Condition	Min.	Typ.	Max.	Unit
IO_1, IO_{61} (IO_{60}, IO_{120})	t_{PLH}	—	*1	—	3	μs
"H", "L" Propagation Delay Time	t_{PHL}	—	—	—	—	—
Clock Frequency	f_{CP}	—	—	—	1	MHz
CP Pulse Width	t_{WCP}	—	63	—	—	ns
Data Setup Time $IO_1, IO_{61} \rightarrow CP$ ($IO_{60}, IO_{120} \rightarrow CP$)	t_{SETUP}	—	100	—	—	ns
Data Hold Time $CP \rightarrow IO_1, IO_{61}$ ($CP \rightarrow IO_{60}, IO_{120}$)	t_{HOLD}	—	100	—	—	ns
CP Rise, Fall Time	t_r (CP) t_f (CP)	—	—	—	20	ns

*1 The relationship between t_{PLH} (t_{PLH}) Min. and t_{HOLD} Min. satisfies the operation in a cascade connection state.

Note 1: When display is controlled by $\overline{DISPOFF}$ pin, CP rise and fall time must be $\leq 1 \mu\text{s}$.

Note 2: The above values are guaranteed when TCP is protected from light.

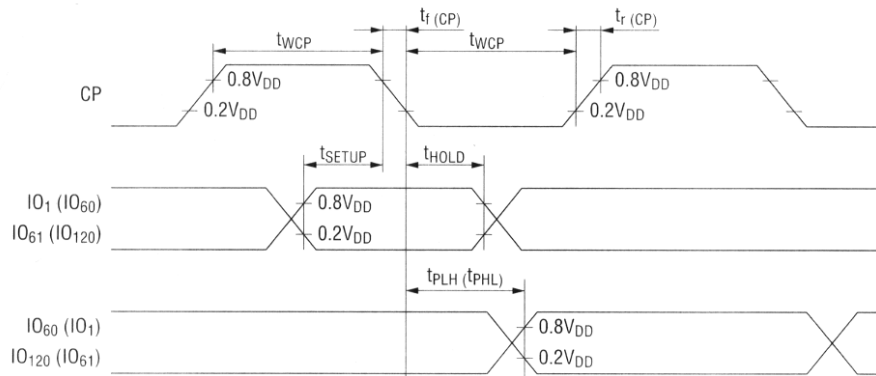

Switching Characteristics

($4.5 \leq V_{DD} \leq 5.5$ V, $T_a = -20$ to $+75^\circ\text{C}$)

Parameter	Symbol	Condition	Min.	Typ.	Max.	Unit
Clock Frequency	f_{CP}	DUTY=50%, $V_{DD}=4.5$ V	—	—	6.5	MHz
Clock Pulse Width	t_{W1}	—	56	—	—	ns
Load Pulse Width	t_{W2}	—	70	—	—	ns
Clock Pulse Rise/Fall Time	t_r, t_f	—	—	—	20	ns
Data Set-up Time	t_{DSU}	—	50	—	—	ns
Data Hold Time	t_{DHD}	—	40	—	—	ns
Clock Load Time 1	t_{CL1}	—	0	—	—	ns
Clock Load Time 2	t_{CL2}	—	65	—	—	ns
Load Clock Time 1	t_{LC1}	—	65	—	—	ns
Load Clock Time 2	t_{LC2}	—	65	—	—	ns
Propagation Delay Time	t_{PHL}	$C_L=15$ pF	—	—	236	ns
EIO ₁ , EIO ₂ Set-up Time	t_{ESU}	—	50	—	—	ns
EIO ₁ , EIO ₂ Hold Time	t_{EHD}	—	50	—	—	ns

Note: The above values are guaranteed when TCP is protected from light.

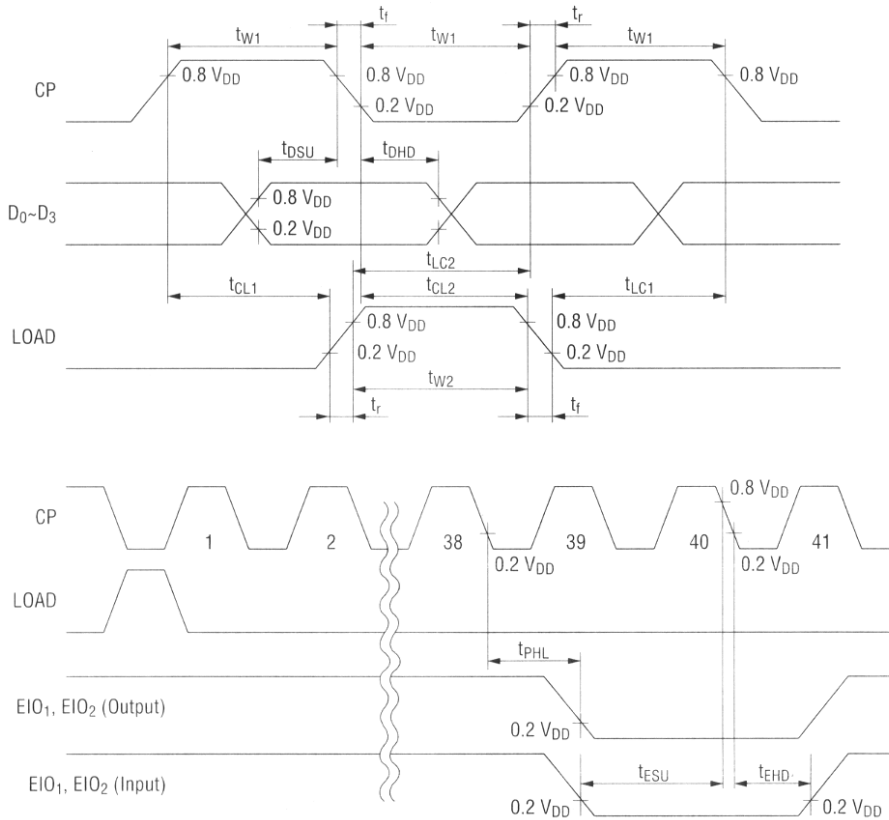

8. PIN CONNECTIONS

NO	Symbol	Function
1	VO	Voltage input for LCD contrast
2	VEE	Negative Voltage input
3	D3	Data bus line
4	D2	
5	D1	
6	D0	
7	NC	No connection
8	VSS	Ground (0V)
9	VDD	Logic power input
10	CP2	Data shift pulse.(CP)
11	CP1	Data latch pulse.(Load)
12	S	First line mark of common signal

9. POWER SUPPLY

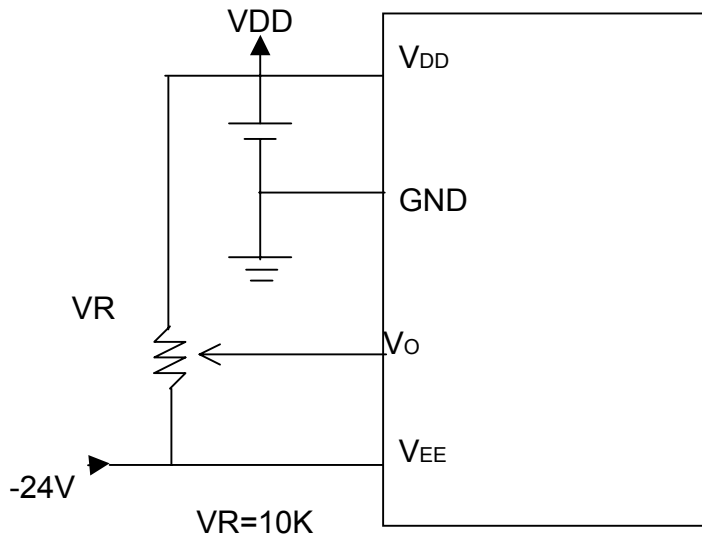

10. BLOCK DIAGRAM

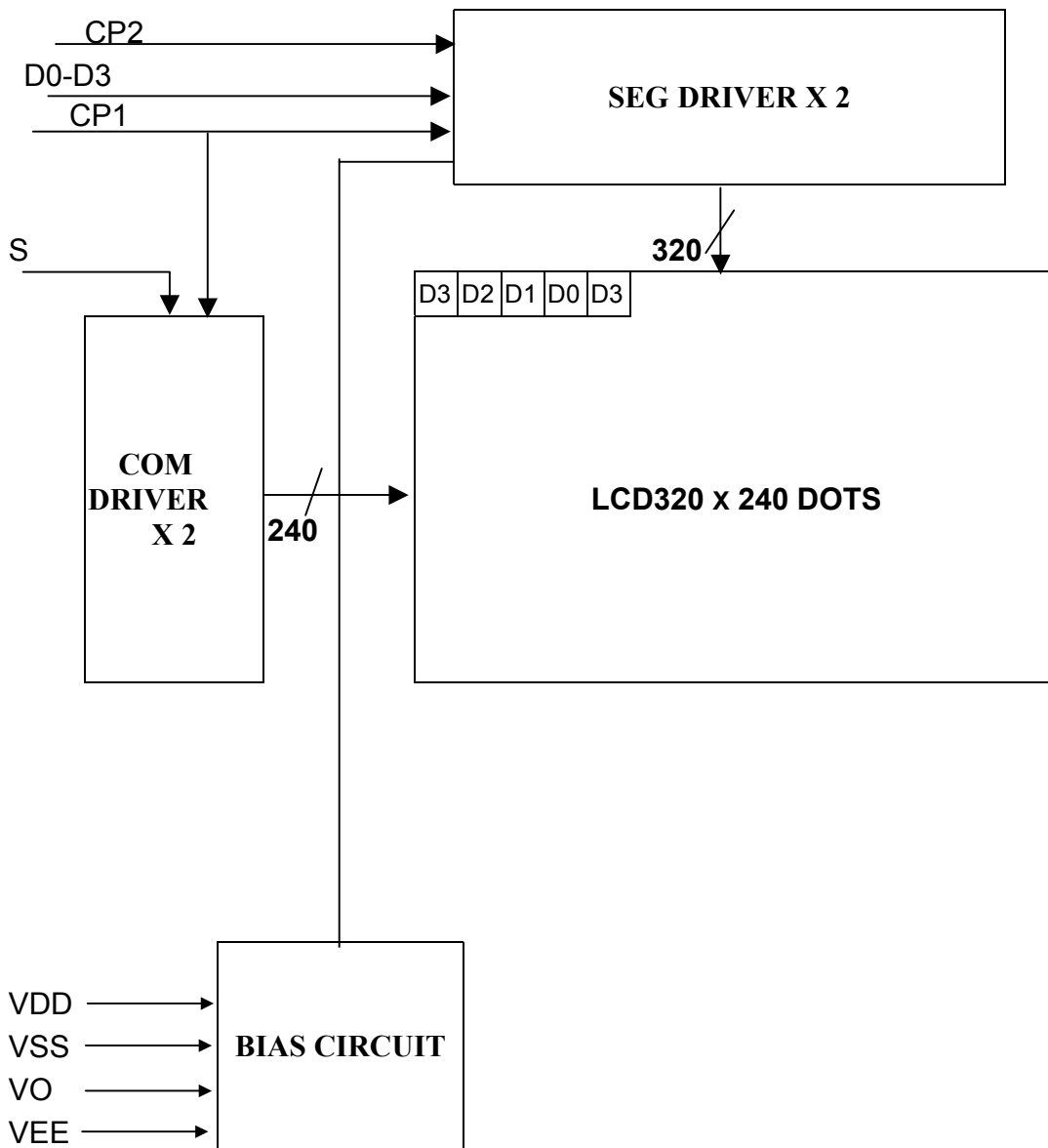

11. QUALITY ASSURANCE

11.1 Test Condition

11.1.1 Temperature and Humidity(Ambient Temperature)

Temperature : 20 ± 5°C
 Humidity : 65 ± 5%

11.1.2 Operation

Unless specified otherwise, test will be conducted with LCM in operation.

11.1.3 Container

Unless specified otherwise, vibration test will be conducted on module only.

11.1.4 Test Frequency

Single cycle.

11.1.5 Test Method

A. Thermal Cycle (Humid) Requirements

Samples functionally tested at low humidity dwell in following profile:			
Ramp	31 deg C	88% RH	7 hours
Dwell	31 deg C	88% RH	5 hours
Ramp	41 deg C	59% RH	7 hours
Dwell	41 deg C	59% RH	4 hours
Loop 14 cycles			

B. Thermal Cycling (Non-Operating) Requirements

Functional test after entire test complete and 4 hours of stabilization.					
#1	Ramp	-25 deg C 15 min	#2	Ramp	-40 deg C 15 min
	Dwell	-25 deg C 80 min		Dwell	-40 deg C 80 min
	Ramp	70 deg C 30 min		Ramp	85 deg C 30 min
	Dwell	70 deg C 85 min		Dwell	85 deg C 85 min
	Ramp	25 deg C 15 min		Ramp	25 deg C 15 min
Loop 84 times - For First 3 days run profile #1. For remainder of test run profile #2					

C. Thermal Cycle (Operating) Requirements

Verify functionality every 3 days of 4 units.								
#1	Ramp	-10 deg C 12 min	#2	Ramp	12 min	#3	Ramp	-30 deg C 12 min
	Dwell	-10 deg C 85 min		Dwell	85 min		Dwell	-30 deg C 85 min
	Ramp	60 deg C 25 min		Ramp	25 min		Ramp	70 deg C 25 min
	Dwell	60 deg C 91 min		Dwell	91 min		Dwell	70 deg C 91 min
	Ramp	25 deg C 15 min		Ramp	15 min		Ramp	25 deg C 15 min
Note: LCDs not required to work at -30 deg C.								

D. Electrical Life Requirements

Functional test done daily inside dwell of following profile:		
Ramp	70 deg C	30 min
Dwell	70 deg C	324 hours
Ramp	25 deg C	30 min

E. Drop Requirements

48" to 1/2" steel plate all faces and corners in the following order:	
Sample 1 order of drop:	Sample 2 order of drop:
Corner - top right	Back (LCD up)
Corner - top left	Front (LCD down)
Corner - bottom right	Right face
Corner - bottom left	Left face
Top face	Bottom face
Bottom face	Top face
Left face	Corner - bottom left
Right face	Corner - bottom right
Front (LCD down)	Corner - top left
Back (LCD up)	Corner - top right
* Red is non-functional failure, bold is functional failure - data is from all four samples tested	

F. Vibration Requirements

FREQUENCY	10 TO 57 Hz
AMPLITUDE	0.075 mm
FREQUENCY	57 TO 500 Hz
ACCELERATION	9.8m/S ²
INTERVAL	10Hz-500Hz-10Hz/11min per cycle
DURATION	12 CYCLES IN EACH DIRECTION(X/Y/Z)

11.2 Inspection condition

11.2.1 Inspection conditions

The LCD shall be inspected under 40W white fluorescent light.

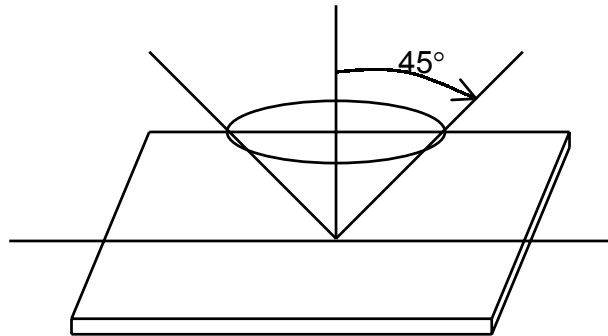

11.2.2 Definition of applicable Zones

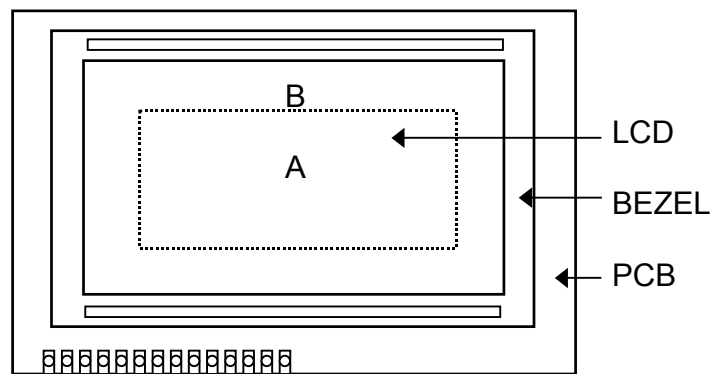

A : Display Area
B : Non-Display Area

11.2.3 Inspection Parameters

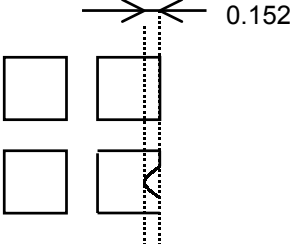
No.	Parameter	Criteria																												
1	Black or White spots	<table border="1"> <thead> <tr> <th rowspan="2">Zone Dimension</th> <th colspan="2">Acceptable number</th> <th rowspan="2">Class Of Defects</th> <th rowspan="2">AQL Level</th> </tr> <tr> <th>A</th> <th>B</th> </tr> </thead> <tbody> <tr> <td>D < 0.15</td> <td>*</td> <td>*</td> <td rowspan="4">Minor</td> <td rowspan="4">2.5</td> </tr> <tr> <td>0.15 ≤ D < 0.2</td> <td>4</td> <td>4</td> </tr> <tr> <td>0.2 ≤ D ≤ 0.25</td> <td>2</td> <td>2</td> </tr> <tr> <td>D ≤ 0.3</td> <td>0</td> <td>1</td> </tr> </tbody> </table> <p>D = (Long + Short) / 2 * : Disregard</p>	Zone Dimension	Acceptable number		Class Of Defects	AQL Level	A	B	D < 0.15	*	*	Minor	2.5	0.15 ≤ D < 0.2	4	4	0.2 ≤ D ≤ 0.25	2	2	D ≤ 0.3	0	1							
Zone Dimension	Acceptable number			Class Of Defects	AQL Level																									
	A	B																												
D < 0.15	*	*	Minor	2.5																										
0.15 ≤ D < 0.2	4	4																												
0.2 ≤ D ≤ 0.25	2	2																												
D ≤ 0.3	0	1																												
2	Scratch, Substances	<table border="1"> <thead> <tr> <th colspan="2">Zone</th> <th colspan="2">Acceptable number</th> <th rowspan="2">Class Of Defects</th> <th rowspan="2">AQL Level</th> </tr> <tr> <th>X (mm)</th> <th>Y(mm)</th> <th>A</th> <th>B</th> </tr> </thead> <tbody> <tr> <td>*</td> <td>0.04 ≥ W</td> <td>*</td> <td>*</td> <td rowspan="4">Minor</td> <td rowspan="4">2.5</td> </tr> <tr> <td>3.0 ≥ L</td> <td>0.06 ≥ W</td> <td>4</td> <td>4</td> </tr> <tr> <td>2.0 ≥ L</td> <td>0.08 ≥ W</td> <td>2</td> <td>3</td> </tr> <tr> <td>—</td> <td>0.1 < W</td> <td>0</td> <td>1</td> </tr> </tbody> </table> <p>X : Length Y : Width * : Disregard Total defects should not exceed 4/module</p>	Zone		Acceptable number		Class Of Defects	AQL Level	X (mm)	Y(mm)	A	B	*	0.04 ≥ W	*	*	Minor	2.5	3.0 ≥ L	0.06 ≥ W	4	4	2.0 ≥ L	0.08 ≥ W	2	3	—	0.1 < W	0	1
Zone		Acceptable number		Class Of Defects	AQL Level																									
X (mm)	Y(mm)	A	B																											
*	0.04 ≥ W	*	*	Minor	2.5																									
3.0 ≥ L	0.06 ≥ W	4	4																											
2.0 ≥ L	0.08 ≥ W	2	3																											
—	0.1 < W	0	1																											
3	Air Bubbles (between glass & polarizer)	<table border="1"> <thead> <tr> <th rowspan="2">Zone Dimension</th> <th colspan="2">Acceptable number</th> <th rowspan="2">Class of Defects</th> <th rowspan="2">AQL Level</th> </tr> <tr> <th>A</th> <th>B</th> </tr> </thead> <tbody> <tr> <td>D ≤ 0.15</td> <td>*</td> <td>*</td> <td rowspan="3">Minor</td> <td rowspan="3">2.5</td> </tr> <tr> <td>0.15 < D ≤ 0.25</td> <td>2</td> <td>*</td> </tr> <tr> <td>0.25 < D</td> <td>0</td> <td>1</td> </tr> </tbody> </table> <p>* : Disregard Total defects shall not excess 3/module.</p>	Zone Dimension	Acceptable number		Class of Defects	AQL Level	A	B	D ≤ 0.15	*	*	Minor	2.5	0.15 < D ≤ 0.25	2	*	0.25 < D	0	1										
Zone Dimension	Acceptable number			Class of Defects	AQL Level																									
	A	B																												
D ≤ 0.15	*	*	Minor	2.5																										
0.15 < D ≤ 0.25	2	*																												
0.25 < D	0	1																												
4	Uniformity of Pixel	<p>(1) Pixel shape (with Dent)</p> 																												

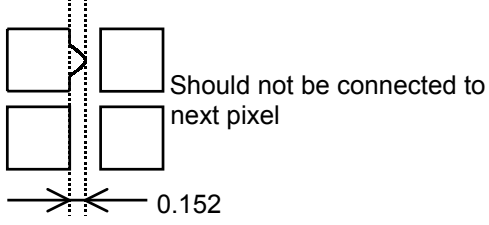
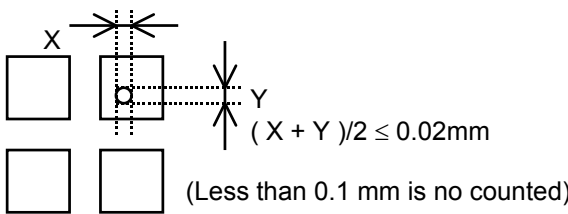
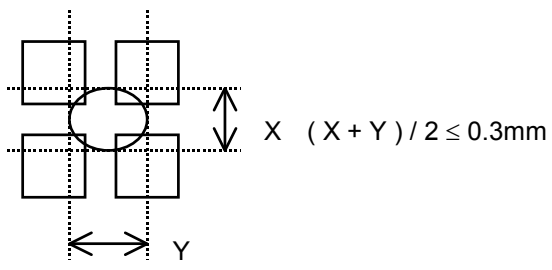
4	Uniformity of Pixel	<p>(2) Pixel shape (with Projection)</p>  <p>(3) Pin hole</p>  <p>(4) Deformation</p>  <p>Total acceptable number : 1/pixel, 5/cell</p>	
		Class of defects	Major
	Minor	<p>AQL 2.5% It is a defect that will not result in functioning problem with deviation classified.</p>	

11.3 Sampling Condition

Unless otherwise agree in written, the sampling inspection shall be applied to the incoming inspection of customer.

Lot size: Quantity of shipment lot per model.

Sampling type: normal inspection, single sampling

Inspection level: Level II

Sampling table: MIL-STD-105E

12. LOT NUMBERING SYSTEM

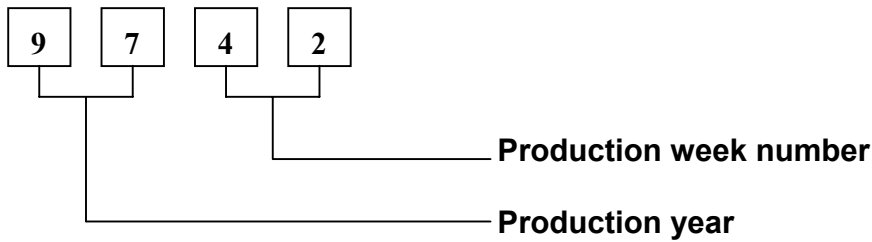

13. LCM NUMBERING SYSTEM

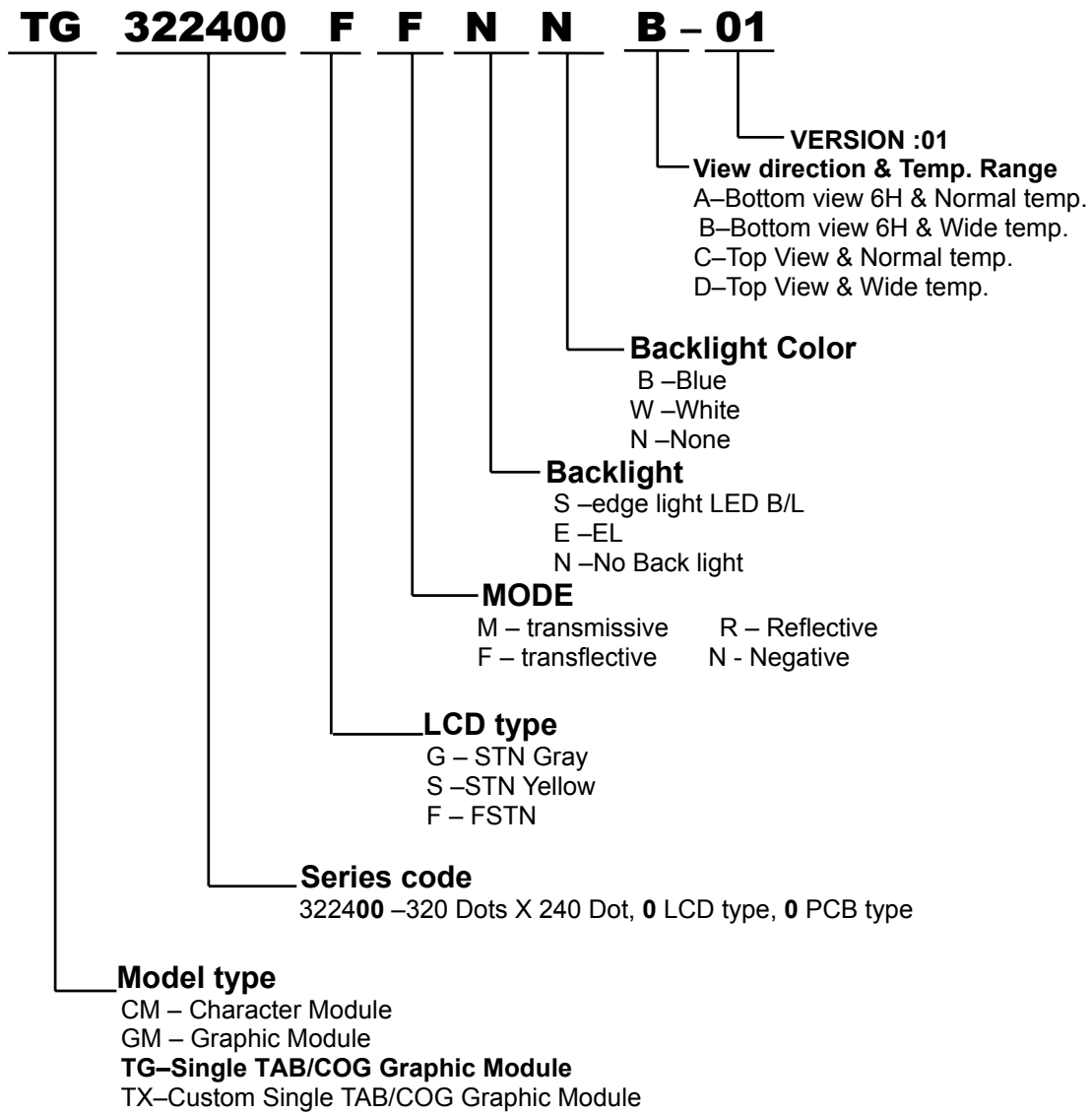

14. PRECAUTION FOR USING LCM

1. LIQUID CRYSTAL DISPLAY (LCD)

LCD is made up of glass, organic sealant, organic fluid, and polymer based polarizers. The following precautions should be taken when handling,

- (1). Keep the temperature within range of use and storage. Excessive temperature and humidity could cause polarization degradation, polarizer peel off or bubble.
- (2). Do not contact the exposed polarizers with anything harder than an HB pencil lead. To clean dust off the display surface, wipe gently with cotton, chamois or other soft material soaked in petroleum benzin.
- (3). Wipe off saliva or water drops immediately. Contact with water over a long period of time may cause polarizer deformation or color fading, while an active LCD with water condensation on its surface will cause corrosion of ITO electrodes.
- (4). Glass can be easily chipped or cracked from rough handling, especially at corners and edges.
- (5). Do not drive LCD with DC voltage.

2. Liquid Crystal Display Modules

2.1 Mechanical Considerations

LCM are assembled and adjusted with a high degree of precision. Avoid excessive shocks and do not make any alterations or modifications. The following should be noted.

- (1). Do not tamper in any way with the tabs on the metal frame.
- (2). Do not modify the PCB by drilling extra holes, changing its outline, moving its components or modifying its pattern.
- (3). Do not touch the elastomer connector, especially insert an backlight panel (for example, EL).
- (4). When mounting a LCM make sure that the PCB is not under any stress such as bending or twisting. Elastomer contacts are very delicate and missing pixels could result from slight dislocation of any of the elements.
- (5). Avoid pressing on the metal bezel, otherwise the elastomer connector could be deformed and lose contact, resulting in missing pixels.

2.2. Static Electricity

LCM contains CMOS LSI's and the same precaution for such devices should apply, namely

- (1). The operator should be grounded whenever he/she comes into contact with the module. Never touch any of the conductive parts such as the LSI pads, the copper leads on the PCB and the interface terminals with any parts of the human body.
- (2). The modules should be kept in antistatic bags or other containers resistant to static for storage.
- (3). Only properly grounded soldering irons should be used.
- (4). If an electric screwdriver is used, it should be well grounded and shielded from commutator sparks.

(5) The normal static prevention measures should be observed for work clothes and working benches; for the latter conductive (rubber) mat is recommended.

(6). Since dry air is inductive to static, a relative humidity of 50-60% is recommended.

2.3 Soldering

- (1). Solder only to the I/O terminals.
- (2). Use only soldering irons with proper grounding and no leakage.
- (3). Soldering temperature : $280^{\circ}\text{C} \pm 10^{\circ}\text{C}$
- (4). Soldering time: 3 to 4 sec.
- (5). Use eutectic solder with resin flux fill.
- (6). If flux is used, the LCD surface should be covered to avoid flux spatters. Flux residue should be removed after wards.

2.4 Operation

- (1). The viewing angle can be adjusted by varying the LCD driving voltage V0.
- (2). Driving voltage should be kept within specified range; excess voltage shortens display life.
- (3). Response time increases with decrease in temperature.
- (4). Display may turn black or dark blue at temperatures above its operational range; this is (however not pressing on the viewing area) may cause the segments to appear "fractured".
- (5). Mechanical disturbance during operation (such as pressing on the viewing area) may cause the segments to appear "fractured".

2.5 Storage

If any fluid leaks out of a damaged glass cell, wash off any human part that comes into contact with soap and water. Never swallow the fluid. The toxicity is extremely low but caution should be exercised at all the time.

2.6 Limited Warranty

Unless otherwise agreed between DATA IMAGE and customer, DATA IMAGE will replace or repair any of its LCD and LCM which is found to be defective electrically and visually when inspected in accordance with DATA IMAGE acceptance standards, for a period on one year from date of shipment. Confirmation of such date shall be based on freight documents. The warranty liability of DATA IMAGE is limited to repair and/or replacement on the terms set forth above. DATA IMAGE will not responsible for any subsequent or consequential events.

15 OUTLINE DRAWING

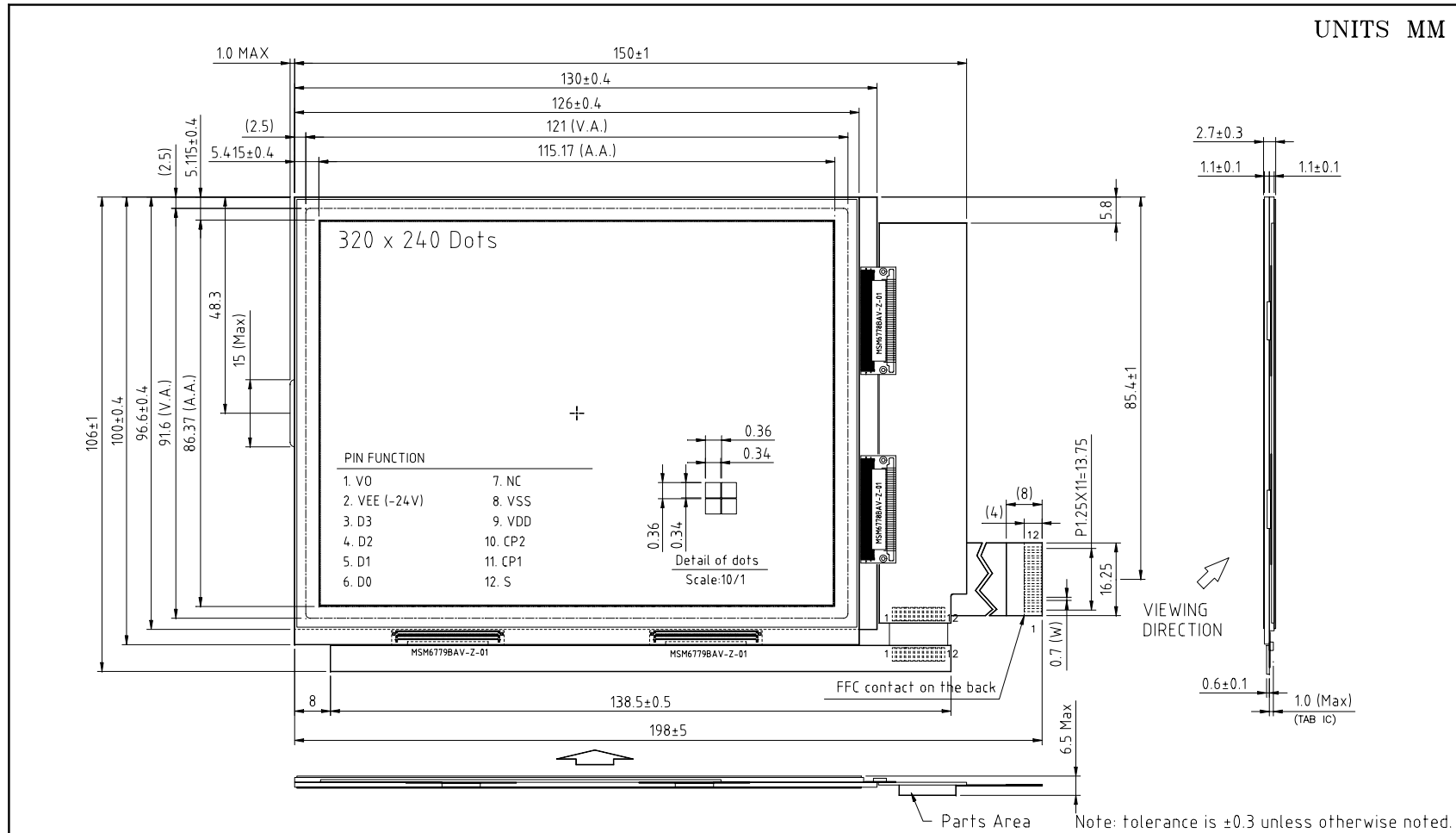

				DATE:	11/30/00	DATA IMAGE	
				DRAWN:		Corporation	
				CHECK:		TITLE: LCM OUTLINE DIMENSION	
				APPROVE:		ISSUE DATE: 2/18/03'	
△	Cgange part NO. TG32242 to dwg NO. TG322400	DATE	APPROVED	A4		DWG. NO. TG322400	REV. B
REVISIONS				SCALE : 5/6		SHEET 1 OF 1	

16. PACKAGE INFORMATION

