

DATA IMAGE CORPORATION

LCD Module Specification

ITEM NO.: **TG322430FFEBB-01**

Table of Contents

1. COVER & CONTENTS	1
2. RECORD OF REVISION	2
3. GENERAL SPECIFICATIONS	3
4. ABSOLUTE MAXIMUM RATINGS	4
5. ELECTRICAL CHARACTERISTICS	5
6. ELECTRO-OPTICAL CHARACTERISTIC	5
7. TIMING CHARACTERISTICS	8
8. PIN CONNECTIONS	14
9. POWER SUPPLY	14
10. BLOCK DIAGRAM	15
11. QUALITY ASSURANCE	17
12. LOT NUMBERING SYSTEM	21
13. LCM NUMBERING SYSTEM	21
14. PRECAUTIONS IN USE LCM	22
15. OUTLINE DRAWING	23
16. PACKAGE INFORMATION.....	24

R&D Dept.	Q.C. Dept.	Eng. Dept.	Prod. Dept.
Version:	Issued Date:	Sheet Code:	Total Pages:
B	2003/3/31		24

2. RECORD OF REVISION

Rev	Date	Item	Page	Comment
B	31/MAR/03	5,7.1,9,10	5,11,14-15	Modify 1. ELECTRICAL CHARACTERISTICS 2. ELECTRO-OPTICAL CHARACTERISTIC 3. TIMING CHART 4. POWER SUPPLY 5. BLOCK DIAGRAM

3. GENERAL SPECIFICATION

Display Format : 320 (W) × 240 (H) dots
Dots Size : 0.225 (W) × 0.225 (H) mm
View Area : 80.3 (W) × 61.8 (H) mm
General Dimensions : 89.0 (W) × 70.45 (H) × 10.0 (T) mm Max.

Weight : 50 g max.

LCD Type : STN Blue STN Yellow FSTN

Polarizer mode : Reflective Transflective

Transmissive Negative

View Angle : 6 O'clock 12 O'clock Others _____

Backlight : LED EL CCFL

Backlight Color : Yellow green Amber Blue Green

White Others

Controller / Driver : NT7701/NT7702

Temperature Range : Normal Wide Temperature
Operating 0 to 50°C Operating -20 to 70°C
Storage -20 to 70°C Storage -30 to 80°C

4. ABSOLUTE MAXIMUM RATINGS

4.1 ELECTRICAL ABSOLUTE MAXIMUM RATINGS

$V_{SS} = 0V$, $T_a = 25^{\circ}C$

Item	Symbol	Min.	Max.	Unit
Supply Voltage (Logic)	VDD-VSS	0	7.0	V
Supply Voltage (LCD Driver)	VLCD-VSS	0	24	V
Operating Temperature	TOP	-20	70	$^{\circ}C$
Storage Temperature	TSTG	-30	80	$^{\circ}C$

4.2 ENVIRONMENTAL ABSOLUTE MAXIMUM RATINGS

Item	Operating		Storage		Comment
	(Min.)	(Max.)	(Min.)	(Max.)	
Ambient Temp	-20	70	-30	80	Note (1)
Humidity	Note (2)		Note(2)		Without Condensation
Vibration	--	4.9M/S ²	--	19.6M/S ²	XYZ Direction
Shock	--	29.4M/S ²	--	490M/S ²	XYZ Direction

Note(1) $T_a = 0^{\circ}C$: 50Hr Max.

Note(2) $T_a \leq 40^{\circ}C$: 90% RH Max.

$T_a \geq 40^{\circ}C$: Absolute humidity must be lower than the humidity of 90% RH at $40^{\circ}C$.

5. ELECTRICAL CHARACTERISTICS

Item	Symbol	Condition	Min.	Typ.	Max.	Unit
Supply Voltage (Logic)	VDD-VSS		2.5	3.3	5.5	V
Supply Voltage (LCD)	VLCD	-20°C	23	23.5	23.9	V
		25°C	20.4	21.2	21.9	
		70°C	19.7	20.1	20.8	
Input Voltage	V _{IH}	--	0.8*VDD	--	VDD	V
	V _{IL}		VSS	--	0.2*VDD	
Logic Supply Current	I _{DD}	LCD-ON	--	10.5	--	mA
		LCD-OFF	--	0.08	--	
	I _{EL}	IF EL B/L=ON	--	25.4	--	
		IF EL B/L=OFF	--	0.02	--	

6. ELECTRO-OPTICAL CHARACTERISTICS

ITEM	Symbol	Condition	Min.	Typ.	Max.	Unit	Ref.
Rise Time	Tr	0°C	--	--	--	ms	Note (1)
		25°C		260	520		
Fall Time	Tf	0°C	--	--	--	ms	
		25°C		310	620		
Contrast	CR	25°C	2	6			Note (3)
View Angle	θ _{1~θ2} ∅ _{1, ∅2}	25°C & CR≥2	60	--	--		Note (2)
			90	--	--		
Frame Frequency	Ff	25°C	--	70	--	Hz	

Note (1) & (2) : See next page

Note (3) : Contrast ration is defined under the following condition:

$$CR = \frac{\text{Brightness of non-selected condition}}{\text{Brightness of selected condition}}$$

- (a). Temperature ----- 25°C
- (b). Frame frequency ---- 70Hz
- (c). Viewing angle ----- θ= 0°, ∅ = 0°
- (d). Operating voltage --- 21.2

Note (1) Response time is measured as the shortest period of time possible between the change in state of an LCD segment as demonstrated below:

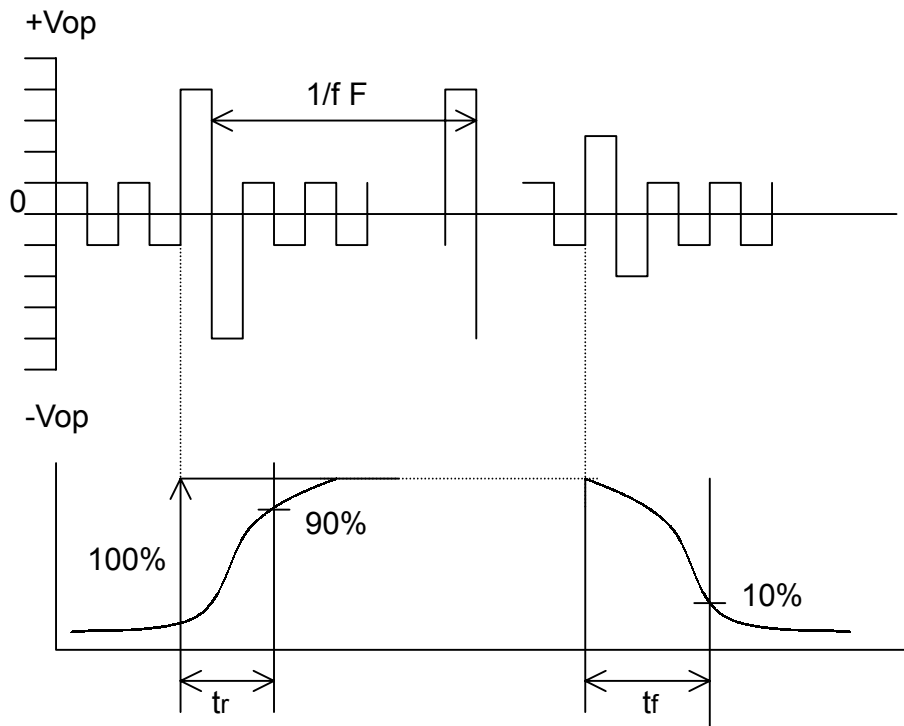

Condition:

- (a) . Temperature ----- $25^{\circ}C$
- (b) . Frame frequency ----- 70Hz
- (c) . View Angle ----- $\theta = 0^{\circ}$, $\phi = 0^{\circ}$
- (d) . Operating voltage ----- 21.2V

Note (2) Definition of View Angle

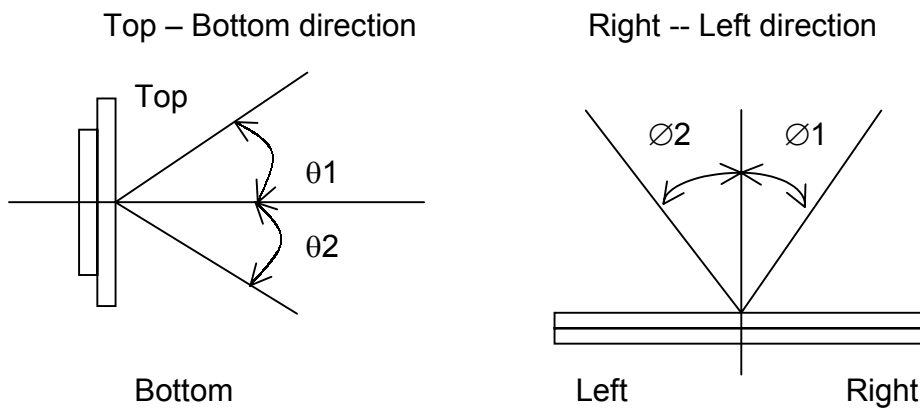

6.1 ELECTRIC - OPTICAL CHARACTERISTIC

(TEMP : 20°C)

ITEM	CONDITION	DIMENION		STANDARD		
				MIN	TYP	MAX
BRIGHTNESS	400Hz,100Vrms SINE WAVE	cd/m ²		45	56	--
UNIFORMITY	400Hz,100Vrms SINE WAVE	%		85	90	--
CURRENT CONSUMPTION	400Hz,100Vrms SINE WAVE	mA/cm ²		--	0.12	0.17
CHROMATICITY	400Hz,100Vrms SINE WAVE	BLUE GREEN	X	0.15	0.17	0.19
			Y	0.33	0.35	0.37
		White	X	0.30	0.32	0.34
			Y	0.34	0.36	0.38

Note: Measured at the EL panel unit.

7. TIMING CHARACTERISTICS

Segment timing:

Item	Symbol	Condition	Min.	Typ.	Max.	Units
Shift Clock Period *1	T _{WCK}	T _R , T _F ≤ 10ns	125			ns
Shift Clock Pulse Width	T _{WCKH} T _{WCKL}		51			ns
Data Set Up Time	T _{DS}		30			ns
Data Hold Time	T _{DH}		40			ns
Latch Pulse “H” Pulse Width	T _{WLPH}		51			ns
Shift Clock Rise to Latch Pulse Rise Time	T _{LD}		0			ns
Shift Clock Fall to Latch Pulse Fall Time	T _{SL}		51			ns
Latch Pulse Rise to Shift Clock Rise Time	T _{LS}		51			ns
Latch Pulse Fall to Shift Clock Fall Time	T _{LH}		51			ns
Input Signal Rise/ Fall Time *2	T _R , T _F				50	ns
Enable Setup Time	T _S		36			ns
DISPOFFB Removal Time	T _{SD}		100			ns
DISPOFFB “L” Pulse Width	T _{WDL}		1.2			u
Output Delay Time (1)	T _D	C _L = 15pF			78	ns
Output Delay Time (2)	T _{PD1} , T _{PD2}	C _L = 15pF			1.2	us
Output Delay Time (3)	T _{PD3}	C _L = 15pF			1.2	us

Note: *1. Take the cascade connection into consideration.

*2. $(T_{WCK} - T_{WCKH} - T_{WCKL})/2$ is maximum in the case of high speed operation.

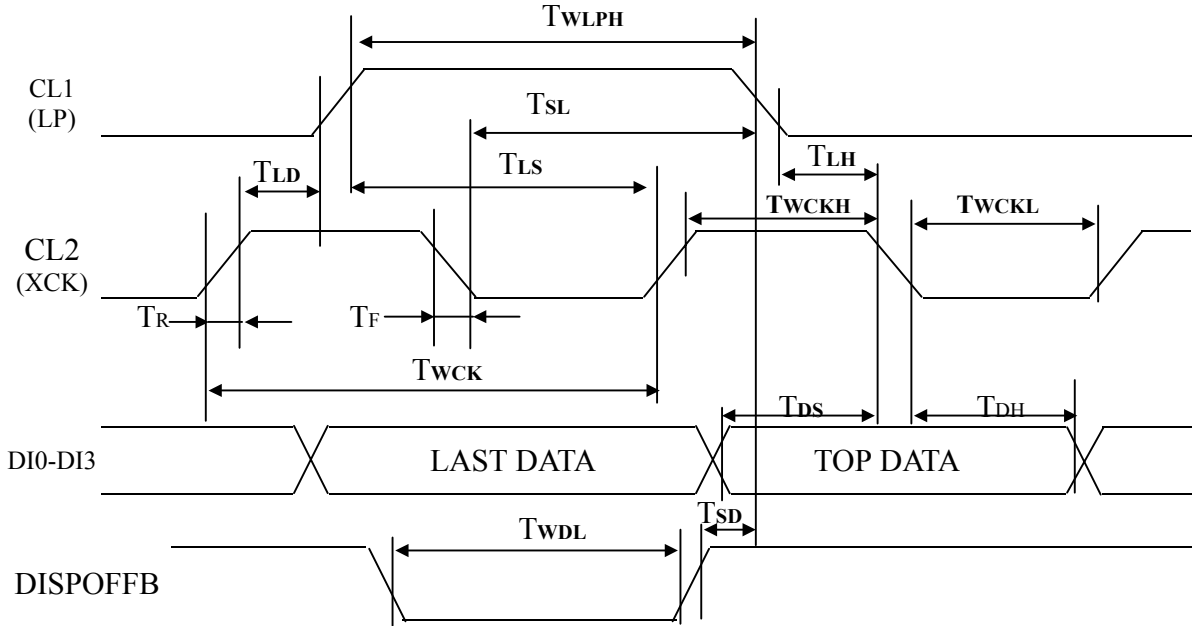

SEGMENT TIMING

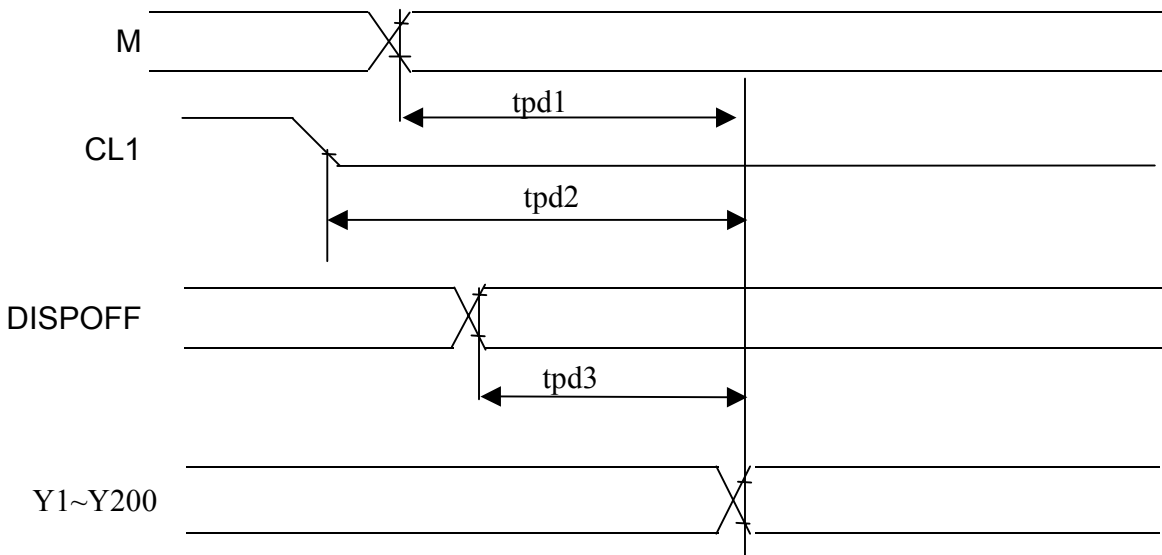

common timing:

Item	Symbol	Condition	Min.	Typ.	Max.	Units
Shift Clock Period	T _{WLP}	T _R , T _F ≤ 20ns	250			ns
Pulse “H” Pulse Width	T _{WLPH}	V _{DD} = +5.0V ± 10%	15			ns
		V _{DD} = +2.5V ~ +4.5V	30			
Data Set Up Time	T _{SU}		30			ns
Data Hold Time	T _H		50			ns
Input Signal Rise/ Fall Time	T _R , T _F				50	ns
DISPOFFB Removal Time	T _{SD}		100			ns
DISPOFFB “L” Pulse Width	T _{WDL}		1.2			u
Output Delay Time (1)	T _{D1}	CL = 15pF			200	ns
Output Delay Time (2)	T _{PD1} , T _{PD2}	CL = 15pF			1.2	us
Output Delay Time (3)	T _{PD3}	CL = 15pF			1.2	us

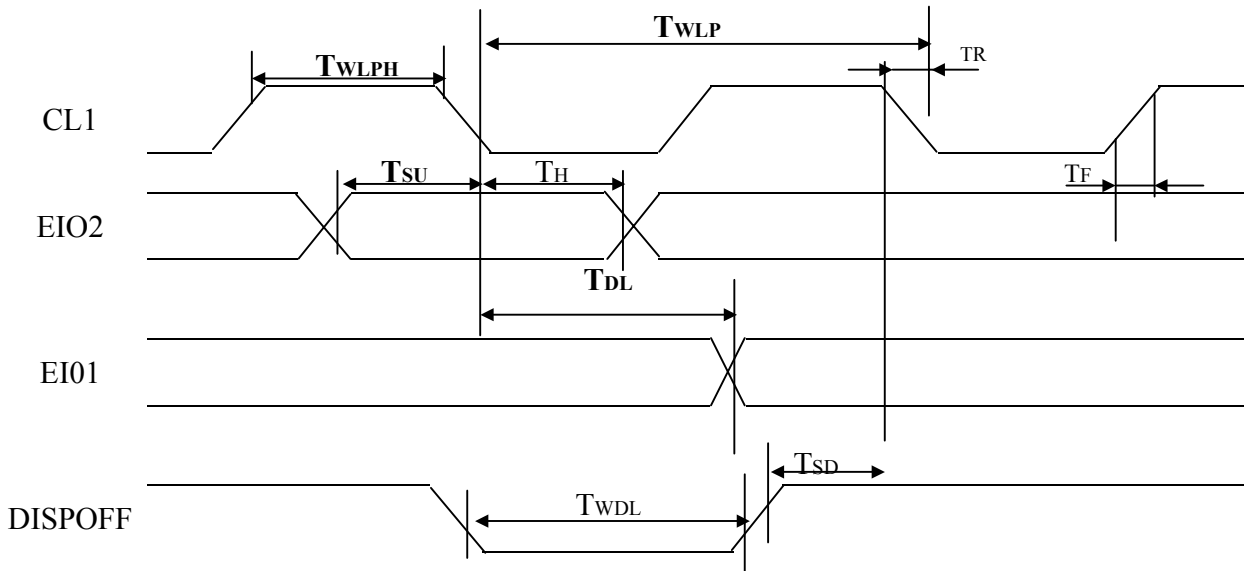

COMMON TIMING

7.1 TIMING CHART

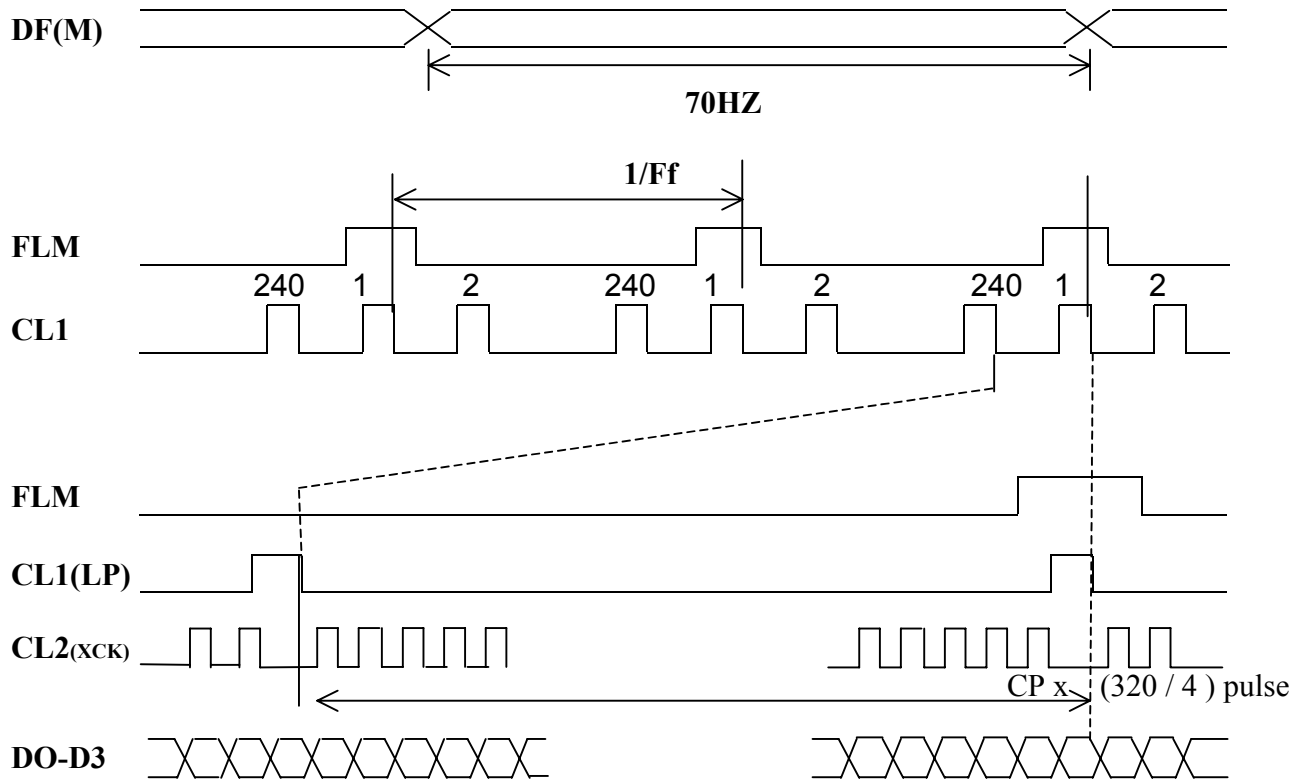

7.3 S-8330 Timing

common timing:

Item	Symbol	Condition	Min.	Typ.	Max.	Units
Output Voltage range	VOUT	S-8330A24	12	-	24	V
Potential division accuracy			-	-	±2.4	%
Electric volume resolution			-	1/256	-	
Error in linearity			-	-	±1/2	LSB
Data setup time	tsc		0.5	-	-	µs
Data hold time	thc		0.5	-	-	µs
VCLK falling edge to VSTRB rising edge	tss		0.5	-	-	µs
VSTRB pulse width	tda		0.5	-	-	µs
VSTRB falling edge to VCLK rising edge	ths		0.5	-	-	µs
VCLK pulse width	tdc		0.5	4.17	-	µs
VCLK period	ttc		5	8.33	-	µs
VDIN, VCLK, VSTRB input voltage "H" level	VSHC1	$V_{IN} \geq 3.0V$	2.4	-	-	V
	VSHC2	$V_{IN} \leq 3.0V$	1.6	-	-	
VDIN, VCLK, VSTRB input voltage "L" level	VSLC		-	-	0.2	
VDIN, VCLK, VSTRB input leakage current	ISLC	$V_{IN} = 9V$	-1	-	1	µA

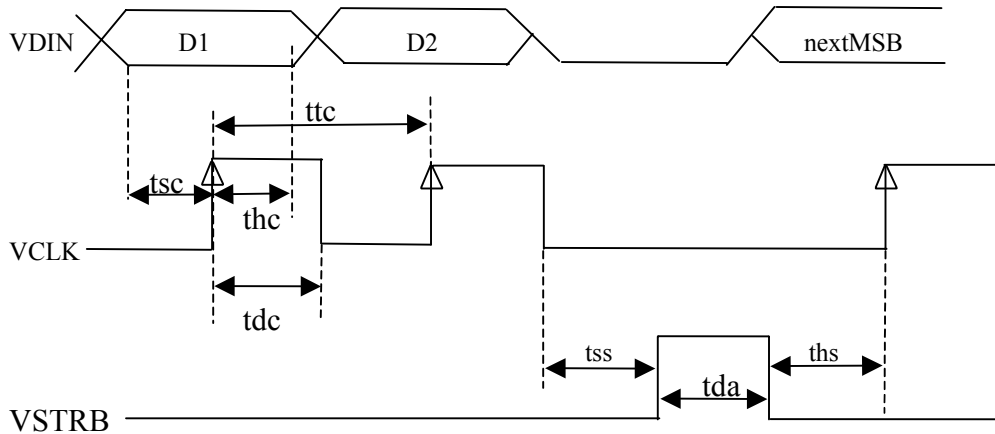

Data input Timing

Note 1: An electric volume has 8-bit resolution. However, its error in linearity may exceed ±1/2LSB only before and after switching from 127 to 128 (from 01111111 to 10000000) and vice versa. When the electric volume is used within the variable range of 12 V, its error in linearity corresponds to 6 bits (±2.4% potential division accuracy is ensured).

Electric Volume

The S-8330/31 series incorporates an electric volume with an 8-bit shift register and an 8-bit latch. The output voltage is variable in the width of 12V. The output voltage can be held in the data transmission mode because the data read in the shift register is fetched into the latch by unshynchronized strobe input. Figure 1 shows a block diagram and timing charts

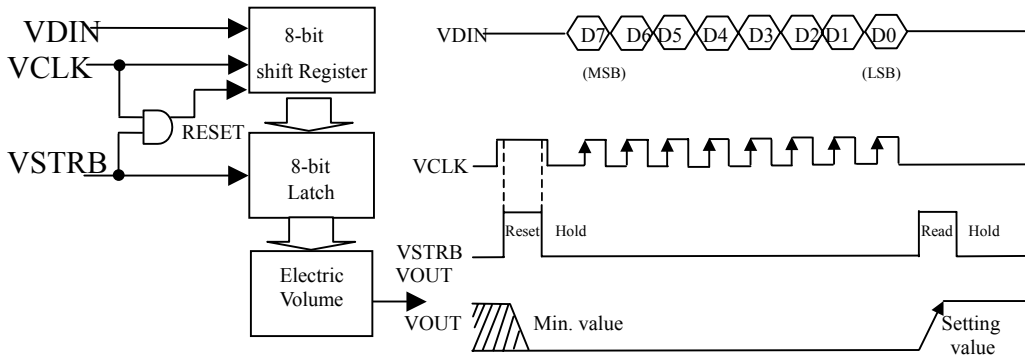

Figure 1 Block Diagram and Timing

VDIN :Inputs data to the electric volume. “Data 1” is input at “H” level; “Data 0” is input at “LOW” level.

VCLK :Inputs clock to the electric volume. Fetches data at VDIN pin into the shift register at the rising edge of clocks. When clocks of over 8 bits are input, the read data is shifted in succession for each clock, and data corresponding to 8 bits which was input lastly is valid.

VSTRB :Inputs strobe signal. The contents of the shift register are latched by turning the strobe signal to “H”. When the data fetched into the latch is directly transmitted to the electric volume, the output voltage changes. Data in the latch is held by turning the strobe signal to “L”.

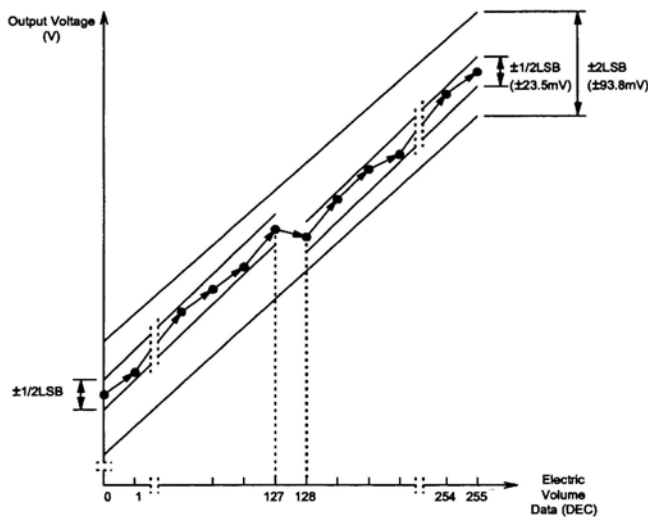

Figure 9 Linearity Accuracy

The electric volume has 8-bit resolution. An error in linearity may exceed $\pm 1/2LSB$ (± 23.5 mV) only before or after data changeover of 127 to 128 (01111111 to 10000000) (see Figure 9).

The error in linearity corresponds to 6 bits (± 93.8 mV) when used in the 12 V variable range.

In an application where the variable range of output voltage is 6 V or less, it is possible to use it with high linearity accuracy with appropriate product selection. For example, if you want to change output voltage within the range from 12 V to 18 V, select the S-8330A24FS and use it within the range of 0 to 127 (00000000 to 01111111). If so, high linearity accuracy (within $\pm 1/2LSB$) can be obtained.

8. PIN CONNECTIONS

No.	Symbol	Function
1	VDIN	Electric Volume data input pin.
2	VCLK	Electric Volume clock input pin..
3	VSTRB	Electric Volume strobe signal input pin..
4	VDD	Power Supply for Logic
5	FLM	First line mark.
6	VSS	Ground, 0V
7	CL1	Data latch pulse.
8	VSS	Ground, 0V
9	M	Switch signal to convert LCD drive wave form into AC
10	/D-OFF	Display ON/ OFF control input (“H”=ON, “L”=OFF)
11	CL2	Data shift pulse.
12	NC	NO Connection.
13	NC	NO Connection.
14	D3	Input data signal 3.
15	D2	Input data signal 2.
16	D1	Input data signal 1.
17	D0	Input data signal 0.
18	N.C	NO Connection.
19	N.C	NO Connection.
20	N.C	NO Connection.
21	N.C	NO Connection.
22	N.C	NO Connection.
23	EL-VCC	Back light Power Supply for EL(+3.3V)
24	/EL-ON	EL Back light ON/OFF (“H”= OFF, “L”= ON)

9. POWER SUPPLY

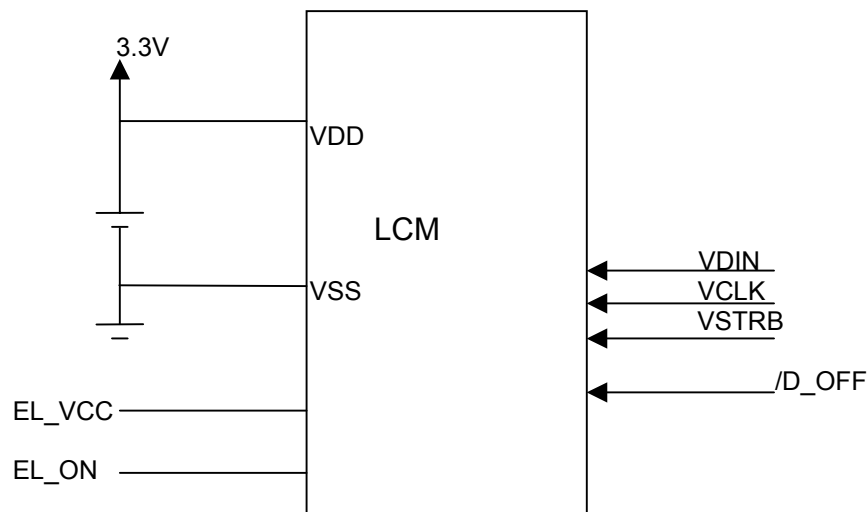

10. BLOCK DIAGRAM

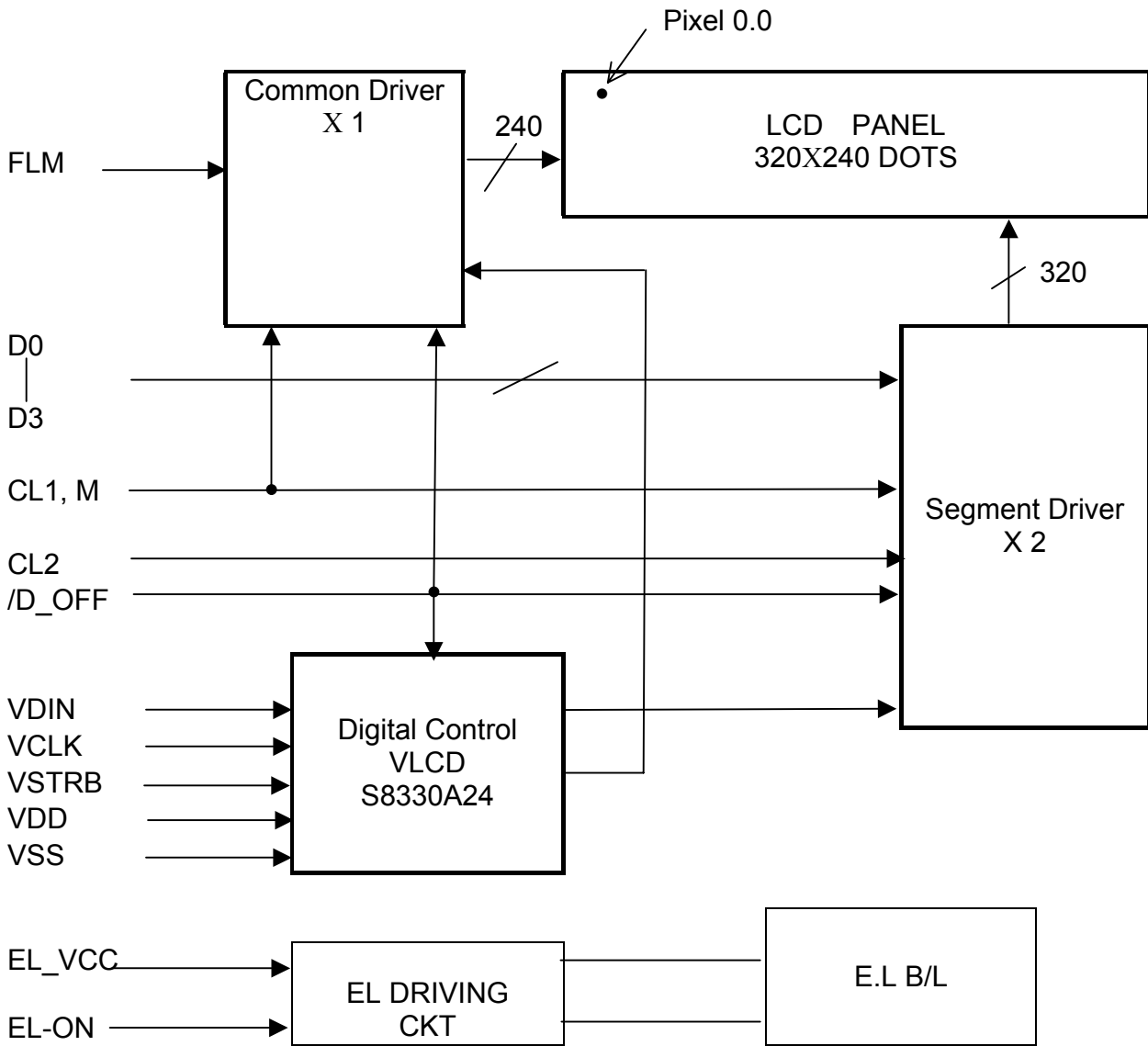

10.1 DISPLAY PATTERN

FIRST DATA



COM001	D3	D2	D1	D0	D3	D2	D1	D0	
COM002	D3	D2	D1	D0	D3	D2	D1	D0	
COM239	D3	D2	D1	D0	D3	D2	D1	D0	
COM240	D3	D2	D1	D0	D3	D2	D1	D0	
	SEG001	SEG002				SEG319	SEG320		

320*240 Dots Matrix

11. QUALITY ASSURANCE

11.1 Test Condition

11.1.1 Temperature and Humidity(Ambient Temperature)

Temperature : $20 \pm 5^{\circ}\text{C}$

Humidity : $65 \pm 5\%$

11.1.2 Operation

Unless specified otherwise, test will be conducted with LCM in operation.

11.1.3 Container

Unless specified otherwise, vibration test will be conducted on module only.

11.1.4 Test Frequency

Single cycle.

11.1.5 Test Method

No.	Parameter	Conditions	Regulations
1	High Temperature Operating	$70 \pm 2^{\circ}\text{C}$	Note 3
2	Low Temperature Operating	$-20 \pm 2^{\circ}\text{C}$	Note 3
3	High Temperature Storage	$80 \pm 2^{\circ}\text{C}$	Note 3
4	Low Temperature Storage	$-30 \pm 2^{\circ}\text{C}$	Note 3
5	Vibration Test (Non-operation state)	Total fixed amplitude : 1.5mm Vibration Frequency : 10 ~ 55Hz One cycle 60 seconds to 3 directions of X.Y.Z. for each 15 minutes	Note 3
6	Damp Proof Test (Non-operation state)	$40^{\circ}\text{C} \pm 2^{\circ}\text{C}$, 90~95%RH, 96h	Note 1,2
7	Shock Test (Non-operation state)	To be measured after dropping from 60cm high once concrete surface in packing state	Note 3

Note 1: Returned under normal temperature and humidity for 4 hrs.

Note 2: No dew condensation to be observed.

Note 3: No change on display and in operation under the test condition

11.2 Inspection condition

11.2.1 Inspection conditions

The LCD shall be inspected under 40W white fluorescent light.

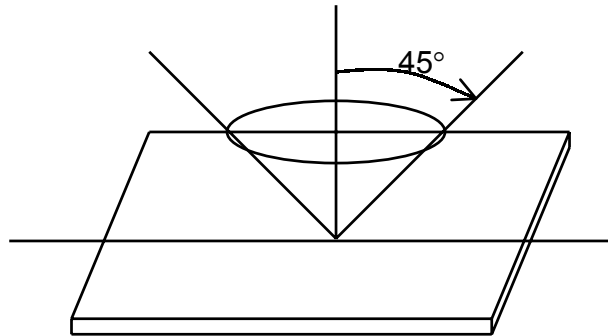

11.2.2 Definition of applicable Zones

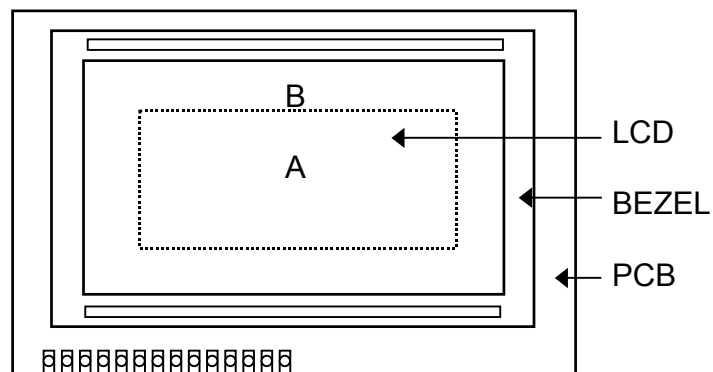

A : Display Area
B : Non-Display Area

11.2.3 Inspection Parameters

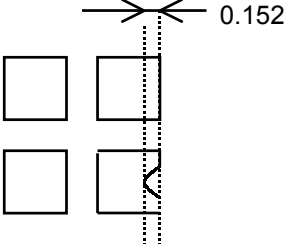
No.	Parameter	Criteria																												
1	Black or White spots	<table border="1"> <thead> <tr> <th rowspan="2">Zone Dimension</th> <th colspan="2">Acceptable number</th> <th rowspan="2">Class Of Defects</th> <th rowspan="2">AQL Level</th> </tr> <tr> <th>A</th> <th>B</th> </tr> </thead> <tbody> <tr> <td>D < 0.15</td> <td>*</td> <td>*</td> <td rowspan="4">Minor</td> <td rowspan="4">2.5</td> </tr> <tr> <td>0.15 ≤ D < 0.2</td> <td>4</td> <td>4</td> </tr> <tr> <td>0.2 ≤ D ≤ 0.25</td> <td>2</td> <td>2</td> </tr> <tr> <td>D ≤ 0.3</td> <td>0</td> <td>1</td> </tr> </tbody> </table> <p style="text-align: center;">D = (Long + Short) / 2 * : Disregard</p>	Zone Dimension	Acceptable number		Class Of Defects	AQL Level	A	B	D < 0.15	*	*	Minor	2.5	0.15 ≤ D < 0.2	4	4	0.2 ≤ D ≤ 0.25	2	2	D ≤ 0.3	0	1							
Zone Dimension	Acceptable number			Class Of Defects	AQL Level																									
	A	B																												
D < 0.15	*	*	Minor	2.5																										
0.15 ≤ D < 0.2	4	4																												
0.2 ≤ D ≤ 0.25	2	2																												
D ≤ 0.3	0	1																												
2	Scratch, Substances	<table border="1"> <thead> <tr> <th colspan="2">Zone</th> <th colspan="2">Acceptable number</th> <th rowspan="2">Class Of Defects</th> <th rowspan="2">AQL Level</th> </tr> <tr> <th>X (mm)</th> <th>Y(mm)</th> <th>A</th> <th>B</th> </tr> </thead> <tbody> <tr> <td>*</td> <td>0.04 ≥ W</td> <td>*</td> <td>*</td> <td rowspan="4">Minor</td> <td rowspan="4">2.5</td> </tr> <tr> <td>3.0 ≥ L</td> <td>0.06 ≥ W</td> <td>4</td> <td>4</td> </tr> <tr> <td>2.0 ≥ L</td> <td>0.08 ≥ W</td> <td>2</td> <td>3</td> </tr> <tr> <td>—</td> <td>0.1 < W</td> <td>0</td> <td>1</td> </tr> </tbody> </table> <p style="text-align: center;">X : Length Y : Width * : Disregard Total defects should not exceed 4/module</p>	Zone		Acceptable number		Class Of Defects	AQL Level	X (mm)	Y(mm)	A	B	*	0.04 ≥ W	*	*	Minor	2.5	3.0 ≥ L	0.06 ≥ W	4	4	2.0 ≥ L	0.08 ≥ W	2	3	—	0.1 < W	0	1
Zone		Acceptable number		Class Of Defects	AQL Level																									
X (mm)	Y(mm)	A	B																											
*	0.04 ≥ W	*	*	Minor	2.5																									
3.0 ≥ L	0.06 ≥ W	4	4																											
2.0 ≥ L	0.08 ≥ W	2	3																											
—	0.1 < W	0	1																											
3	Air Bubbles (between glass & polarizer)	<table border="1"> <thead> <tr> <th rowspan="2">Zone Dimension</th> <th colspan="2">Acceptable number</th> <th rowspan="2">Class of Defects</th> <th rowspan="2">AQL Level</th> </tr> <tr> <th>A</th> <th>B</th> </tr> </thead> <tbody> <tr> <td>D ≤ 0.15</td> <td>*</td> <td>*</td> <td rowspan="3">Minor</td> <td rowspan="3">2.5</td> </tr> <tr> <td>0.15 < D ≤ 0.25</td> <td>2</td> <td>*</td> </tr> <tr> <td>0.25 < D</td> <td>0</td> <td>1</td> </tr> </tbody> </table> <p style="text-align: center;">* : Disregard Total defects shall not excess 3/module.</p>	Zone Dimension	Acceptable number		Class of Defects	AQL Level	A	B	D ≤ 0.15	*	*	Minor	2.5	0.15 < D ≤ 0.25	2	*	0.25 < D	0	1										
Zone Dimension	Acceptable number			Class of Defects	AQL Level																									
	A	B																												
D ≤ 0.15	*	*	Minor	2.5																										
0.15 < D ≤ 0.25	2	*																												
0.25 < D	0	1																												
4	Uniformity of Pixel	<p>(1) Pixel shape (with Dent)</p> 																												

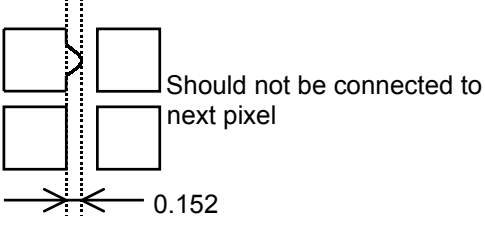
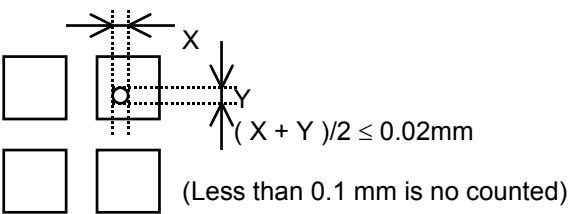
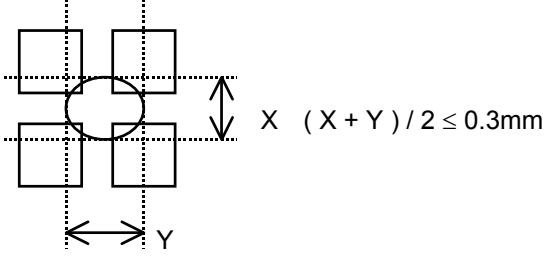
4	Uniformity of Pixel	<p>(2) Pixel shape (with Projection)</p> 	
		<p>(3) Pin hole</p> 	
		<p>(4) Deformation</p> 	
		<p>Total acceptable number : 1/pixel, 5/cell</p>	
Class of defects	Major	AQL 0.65%	<p>Definition</p> <p>It is a defect that is likely to result in failure or to reduce materially the usability of the product for the intended function.</p>
		AQL 1.00%	<p>It is a defect that is likely to assembly size and not result in functioning problem.</p>
	Minor	AQL 2.5%	<p>It is a defect that will not result in functioning problem with deviation classified.</p>

11.3 Sampling Condition

Unless otherwise agree in written, the sampling inspection shall be applied to the incoming inspection of customer.

Lot size: Quantity of shipment lot per model.

Sampling type: normal inspection, single sampling

Inspection level: Level II

Sampling table: MIL-STD-105E

12. LOT NUMBERING SYSTEM

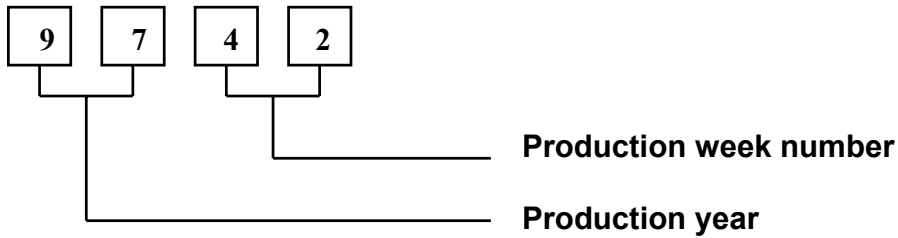

13. LCM NUMBERING SYSTEM

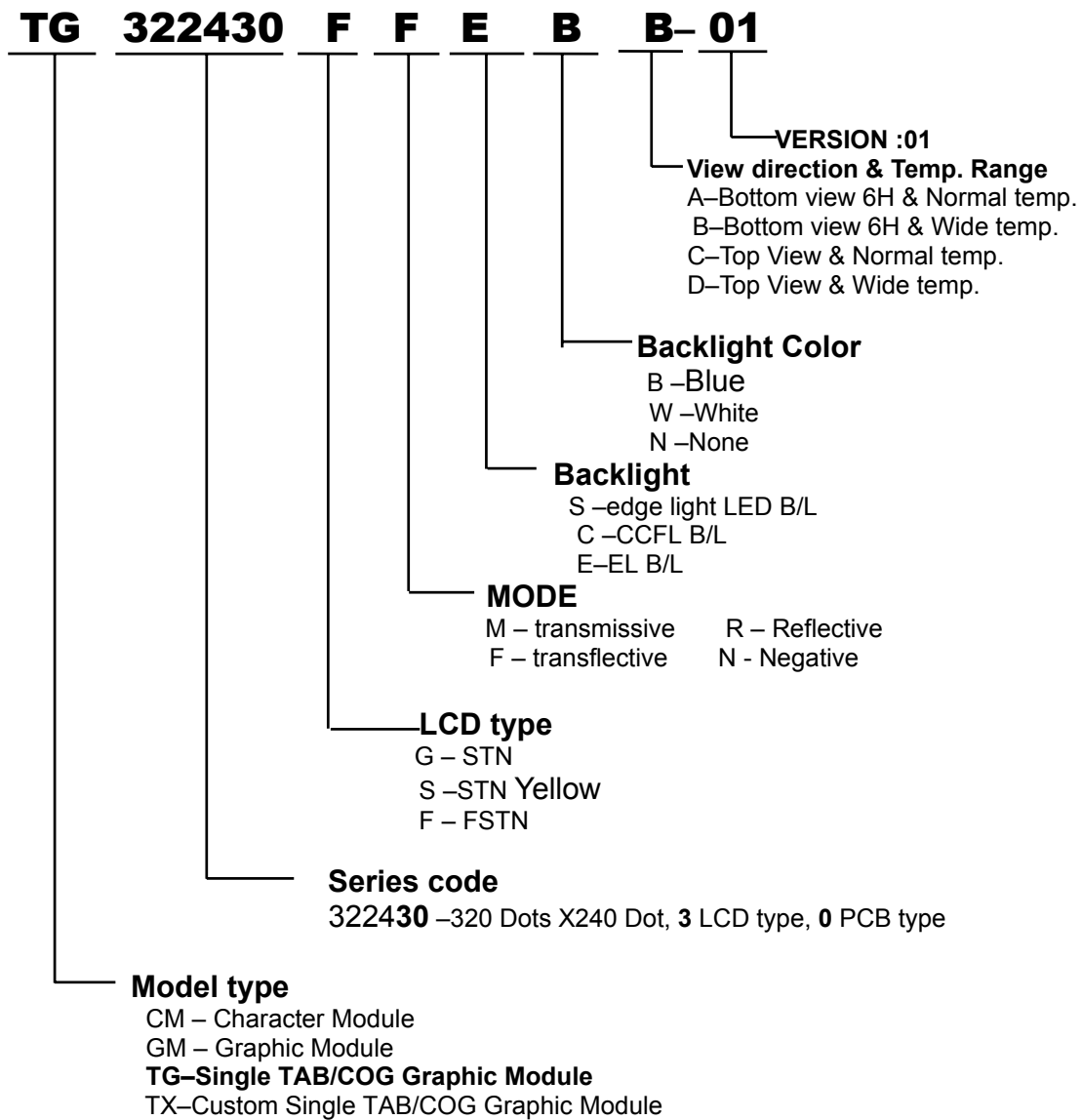

14. PRECAUTION FOR USING LCM

1. LIQUID CRYSTAL DISPLAY (LCD)

LCD is made up of glass, organic sealant, organic fluid, and polymer based polarizers. The following precautions should be taken when handling,

- (1). Keep the temperature within range of use and storage. Excessive temperature and humidity could cause polarization degradation, polarizer peel off or bubble.
- (2). Do not contact the exposed polarizers with anything harder than an HB pencil lead. To clean dust off the display surface, wipe gently with cotton, chamois or other soft material soaked in petroleum benzin.
- (3). Wipe off saliva or water drops immediately. Contact with water over a long period of time may cause polarizer deformation or color fading, while an active LCD with water condensation on its surface will cause corrosion of ITO electrodes.
- (4). Glass can be easily chipped or cracked from rough handling, especially at corners and edges.
- (5). Do not drive LCD with DC voltage.

2. Liquid Crystal Display Modules

2.1 Mechanical Considerations

LCM are assembled and adjusted with a high degree of precision. Avoid excessive shocks and do not make any alterations or modifications. The following should be noted.

- (1). Do not tamper in any way with the tabs on the metal frame.
- (2). Do not modify the PCB by drilling extra holes, changing its outline, moving its components or modifying its pattern.
- (3). Do not touch the elastomer connector, especially insert an backlight panel (for example, EL).
- (4). When mounting a LCM make sure that the PCB is not under any stress such as bending or twisting. Elastomer contacts are very delicate and missing pixels could result from slight dislocation of any of the elements.
- (5). Avoid pressing on the metal bezel, otherwise the elastomer connector could be deformed and lose contact, resulting in missing pixels.

2.2 Static Electricity

LCM contains CMOS LSI's and the same precaution for such devices should apply, namely

- (1). The operator should be grounded whenever he/she comes into contact with the module. Never touch any of the conductive parts such as the LSI pads, the copper leads on the PCB and the interface terminals with any parts of the human body.
- (2). The modules should be kept in antistatic bags or other containers resistant to static for storage.
- (3). Only properly grounded soldering irons should be used.
- (4). If an electric screwdriver is used, it should be well grounded and shielded from commutator sparks.

- (5) The normal static prevention measures should be observed for work clothes and working benches; for the latter conductive (rubber) mat is recommended.
- (6). Since dry air is inductive to static, a relative humidity of 50-60% is recommended.

2.3 Soldering

- (1). Solder only to the I/O terminals.
- (2). Use only soldering irons with proper grounding and no leakage.
- (3). Soldering temperature : $280^{\circ}\text{C} \pm 10^{\circ}\text{C}$
- (4). Soldering time: 3 to 4 sec.
- (5). Use eutectic solder with resin flux fill.
- (6). If flux is used, the LCD surface should be covered to avoid flux spatters. Flux residue should be removed after wards.

2.4 Operation

- (1). The viewing angle can be adjusted by varying the LCD driving voltage V_0 .
- (2). Driving voltage should be kept within specified range; excess voltage shortens display life.
- (3). Response time increases with decrease in temperature.
- (4). Display may turn black or dark blue at temperatures above its operational range; this is (however not pressing on the viewing area) may cause the segments to appear "fractured".
- (5). Mechanical disturbance during operation (such as pressing on the viewing area) may cause the segments to appear "fractured".

2.5 Storage

If any fluid leaks out of a damaged glass cell, wash off any human part that comes into contact with soap and water. Never swallow the fluid. The toxicity is extremely low but caution should be exercised at all the time.

2.6 Limited Warranty

Unless otherwise agreed between DATA IMAGE and customer, DATA IMAGE will replace or repair any of its LCD and LCM which is found to be defective electrically and visually when inspected in accordance with DATA IMAGE acceptance standards, for a period on one year from date of shipment. Confirmation of such date shall be based on freight documents. The warranty liability of DATA IMAGE is limited to repair and/or replacement on the terms set forth above. DATA IMAGE will not responsible for any subsequent or consequential events.

15 OUTLINE DRAWING

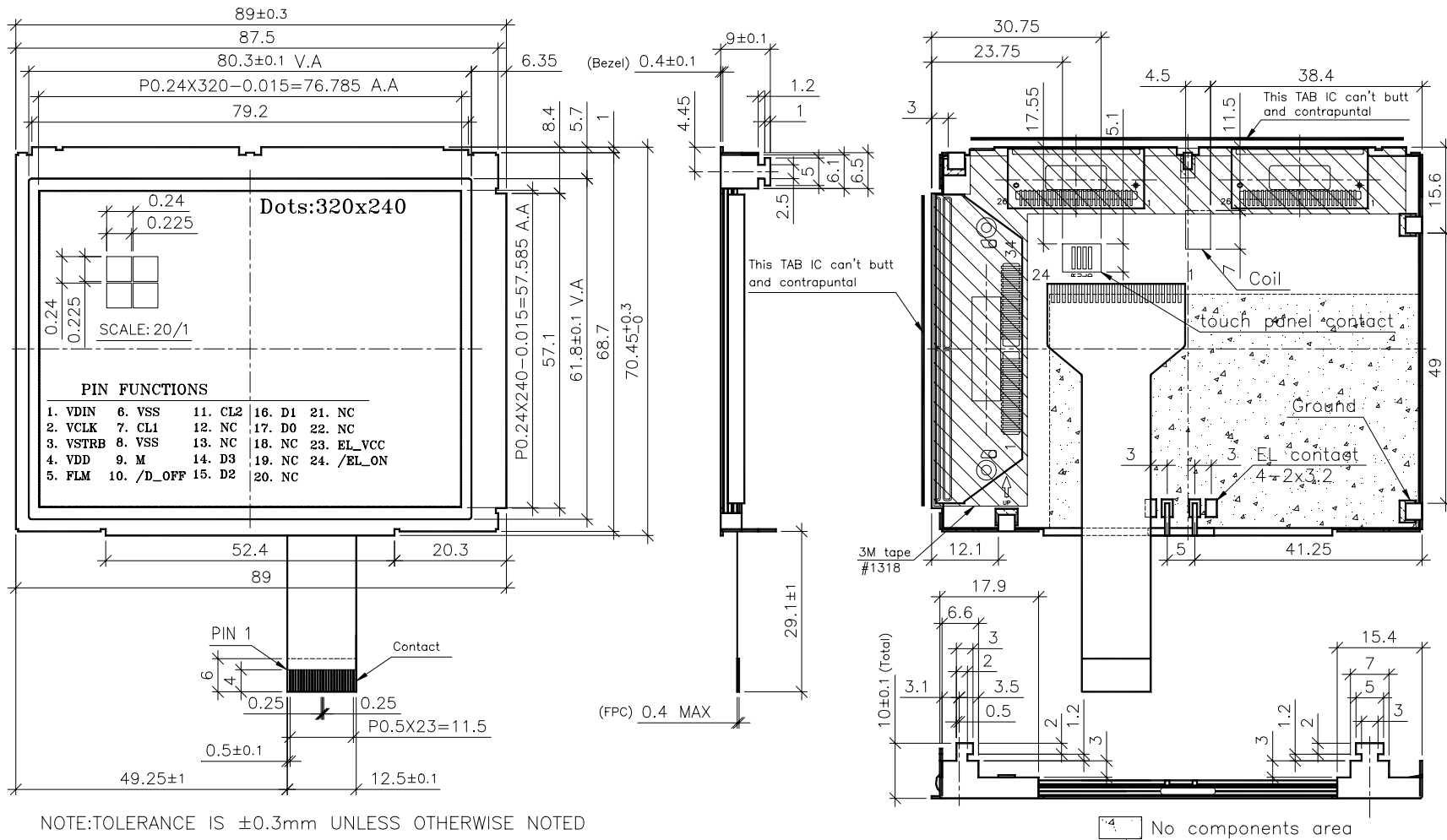

NOTE:TOLERANCE IS ± 0.3 mm UNLESS OTHERWISE NOTED

16. PACKAGE INFORMATION

