

TGA2524-SM

Ku-Band Power Amplifier



Applications

- Point-to-Point Radio
- Ku-band Sat-Com



QFN 3x3 mm 16L

Product Features

- Frequency Range: 11.3 – 16 GHz
- Power: 26.5 dBm Psat, 26 dBm P1dB
- Gain: 23 dB, good gain flatness with regulation
- OTOI: 37 dBm at 8 dBm Pout/tone
- NF: 7 dB
- Bias: Vd = 5 V, Idq = 320 mA, Vg = -0.52 V Typical
- Package Dimensions: 3.0 x 3.0 x 0.85 mm

Functional Block Diagram

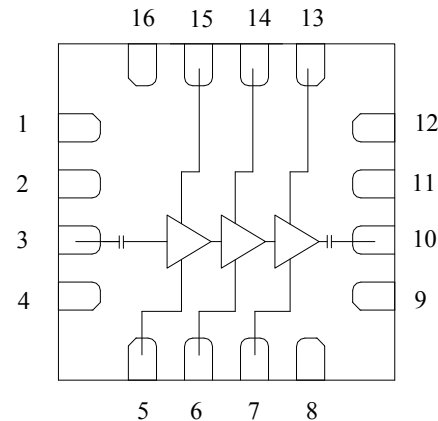

General Description

The TriQuint TGA2524-SM is a Ku-Band Power Amplifier. The TGA2524-SM operates from 11.3 – 16 GHz and is designed using TriQuint’s power pHEMT production process.

The TGA2524-SM typically provides 26.5 dBm of saturated output power with small signal gain of 23 dB.

The TGA2524-SM is available in a low-cost, surface mount 16 lead 3x3 QFN package and is ideally suited for Point-to-Point Radio.

Lead-free and RoHS compliant

Evaluation Boards are available upon request.

Pin Configuration

Pin #	Symbol
1, 2, 4, 8, 9, 11, 12, 16	N/C
3	RF IN
5	Vg1
6	Vg2
7	Vg3
10	RF OUT
13	Vd3
14	Vd2
15	Vd1

Ordering Information

Part No.	ECCN	Description
TGA2524-SM	EAR99	Ku-Band Power Amplifier

Standard T/R size = 500 pieces on a 7” reel.

Specifications

Absolute Maximum Ratings

Parameter	Rating
Drain Voltage, Vd	+8 V
Gate Voltage, Vg	-2 to 0 V
Drain to Gate Voltage, Vd – Vg	12 V
Drain Current, Id	450 mA
Gate Current, Ig	-8.2 to 10 mA
Power Dissipation, P _{diss}	3.6 W
RF Input Power, CW, T = 25°C	19 dBm
Channel Temperature, T _{ch}	200 °C
Mounting Temperature (30 Seconds)	260 °C
Storage Temperature	-40 to 150 °C

Operation of this device outside the parameter ranges given above may cause permanent damage. These are stress ratings only, and functional operation of the device at these conditions is not implied.

Recommended Operating Conditions

Parameter	Min	Typical	Max	Units
Vd		5		V
Idq		320		mA
Id _{drive} (Under RF Drive, Constant Vg)		375		mA
Vg		-0.52		V

Electrical specifications are measured at specified test conditions. Specifications are not guaranteed over all recommended operating conditions.

Electrical Specifications

Test conditions unless otherwise noted: 25°C, Vd = 5 V, Id = 320 mA, Vg = -0.52 V Typical.

Parameter	Min	Typical	Max	Units
Operational Frequency Range	11.3	—	16.0	GHz
Gain 11.3 – 12.0 GHz	17	20		dB
12.0 – 16.0 GHz	20	23		dB
Input Return Loss		-12	-8	dB
Output Return Loss		-15	-10	dB
Output Power @ Saturation <u>1</u> / 11.3 – 12.0 GHz	24.0	25.0		dBm
12.0 – 16.0 GHz	25.5	26.5		dBm
Output Power @ 1dB Gain Compression <u>1</u> / 11.3 – 12.0 GHz	23.5	24.5		dBm
12.0 – 16.0 GHz	25.0	26.0		dBm
Output TOI <u>2</u> / Noise Figure		37		dBm
		7		dB
Gain Temperature Coefficient		-0.035		dB/°C
Power Temperature Coefficient		-0.007		dB/°C

Note 1: Measurements taken with drain current held constant at 320 mA. Saturated output power and P1dB are approximately 1 dB higher when drain current is allowed to increase due to RF input levels (constant gate voltage).

Note 2: Measurements taken at drain current of 300 mA.

Specifications (cont.)

Thermal and Reliability Information

Parameter	Condition	Rating
Thermal Resistance, θ_{JC} , measured to back of package	Tbase = 90 °C	$\theta_{JC} = 31.1$ °C/W
Channel Temperature (Tch), and Median Lifetime (Tm)	Tbase = 90 °C, Vd = 5 V, Id = 320 mA, Pdiss = 1.6 W	Tch = 140 °C Tm = 2.4 E+6 Hours
Channel Temperature (Tch), and Median Lifetime (Tm) Under RF Drive	Tbase = 90 °C, Vd = 5 V, Id = 375 mA, Pout = 26.5 dBm, Pdiss = 1.4 W	Tch = 134 °C Tm = 5.6 E+6 Hours

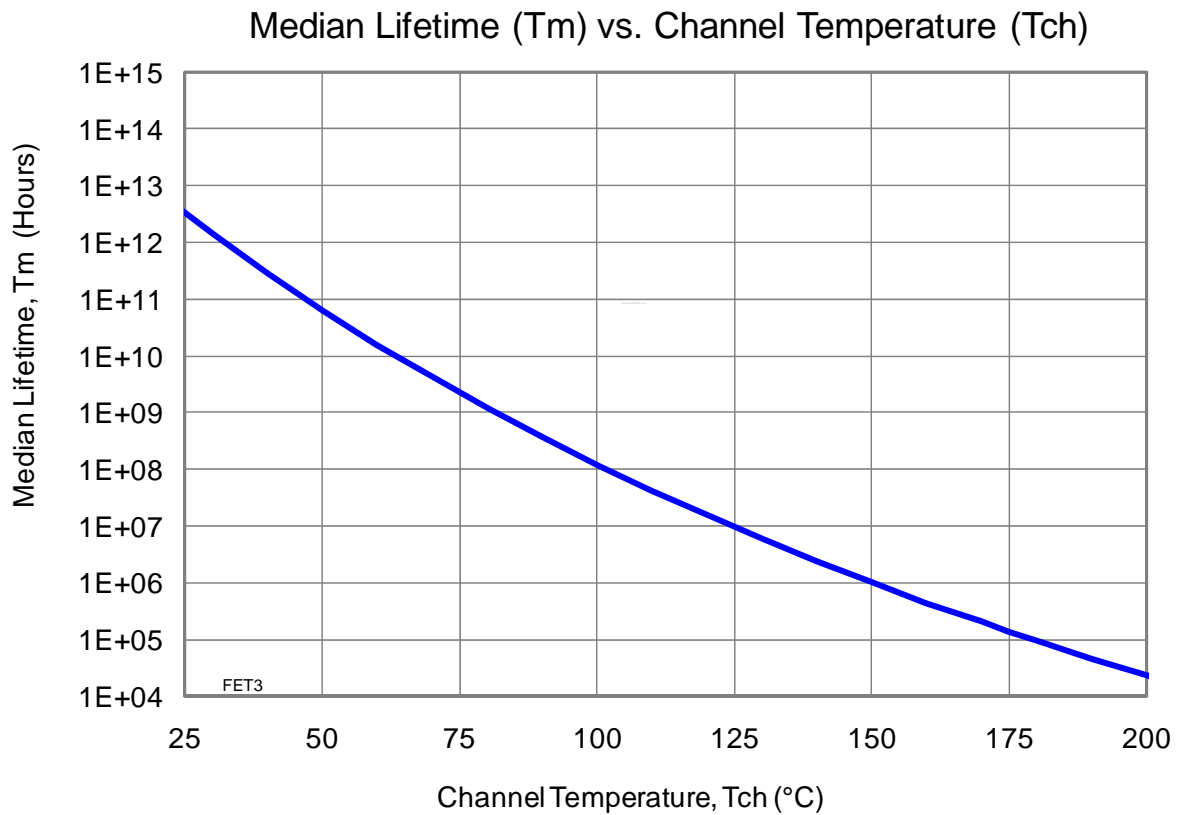

Typical Performance

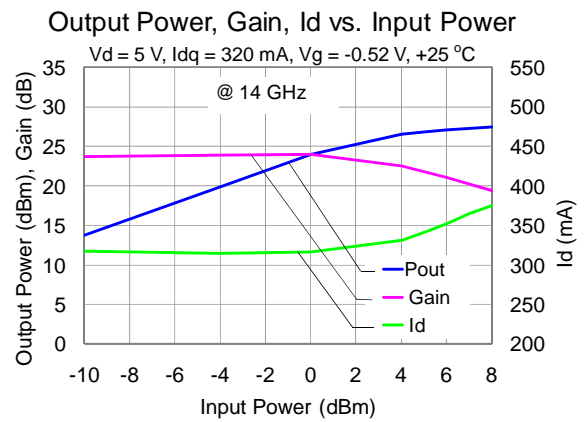
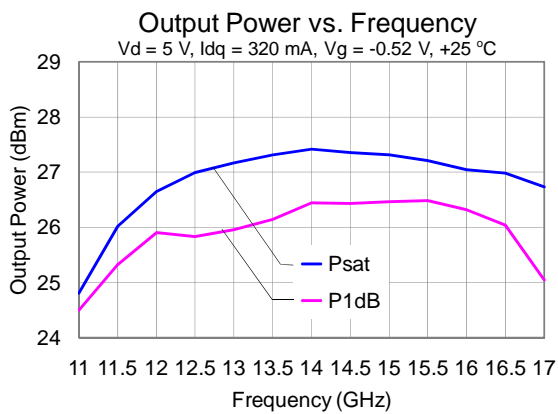
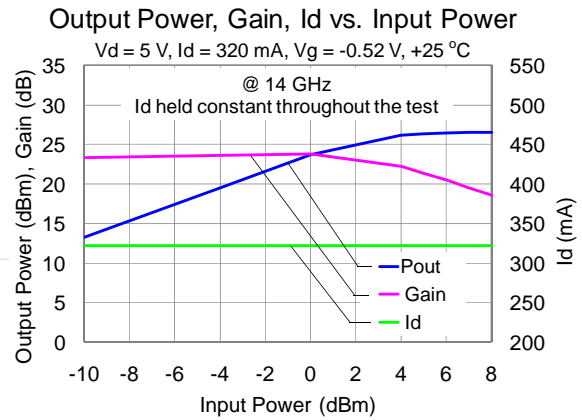
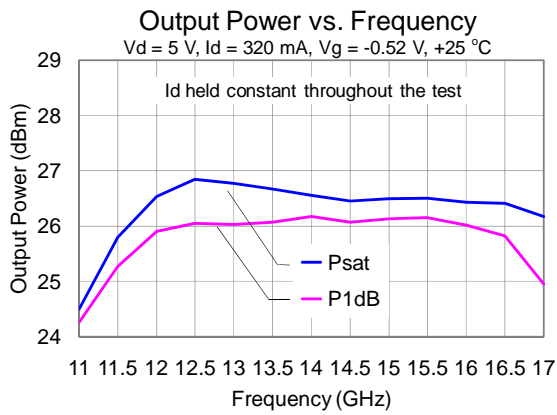
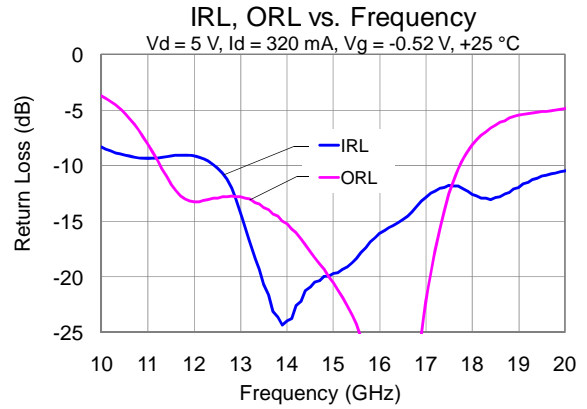
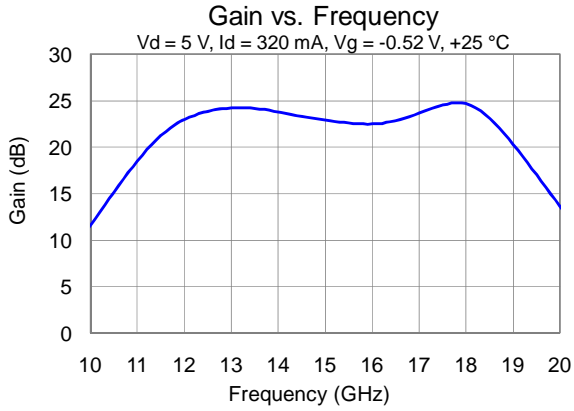

Typical Performance (cont.)

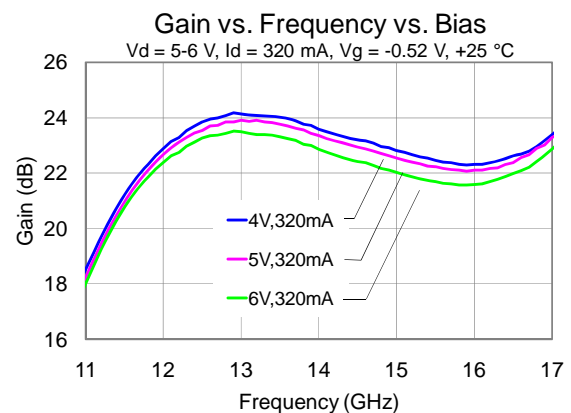
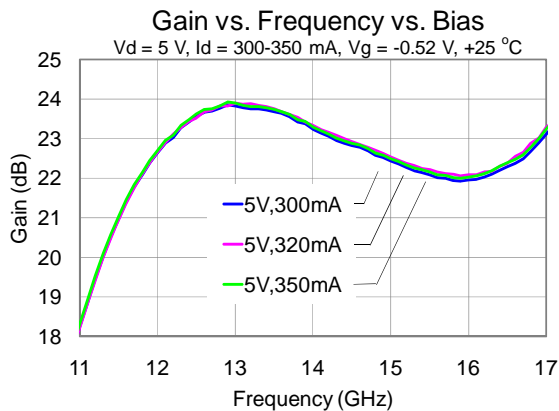
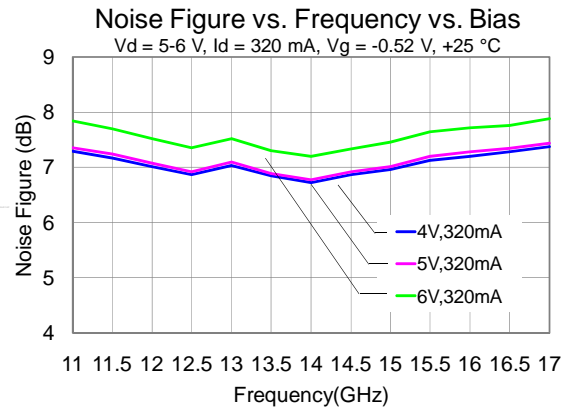
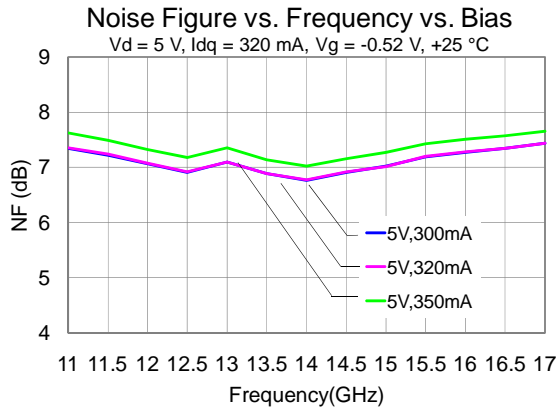
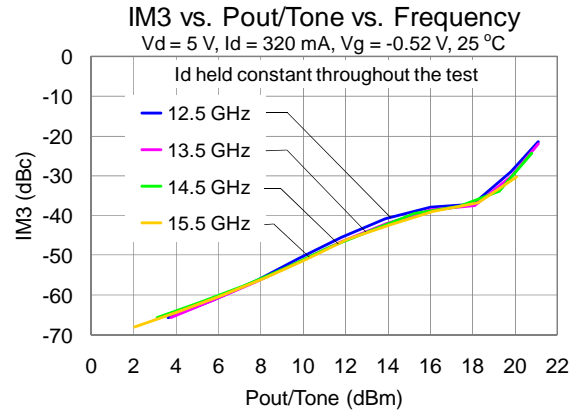
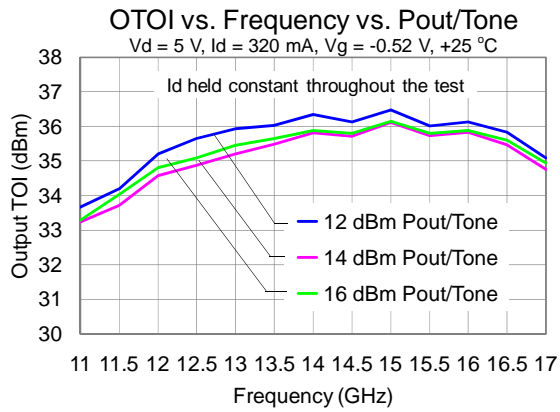

Typical Performance (cont.)

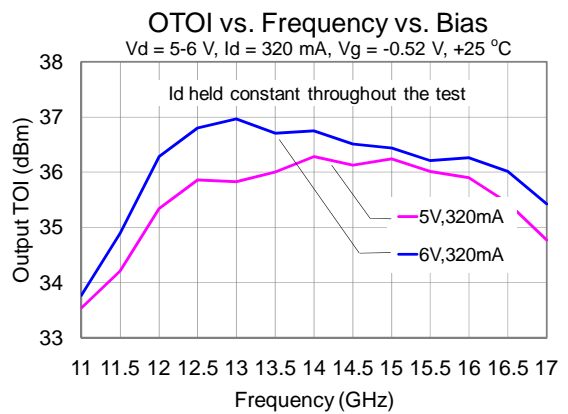
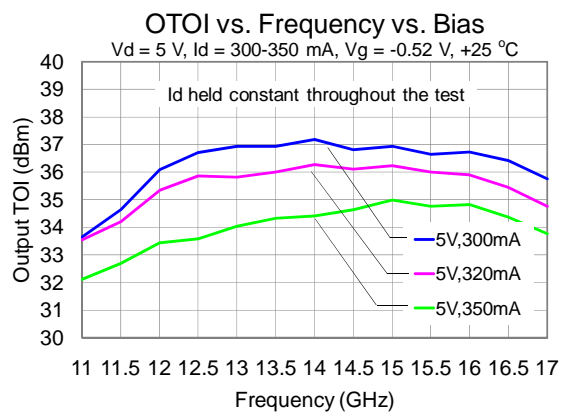
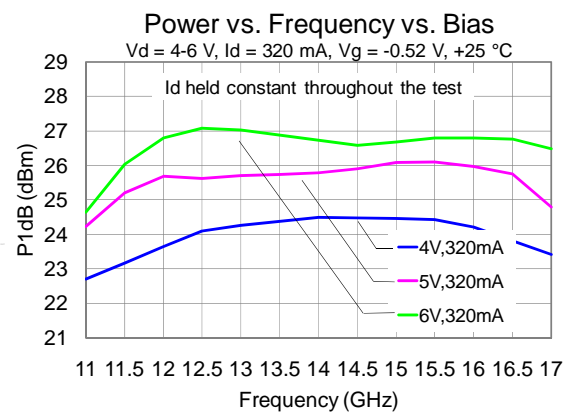
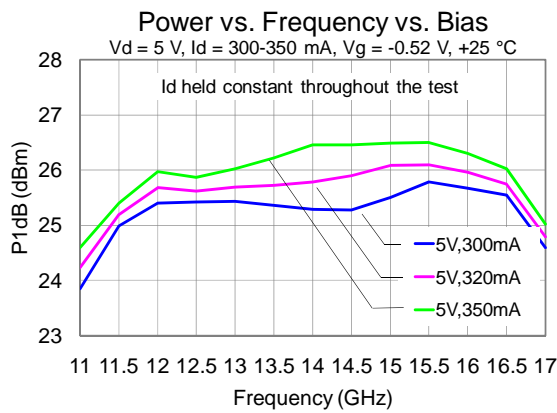
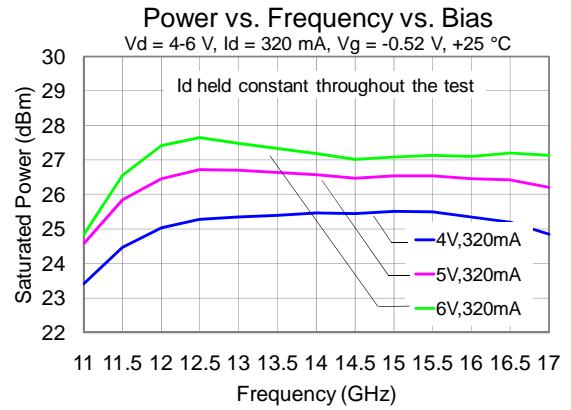
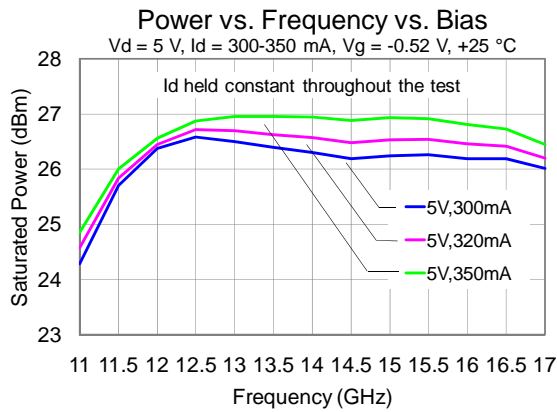

Typical Performance (cont.)

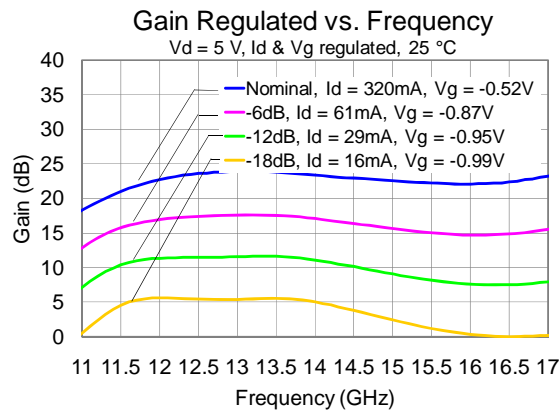
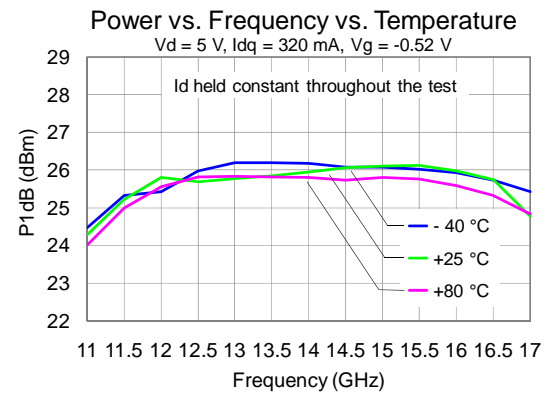
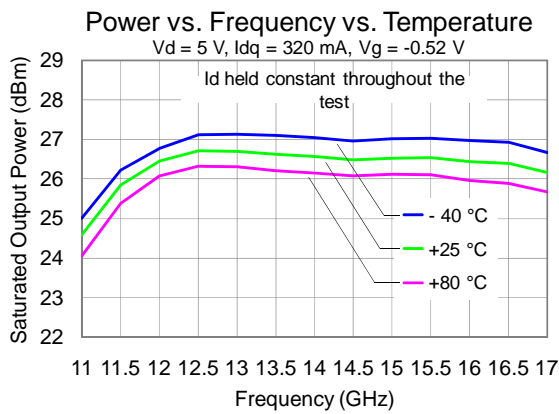
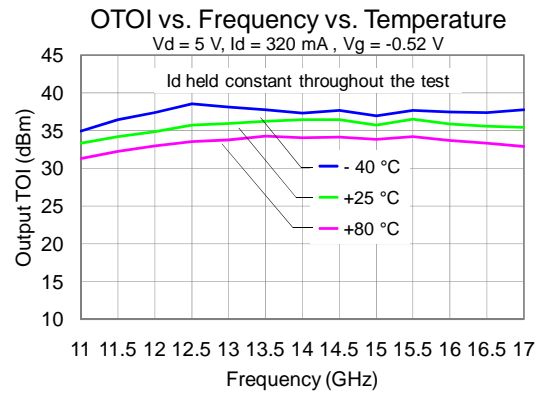
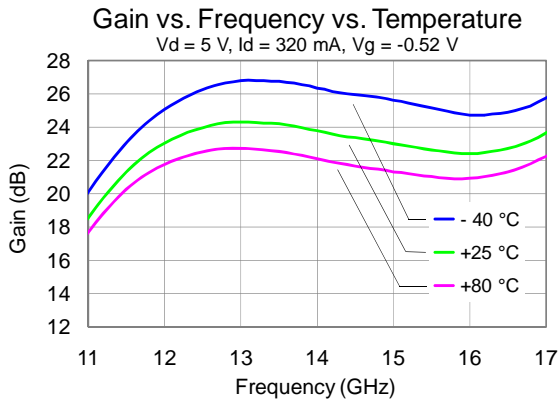

Application Circuit

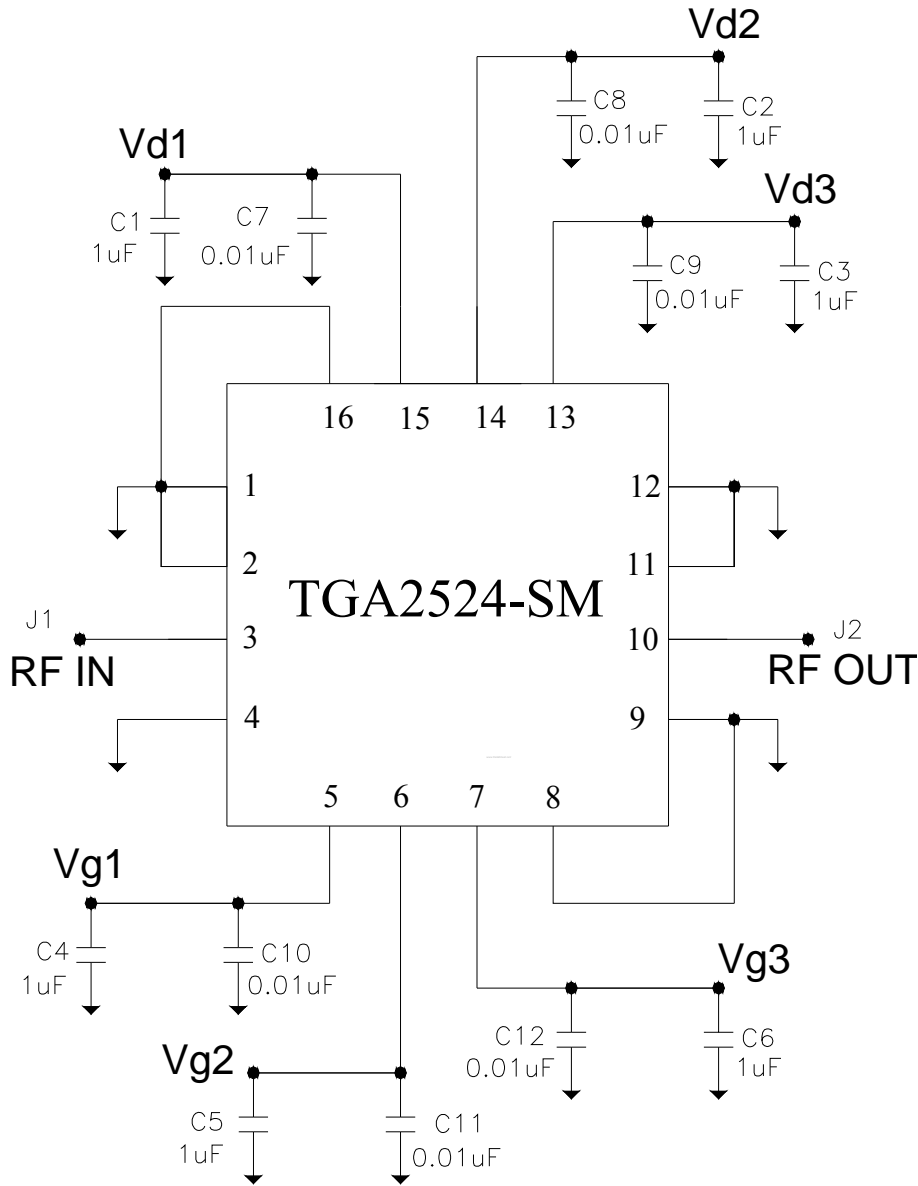

Bias-up Procedure

V_g (externally connect V_{g1}, V_{g2}, and V_{g3} together) set to -1.5 V
 V_d (externally connect V_{d1}, V_{d2}, and V_{d3} together) set to +5 V
 Adjust V_g more positive until quiescent I_d is 320 mA.
 This will be ~ V_g = -0.52 V typical
 Apply RF signal to RF Input

Bias-down Procedure

Turn off RF signal
 Reduce V_g to -1.5V. Ensure I_d ~ 0 mA
 Turn V_d to 0 V
 Turn V_g to 0 V

Pin Description

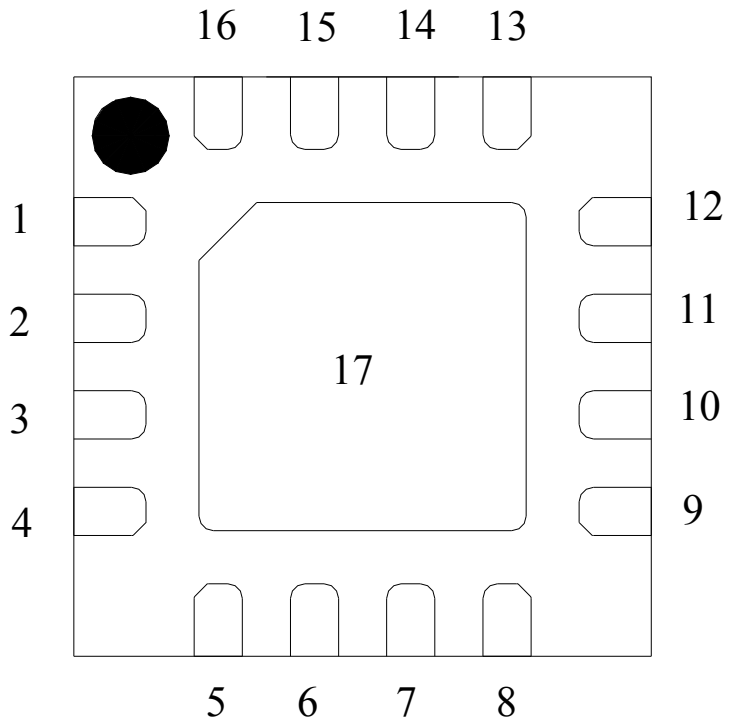

TOP VIEW

Pin	Symbol	Description
1, 2, 4, 8, 9, 11, 12, 16	N/C	No internal connection; must be grounded on PCB
3	RF IN	Input, matched to 50 ohms
5, 6, 7	Vg1, Vg2, Vg3	Gate voltage. Bias network is required; see Application Circuit on page 8 as an example. All three pins must be biased.
10	RF OUT	Output, matched to 50 ohms
13, 14, 15	Vd3, Vd2, Vd1	Drain voltage. Bias network is required; see Application Circuit on page 8 as an example. All three pins must be biased.
17	GND	Backside Paddle. Multiple vias should be employed to minimize inductance and thermal resistance; see Mounting Configuration on page 12 for suggested footprint.

Applications Information

PC Board Layout

Top RF layer is 0.008” thick Rogers RO4003, $\epsilon_r = 3.38$. Metal layers are 0.5-oz copper.

The pad pattern shown has been developed and tested for optimized assembly at TriQuint Semiconductor. The PCB land pattern has been developed to accommodate lead and package tolerances. Since surface mount processes vary from company to company, careful process development is recommended.

For further technical information, refer to the [TGA2524-SM](#) Product Information page.

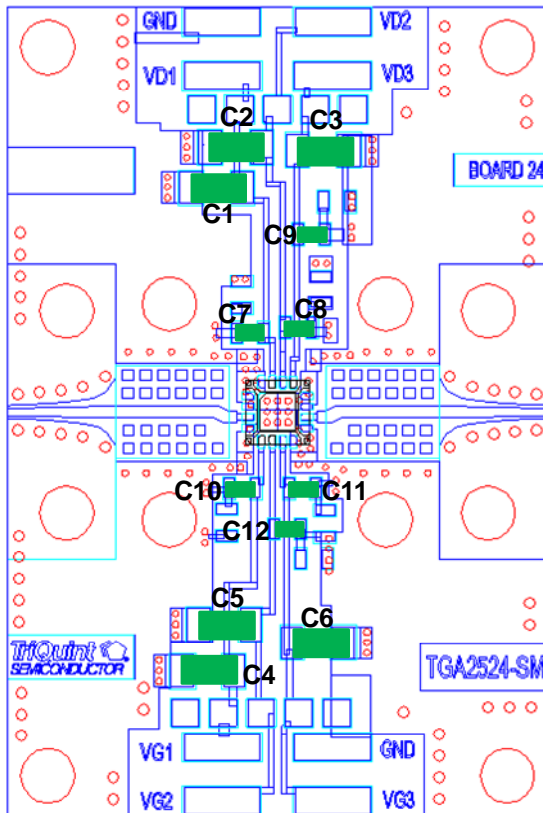
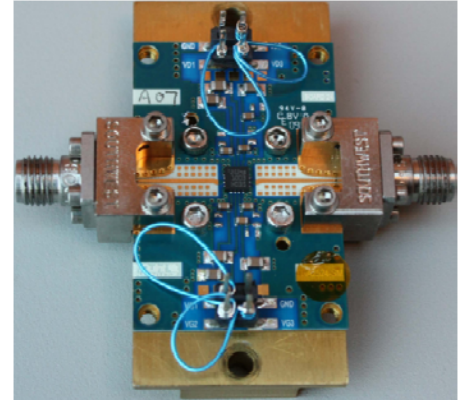

Bill of Material

Ref Des	Value	Description	Manufacturer	Part Number
C1- C6	1 uF	Cap, 1206, 50V, 5%, COG	AVX	12063C105KAT2A
C7-C12	0.01 uF	Cap, 0603, 50V, 5%, COG	AVX	06033C103KAT2A

Mechanical Information

Package Information and Dimensions

All dimensions are in millimeters.

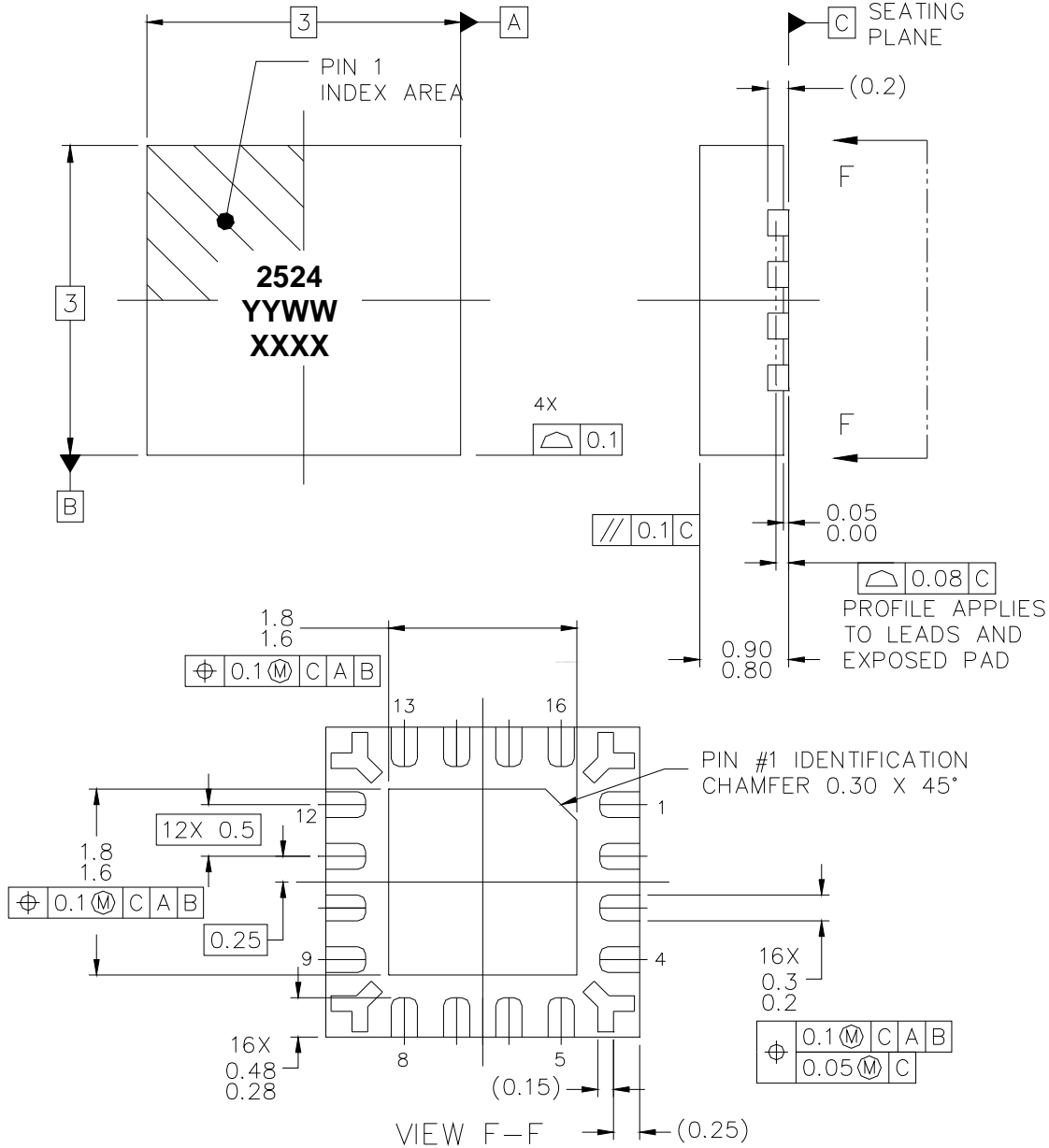

This package is lead-free/RoHS-compliant. The package base is copper alloy and the plating material on the leads is NiPdAu. It is compatible with both lead-free (maximum 260 °C reflow temperature) and tin-lead (maximum 245 °C reflow temperature) soldering processes.

The TGA2524-SM will be marked with the “2524” designator and a lot code marked below the part designator. The “YY” represents the last two digits of the year the part was manufactured, the “WW” is the work week, and the “XXXX” is an auto-generated number.

Mechanical Information (cont.)

Mounting Configuration

All dimensions are in millimeters (inches).

Notes:

1. Ground / thermal vias are critical for the proper performance of this device.
Vias have a final plated thru diameter of 0.254 mm (0.010").

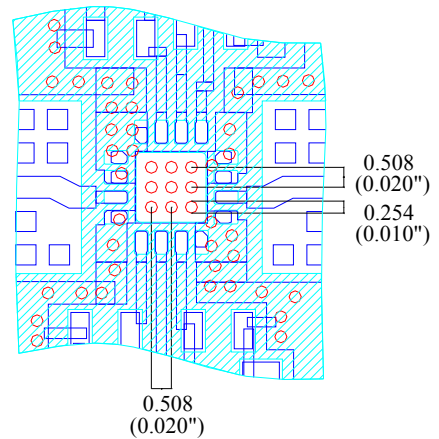

Tape and Reel Information

Tape and reel specifications for this part are also available on the TriQuint website in the “Application Notes” section.
Standard T/R size = 500 pieces on a 7 x 0.5” reel.

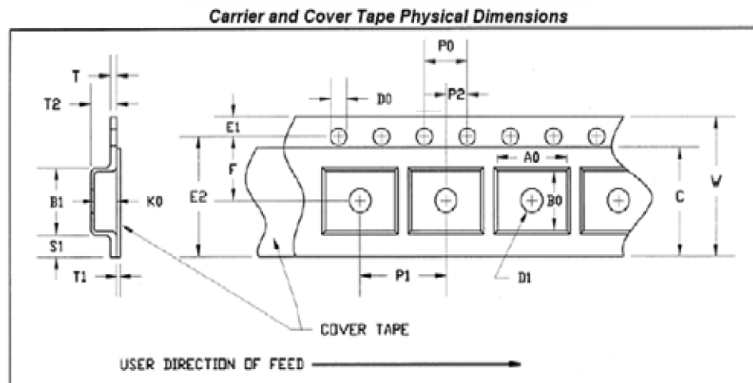

CARRIER AND COVER TAPE DIMENSIONS

Part	Feature	Symbol	Size (in)	Size (mm)
Cavity	Length	A0	0.134	3.40
	Width	B0	0.126	3.20
	Depth	K0	0.055	1.40
	Pitch	P1	0.157	4.00
Distance Between Centerline	Cavity to Perforation Length Direction	P2	0.079	2.00
	Cavity to Perforation Width Direction	F	0.138	3.50
Cover Tape	Width	C	0.213	5.40
Carrier Tape	Width	W	0.315	8.00

Product Compliance Information

ESD Information



Caution! ESD-Sensitive Device

ESD Rating: 1A
 Value: Passes ≥ 400 V min.
 Test: Human Body Model (HBM)
 Standard: JEDEC Standard JESD22-A114

MSL Rating

Level 1 at +260 °C convection reflow
 The part is rated Moisture Sensitivity Level TBD at 260°C per JEDEC standard IPC/JEDEC J-STD-020.

ECCN

US Department of Commerce EAR99

Solderability

Compatible with the latest version of J-STD-020, Lead free solder, 260°

This part is compliant with EU 2002/95/EC RoHS directive (Restrictions on the Use of Certain Hazardous Substances in Electrical and Electronic Equipment).

This product also has the following attributes:

- Lead Free
- Halogen Free (Chlorine, Bromine)
- Antimony Free
- TBBP-A (C₁₅H₁₂Br₄O₂) Free
- PFOS Free
- SVHC Free

Recommended Soldering Temperature Profile

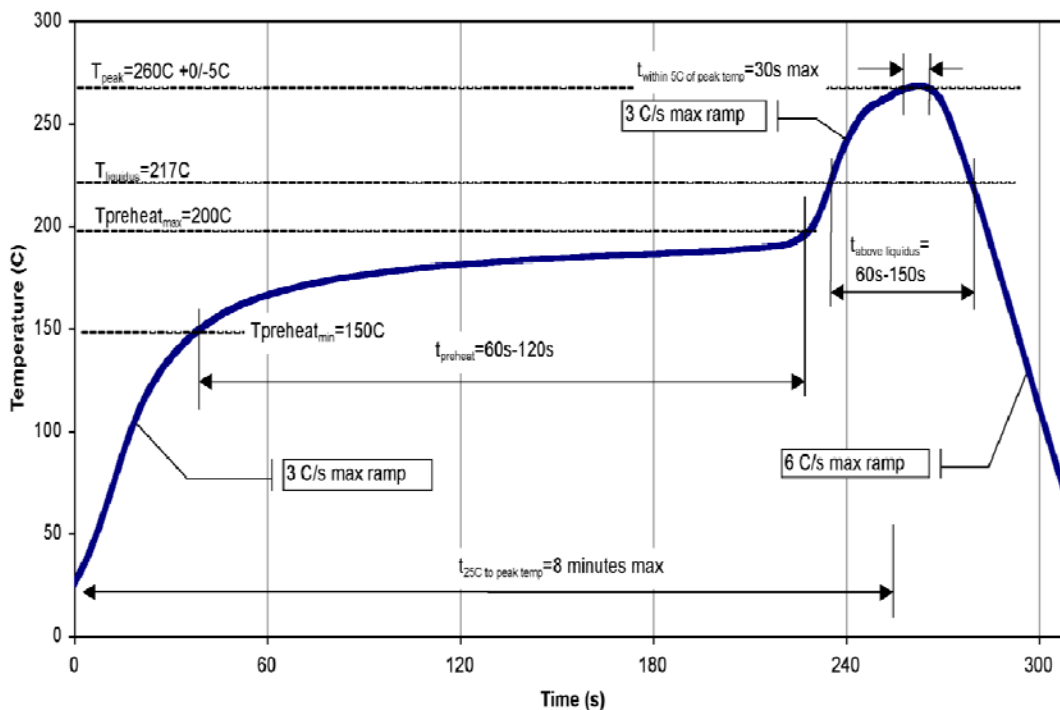

TGA2524-SM

Ku-Band Power Amplifier



Contact Information

For the latest specifications, additional product information, worldwide sales and distribution locations, and information about TriQuint:

Web: www.triquint.com
Email: info-sales@tqs.com

Tel: +1.972.994.8465
Fax: +1.972.994.8504

For technical questions and application information:

Email: info-networks@tqs.com

Important Notice

The information contained herein is believed to be reliable. TriQuint makes no warranties regarding the information contained herein. TriQuint assumes no responsibility or liability whatsoever for any of the information contained herein. TriQuint assumes no responsibility or liability whatsoever for the use of the information contained herein. The information contained herein is provided "AS IS, WHERE IS" and with all faults, and the entire risk associated with such information is entirely with the user. All information contained herein is subject to change without notice. Customers should obtain and verify the latest relevant information before placing orders for TriQuint products. The information contained herein or any use of such information does not grant, explicitly or implicitly, to any party any patent rights, licenses, or any other intellectual property rights, whether with regard to such information itself or anything described by such information.

TriQuint products are not warranted or authorized for use as critical components in medical, life-saving, or life-sustaining applications, or other applications where a failure would reasonably be expected to cause severe personal injury or death.