

2.5GHz WiMAX Driver / Power Amplifier
TGA2702-SM

Key Features

- 2.3-2.8 GHz Bandwidth
- 2.5% EVM @ 23 dBm Pout (2.6GHz 802.11g OFDM waveform)
- 39 dBc IMD3 @ 21 dBm Pout/tone
- 28 dB Nominal Gain
- 29.8 dBm Nominal P1dB
- 16 dB step attenuator function
- Power sample port
- Bias: +6 V (Single Bias)
- Package Dimensions:
5.0 x 5.0 x 0.9 mm QFN

Primary Applications

- Fixed Broadband Wireless
- 2.5GHz WiMAX
- WiBro

General Description

TGA2702-SM is a linear amplifier operating for 802.16 fixed broadband wireless applications across the 2.3 to 2.8 GHz frequency band. Application include WiMAX, 802.11g and WiBro. The PA delivers 28 dB of small-signal gain and Pout of 23dBm @ 2.5% EVM (2.6GHz 802.11g OFDM waveform) from a single +6V power supply. The TGA2702 incorporates an 16 dB step attenuator function and a power sample port. The 50 ohm device requires minimum external components for operation, and is packaged in a low-cost, surface mount 5x5 QFN style package.

Lead-Free & RoHS compliant

Demo boards are available.

Preliminary Measured Data

Bias Conditions: $V_d = +6$ V Self Bias

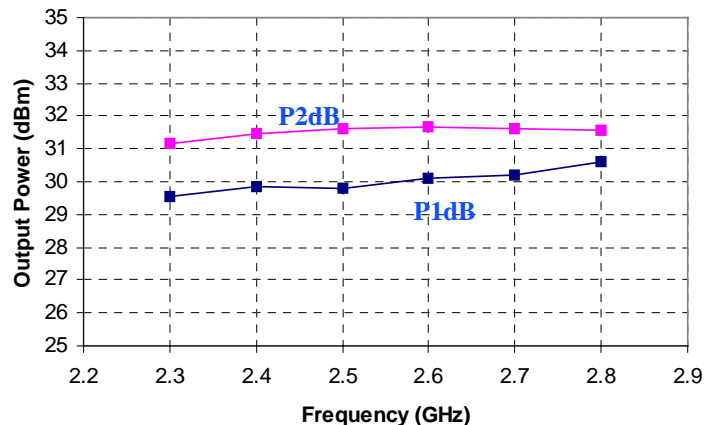
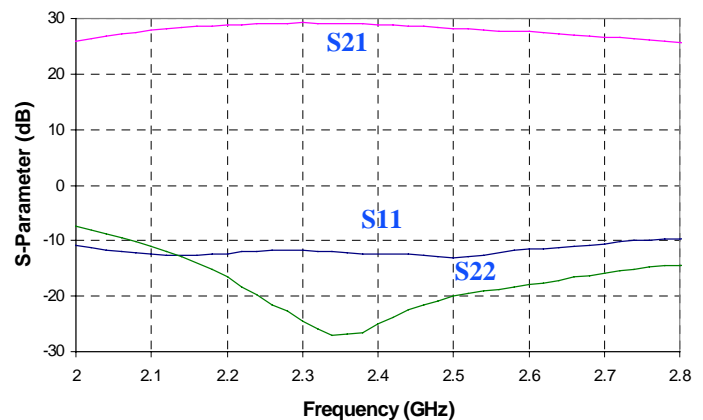

Note: This device is early in the characterization process prior to finalizing all electrical specifications. Specifications are subject to change without notice.

TABLE I
MAXIMUM RATINGS ^{1/}

SYMBOL	PARAMETER	VALUE	NOTES
V _d	Drain Voltage	7 V	<u>2/</u>
V _{ctrl}	Gain Control Voltage	7 V	
I _d	Drain Current	1.1 A	<u>2/ 3/</u>
I _g	Gate Current	6 mA	<u>3/</u>
P _{IN}	Input Continuous Wave Power	25 dBm	
P _D	Power Dissipation	4.68W	<u>2/ 4/</u>
T _{CH}	Operating Channel Temperature	150 °C	<u>5/</u>
T _M	Mounting Temperature (30 Seconds)	260 °C	
T _{STG}	Storage Temperature	-65 to 150 °C	

- 1/ These ratings represent the maximum operable values for this device.
- 2/ Combinations of supply voltage, supply current, input power, and output power shall not exceed P_D.
- 3/ Total current for the device.
- 4/ When operated at this bias condition with a base plate temperature of 85 °C, the median life is reduced.
- 5/ Junction operating temperature will directly affect the device median time to failure (MTTF). For maximum life, it is recommended that junction temperatures be maintained at the lowest possible levels.

TABLE II
ELECTRICAL CHARACTERISTICS
(Ta = 25 °C Nominal)

Response	Units	Typical	Notes
Frequency Band	GHz		2.3 - 2.8
Drain Operating Voltage	V	6	
Small Signal Gain	dB	28	
Input Return Loss	dB	12	
Output Return Loss	dB	14	
Control Gain Step	dB	16	
Psat	dBm	31.5	Pin at 11 dBm
P1dB	dBm	30	
EVM	%	2.5	at 2.6GHz, 23 dBm Pout
Gain variation over temperature	dB/°C	0.03	
IMD3	dBc	38	at 21 dBm Pout/tone
TOI	dBm	40	at 21 dBm Pout/tone

TABLE III
THERMAL INFORMATION

Parameter	Test Conditions	T _{CH} (°C)	R _{θJC} (°C/W)	T _M (HRS)
R _{θJC} Thermal Resistance (channel to backside of package)	Vd = 6V I _D = 0.77 A Pdiss = 4.62 W	145.5	13.1	3.8E+6

Note: Package backside soldered to carrier at 85°C baseplate temperature.

Preliminary Measured Data

Bias Conditions: $V_d = 6\text{ V}$, $I_d = 750\text{ mA}$ Self Bias

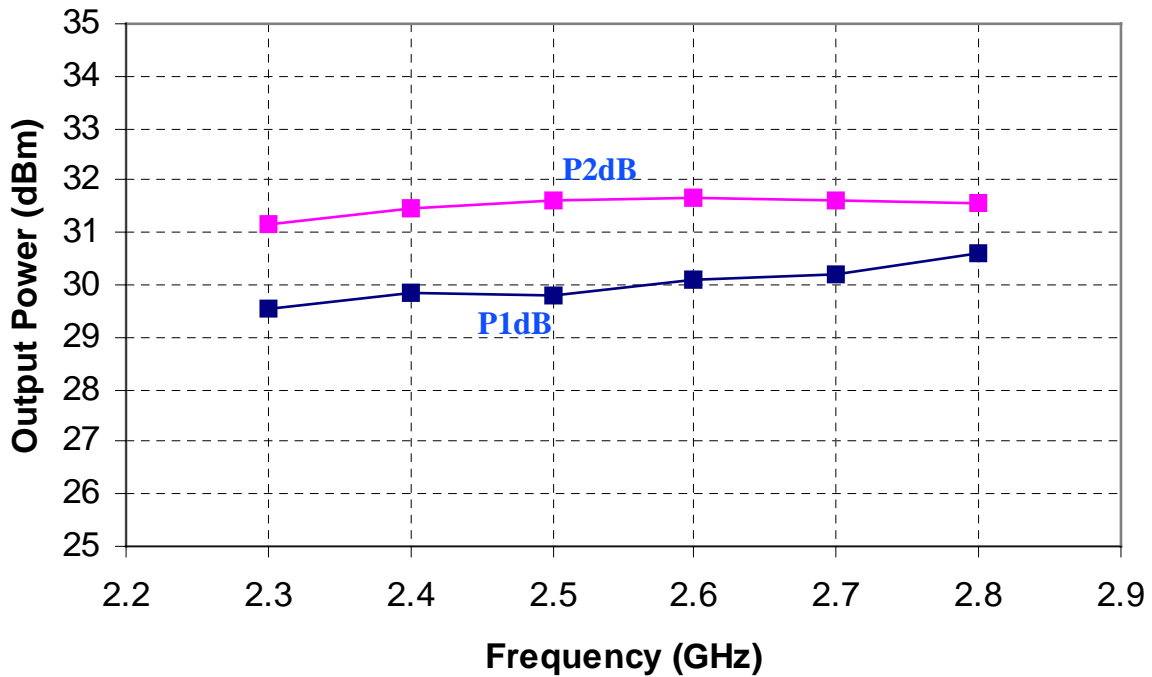
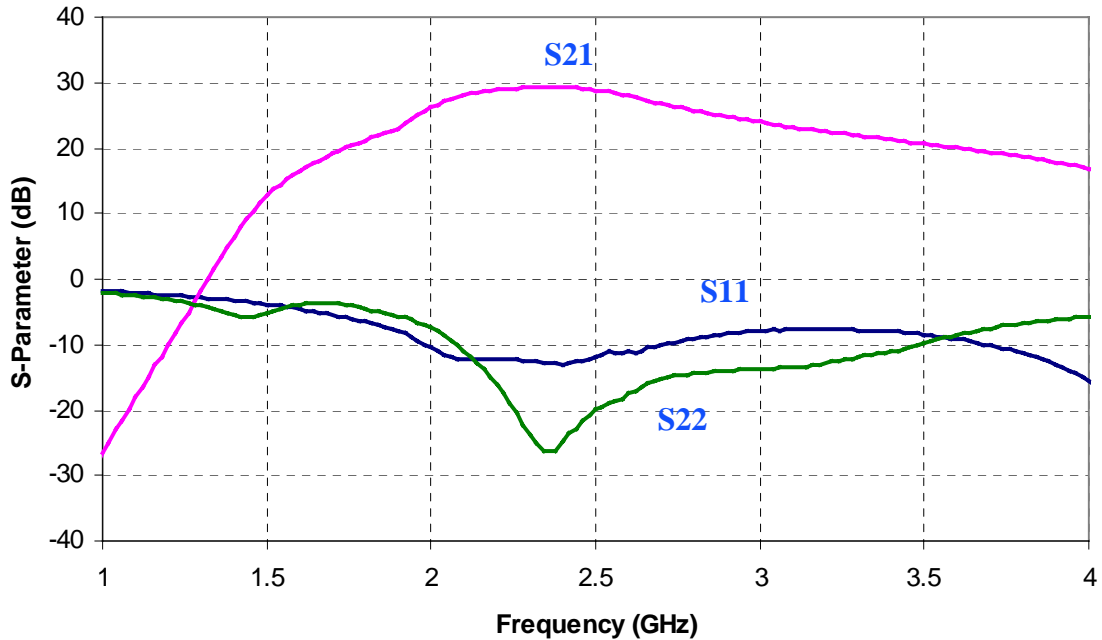

Preliminary Measured Data

Bias Conditions: Vd = 6 V, Id =750 mA Self Bias

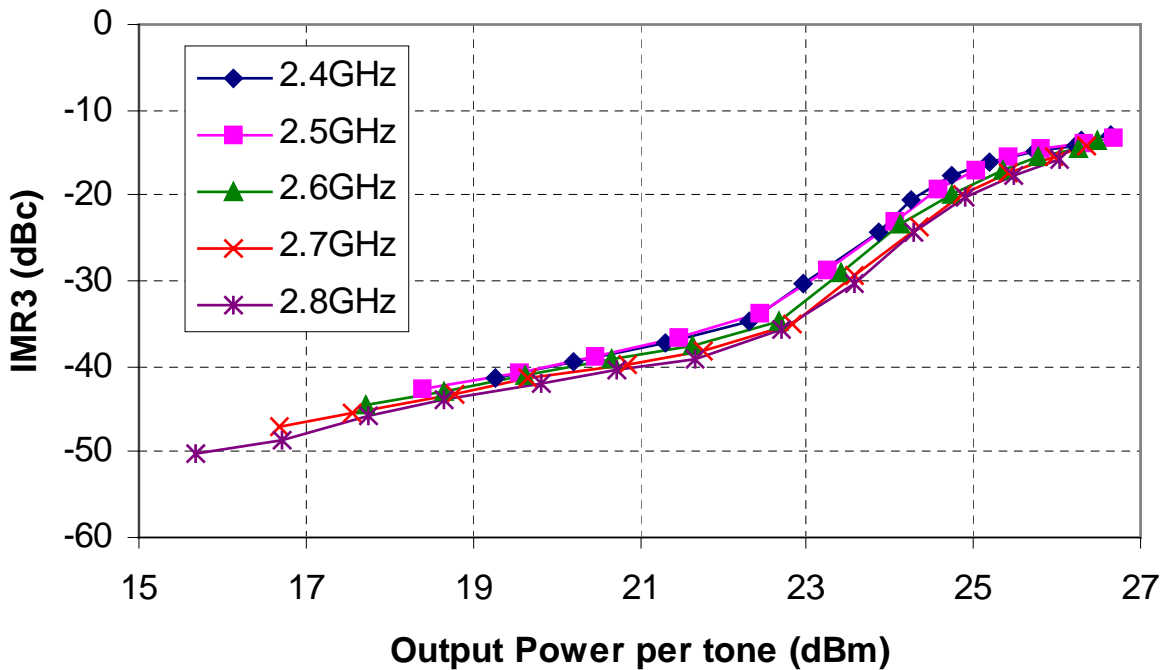
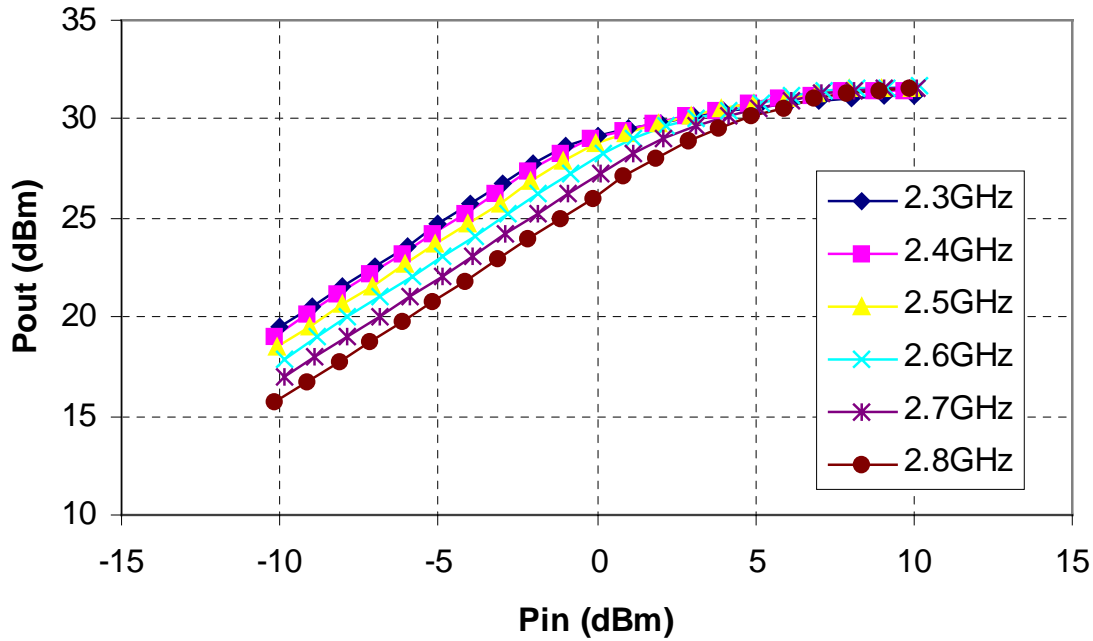

Preliminary Measured Data

Bias Conditions: $V_d = 6\text{ V}$, $I_d = 750\text{ mA}$ Self Bias

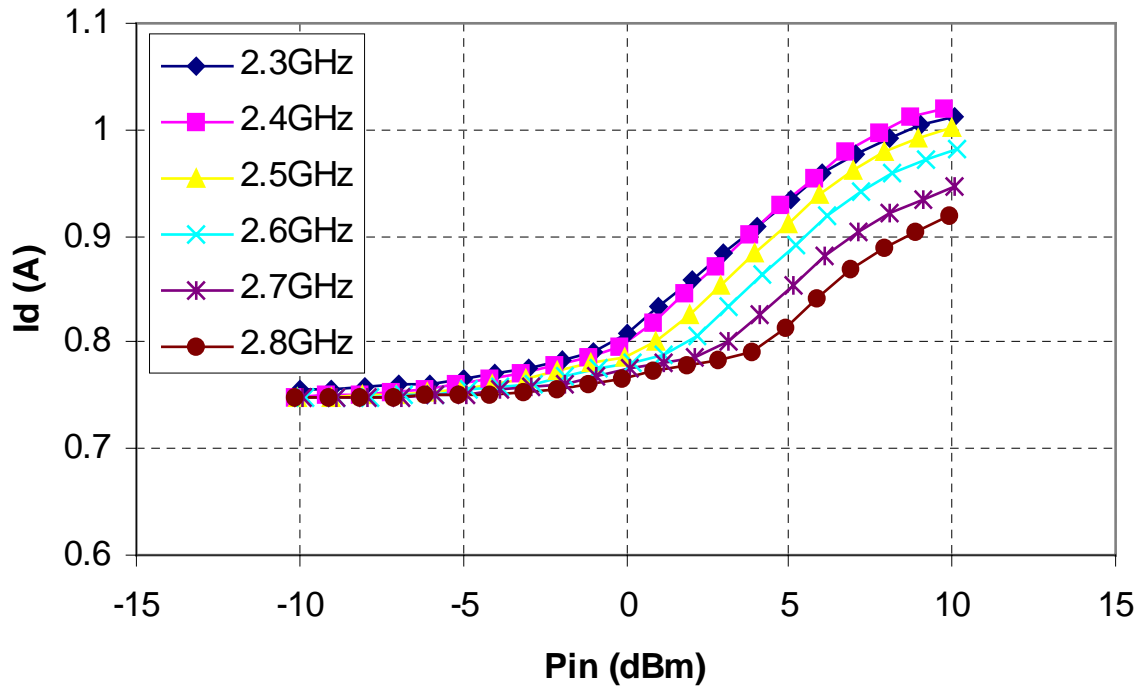

802.11g, OFDM, 64QAM

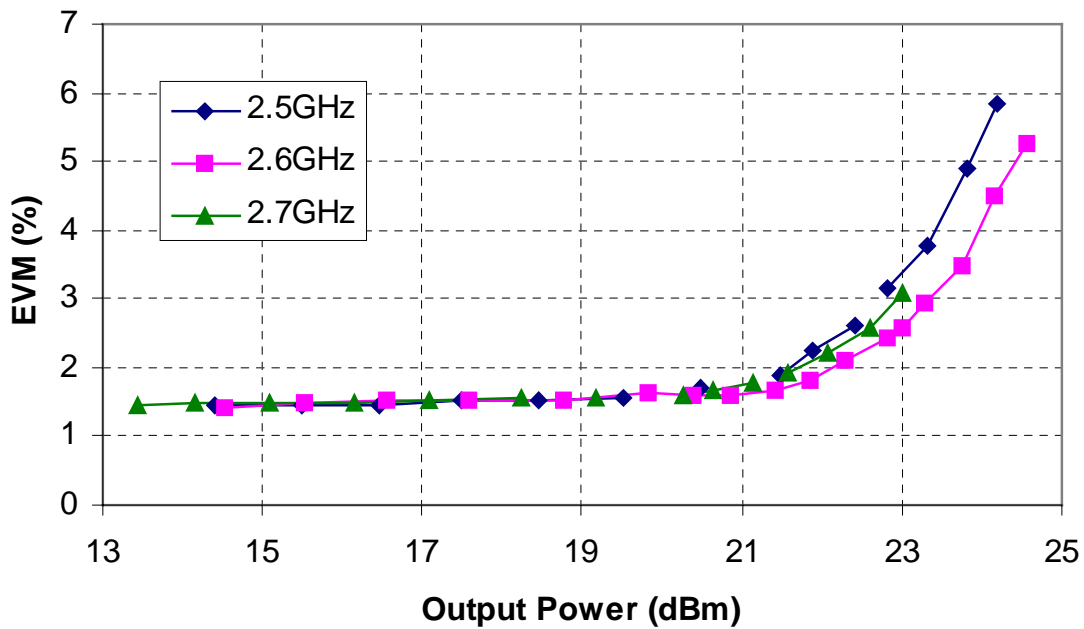

Preliminary Measured Data

Bias Conditions: $V_d = 6\text{ V}$, $I_d = 750\text{ mA}$ Self Bias

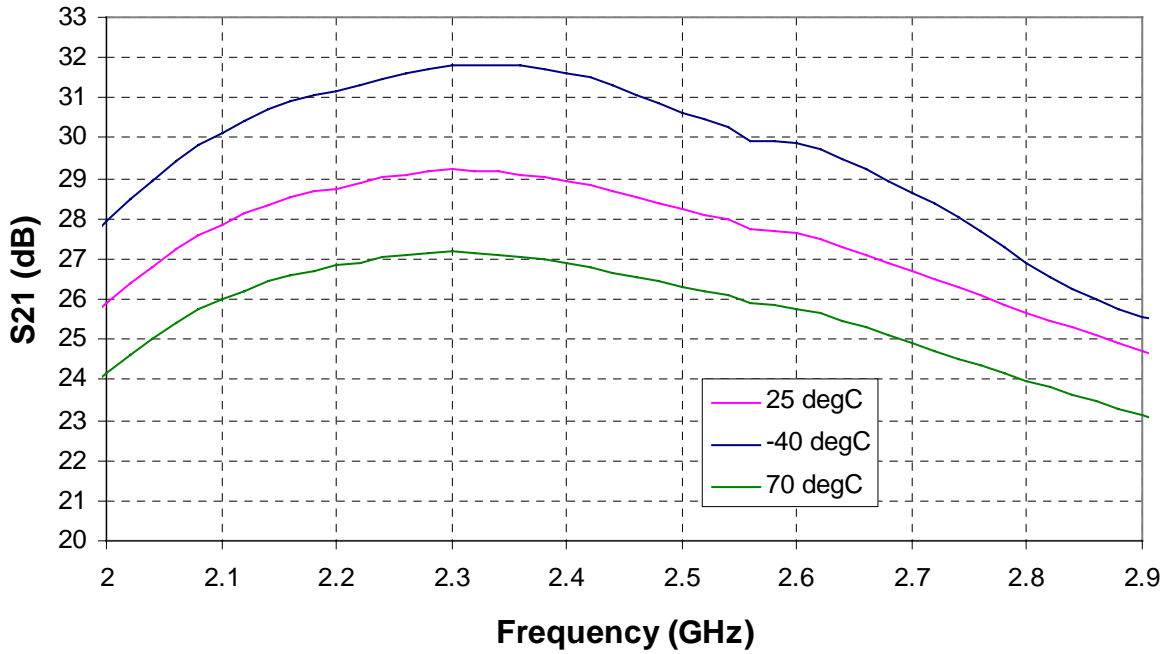

Package Layout



Top View

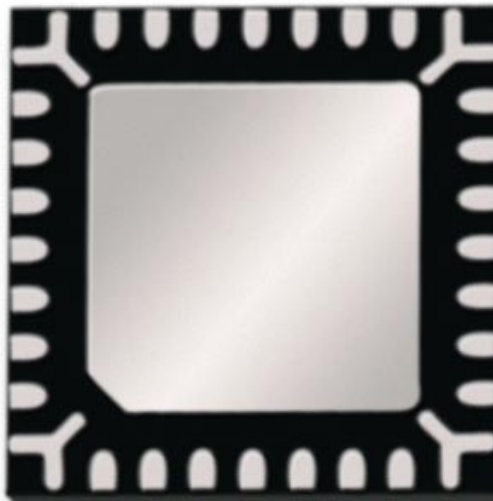

Bottom View

Package Pinout Diagram



Top Side

Dot indicates Pin 1

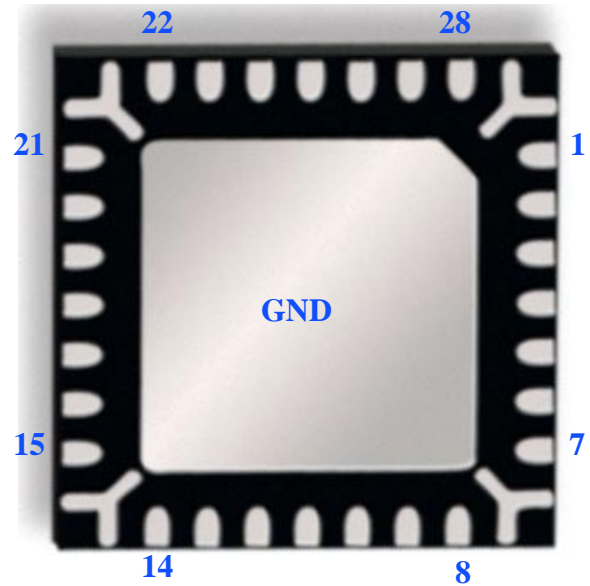

Bottom Side

Pin	Description	Pin	Description
1,2,3	NC	14	Power Sample
4	RF Input	18	RF Output
5,6,7,8,9	NC	19,20,21	NC
10	Gain Control	22	Vd2
11,13	NC	23,24,25	NC
12	Gate Access	26	Vd1
15,16,17	NC	27,28	NC

Mechanical Drawing
(Bottom Side)

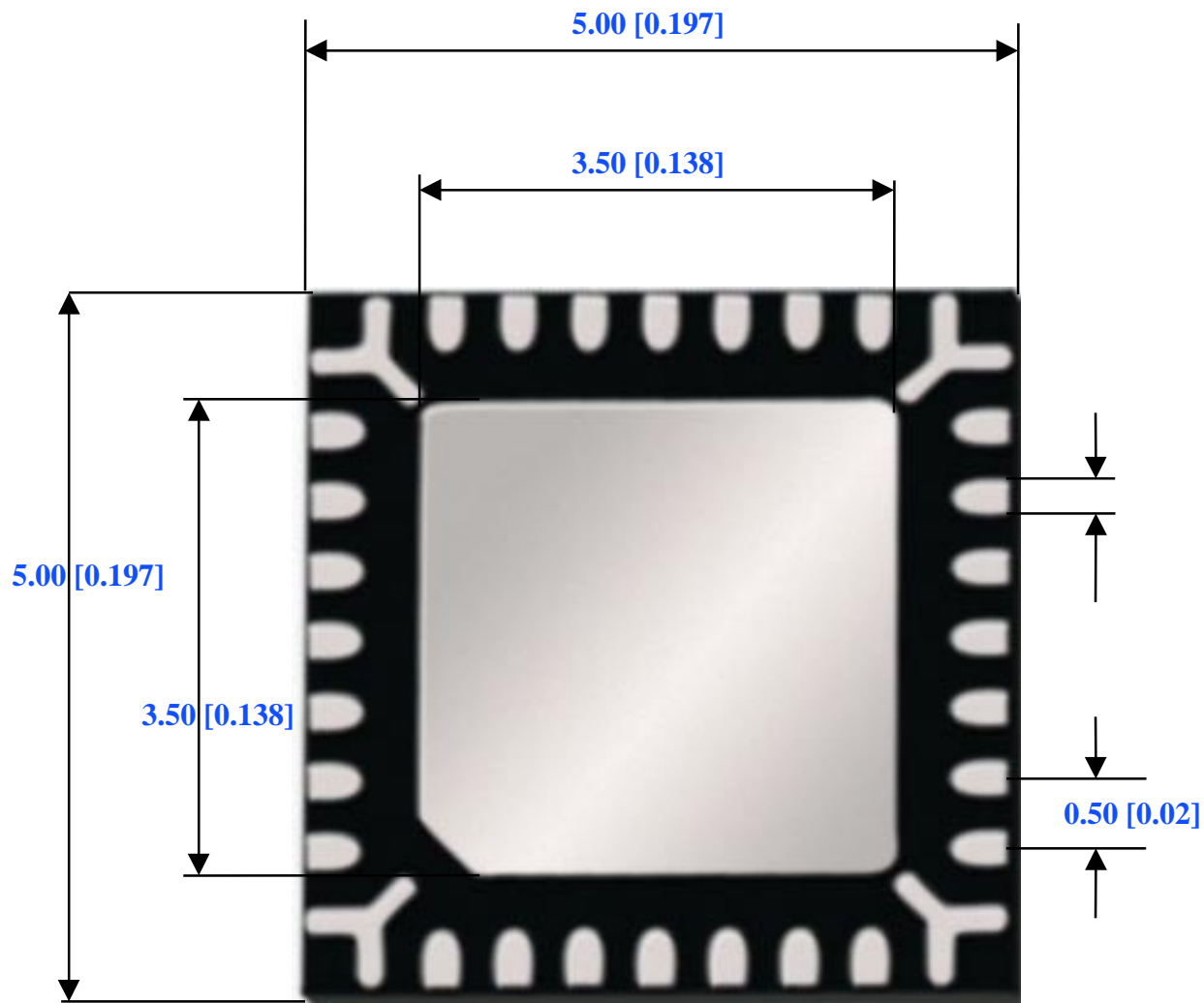

Units: mm [Inch]

Package tolerance: +/- 0.05

Recommended Board Layout Assembly

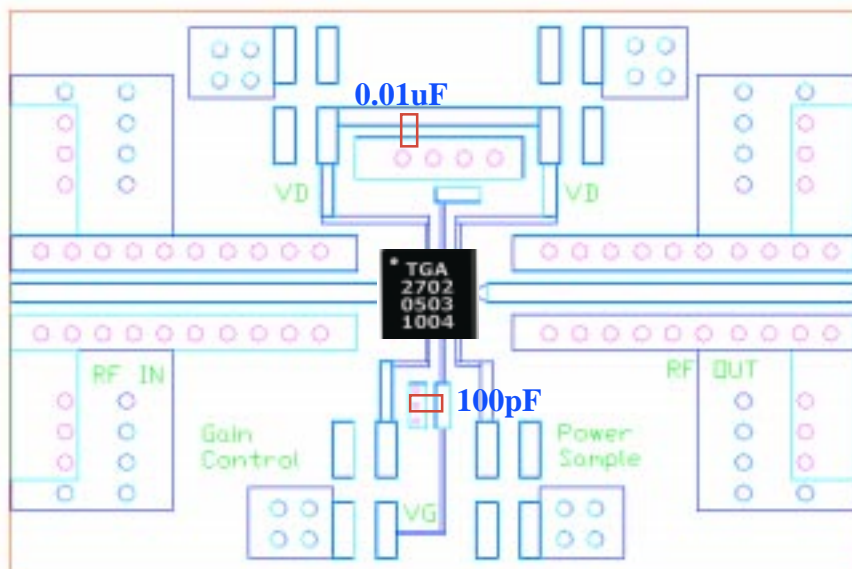

- The evaluation board material is 20 mil thick RO4003
- 100 pF and 0.01 uF are required de-coupling capacitor

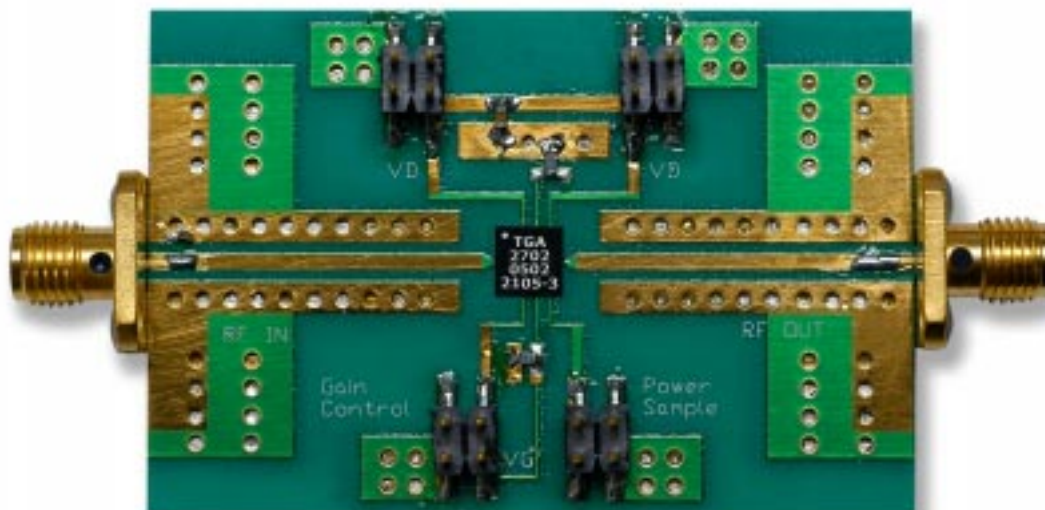

TGA2702 Bias Connection Self-biased mode

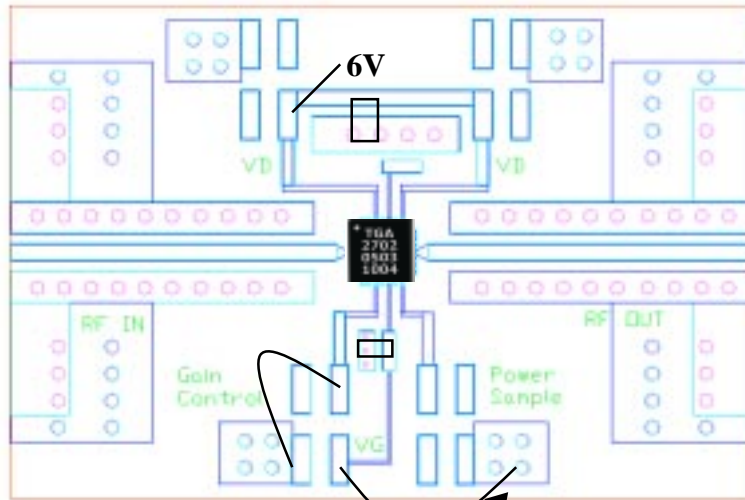

4 inch or longer jumper
or 10nH inductor

Connect gain control and Vg to ground.
Apply +6V to Vd. Current will be ~750mA

Gate control mode

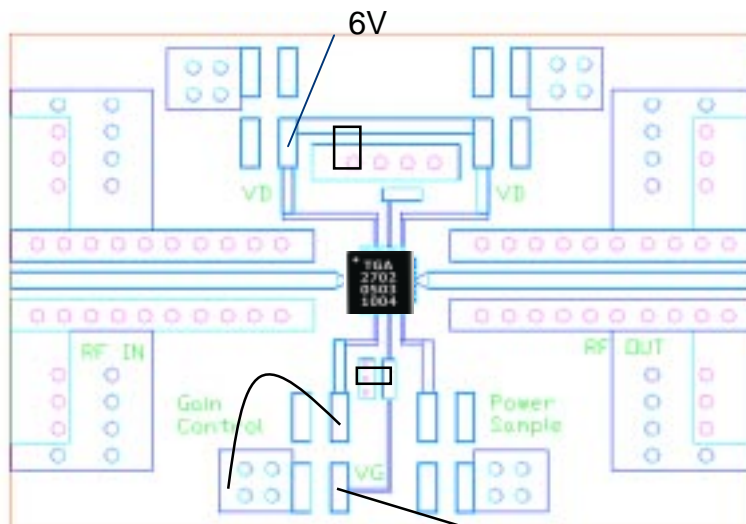

Vg

Connect gain control to ground. Apply negative voltage Vg.
Apply +6V to Vd. Current will be ~750mA

TGA2702 Bias Connection Gain control mode

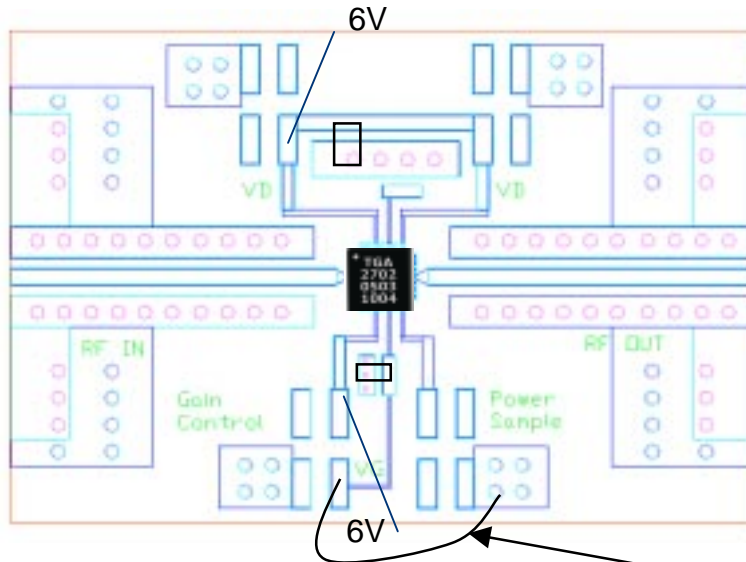

For 16 dB attenuation testing:

**4 inch or longer jumper
or 10nH inductor**

Connect gain control to +6V and Vg to ground.
Apply +6V to Vd. Current will be ~750mA

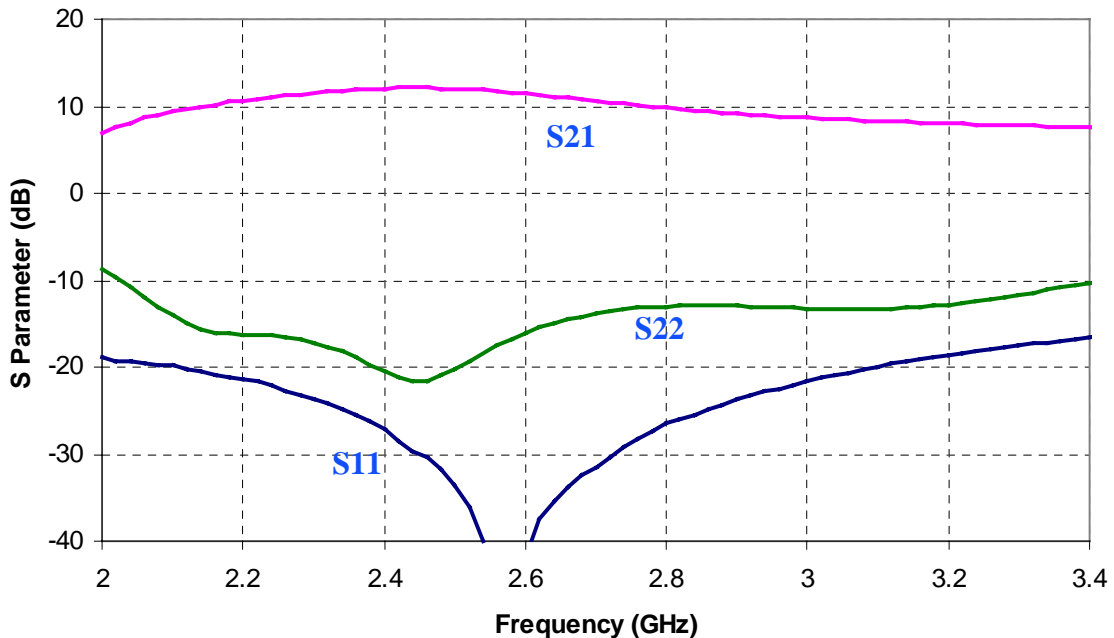

Recommended Surface Mount Package Assembly

Proper ESD precautions must be followed while handling packages.

Clean the board with acetone. Rinse with alcohol. Allow the circuit to fully dry.

TriQuint recommends using a conductive solder paste for attachment. Follow solder paste and reflow oven vendors' recommendations when developing a solder reflow profile. Typical solder reflow profiles are listed in the table below.

Hand soldering is not recommended. Solder paste can be applied using a stencil printer or dot placement. The volume of solder paste depends on PCB and component layout and should be well controlled to ensure consistent mechanical and electrical performance.

Clean the assembly with alcohol.

Typical Solder Reflow Profiles

Reflow Profile	SnPb	Pb Free
Ramp-up Rate	3 °C/sec	3 °C/sec
Activation Time and Temperature	60 – 120 sec @ 140 – 160 °C	60 – 180 sec @ 150 – 200 °C
Time above Melting Point	60 – 150 sec	60 – 150 sec
Max Peak Temperature	240 °C	260 °C
Time within 5 °C of Peak Temperature	10 – 20 sec	10 – 20 sec
Ramp-down Rate	4 – 6 °C/sec	4 – 6 °C/sec