

## 4 Watt 802.11a Packaged Amplifier

## TGA2921-SG



### Key Features

- 4.9 - 6 GHz Application Frequency Range
- 11 dB Nominal Gain @ 8V 800mA
- 36 dBm Nominal P1dB @ 8V 800mA
- 2.5% EVM at 26 dBm output power
- IMD3 -50dBc @ 24dBm SCL, Typical
- Bias Conditions: 7-9 V @ 700-800 mA (Quiescent)
- 0.5  $\mu$ m HFET Technology
- 2 lead Cu base SMT package

### Primary Applications

- 802.11a WLAN Bridge Amplifiers
- U-NII Band HPA
- C-Band Pt-Pt and Pt-Multi Pt Radio

### Product Description

The TGA2921-SG HPA provides 11 dB of gain, 4 W of output power across 4.9 - 6 GHz and 2.5% EVM at 26 dBm output power. The device is ideally suited for high linearity, high power wireless data applications such as 802.11a WLAN Bridge Amplifiers, U-NII and Point-to-Point or Point-to-Multi-Point Non-Line of Sight radios. The package has a high thermal conductivity copper base. Internal partial matching simplifies system board layout by requiring a minimum of external components.

Lead-Free & RoHS compliant.

Evaluation Boards are available.

### Fixtured Measured Performance

Bias Conditions:  $V_d = 8$  V,  $I_{dq} = 800$  mA

Performance data taken @ in a 5.75GHz application circuit

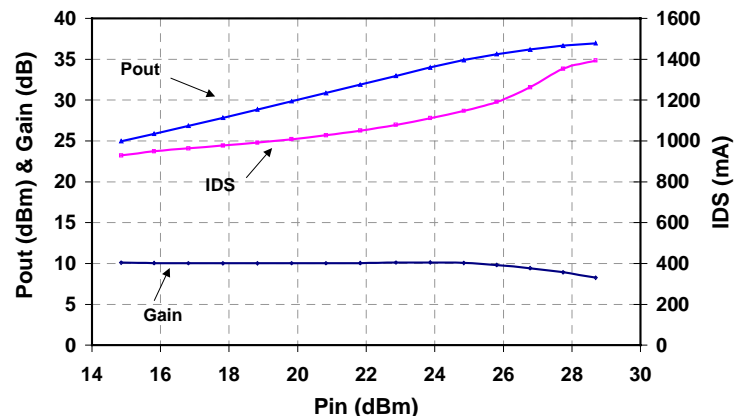
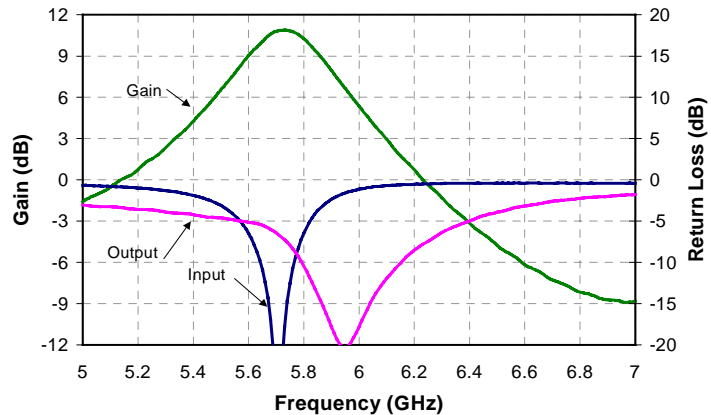

Note: This device is early in the characterization process prior to finalizing all electrical specifications. Specifications are subject to change without notice.

TABLE I  
MAXIMUM RATINGS 1/

Symbol	Parameter	Value	Notes
V <sub>d</sub>	Drain Supply Voltage	10 V	<u>2/</u>
V <sub>g</sub>	Gate Supply Voltage Range	0 V to -5 V	
I <sub>dq</sub>	Drain Supply Current (Quiescent)	2 A	<u>2/</u>
I <sub>g</sub>	Gate Current	38 mA	
P <sub>IN</sub>	Input Continuous Wave Power	30 dBm	<u>2/</u>
P <sub>D</sub>	Power Dissipation	7.9 W	<u>2/</u> , <u>3/</u>
T <sub>CH</sub>	Operating Channel Temperature	175 °C	4/
T <sub>M</sub>	Mounting Temperature (30 Seconds)	260 °C	
T <sub>STG</sub>	Storage Temperature	-65 to 150 °C	

- 1/ These ratings represent the maximum operable values for this device.
- 2/ Combinations of supply voltage, supply current, input power, and output power shall not exceed P<sub>D</sub>.
- 3/ When operated at this bias condition with a base plate temperature of 85 °C, the MTTF life is 2 E+8 hours.
- 4/ Junction operating temperature will directly affect the device median time to failure (T<sub>M</sub>). For maximum life, it is recommended that junction temperatures be maintained at the lowest possible levels.

**TABLE II**  
**RF CHARACTERIZATION TABLE**  
 (T<sub>A</sub> = 25°C, Nominal)  
 (V<sub>d</sub> = 8 V, I<sub>dq</sub> = 800 mA)

SYMBOL	PARAMETER	TEST CONDITION	TYPICAL	UNITS
Gain	Small Signal Gain	F = 5.75 GHz	11	dB
IRL	Input Return Loss	F = 5.75 GHz	12	dB
ORL	Output Return Loss	F = 5.75 GHz	7	dB
P1dB	Output Power @ P1dB	F = 5.75 GHz	36	dBm

**TABLE III**  
**THERMAL INFORMATION**

Parameter	Test Conditions	T <sub>CH</sub> (°C)	R <sub>θJC</sub> (°C/W)	T <sub>M</sub> (HRS)
R <sub>θJC</sub> Thermal Resistance (channel to backside of package)	V <sub>d</sub> = 8 V I <sub>D</sub> = 800 mA (Quiescent) P <sub>diss</sub> = 6.4 W	155	11	1.6 E+9

Note: Package backside SnPb soldered to carrier at 85°C baseplate temperature. At saturated output power, the DC power consumption is 11.2 W with 4 W RF power delivered to the load. Power dissipated is 7.2 W and the temperature rise in the channel is 79 °C.

**Measured Fixtured Data**  
**Application Circuit tuned to 5.75 GHz**

**Bias Conditions:  $V_d = 7\text{ V}$ ,  $I_{dq} = 700\text{ mA}$**

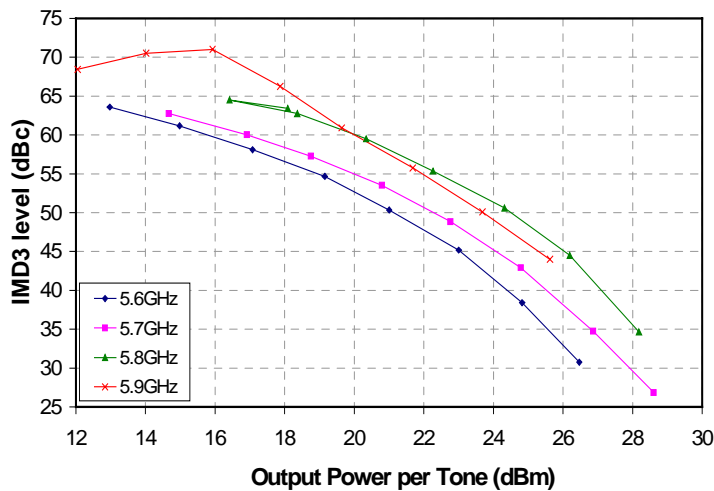
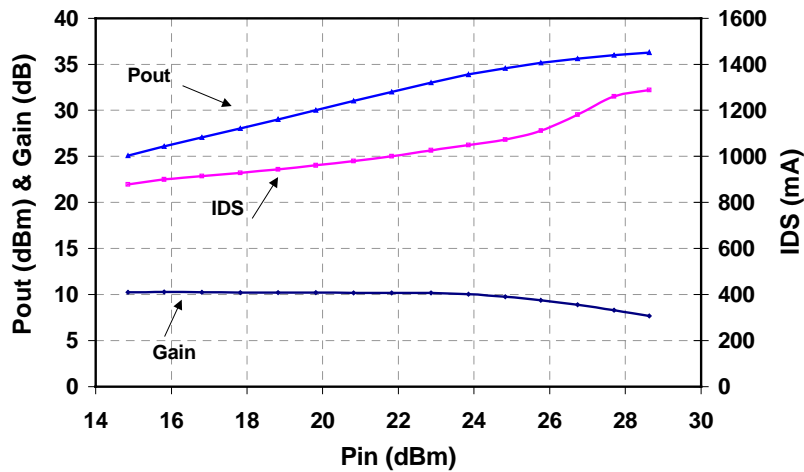
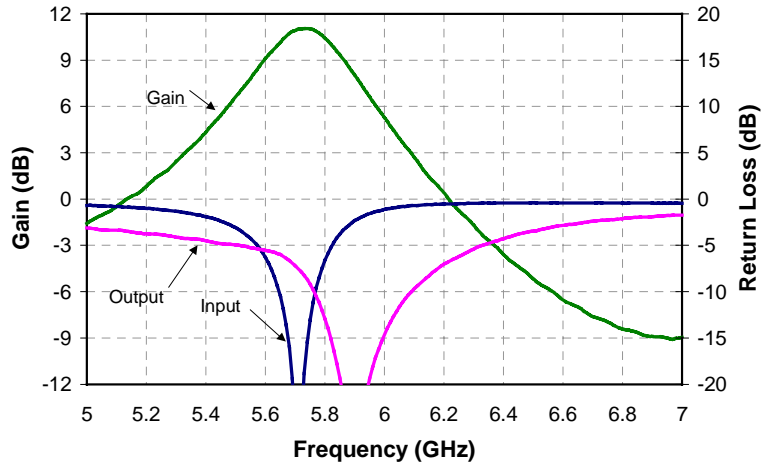

**Measured Fixtured Data**  
**Application Circuit tuned to 5.75 GHz**

**Bias Conditions:  $V_d = 8\text{ V}$ ,  $I_{dq} = 800\text{ mA}$**

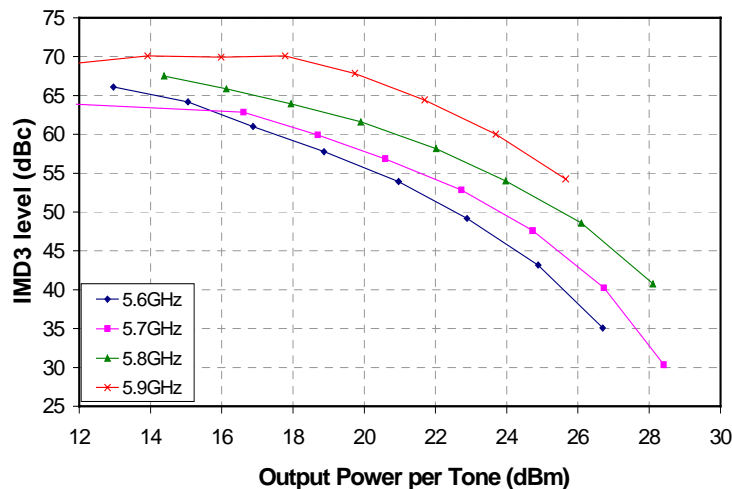
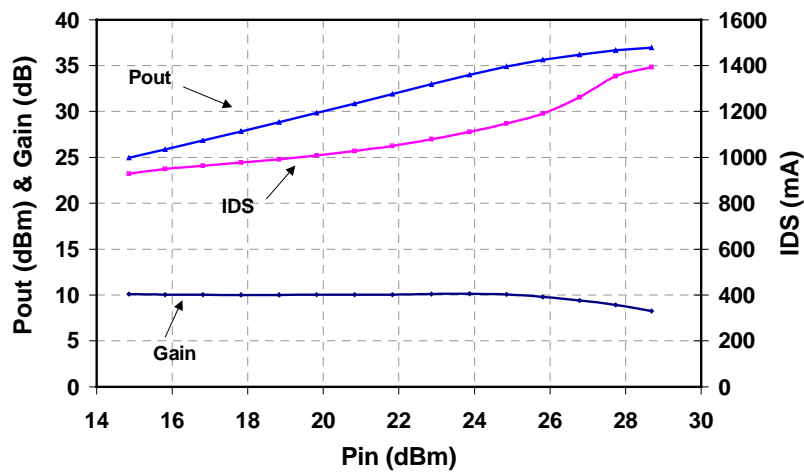
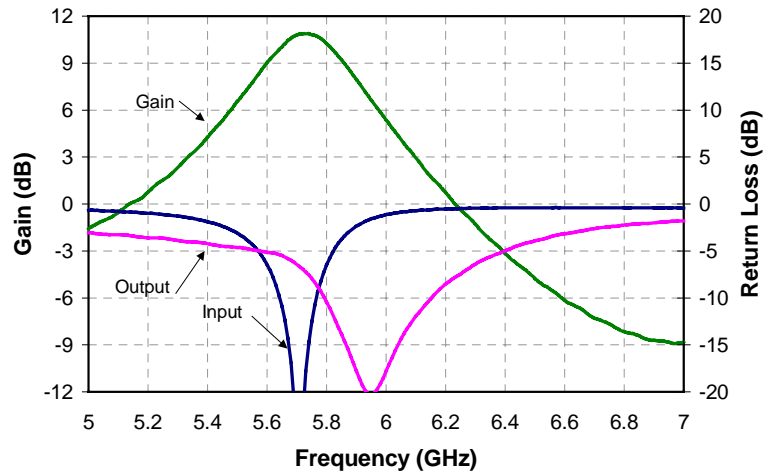

**Measured Fixtured Data**  
**Application Circuit tuned to 5.75 GHz**

**Bias Conditions:  $V_d = 8\text{ V}$ ,  $I_{dq} = 800\text{ mA}$**

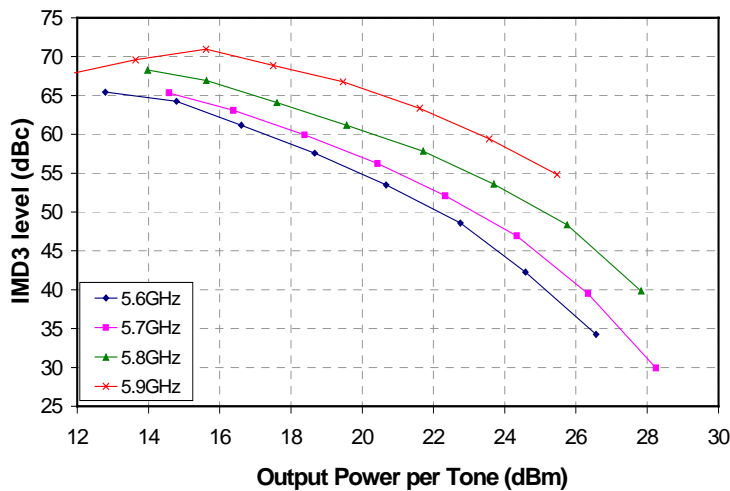
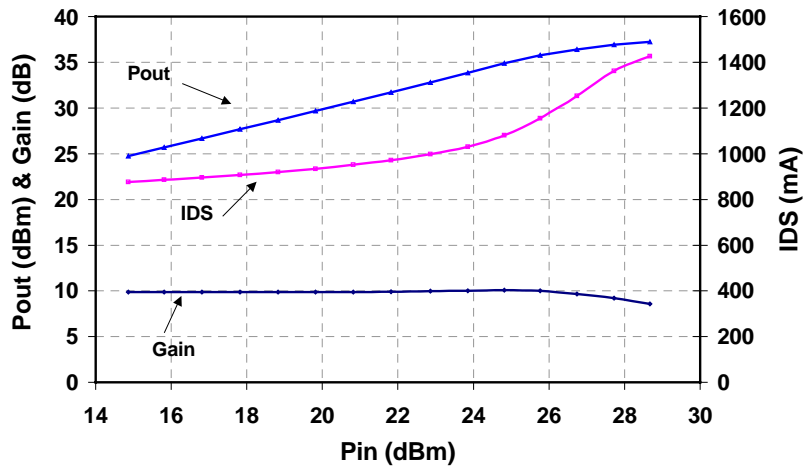
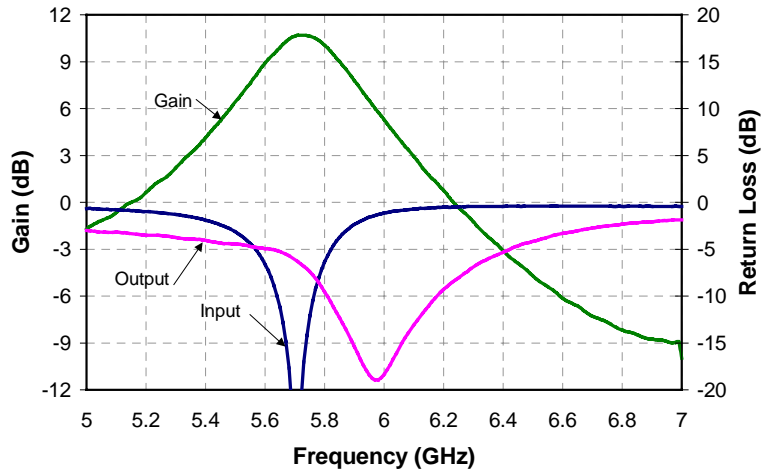

**Measured Fixtured Data**  
**Application Circuit tuned to 5.75 GHz**

**Bias Conditions:  $V_d = 8\text{ V}$ ,  $I_{dq} = 800\text{ mA}$**

**OFDM 64 QAM**

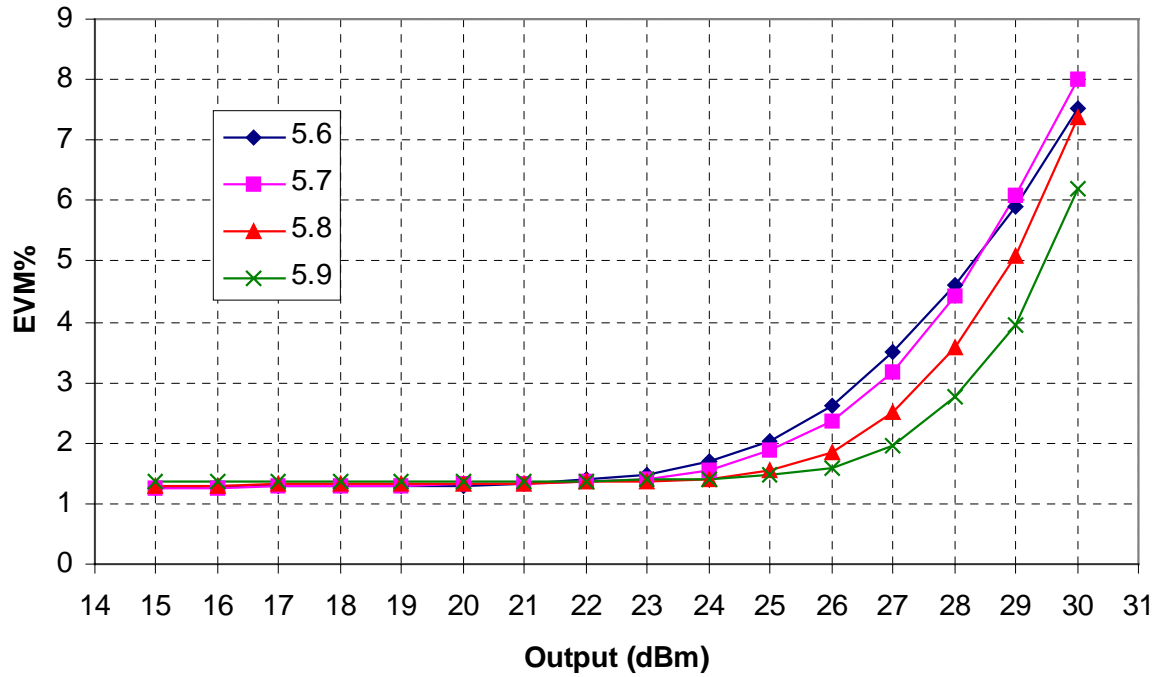

**S-Parameter Data**

**TGA2921-EPU-SG**

**Bias Conditions: Vd = 8V, Idq = 800 mA**

Frequency GHz	S11		S21		S12		S22	
	Mag (dB)	Deg	Mag (dB)	Deg	Mag (dB)	Deg	Mag (dB)	Deg
2	-0.922	149.46	4.656	24.256	-29.3	-37.522	-3.505	150.7
2.2	-0.981	143.96	3.92	16.783	-29.209	-42.194	-3.475	147.28
2.4	-1.05	138.28	3.307	9.155	-29.406	-47.499	-3.418	143.98
2.6	-1.036	132.61	2.795	1.767	-29.243	-53.754	-3.339	140.6
2.8	-1.03	126.31	2.386	-5.879	-29.775	-57.493	-3.311	137.76
3	-1.106	119.81	2.016	-13.755	-29.396	-61.715	-3.271	134.27
3.2	-1.098	113.17	1.728	-21.748	-29.382	-66.942	-3.201	131.09
3.4	-1.158	106	1.449	-29.653	-28.846	-68.808	-3.296	128.07
3.6	-1.199	99.251	1.243	-37.913	-29.221	-75.622	-3.28	125.27
3.8	-1.197	91.493	1.095	-46.321	-28.642	-80.881	-3.367	121.37
4	-1.227	83.195	1.01	-55.325	-28.672	-86.873	-3.489	118.05
4.2	-1.264	75.815	0.951	-64.172	-28.853	-88.318	-3.638	114.71
4.4	-1.243	67.974	0.965	-73.477	-28.391	-94.42	-3.798	111.03
4.6	-1.316	60.333	1.001	-82.808	-28.139	-99.236	-3.988	106.7
4.8	-1.289	53.55	1.067	-92.017	-28.186	-107.82	-4.162	102.8
5	-1.294	46.85	1.281	-102.18	-27.341	-112.38	-4.502	97.583
5.2	-1.386	40.476	1.557	-112.99	-26.85	-117.15	-4.839	93.32
5.4	-1.525	35.141	2.047	-124.38	-25.843	-122.68	-5.124	90.569
5.6	-1.722	30.104	2.69	-137.43	-25.035	-129.03	-5.22	87.491
5.8	-2.236	25.326	3.567	-152.77	-24.04	-140.21	-4.99	85.128
6	-3.267	20.912	4.543	-172.21	-22.9	-152.51	-4.534	81.826
6.2	-5.727	20.622	5.836	161.48	-21.466	-171.62	-3.592	76.362
6.4	-8.146	54.06	6.174	121.79	-20.988	155.54	-3.108	62.283
6.6	-3.358	70.677	3.551	76.907	-23.371	115.14	-5.439	54.397
6.8	-1.106	62.277	-1.382	42.823	-27.734	90.23	-6.671	72.529
7	-0.517	55.836	-7.259	20.341	-33.708	71.447	-4.576	84.699
7.2	-0.449	51.619	-14.016	11.985	-39.475	67.146	-2.75	86.182
7.4	-0.855	48.505	-18.186	50.179	-42.265	15.613	-1.661	85.135
7.6	-1.164	57.94	-13.962	6.444	-36.502	-86.187	-0.821	84.391
7.8	-0.463	56.854	-21.186	-27.207	-38.617	-127.41	-0.482	83.611
8	-0.351	57.361	-29.004	-44.161	-38.272	-104.42	-0.436	83.279
8.2	-0.301	59.013	-36.991	-63.144	-29.615	-137.1	-0.986	89.948
8.4	-0.324	62.41	-39.741	-104.49	-31.885	-159.36	-0.308	92.761
8.6	-0.231	67.099	-36.528	-157.52	-31.506	-162.78	-0.12	94.847
8.8	-0.16	72.616	-34.932	-167.76	-31.247	-163.91	-0.054	96.36
9	-0.061	78.923	-30.382	-177.25	-30.393	-165.96	-0.043	96.806

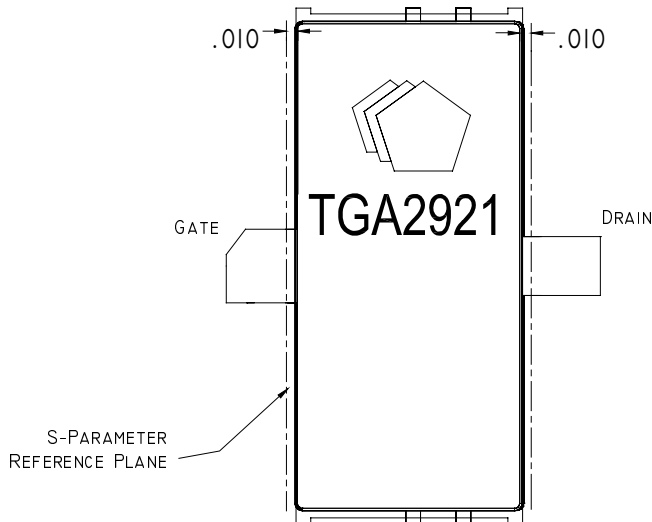



**Packaged Dimensional Drawing TGA2921-EPU - SG**

Top View

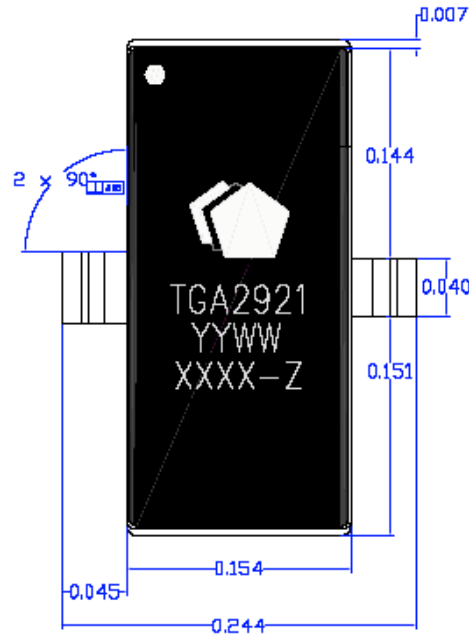

Side View

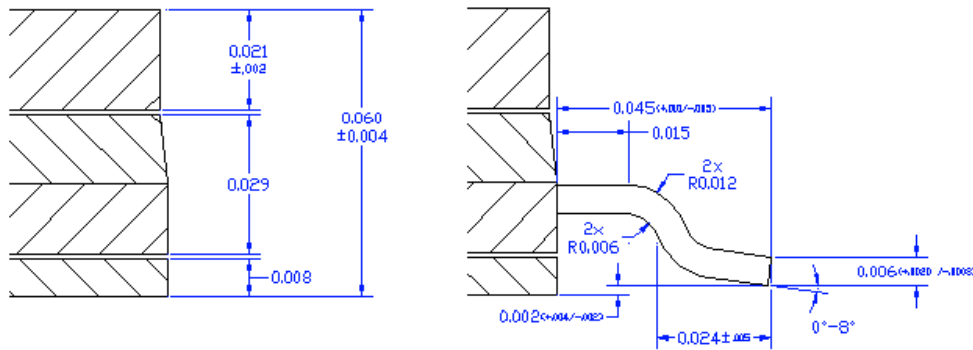

**Bias Procedure**

1. Ensure no RF power is applied to the device.
2. Pinch off device by setting  $V_g$  to  $-3V$ .
3. Increase  $V_d$  to 8.0V while monitoring drain current.
4. Increase  $V_g$  until drain current reaches 800 mA.
5. Apply RF power.

***GaAs MMIC devices are susceptible to damage from Electrostatic Discharge. Proper precautions should be observed during handling, assembly and test.***

### 5.8 GHz Application Circuit Schematic

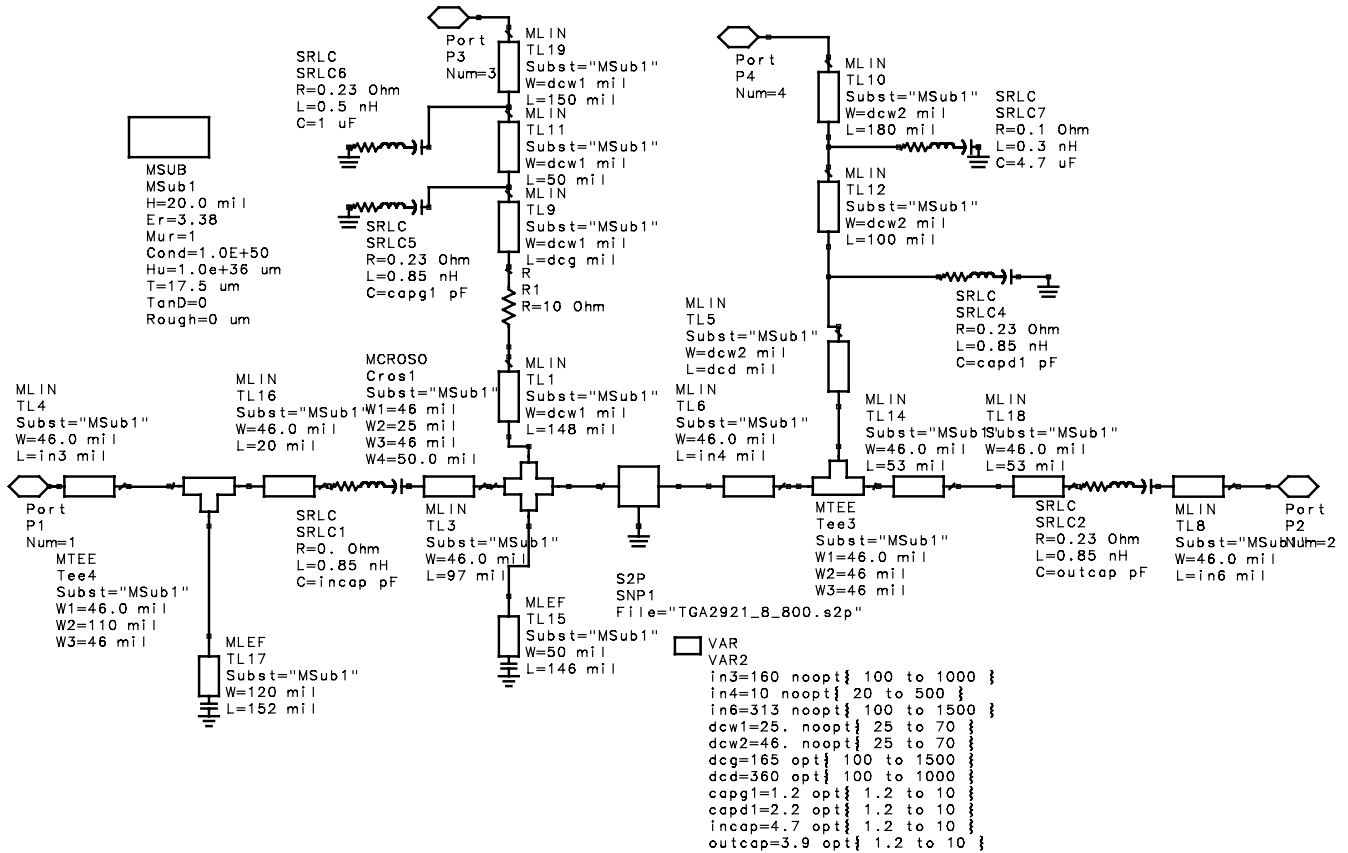

PCB is 20 mil thick Rogers 4003 substrate. The schematic is for small signal approach only

**Typical Evaluation Board Layout \***

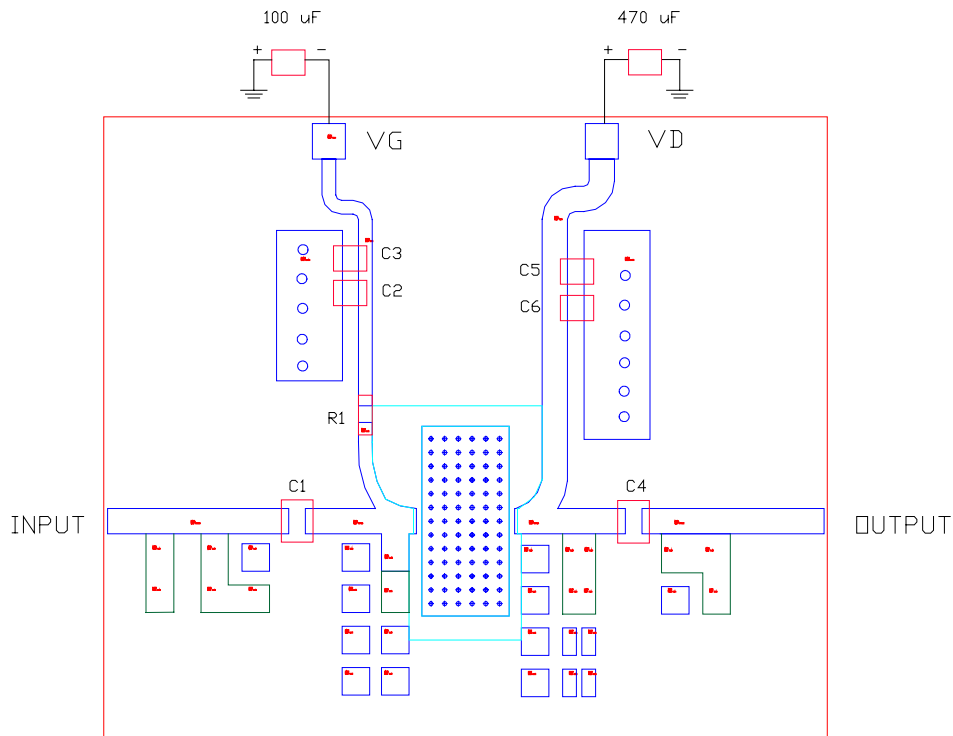

\*The layout is a general purpose drawing that needs to be tuned for the specific application. PCB is RO4003 20 mil thickness, 0.5 oz standard copper cladding, with  $E_r = 3.38$ .

**External Component Listing**

Part Type	Reference	Description
Capacitor	C1	AVX06035J4R7BBT, 4.7 pF
Capacitor	C2	AVX06035J1R2BBT, 1.2 pF
Capacitor	C3	1uF
Capacitor	C4	AVX06035J3R9BBT, 3.9 pF
Capacitor	C5	4.7 uF
Capacitor	C6	AVX06035J1R2BBT, 1.2 pF
Resistor	R1	0805, 10 $\Omega$

**Contact TriQuint Applications Engineering for additional info**

## Recommended Surface Mount Package Assembly

Proper ESD precautions must be followed while handling packages.

Clean the board with acetone. Rinse with alcohol. Allow the circuit to fully dry.

TriQuint recommends using a conductive solder paste for attachment. Follow solder paste and reflow oven vendors' recommendations when developing a solder reflow profile. Typical solder reflow profiles are listed in the table below.

Hand soldering is not recommended. Solder paste can be applied using a stencil printer or dot placement. The volume of solder paste depends on PCB and component layout and should be well controlled to ensure consistent mechanical and electrical performance.

Clean the assembly with alcohol.

## Typical Solder Reflow Profiles

Reflow Profile	SnPb	Pb Free
Ramp-up Rate	3 °C/sec	3 °C/sec
Activation Time and Temperature	60 – 120 sec @ 140 – 160 °C	60 – 180 sec @ 150 – 200 °C
Time above Melting Point	60 – 150 sec	60 – 150 sec
Max Peak Temperature	240 °C	260 °C
Time within 5 °C of Peak Temperature	10 – 20 sec	10 – 20 sec
Ramp-down Rate	4 – 6 °C/sec	4 – 6 °C/sec

## Ordering Information

Part	Package Style
TGA2921-SG	SMT Gull Wing (Formed Leads)