

## Applications

- Test Instrumentation
- Electronic Warfare (EW)
- Radar
- Communications

## Product Features

- Frequency Range: 6 – 18GHz
- P<sub>OUT</sub>: >43dBm @ P<sub>IN</sub> = 23dBm
- PAE: >20% @ P<sub>IN</sub> = 23dBm
- Large Signal Gain: >20dB @ P<sub>IN</sub> = 23dBm
- Small Signal Gain: >26dB
- Return Loss: >6.5dB
- Bias: V<sub>D</sub> = 20V, I<sub>DQ</sub> = 2500mA, V<sub>G</sub> = -2.3V Typical
- Chip Dimensions: 5.4 x 6.85 x 0.10 mm

## Functional Block Diagram

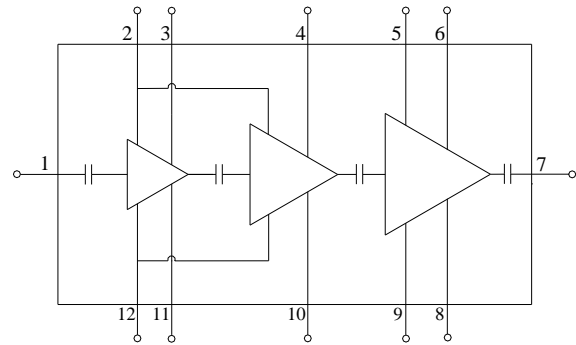

## General Description

Qorvo's TGA2963 is a broadband high power MMIC amplifier fabricated on Qorvo's production 0.15um GaN on SiC process (QGAN15). The TGA2963 operates from 6 – 18GHz and provides more than 20W saturated output power with power-added efficiency >20% and large-signal gain >20 dB. This combination of wideband performance provides the flexibility designers are looking for to improve system performance while reducing size and cost.

The TGA2963 is matched to 50Ω with integrated DC blocking capacitors on both RF I/O ports simplifying system integration. The broadband performance makes it ideally suited in support of test instrumentation and electronic warfare, as well as, supporting multiple radar and communication bands.

The TGA2963 is 100% DC and RF tested on-wafer to ensure compliance to electrical specifications.

Lead-free and RoHS compliant.

Evaluation boards are available upon request.

## Pad Configuration

Pad No.	Symbol
1	RF In
2, 12	V <sub>G12</sub>
3, 11	V <sub>D1</sub>
4, 10	V <sub>D2</sub>
5, 9	V <sub>G3</sub>
6, 8	V <sub>D3</sub>
7	RF Out

## Ordering Information

Part	ECCN	Description
TGA2963	3A001.b.2.c	6 – 18GHz 20W GaN Power Amplifier

### Absolute Maximum Ratings

Parameter	Value
Drain Voltage ( $V_D$ )	29.5V
Gate Voltage Range ( $V_G$ )	-8 to 0V
Drain Current ( $I_{D1}$ )	960mA
Drain Current ( $I_{D2}$ )	1440mA
Drain Current ( $I_{D3}$ )	5760mA
Gate Currents ( $I_{G1}/I_{G2}/I_{G3}$ )	See plot on page 3
Power Dissipation ( $P_{DISS}$ ), 85°C, CW	150W
Input Power ( $P_{IN}$ ), 50Ω, $V_D = 20V$ , $I_{DQ} = 2500$ mA, 85°C, CW	30dBm
Input Power ( $P_{IN}$ ), VSWR 3:1, $V_D = 20V$ , $I_{DQ} = 2500$ mA, 85°C, CW	30dBm
Channel Temperature ( $T_{CH}$ )	275°C
Mounting Temperature (30 seconds)	320°C
Storage Temperature	-55 to 150°C

Operation of this device outside the parameter ranges given above may cause permanent damage. These are stress ratings only, and functional operation of the device at these conditions is not implied.

### Recommended Operating Conditions

Parameter	Value
Drain Voltage ( $V_D$ )	20V
Drain Current ( $I_{DQ}$ )	2500mA (Total)
Gate Voltage ( $V_G$ )	-2.3V (Typ.)

Electrical specifications are measured at specified test conditions. Specifications are not guaranteed over all recommended operating conditions.

### Electrical Specifications

Test conditions unless otherwise noted: 25°C,  $V_D = 20V$ ,  $I_{DQ} = 2500mA$ ,  $V_G = -2.3V$  Typical

Parameter	Min	Typical	Max	Units
Operational Frequency Range	6		18	GHz
Small Signal Gain		>26		dB
Input Return Loss		>8		dB
Output Return Loss		>6.5		dB
Power Gain ( $P_{in} = 23dBm$ )		>20		dB
Output Power ( $P_{in} = 23dBm$ )		>43		dBm
Power Added Efficiency ( $P_{in} = 23dBm$ )		>20		%
Small Signal Gain Temperature Coefficient		-0.062		dB/°C
Output Power Temperature Coefficient		-0.017		dBm/°C

**Thermal and Reliability Information**

Parameter	Test Conditions	Value	Units
Thermal Resistance ( $\theta_{JC}$ ) <sup>(1)</sup>	$T_{base} = 85^{\circ}C$ , CW	1.26	$^{\circ}C/W$
Channel Temperature ( $T_{CH}$ ) (No RF drive)	$V_D = 20V$ , $I_{DQ} = 2500mA$	148	$^{\circ}C$
Median Lifetime ( $T_M$ )	$P_{DISS} = 50W$	$1.1 \times 10^{10}$	Hrs
Thermal Resistance ( $\theta_{JC}$ ) <sup>(1)</sup>	$T_{base} = 85^{\circ}C$ , $V_D = 20V$ , $I_{DQ} = 2500mA$ , CW	1.56	$^{\circ}C/W$
Channel Temperature ( $T_{CH}$ ) (Under RF drive)	$I_{D Drive} = 6.6A$ , Freq = 12GHz	250	$^{\circ}C$
Median Lifetime ( $T_M$ )	$P_{IN} = 25dBm$ , $P_{OUT} = 45dBm$ , $P_{DISS} = 106W$	$1.1 \times 10^6$	Hrs

Notes:

1. Thermal resistance measured to back of carrier plate. MMIC mounted on 40 mils CuMo (80/20) carrier using 3 mil AuSn.

Test Conditions:  $V_D = 28V$ ; Failure Criteria = 10% reduction in  $I_{D\_MAX}$

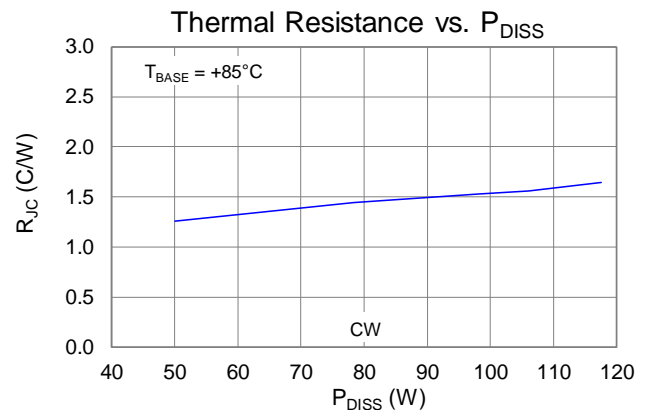
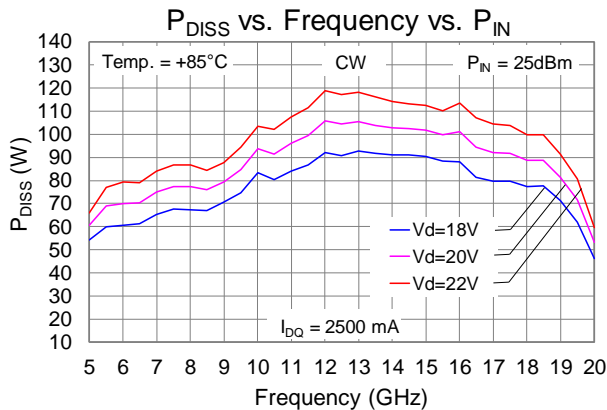
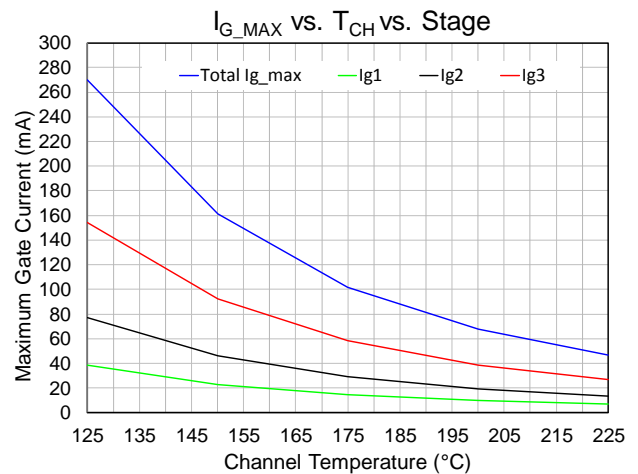
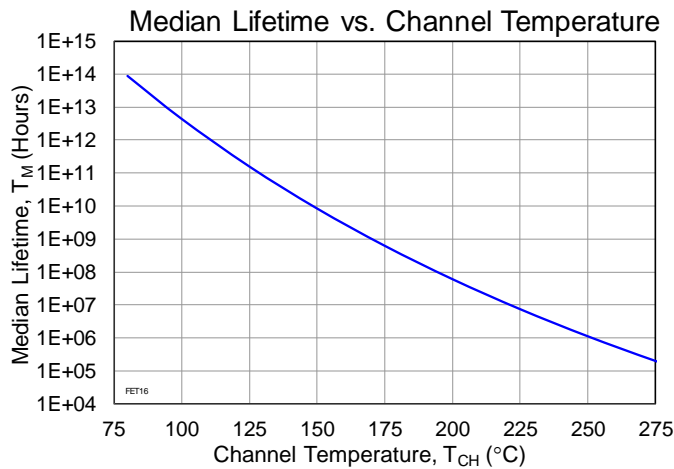

**Typical Performance (Small Signal)**

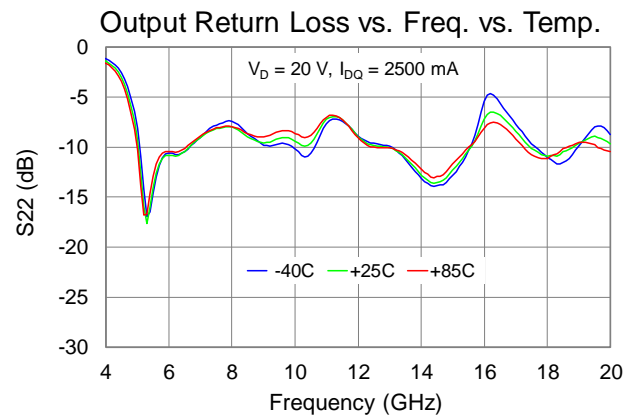
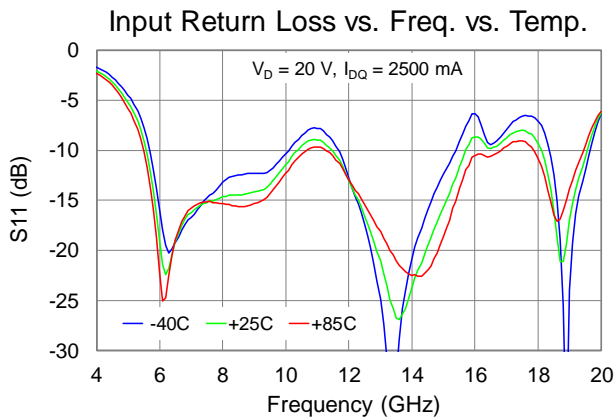
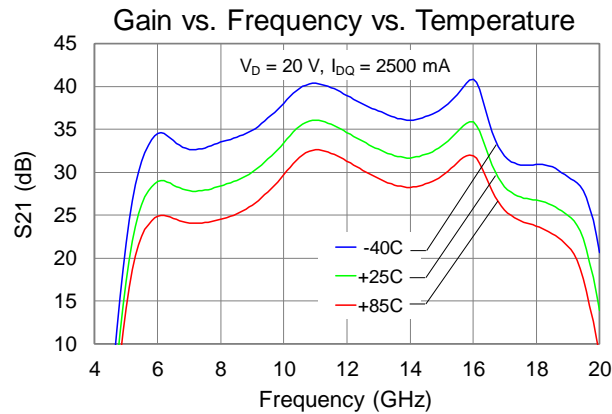
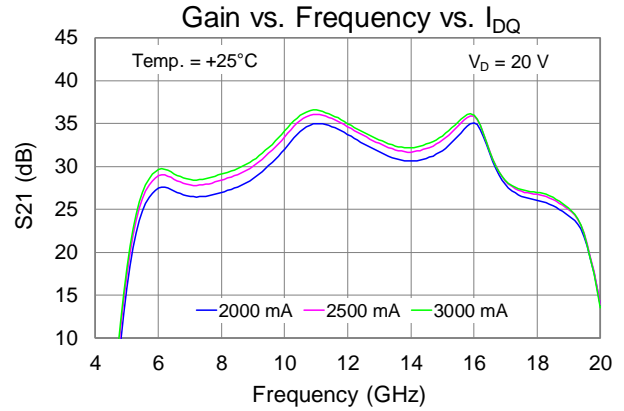
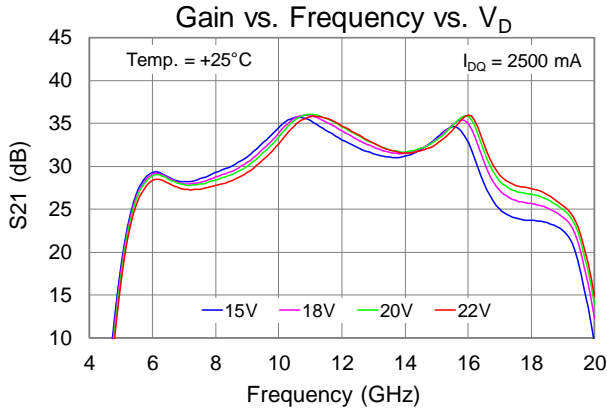

Typical Performance (Large Signal CW)

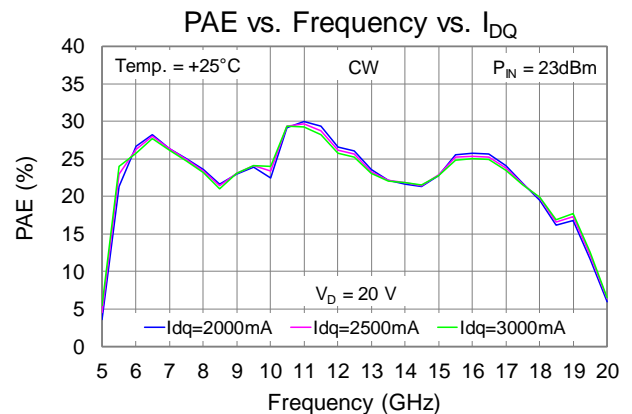
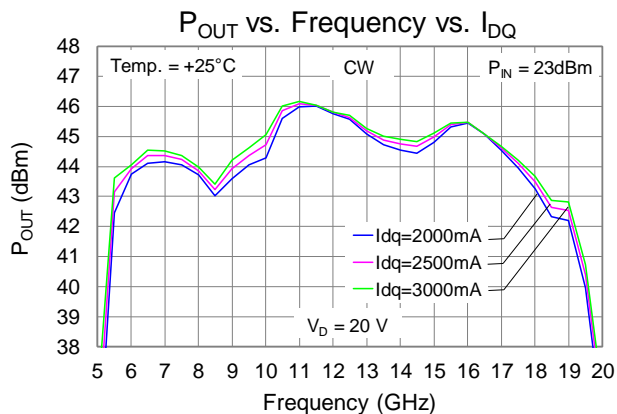
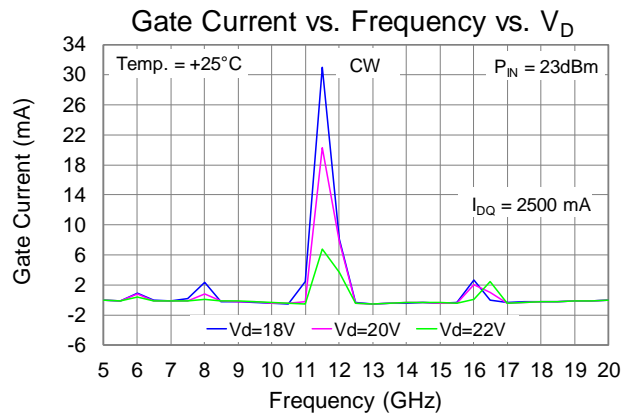
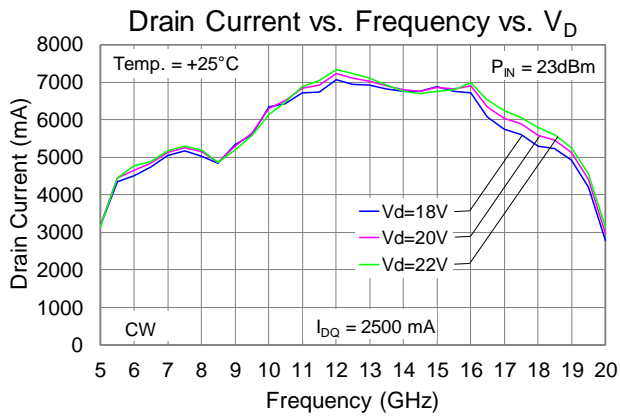
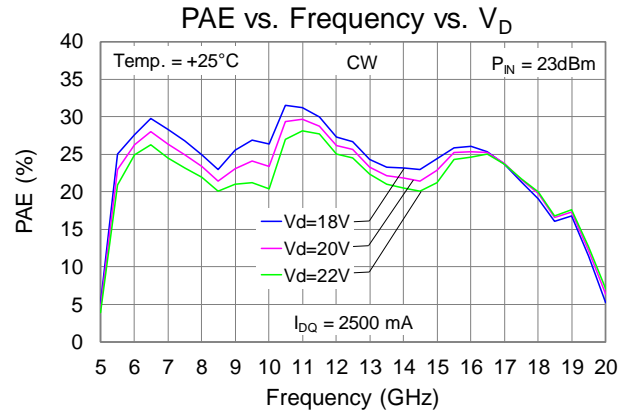
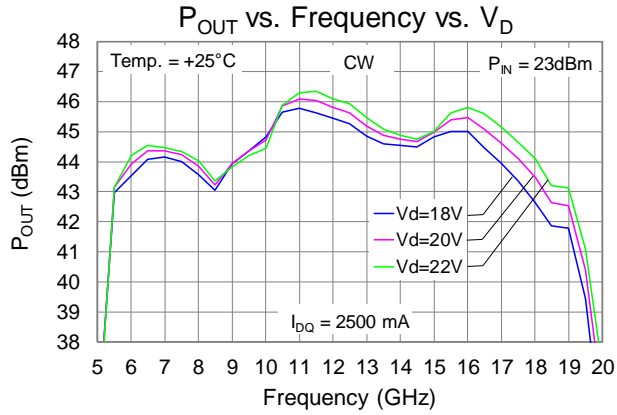

Typical Performance (Large Signal CW)

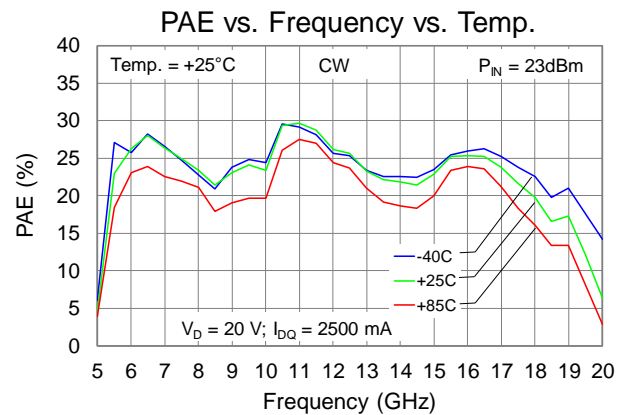
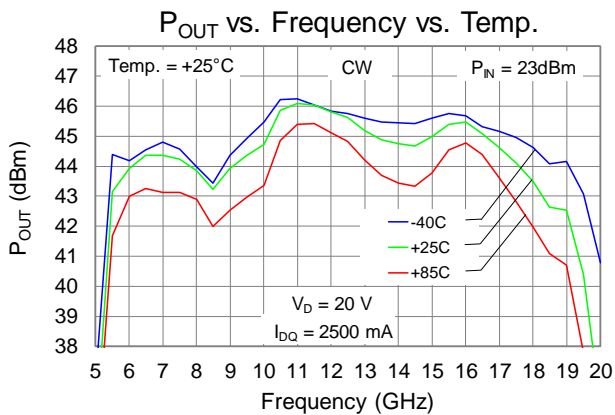
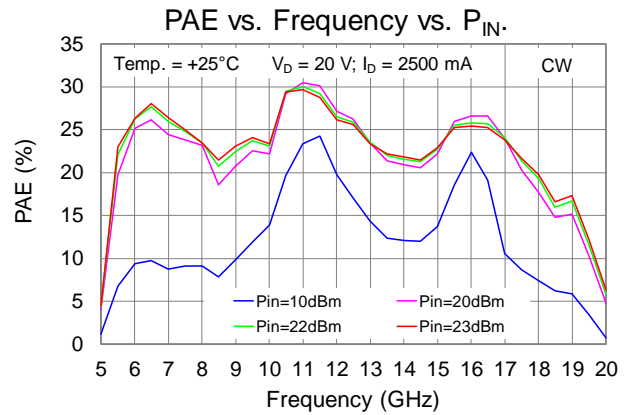
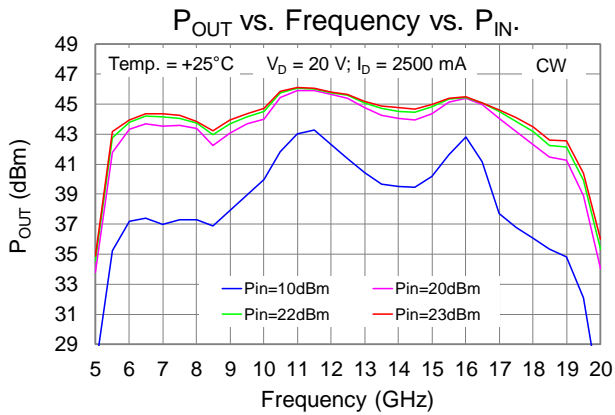
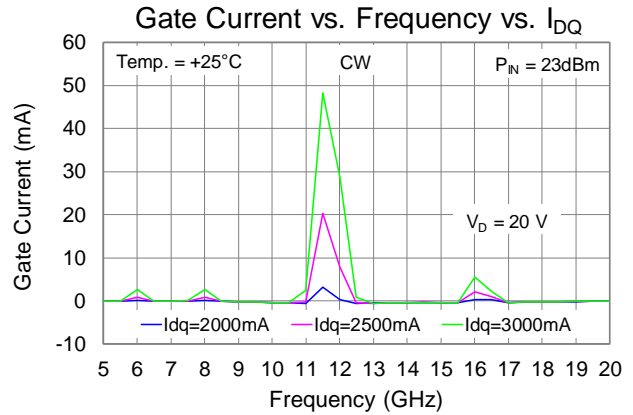
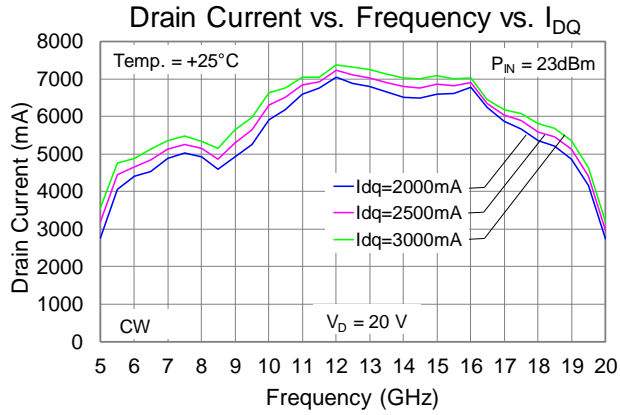

Typical Performance (Large Signal CW)

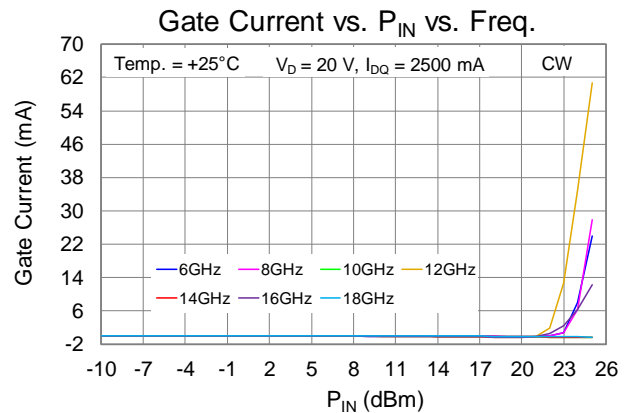
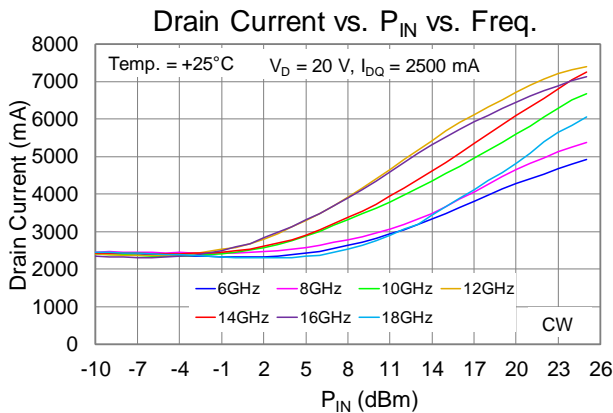
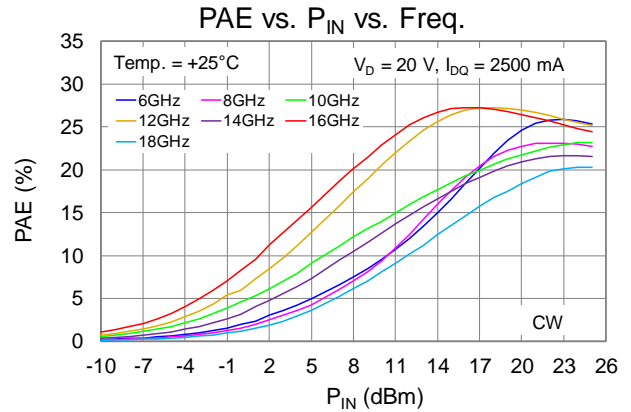
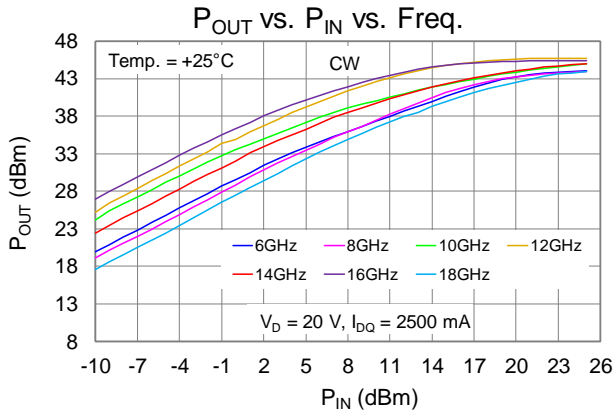
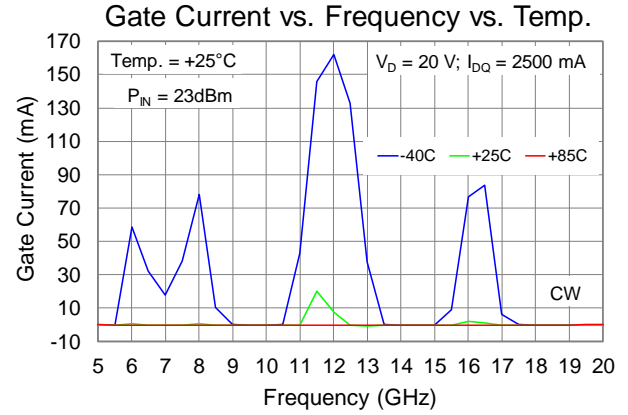
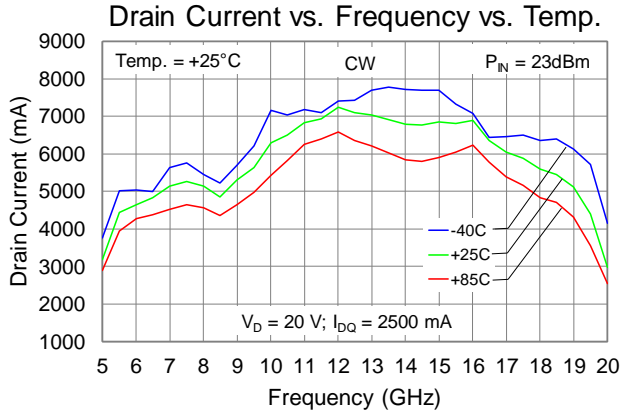

Typical Performance (Large Signal & Linearity)

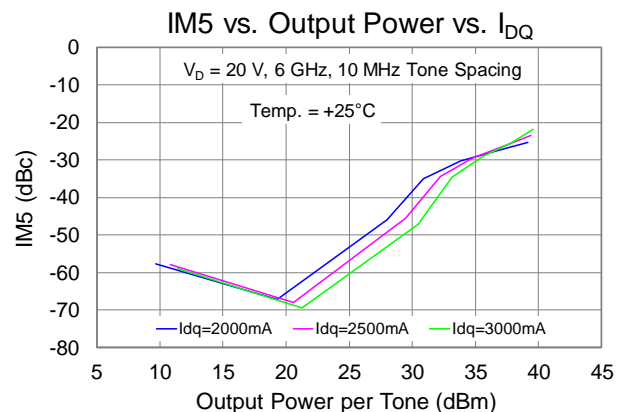
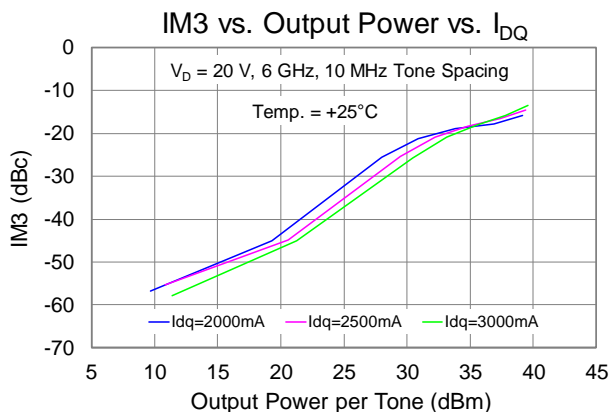
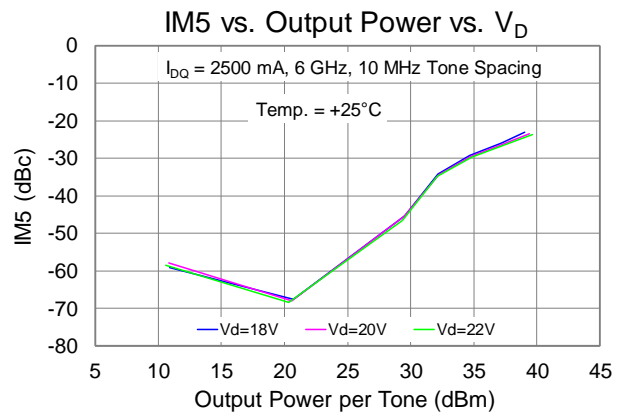
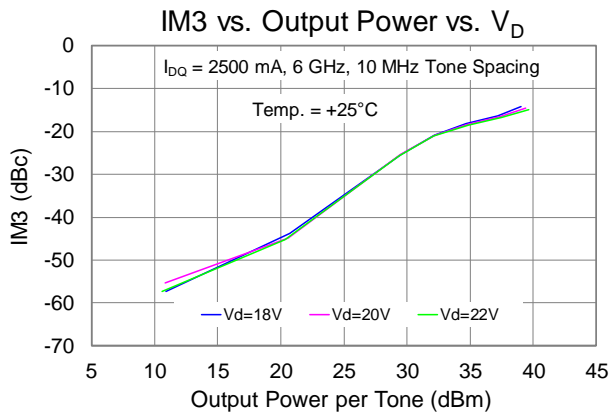
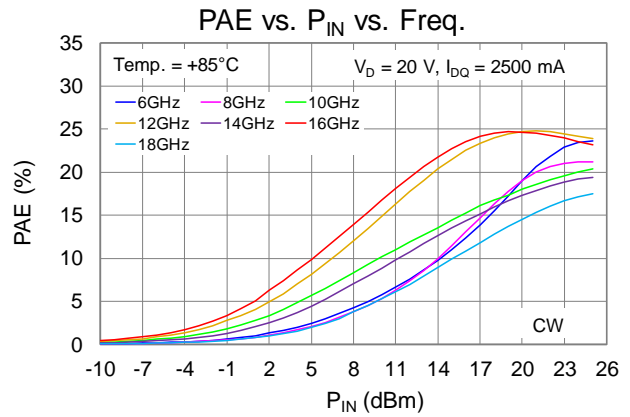
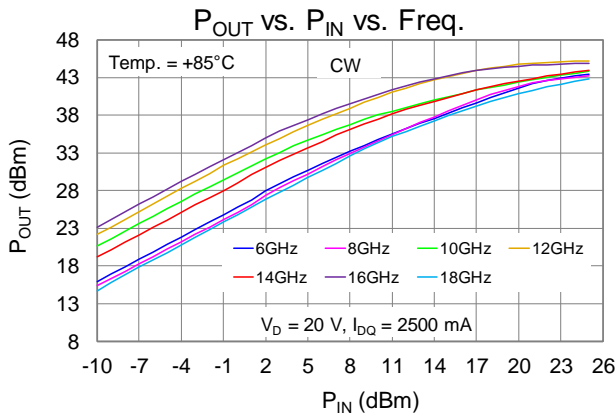



**Typical Performance (Linearity)**

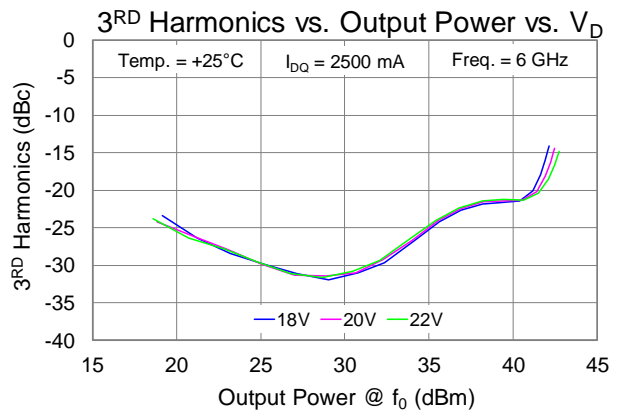
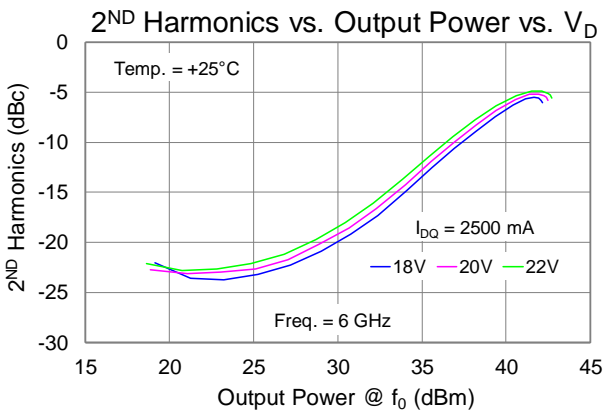
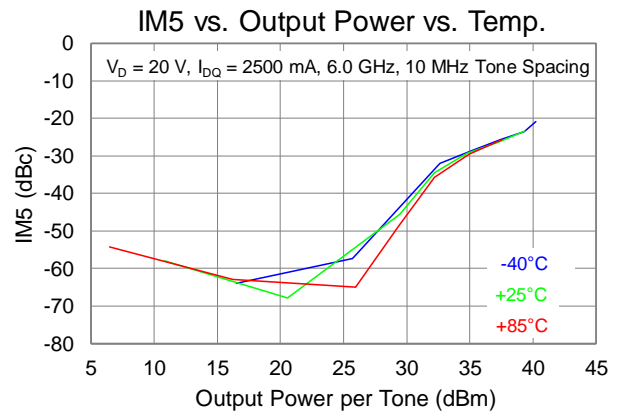
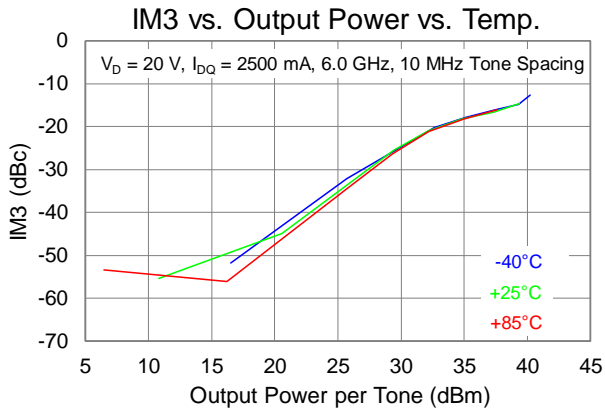
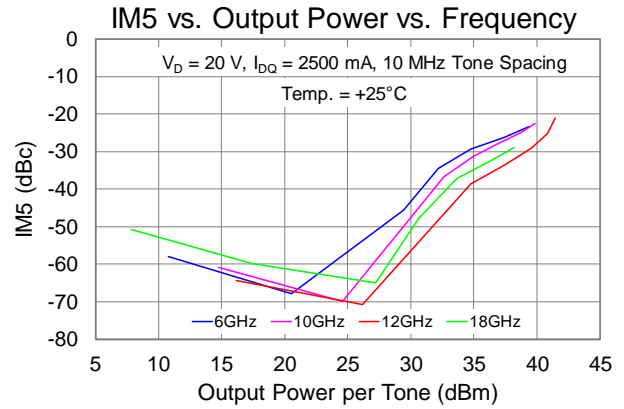
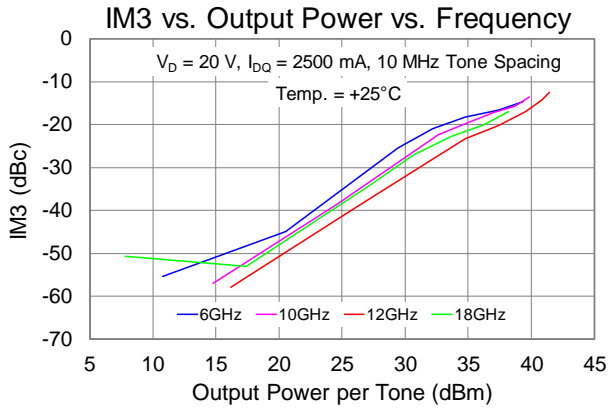

Typical Performance (Linearity)

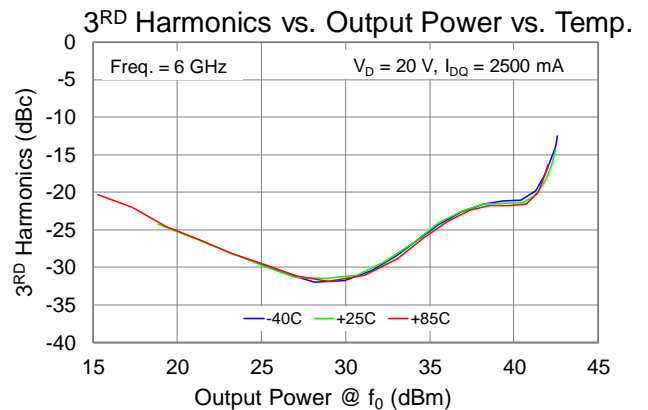
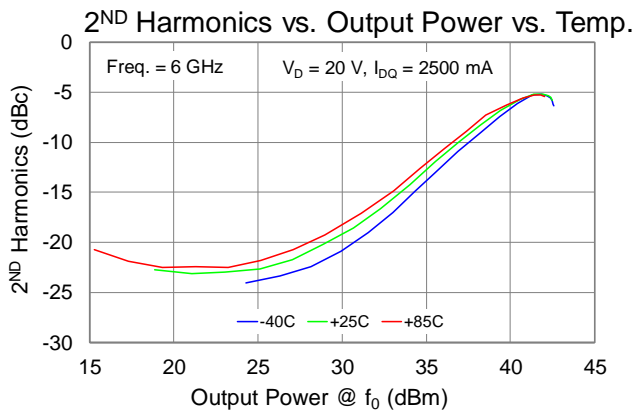
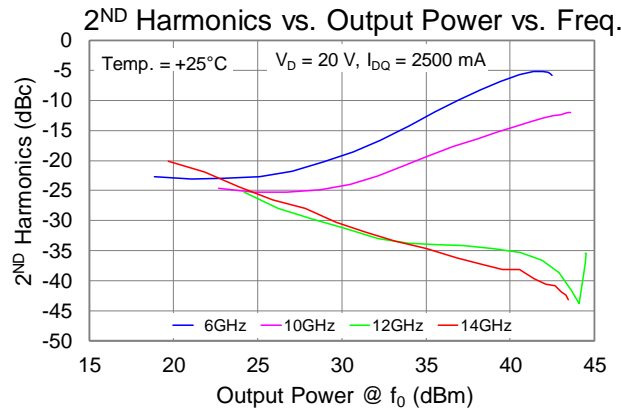
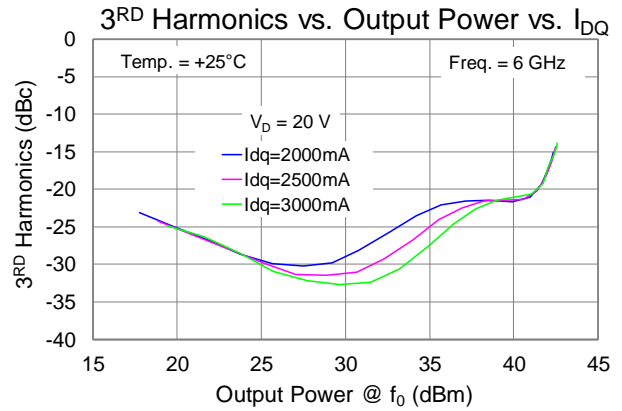
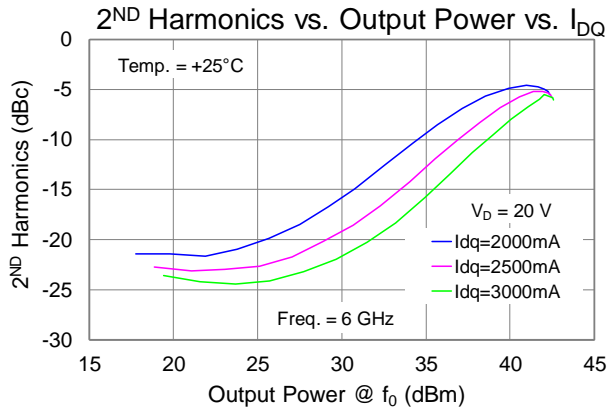

## Application Circuit

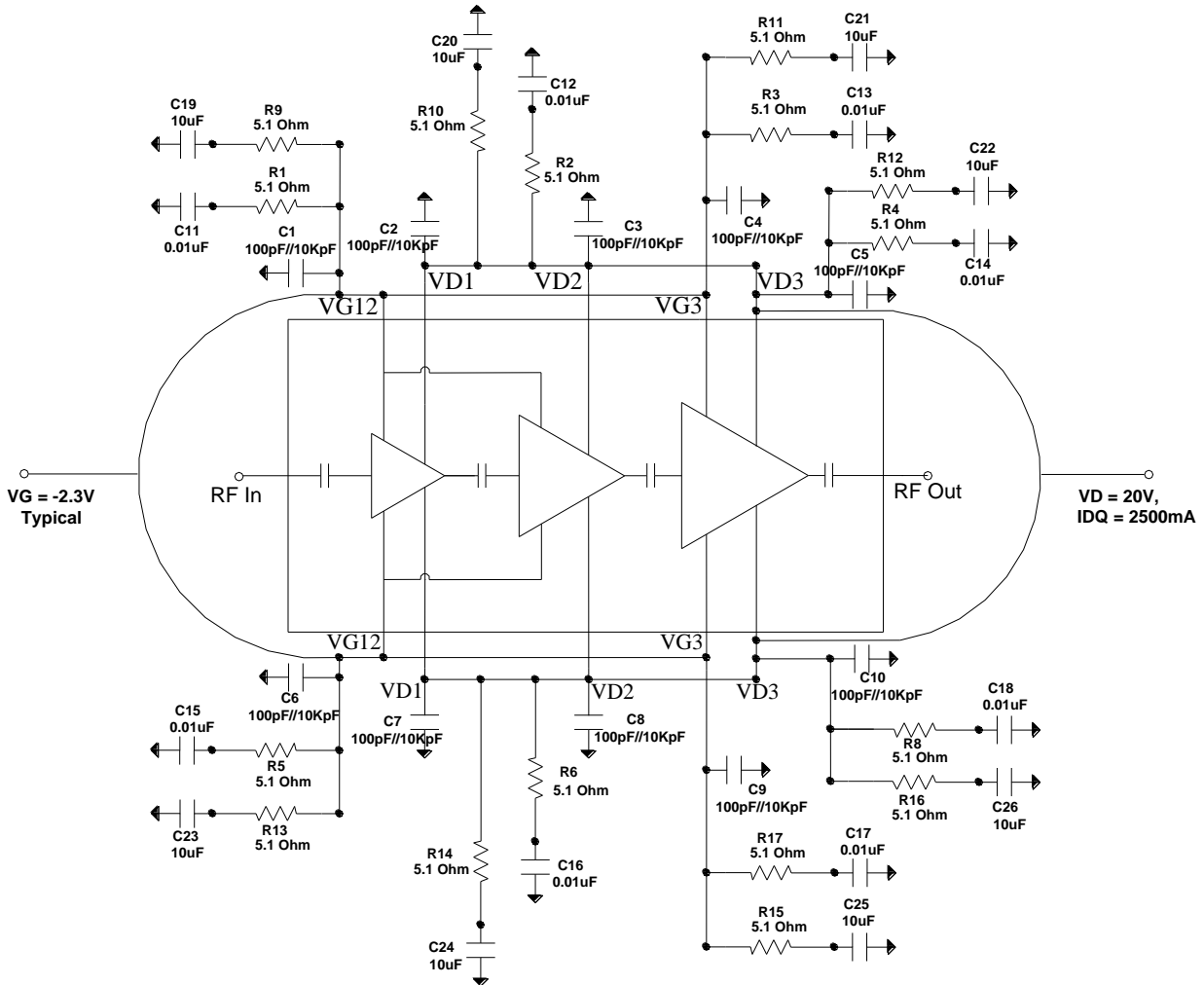

### Bias-up Procedure

1. Set  $I_D$  limit to 8A,  $I_G$  limit to 50mA
2. Set  $V_G$  to -5.0V
3. Set  $V_D$  +20V
4. Adjust  $V_G$  more positive until  $I_{DQ} = 2500mA$  ( $V_G \sim -2.3V$  Typical)
5. Apply RF signal

### Bias-down Procedure

1. Turn off RF signal
2. Reduce  $V_G$  to -5.0V. Ensure  $I_{DQ} \sim 0mA$
3. Set  $V_D$  to 0V
4. Turn off  $V_D$  supply
5. Turn off  $V_G$  supply

**Evaluation Board (EVB) Layout Assembly**

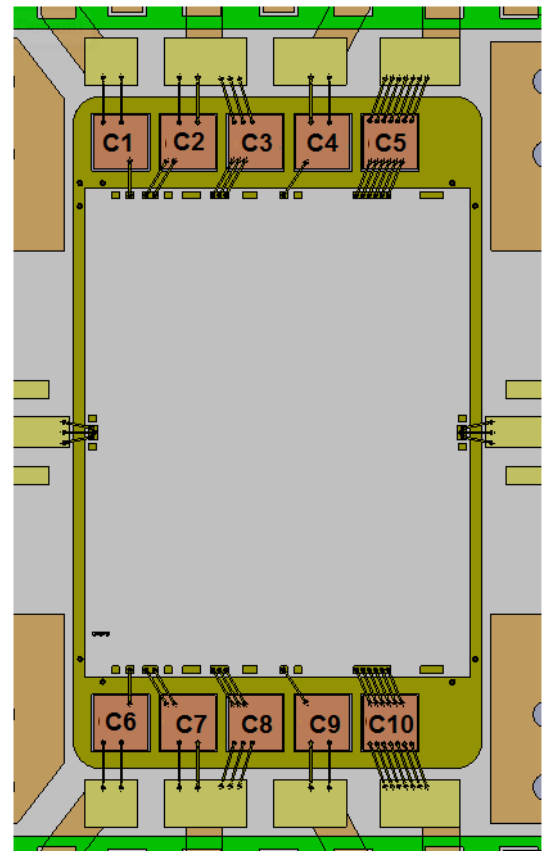
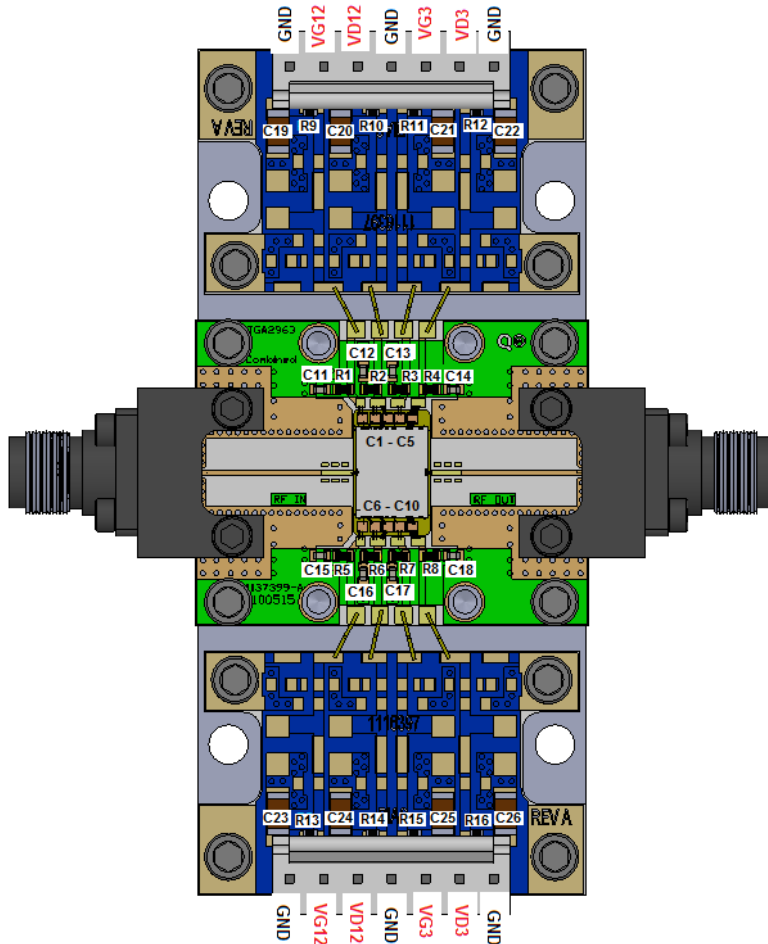

MMIC mounting/wire bonding detail

Notes: The MMIC must be biased from both sides top and bottom.

**Bill of Materials**

Reference Design	Value	Description	Manufacturer	Part Number
C1 – C10	100pF//10KpF	Cap, 30x30, 50V, Single Layer	Various	
C11 – C18	0.01uF	Cap, 0402, 50V, 10%, X7R	Various	
C19 – C26	10uF	Cap, 1206, 50V, 20%, X5R	Various	
R1 – R16	5.1Ω	Res, 0402, 50V, 5%, SMT	Various	

**Mechanical Drawing & Bond Pad Description**

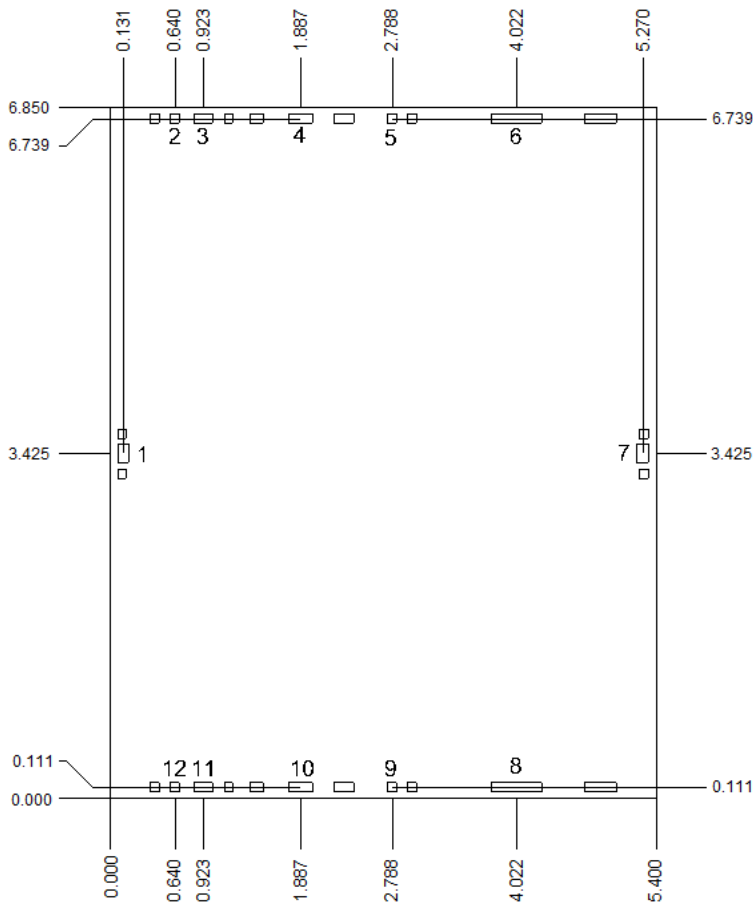

Unit: millimeters  
 Thickness: 0.10  
 Die x, y size tolerance: +/- 0.050  
 Chip edge to bond pad dimensions are shown to center of pad  
 Ground is backside of die

Bond Pad Symbol	Pad Size	Description
1	RF In	0.115 x 0.190 RF Input; matched to 50Ω; DC blocked
2, 12	VG12	0.090 x 0.090 Gate voltage 1-2, bias network is required; see Application Circuit on page 11 as an example.
3, 11	VD1	0.190 x 0.090 Drain voltage 1, bias network is required; see Application Circuit on page 11 as an example
4, 10	VD2	0.235 x 0.090 Drain voltage 2, bias network is required; see Application Circuit on page 11 as an example.
5, 9	VG3	0.090 x 0.090 Gate voltage 3, bias network is required; see Application Circuit on page 11 as an example.
6, 8	VD3	0.508 x 0.090 Drain voltage 3, bias network is required; see Application Circuit on page 11 as an example.
7	RF Out	0.115 x 0.190 RF Output; matched to 50Ω; DC blocked

## Assembly Notes

Component placement and adhesive attachment assembly notes:

- Vacuum pencils and/or vacuum collets are the preferred method of pick up.
- Air bridges must be avoided during placement.
- The force impact is critical during auto placement.
- Organic attachment (i.e. epoxy) can be used in low-power applications.
- Curing should be done in a convection oven; proper exhaust is a safety concern.

Reflow process assembly notes:

- Use AuSn (80/20) solder and limit exposure to temperatures above 300°C to 3-4 minutes, maximum.
- An alloy station or conveyor furnace with reducing atmosphere should be used.
- Do not use any kind of flux.
- Coefficient of thermal expansion matching is critical for long-term reliability.
- Devices must be stored in a dry nitrogen atmosphere.

Interconnect process assembly notes:

- Thermosonic ball bonding is the preferred interconnect technique.
- Force, time, and ultrasonic are critical parameters.
- Aluminum wire should not be used.
- Devices with small pad sizes should be bonded with 0.0007-inch wire.

**Product Compliance Information**

**ESD Sensitivity Ratings**



Caution! ESD-Sensitive Device

ESD Rating: TBD  
 Value: TBD  
 Test: Human Body Model (HBM)  
 Standard: JEDEC Standard JESD22-A114

**ECCN**

US Department of Commerce: 3A001.b.2.c

**Solderability**

Use AuSn (80/20) solder and limit exposure to temperatures above 300°C to 3-4 minutes, maximum.

**RoHS Compliance**

This part is compliant with EU 2002/95/EC RoHS directive (Restrictions on the Use of Certain Hazardous Substances in Electrical and Electronic Equipment).

This product also has the following attributes:

- Lead Free
- Halogen Free (Chlorine, Bromine)
- Antimony Free
- TBBP-A (C<sub>15</sub>H<sub>12</sub>Br<sub>4</sub>O<sub>2</sub>) Free
- PFOS Free
- SVHC Free

**Contact Information**

For the latest specifications, additional product information, worldwide sales and distribution locations, and information about TriQuint:

**Web:** [www.triquint.com](http://www.triquint.com)      **Tel:** +1.972.994.8465  
**Email:** [info-sales@triquint.com](mailto:info-sales@triquint.com)      **Fax:** +1.972.994.8504

For technical questions and application information:      **Email:** [info-products@triquint.com](mailto:info-products@triquint.com)

**Important Notice**

The information contained herein is believed to be reliable. TriQuint makes no warranties regarding the information contained herein. TriQuint assumes no responsibility or liability whatsoever for any of the information contained herein. TriQuint assumes no responsibility or liability whatsoever for the use of the information contained herein. The information contained herein is provided "AS IS, WHERE IS" and with all faults, and the entire risk associated with such information is entirely with the user. All information contained herein is subject to change without notice. Customers should obtain and verify the latest relevant information before placing orders for TriQuint products. The information contained herein or any use of such information does not grant, explicitly or implicitly, to any party any patent rights, licenses, or any other intellectual property rights, whether with regard to such information itself or anything described by such information.

TriQuint products are not warranted or authorized for use as critical components in medical, life-saving, or life-sustaining applications, or other applications where a failure would reasonably be expected to cause severe personal injury or death.